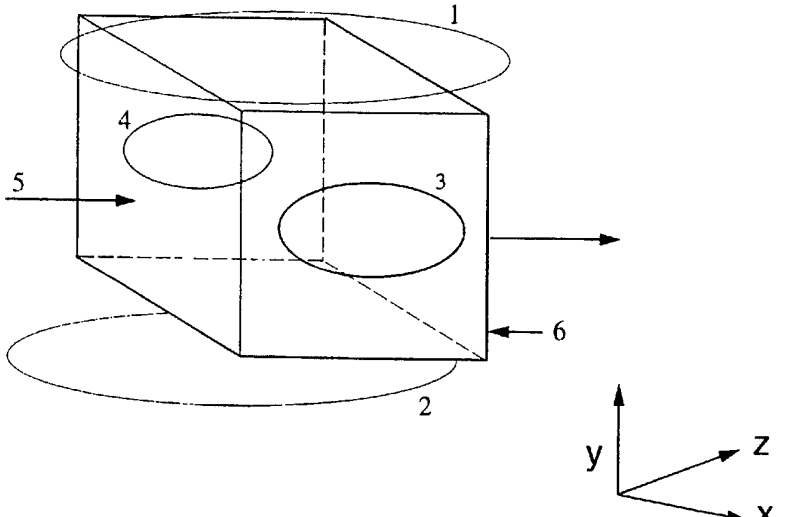

INTERNATIONAL APPLICATION PUBLISHED UNDER THE PATENT COOPERATION TREATY (PCT)

<p>(51) International Patent Classification ⁶ : G01S 13/78, G08B 13/24, G01V 3/10, H01Q 7/00</p>	<p>A1</p>	<p>(11) International Publication Number: WO 95/14938</p> <p>(43) International Publication Date: 1 June 1995 (01.06.95)</p>
<p>(21) International Application Number: PCT/AU94/00731</p> <p>(22) International Filing Date: 25 November 1994 (25.11.94)</p> <p>(30) Priority Data: PM 2676 26 November 1993 (26.11.93) AU</p> <p>(71) Applicant (for all designated States except US): MAGELLAN TECHNOLOGY PTY. LTD. [AU/AU]; 17 Vulcan Road, Canningvale, W.A. 6155 (AU).</p> <p>(72) Inventors; and (75) Inventors/Applicants (for US only): MURDOCH, Graham, Alexander, Munro [GB/AU]; 17 Vulcan Road, Canningvale, W.A. 6155 (AU). LITTLECHILD, Stuart, Colin [AU/AU]; 17 Vulcan Road, Canningvale, W.A. 6155 (AU).</p> <p>(74) Agent: WATERMARK PATENT & TRADEMARK ATTORNEYS; 290 Burwood Road, Hawthorn, VIC 3122 (AU).</p>		<p>(81) Designated States: AM, AT, AU, BB, BG, BR, BY, CA, CH, CN, CZ, DE, DK, EE, ES, FI, GB, GE, HU, JP, KE, KG, KP, KR, KZ, LK, LR, LT, LU, LV, MD, MG, MN, MW, NL, NO, NZ, PL, PT, RO, RU, SD, SE, SI, SK, TJ, TT, UA, US, UZ, VN, European patent (AT, BE, CH, DE, DK, ES, FR, GB, GR, IE, IT, LU, MC, NL, PT, SE), OAPI patent (BF, BJ, CF, CG, CI, CM, GA, GN, ML, MR, NE, SN, TD, TG), ARIPO patent (KE, MW, SD, SZ).</p> <p>Published With international search report.</p>
<p>(54) Title: LOCATION APPARATUS AND METHOD</p>		
		
<p>(57) Abstract</p> <p>An apparatus to determine the identification, position and/or orientation of multiple devices within an interrogation zone (6). The apparatus equates the received signal to a point/region in the interrogation zone (6), based upon an attribute/component of the received signal. A method to determine the location, position, orientation and/or identification of at least one device within an interrogation zone (6). The method equates an attribute/component of the received signal to a point/region in the interrogation zone (6). Wherein the attribute/component could be field strength or signal power ratio. A "C" shaped interrogator coil (1, 2, 3, 4) formed from 2+"L" shaped coils. A multiple identification system that allocates a number of receiver channels for multiple identification and allocates 1+ other channels specifically for communication with 1+ devices. An interrogator having receiver coils (1, 2, 3, 4) wherein 1+ coils (1, 2, 3, 4) have a particular angular orientation to an axis. A specific application is multiple identification tag distinguishing in airline baggage handling/sorting.</p>		

FOR THE PURPOSES OF INFORMATION ONLY

Codes used to identify States party to the PCT on the front pages of pamphlets publishing international applications under the PCT.

AT	Austria	GB	United Kingdom	MR	Mauritania
AU	Australia	GE	Georgia	MW	Malawi
BB	Barbados	GN	Guinea	NE	Niger
BE	Belgium	GR	Greece	NL	Netherlands
BF	Burkina Faso	HU	Hungary	NO	Norway
BG	Bulgaria	IE	Ireland	NZ	New Zealand
BJ	Benin	IT	Italy	PL	Poland
BR	Brazil	JP	Japan	PT	Portugal
BY	Belarus	KE	Kenya	RO	Romania
CA	Canada	KG	Kyrgystan	RU	Russian Federation
CF	Central African Republic	KP	Democratic People's Republic of Korea	SD	Sudan
CG	Congo	KR	Republic of Korea	SE	Sweden
CH	Switzerland	KZ	Kazakhstan	SI	Slovenia
CI	Côte d'Ivoire	LI	Liechtenstein	SK	Slovakia
CM	Cameroon	LK	Sri Lanka	SN	Senegal
CN	China	LU	Luxembourg	TD	Chad
CS	Czechoslovakia	LV	Latvia	TG	Togo
CZ	Czech Republic	MC	Monaco	TJ	Tajikistan
DE	Germany	MD	Republic of Moldova	TT	Trinidad and Tobago
DK	Denmark	MG	Madagascar	UA	Ukraine
ES	Spain	ML	Mali	US	United States of America
FI	Finland	MN	Mongolia	UZ	Uzbekistan
FR	France			VN	Viet Nam
GA	Gabon				

LOCATION APPARATUS AND METHOD

Field of Invention

The present specification describes a number of inventive aspects related to an apparatus and/or method which provides positioning/location, orientation, identification information for and/or communication with tags within an interrogation area. The apparatus and/or method have an exemplary use in the sorting of airline baggage to which the tags are attached.

One aspect described relates to position and/or orientation determination and identification of one or more tags within an interrogation zone. Another aspect relates to the provision and design of an antenna or coils within the interrogator. Yet another aspect relates to a particular coil shape. A still further aspect deals with orientation determination.

The apparatus and method(s) have particular, but not exclusive, application to the technology of multiple identification.

15 Background Art

Prior art devices which are currently used to interrogate and communicate with tags are generally able to communicate with one tag at a time. Therefore, the prior art devices, for example those applicable to the sorting of baggage, are designed to pass one item of baggage (to which a tag is attached) at a time, necessitating a relatively large spacing between each item. This serves to further reduce the throughput, particularly for automated sorting purposes, where the particular destination of each item must be known.

Exemplifying the prior art is US 5,072,222 which discloses an electromagnetic identification and location system. The system utilises an additional position sensitive antenna arrangement, which provides positioning information based on a phase measurement of a pilot signal. It is not possible in this system to make a position determination in the case of two tags simultaneously emitting a pilot signal due to the interference of the two signals with each other.

30 US 4,663,625 also discloses an identification system. The system, however, is not adapted to identify or locate more than one tag at a time. If two of the tags enter the interrogating field together, each tag would emit its

identification signal, and the emissions and readings from the two tags would interfere with each other. The receiver would then receive the interfered readings and individual tag location or identification would not be possible.

US 5,274,392 discloses an antenna system in which a frame antenna is
5 disposed at an angle relative to two axes in order to reduce "dead-zones" in the interrogation area. This system is considered, however, to be relatively complex.

In other prior art arrangements, in the case of bulk recognition, if a number of tags are being communicated with, there is a need to gather
10 information which is unique to each device, such as the location and/or position within a known space of a tag being communicated with, interrogated and/or identified. The need is even more evident, where a number of tags, are being identified at the one time. A correlation must be established between the multiplicity of tags and their unique identification code or unique signal as
15 received by an interrogator.

Object of Invention

An object of the present invention is to provide a method and/or apparatus adapted to determine information, such as the position, of one or more tags within an interrogation area to be determined.

20 Summary of Invention

The present invention is based on the realization that measurement, comparison and/or analysis of attributes and/or components of a signal can provide a means of determining position/location, orientation and/or identification. Signal attributes or components of a signal such as field or signal
25 strength, ratio of field or signals, power levels or ratios, signal amplitude, voltage, or code sequence may be used within the scope of the present invention to provide a location, positioning, orientation and/or identification of an article within a given interrogation volume.

A signal received or reflected from the interrogated article or tag has
30 been found to provide a useful mechanism for obtaining signal attributes or components, such as field strength(s) at a particular point within a the interrogated area. Reference data known about the interrogation area, such as

a "field map", may be used to assist in determining the location, positioning, orientation, communication and/or identification of the article or tag. The determination can then be equated to a point or region in that interrogation volume that represents those signal attributes. The signal can also be used to
5 associate data received by an interrogator with a particular point in the interrogated volume. Determination of each point or region in one, two or three dimensional space serves to reflect position or orientation of each respective article being interrogated.

In particular, one aspect of the present invention is predicated on
10 association of data and/or the obtaining of information relating to location, position, orientation and/or identification of a signal source and its associated object(s) within a given volume based on determining signal attributes or components in one or more planes. In the case of two or more planes, the intersection of planes at a particular point can be determined from power ratio or
15 signal strength information.

The present invention provides a method and apparatus adapted to determine location, position, orientation and/or identify an article within a given volume, the apparatus or method having:

means for providing an irradiated field in at least one plane within the
20 given volume;

means for analysing a signal returned from the article;

the analysing means determining a predetermined attribute or component of the signal; and

means for equating the attribute or component to a location, position or
25 identification with the volume.

The present invention also provides an apparatus or method adapted to enable the association of data or information with a particular device being interrogated, the association being determined by a signal received from the device.

30 In one form, the present invention may provide a determination of position, location, and/or orientation of a tag within an interrogation volume based on a comparison of signals received from the tag against a "field-map"

corresponding to the interrogation volume.

Preferably, the measuring means measures field strength of the returned field in at least the two planes.

It is also preferable to measure, analyse or determine signal attributes or
5 components at each individual frequency, simultaneously or sequentially. In
this embodiment, the present invention provides an enhancement or additional
features to the present Applicant's "multiple identification" technology (for
example US5302954) where a signal is transmitted at each transmission at a
newly selected or set of newly selected frequencies. As each signal is received
10 at a selected frequency(s), its attributes or components can be measured or
analysed.

In another inventive aspect, there is provided an apparatus and/or
method in which a portion of the total number of receiving channels are used for
multiple device identification, and/or where another portion of the total number
15 of channels are allocated to communicate with particular device(s) being
interrogated. This has been found to reduce coincident tag signalling and
interference, thus enhancing the determination of the tag position, orientation
and/or identification within a given interrogation volume.

Another inventive aspect relates to the provision of coils formed from two
20 "L" shaped coils. This aspect is predicated on the realisation that the provision
of two "L" shaped coils enhance current balance and thus enhance field
uniformity in the interrogator.

The two "L" shaped coils are preferably juxtaposed in the interrogator to
emulate a "C" shaped coil.

25 A still further inventive aspect is directed to the problem of enhancing
communication from the tag to the interrogator. Where the article or tag
transmits a signal perpendicular to one of the interrogator coil pairs, no signal
can be established and thus the article or tag cannot be positively located or
have data associated with it. This is particularly so with airline baggage, where
30 the baggage (and its associated tag) can be randomly placed on a moving
conveyor in any orientation in any of x, y and z directions.

This aspect of the present invention is predicated on the realisation that by placing at least one of the coil pairs on an angle relative to the direction of movement of the tag through the interrogator, signal reception is less susceptible to article or tag orientation. This can apply to 1, 2 and/or 3 plane or
5 dimension structures.

A still further aspect relates to enhancement of the determination of tag position in the interrogation volume.

It has also been found that the provision of the angled receiver coils proximate the volume of interest enables signals from tag(s) to be received by
10 the interrogator where the tag(s) are positioned in any orientation.

In another aspect, the receiver coils are provided in relative close proximity to each other in order to reduce or eliminate dead zones within the volume of interest. Where the receiver coils are relatively closely spaced, they can be provided relatively closely to the volume of interest.

15 Preferably, the measuring means measures field strength of the returned field in at least the two planes.

The present invention also provides data association with at least one article whilst the article is within the interrogation area.

Preferred embodiments will now be described with reference to the
20 accompanying drawings, where 1, 2 and 3 dimension plane apparatus and methods will be disclosed, some with reference to the sorting of airline baggage. However, the present inventive aspects and principles have application in many areas, such as postal services, vehicle identification, and other areas in which there is a flow or analysis of article or object movement.
25 Generally the present invention can have application where particular and individual information relating to a device being communicated with is of use.

Furthermore, although the ensuing description is made with reference to an embodiment utilizing power ratios, an analysis of signal field, strength, power level, voltage, amplitude, and/or code sequence can equally be useful in
30 determining location, positioning, orientation and/or identification of the source of that signal.

In essence, the present invention seeks to determine location, positioning, orientation and/or identification of a signal source by analysing an attribute or component of a signal from the source which will vary within the interrogation area, depending on where in that area the signal is sourced.

5 1 Plane

Sortation is a mechanical handling issue that may be dealt with using conventional sortation equipment, however this equipment does not lend itself to full automation. At Sydney airport for example, four (4) streams of baggage on conveyors are merged onto one conveyor for transportation at high density.

10 These bags are subsequently separated and directed to their appropriate pier destination.

Discrimination of bags in such a relatively high throughput environment requires an electronic method and apparatus of identifying and locating a tag on the conveyor.

15 A tag can be located by monitoring the RF power emissions received from a tag on a receiver coil (interrogator) and comparing the power ratio for pairs of coils. Figure 1 illustrates the principle. For example, the location and/or any data received having a field strength from coil 1 of 2 power units and a field strength of coil 2 of 1 power unit can be associated with point A and thus tag 1.

20 Figure 2 shows a plot of equipower lines. These lines (planes) represent a relatively uniform field strength of a particular value between two coils.

By having knowledge of a particular signal attributes, such as field strength, within an interrogation (communication) volume, it is possible to associate that strength with that position in the volume.

25 This is based on the assumption that the articles being interrogated are relatively constant in, for example, the x and y directions and their location in the z direction is required. This may be useful in the sorting of envelopes, parcels or packages, where a substantially single flow path of packages is passed through the interrogation volume.

30 Furthermore, if the location of power "lines" B of 2 power units and 1 power unit are known within an interrogation (communication) volume, by use of the equipower line plot of Figure 2, when a signal is received from tag 1 having

coil 2 strength of 1 unit and coil 1 signal strength of 2 units, it can be deduced that tag 1 is at a particular point within the interrogation volume, represented by the power ratio as plotted in Figure 2. Thus tag 1 has been located. Accordingly, tags that are side-by-side within an interrogation volume and which
5 are communicated with at relatively the same time can be differentiated, as each tag will have a particular power ratio associated with its own unique location in the interrogation volume.

A set of paired RF receiver antenna loops preferably, but not necessarily, separate from those used for receiving and decoding tag data would be
10 required to receive the tag emissions. Each loop would require a power detector that can be scanned across all possible tag channels to ensure that all tags are detected. The details of the RF receiver antenna is described later.

2 Plane

Figure 3 shows an exemplary 2 plane interrogation area. In a 2 plane
15 area, a grid, plot or map of equipower lines or planes as shown in Figure 4. Equipower lines B represent field strengths from coils 3 and 4, and lines C represent field strengths from coils 1 and 2. This provides the ability to locate an article within the interrogation volume more precisely by the intersection of two power "planes" being accorded to receive tag power ratios. In this example, two
20 power ratios (one from each coil pair) are used to accord received data to a tag or its location. In one plane there is provided coils 1 and 2, and in the other plane are coils 3 and 4. The direction of tag or article movement is shown by arrow 5. The interrogation volume is given by "box" 6.

3 Plane

25 A three plane system has another coil pair also in the Z plane, referring to Figure 2. This would enable three power ratios to be plotted with reference to equipower lines within the interrogation volume. The three ratios would provide the ability to substantially pin-point an article (x, y and z planes) within the interrogation volume or at least within a region of the volume.

30 As the location of the tag relies on tag emissions, the tag can only be located in a plane in which it is transmitting sufficiently (above a predetermined criteria or level).

Angled Coils

In a very preferred form, the receiving coils in one, two or three planes are each angled with reference to the direction of tag movement at preferably 45°, 90° and 135° and are arranged symmetrically (see Figures 5a, 5b, 6a, 6b and 7). Each receiving coils are angled only relative to one axis or direction.

Figures 5b and 6 b are a pictorial representation showing coil formation on inner tunner (only 3 coils shown). For each of figures 5a, 5b, 6a, 6b the Z-X axis RF coils and powering coils have not been shown for clarity.

Between a pair of symmetrical coils, the ratio of received powers can define the tag location to a plane with relatively high accuracy.

By placing pairs of coils diagonally across the direction of tag movement at any angle, and preferably 45°, 90° and 135°, the location of tag can be determined by triangulation from the received powers.

An amalgamation of coils as shown in Figures 5 and 6 provides the effective interrogation volume 7 as shown in Figure 7. Where the Z-position is the only position of interest, then the necessary redundancy in location planes is provided by the 45°, 90° and 135° orientation.

Referring now to Figure 8, power from a tag will couple into coils that are oriented such that they can receive power. If an article or tag was oriented to give no Z signal, the ZY and ZX coil pairs will enable power ratios to be established and thus locate and/or associate data, such as identification, with the article or tag.

The intersection of the equipower curves would give the position of a tag transmitter provided energy from a tag couples to at least two pairs of coils (see Figure 8). To ensure that for all tag orientations this will occur three coil pairs are required. (See Figure 7).

The diagonal coils shown in Figure 7 are suitable for looking at tag transmissions in one place (say vertical-Y). Another set of diagonals lying on their side are required to look at the horizontal plane that is the X-plane.

The intersection volume between these coils is the only useable volume where unique positional information is available. To extend the size of this volume several coil pairs in the X and Y planes are necessary (see Figure 9). A

8a

single pair in the Z direction may be adequate for airline sortation, but the configuration, angle and provision of coils is application specific.

The interrogator volume is lengthened due to the provision of diagonal

5

coils on the conveyor. The position can be located to the accuracy of the intersection of the relative positions as determined from the relative power measurements (See Figure 10a and 10b) of a tag transmission.

In another form of the invention, it may be useful, particularly where a relatively large number of tags are being communicated with, to have a channel clear of co-interference from other tags during its transmission. Thus, once a tag is identified or positioned, the interrogator may acknowledge this and thus turn the particular tag "off", or put the tag into an "idle" mode, permanently or temporarily. This will facilitate speedier or clearer communication with other tags.

For example with reference to the six coils shown in Figure 10a, there may be relatively significant received power on coils C and D with negligible powers on the other coils pairs locating the tag between C and D.

The resolution required of the discrimination is preferably in the case of airline baggage 15cm maximum. Experimental measurements of the relative powers between a pair of coils show relatively good resolution (see Figure 2).

With 12 channels scanned per 1 millisecond, frequency hop rate is 12 kHz using the multiple identification patented by the present applicants; Australian patent No. 614795

$$20 \quad \frac{1\text{ms}}{12} = 83 \mu\text{s} = \frac{1}{12 \text{ kHz}}$$

Settling time of power detector <83μs.

For 20 kHz, LPF the transient response is :

$$25 \quad 20 \cdot 10^3 \cdot 2\pi = \frac{1}{t} \quad t = RC \text{ for single pole system}$$

$$t_r = 2.2t$$

Therefore $t_r = 17.5\mu\text{s}$

With additional poles we can still expect the settling time to be less than 83μs.

Hence power detector readings will accurately scan all 12 channels every 1ms.

It has already been shown that the multiple ID technology can exceed the limits proposed above and that any correctly identified tag can be located on the conveyor from its relative RF power strengths. Thus limit on performance is set by the ability for a tag to correctly identify itself.

5 A typical minimum length message is approximately 1ms being the time to transmit a 16 bit CRC at 16,500 bit/sec. Hence all 12 channels must be scanned every millisecond for power to locate a tag while a good message is being transmitted. A frequency synthesiser frequency converting to an IF with a power detector will provide a suitable system. The output from each power
10 detector is digitised and stored in a FIFO. (See Figure 11).

Alternatively, or in addition, identification positioning and/or association of data with articles or tags can be accomplished by (not necessarily in order):

1. receiving the tag signal
2. record the tag signal(s)
- 15 3. record the power readings (ratios), for example for a fraction of 1 msec.
4. review the recorded signals, in order to establish at least one complete and uncorrupted signal
- 20 5. review power ratios to ensure they are within equipower "plot" limits.

In a further form, the power ratios gained from x, y and/or z directions can be used as address data for addressing a memory (look-up table) providing location details. The memory may be a record of "field" stored in ROM.

In respect of the coils in an interrogator, coils heretofore utilize "C"
25 shaped coils. These "C" coils are, however, difficult to embody in an interrogator where the coils are set on an angle. "C" shaped coils are useful in providing the equipower lines of Figure 2.

Another aspect of the invention has therefore been realised by the use of
2 "C" shaped coils in order to radiate the power in the interrogator (Figure 2).
30 "L" shaped coils can be set on the angle, with relatively less coil extending beyond the interrogation area, as compared to "C" shaped coils.

The use of "L" shaped coils has also alleviated another problem associated with "C" coils. It has been found difficult to accurately balance current provided to each coil, particularly where equipower lines and relatively uniform powering is required for identification and/or communication with tags.

5 The "C" coils also exhibited relatively non-uniform fields proximate the corners.

These problems have been alleviated with 2 "L" coils sets as shown as 8,9 in Figure 12. The currents are balanced as the "L" coils are of substantially equal size. Fields are also more uniform, due to the relative similar shape of the "L" coils.

10 Yet a further invention has been realized by the allocation of particular transmission channels to particular tags. Where there are a relatively large number of tags to be identified within a given volume, if for example 12 channels in total were available for identification, position, orientation and/or communication, the (say) channels 1 to 6 can be used for positioning and/or
 15 multiple identification as patented by the present applicants, and (say) channels 7 to 12 could each be assigned to particular tag(s) to enhance communication and/or positioning.

"Multiple identification" technology is patented by the present applicants, for example US5302954 and AU614795. This subject matter is incorporated by
 20 reference. "Multiple identification" generally relates to, inter alia, the simultaneous identification and/or communication of at least two devices (tag(s)).

	Thus channels 1 to 6	multiple identification
	channel 7	tag 1
25	channel 8	tag 2
	channel 9	tag 3
	channel 10	tag 4
	channel 11	tag 5
	channel 12	tag 6
30	channel 7	tag 7
	channel 8	tag 8
	etc.	etc.

This type of channel allocation would provide a set channel for a particular tag's communication, thereby reducing the incidence of corruption of communication, and in addition to the multiple identification feature.

A further exemplary use of the present invention is in baggage sortation.

5 Given that the present invention is able to associate data with a particular article, it may be possible to interrogate a number of tags attached to a respective number of articles of baggage. Each tag may communicate to the interrogator, for example, the articles' particular weight and destination. The destination information is useful in directing the articles to their appropriate
10 aircraft for transport. Information regarding orientation may also be used to determine whether the article is suitably oriented for sorting or handling. This is a sortation issue.

The other information can be utilized to achieve other benefits. For example, the weight of each article will be useful in packing and loading aircraft
15 containers or indirect loading of baggage into the aircraft. Heretobefore, baggage is packed by guesstimation of weight in an attempt to evenly distribute loading of the aircraft. However, the previous guesstimation has not often been accurate, thus necessitating extra use of flaps and thus fuel during flight. This is particularly costly in international or 'long haul' flights.

20 The present invention enables a relatively high volume throughput sortation and/or multiple identification system to associate particular information with each article being identified. Thus, with the present apparatus and method, an aircraft can be loaded more accurately as the weight of each article will be known and thus loaded accordingly in the aircraft for relatively even weight
25 distribution.

Orientation

The apparatus and/or method disclosed above enables information to be gained about tag signal attributes or components. For example, it is possible to obtain a reading of a signal strength or amplitude in any one of coils used in the
30 interrogator, such as X, Y, Z coils.

By analysis of the signal strength in any one or all of these coils, it is possible to determine tag orientation. That is, the tag would transmit or reflect a

great signal strength in the direction of the coil that it was most closely oriented towards. Thus, if a relatively large signal was received in the X coil, and substantially no or little signal was received in the Y and Z coils, it can be determined that the tag is oriented toward the X coil. Where a signal was
5 received substantially equally in the X and Y coils, then the tag would be oriented at substantially 45° to each of the X and Y coils. The above is only exemplary, but is used to demonstrate that orientation information can be determined from analysis of signals received by the interrogator coils. This orientation method is applicable to one, two or three dimension interrogators.
10 The means used for analysis may be software, computer or hardware.

Other Aspects

In determining the signal attribute or component to be analysed, amplitude or strength of signal may be used. The amplitude or strength may be used where it is above a predetermined level.

15 Where multiple identification by way of the present Applicant's modulation invention is used, an interrogator may demodulate the signal received from the tag and analyse aspects, attributes and/or components of the code, information or contents of the demodulated signal. For example, amplitude, power levels may be analysed, the results of which may be equated
20 to a location, positioning and/or identification of the signal modulation source.

Receiver Coil

It is also possible to provide receiving antennas such that a tag could be received in any orientation and in any position within the volume of interest.

The embodiment described allows the receiving coils to be located
25 relatively close to the volume of interest whilst minimizing dead zones.

Boxed Coils

The box coils in figure 13 are arranged in the Z axis. If they are placed close to the volume of interest, dead zones (areas of poor tag reception) occur in the tunnel.

30 Figures 14 and 16 show three Z axis coils which allow the coils to be placed close to the interrogator substantially without a dead zone in the volume of interest.

Angled coils

Boxed coils in the Z axis do not prevent the passage of baggage through the volume of interest. X and Y boxed coils however would cause problems, especially the centre coils.

- 5 Figure 15 shows orientation of the angled receiver antenna coils which provides a relatively dead zone free volume of interest, and orientation insensitivity while still allowing the free passage of tag(s) or associated articles.

The individual sets of coils are summed thus providing two outputs.

THE CLAIMS DEFINING THE INVENTION ARE AS FOLLOWS:

1. An apparatus adapted to determine identification, position and/or orientation of a plurality of devices within an interrogation zone, the apparatus comprising:
 - means to receive a signal from each device; and
 - means to equate the received signal to a point or region in the interrogation zone based on an attribute or component of the signal.
2. An apparatus as claimed in claim 1, where the attribute is a signal power ratio.
3. A method of determining location, position, orientation and/or identification of at least one device within an interrogation area, the method comprising:
 - receiving a signal from the at least one device;
 - analysing the received signal to determine an attribute or component;
 - equating the attribute or the component to a region or point in the interrogation area.
4. A method as claimed in claim 3, wherein the step of equating is done with reference to a plot of signal attributes within the interrogation area.
5. A method as claimed in claim 4, wherein the plot comprises a plot of field strength.
6. An apparatus adapted to carry out the method as claimed in claim 3, 4 or 5.
7. In an identification system comprising an interrogator for interrogating tags, a "C" shaped coil formed from at least two "L" shaped coils.

8. In a system adapted for multiple identification, a method for enhancing the simultaneous communication with at least one device, the method comprising:
 - allocating a number of receiver channels to multiple identification; and
 - allocating at least one other channel specifically for communication with at least one of the devices.
9. The method of claim 8, as applied to two or more devices simultaneously.
10. Apparatus adapted to perform the method of claim 8.
11. An identification interrogator for interrogating a device, the interrogator comprising:
 - receiving coil(s) for receiving signals emanating from the device, at least one receiving coil being oriented at an angle relative to only one axis.
12. An interrogator as claimed in claim 10, wherein the angle is 45°, 90° or 135°.

1/9
Fig 1.

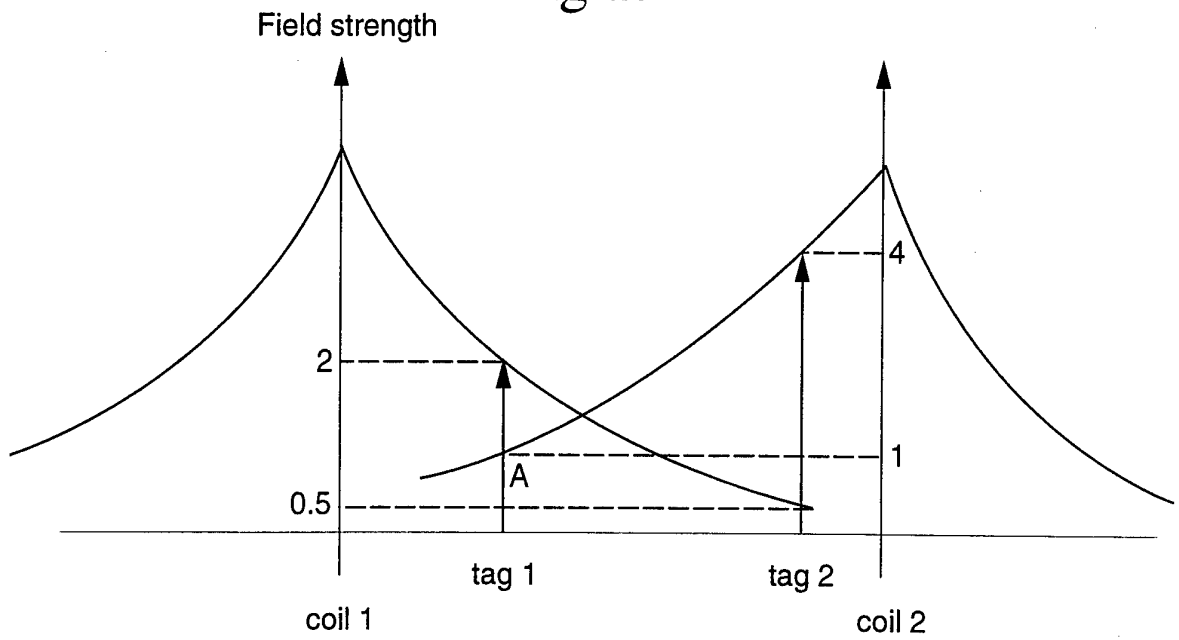

Fig 3.

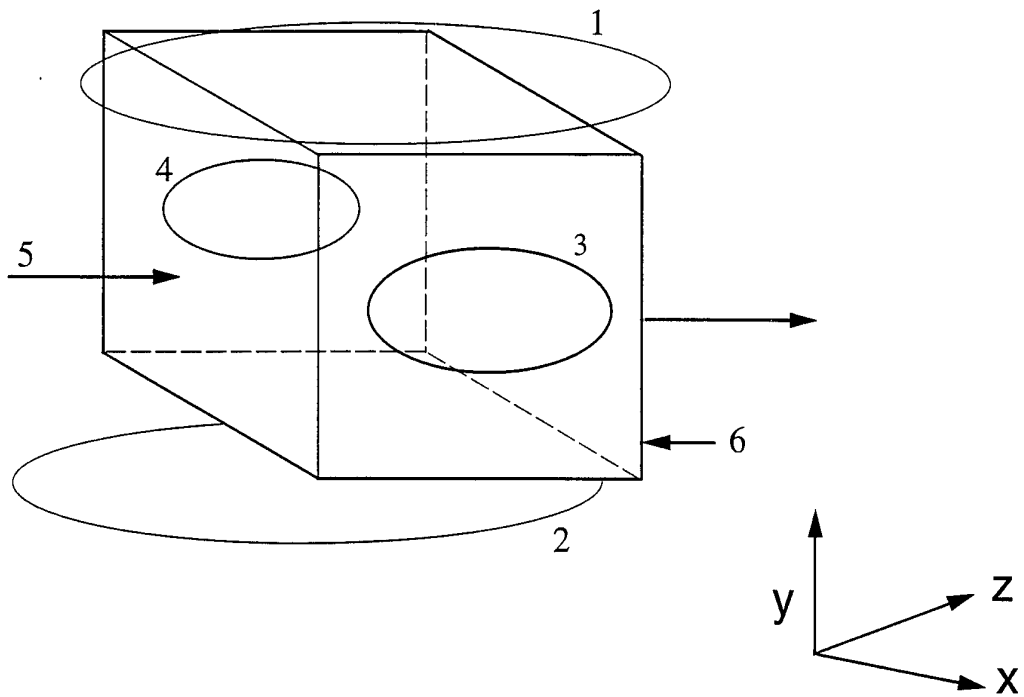
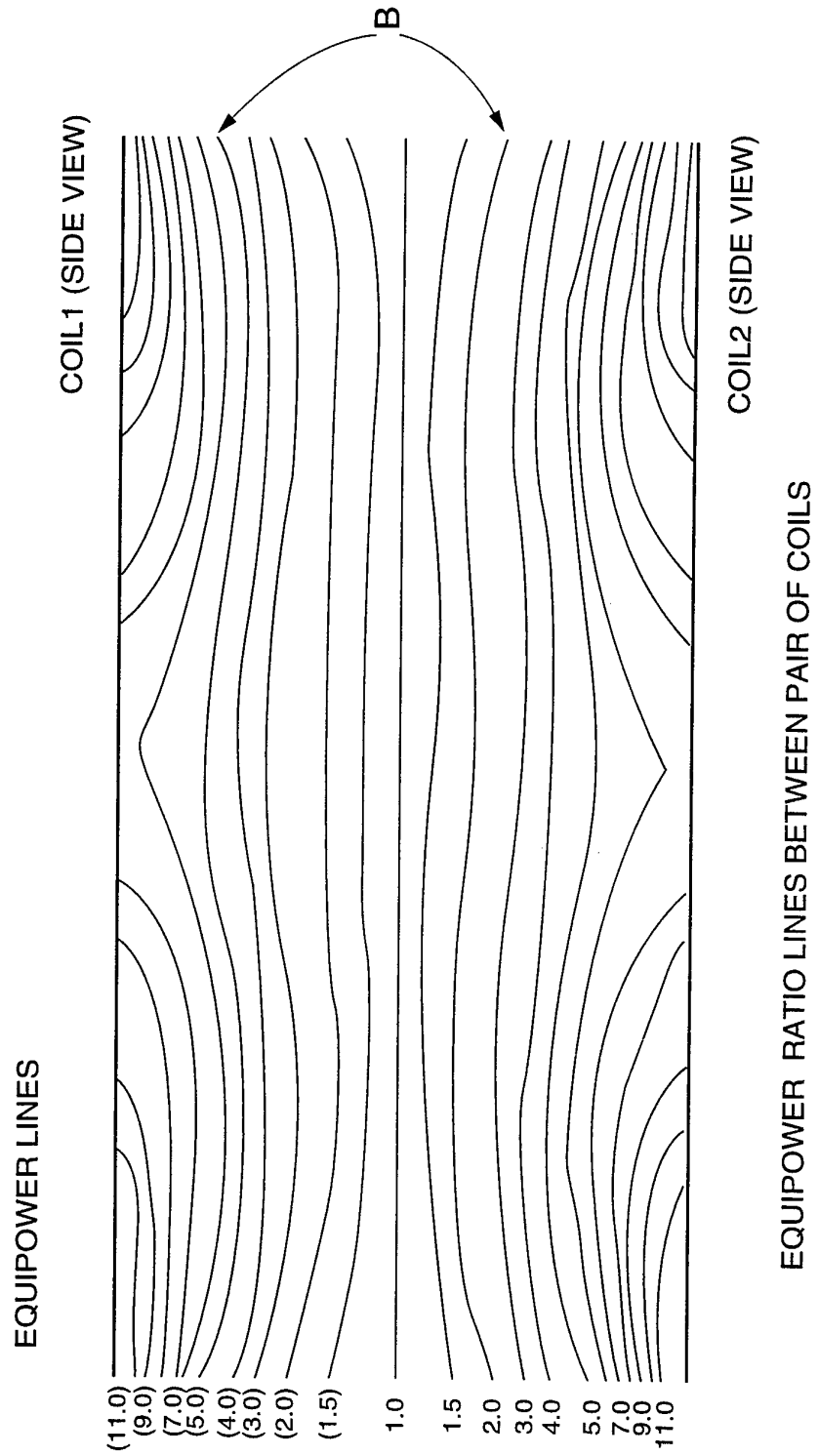

Fig 2.



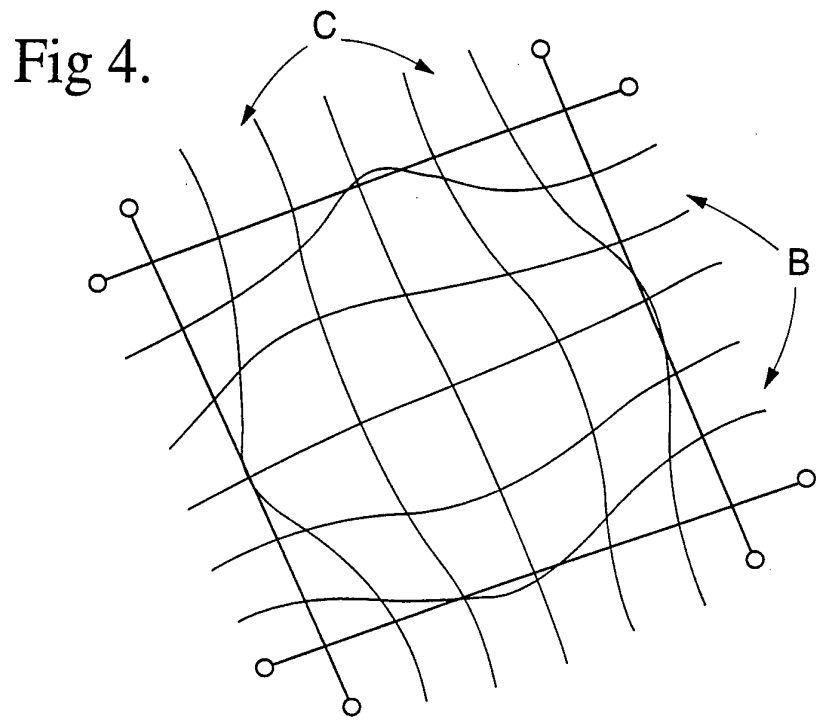

Fig 5a.

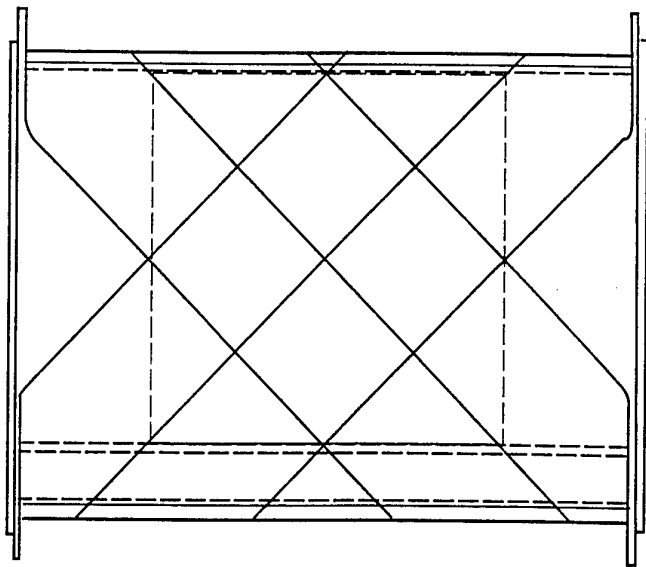

Fig 5b.

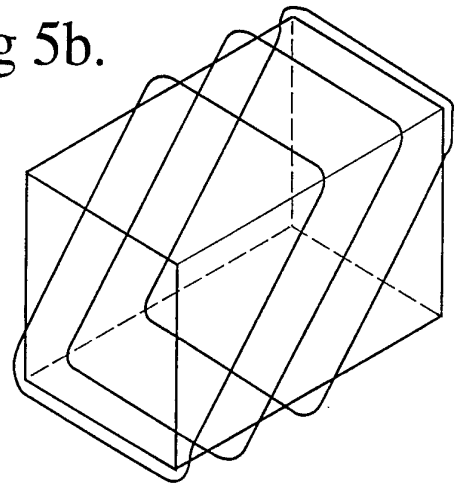

Fig 6a.

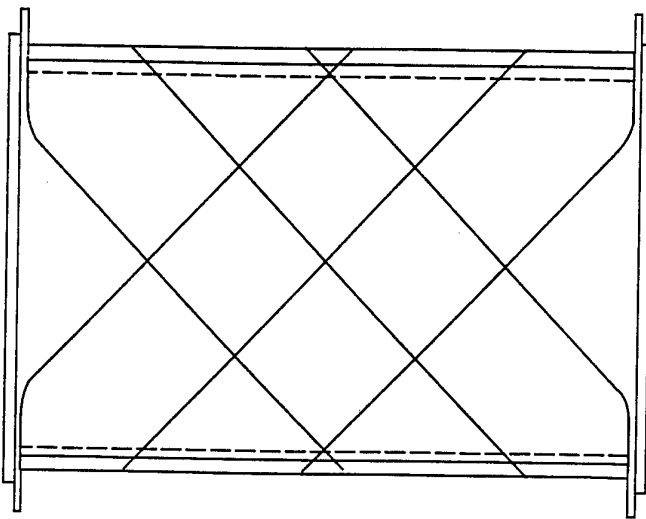

Fig 6b.

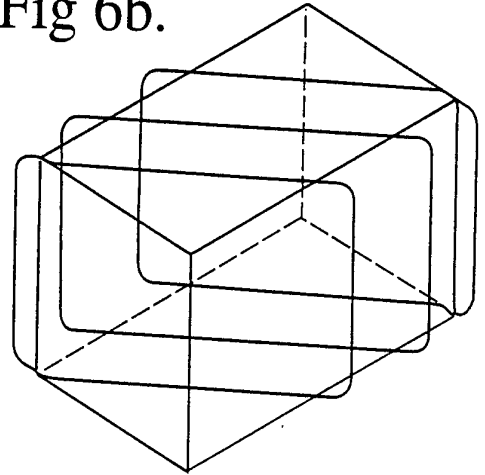

Fig 7.

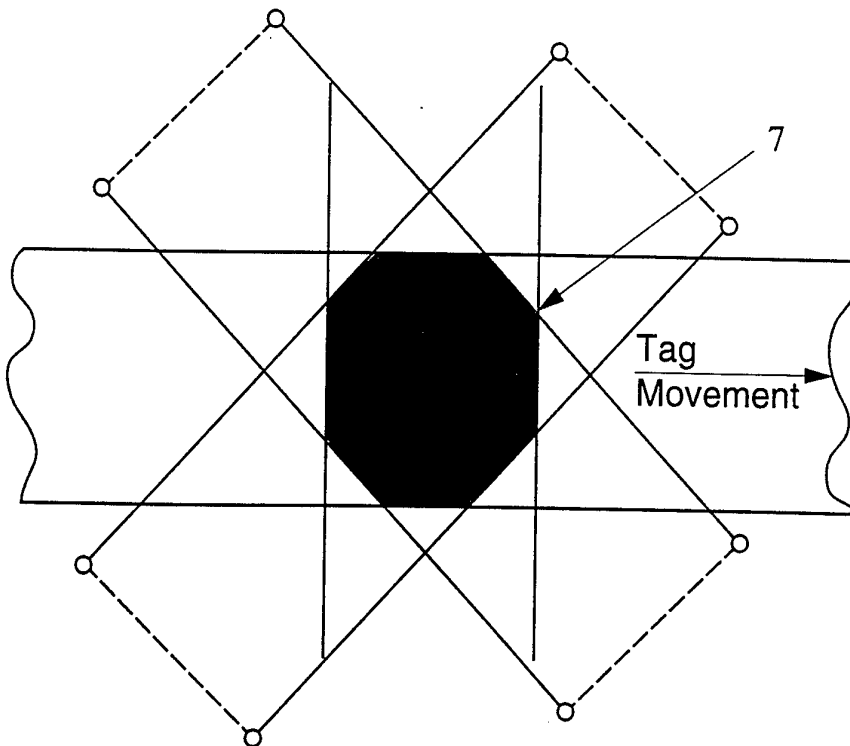

Fig 8.

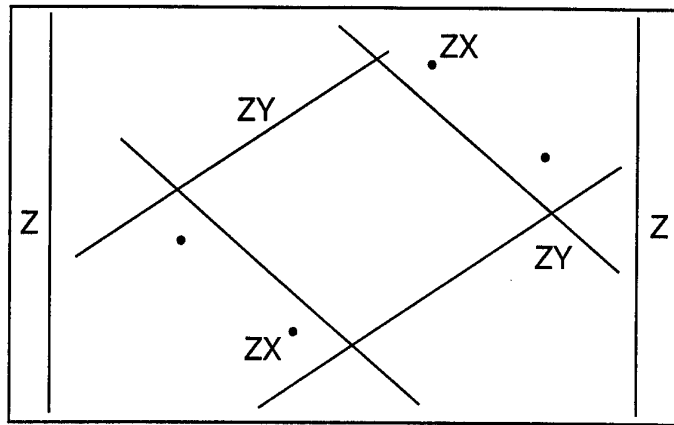

Fig 10a.

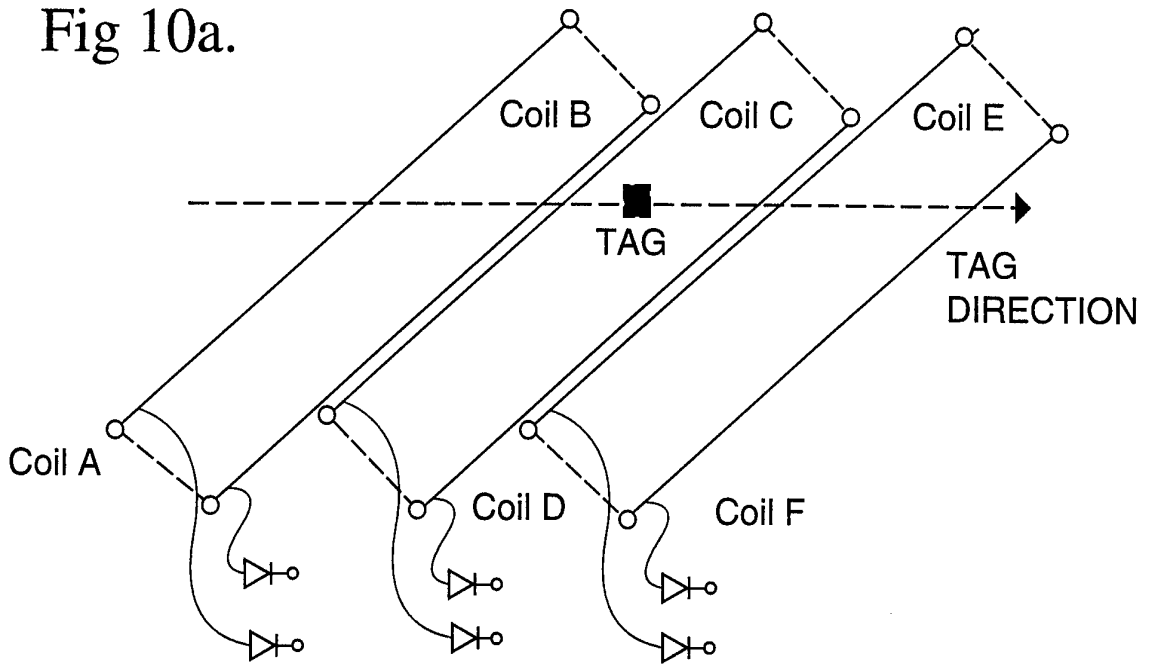
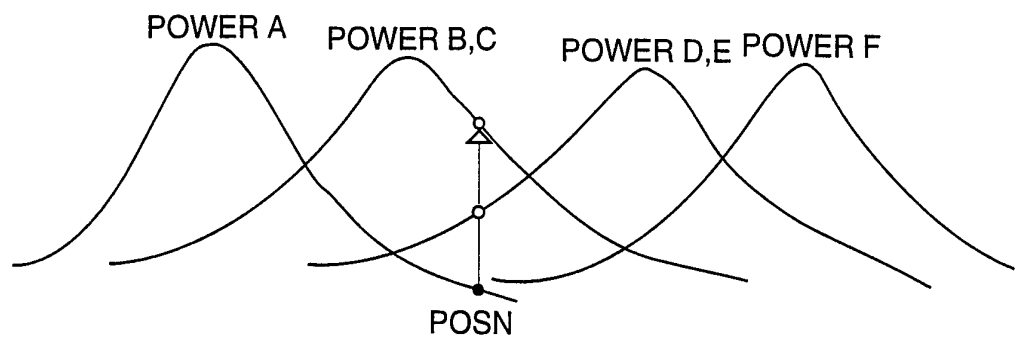
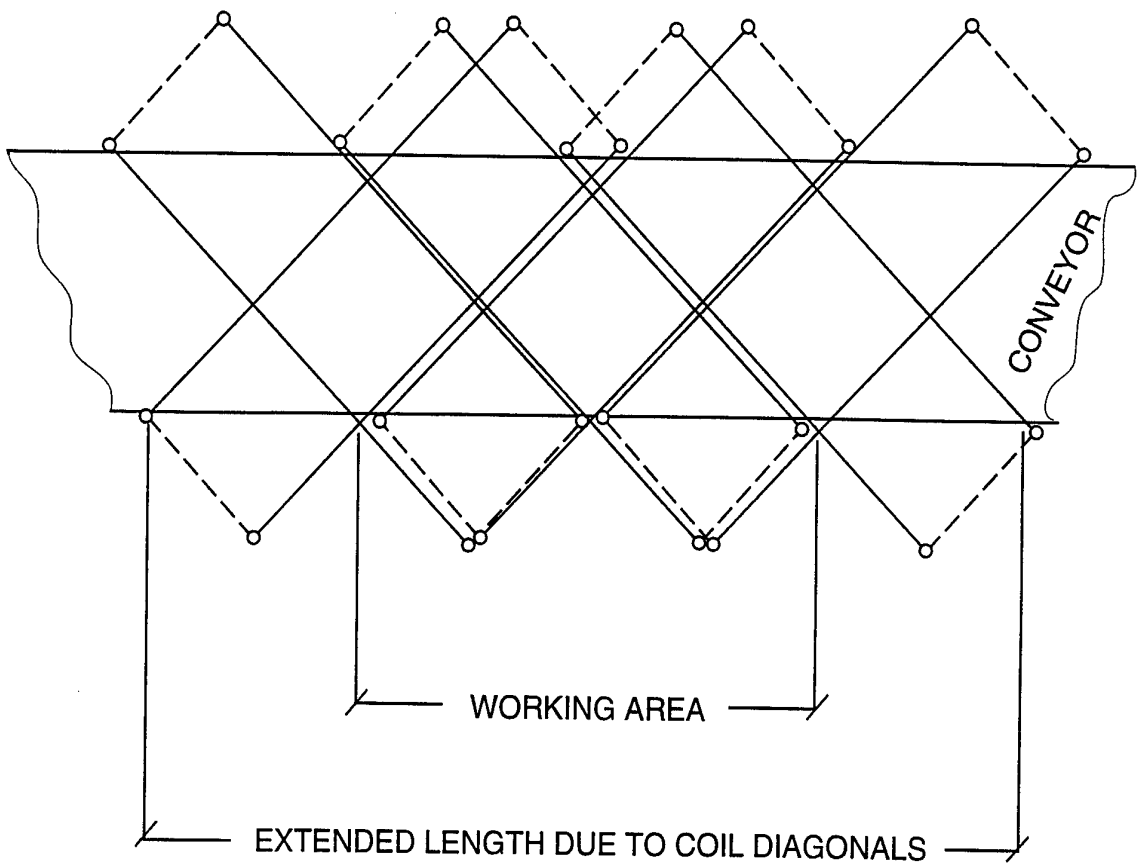

Fig 10b.



6/9

Fig 9.



7/9

Fig 11.

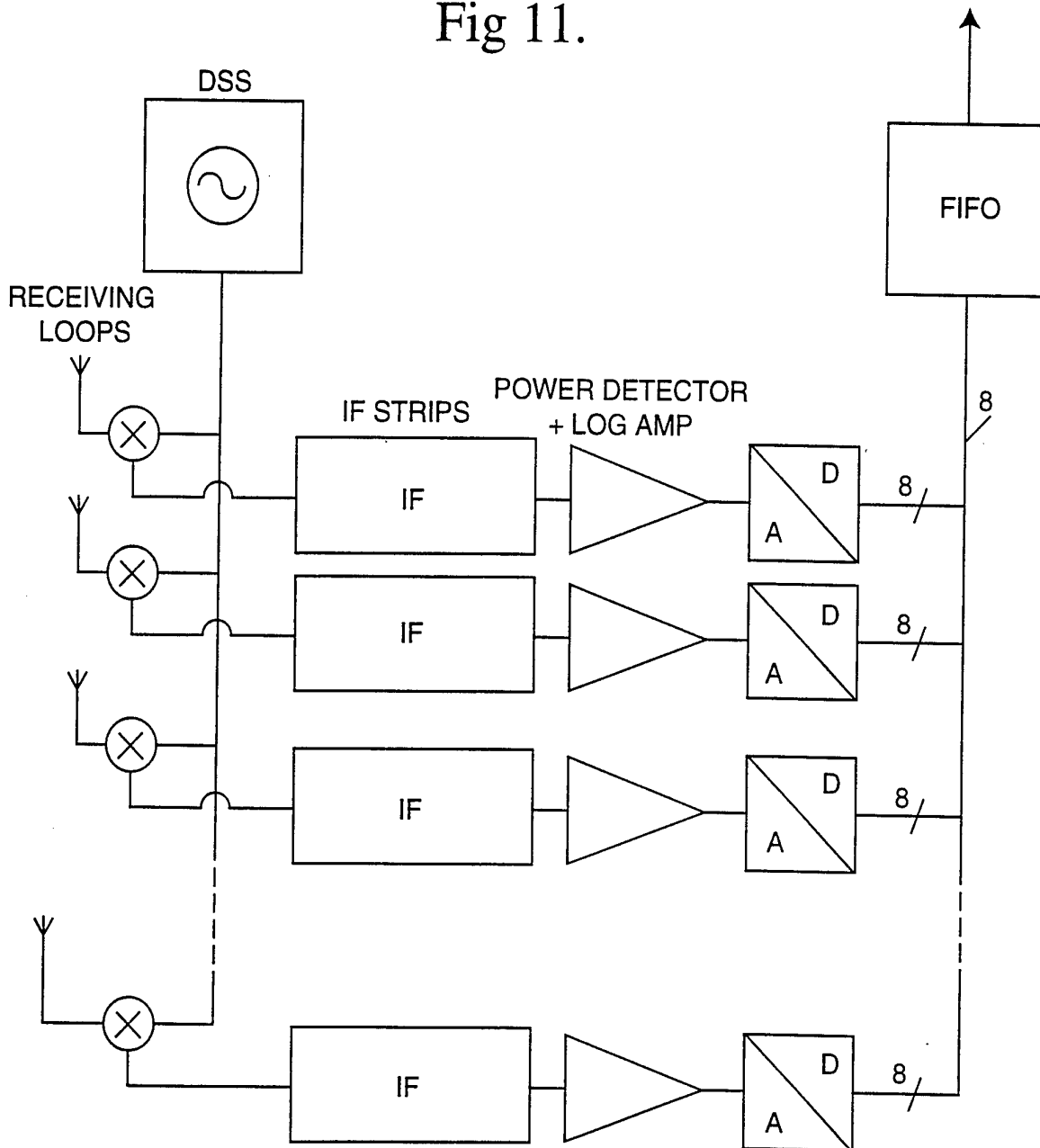
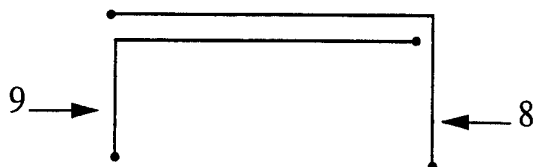

Fig 12.



SUBSTITUTE SHEET (RULE 26)

8/9

Fig 13. Two axis coils

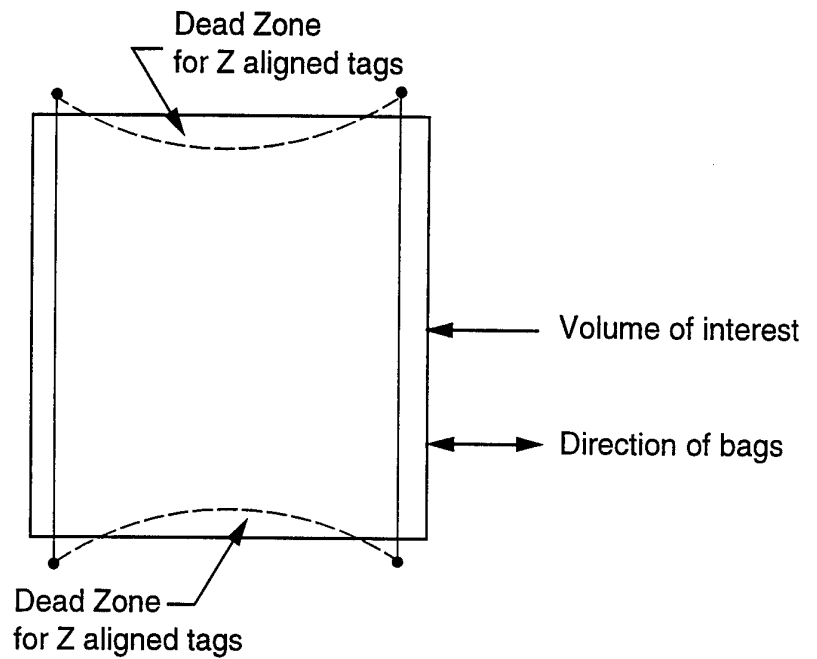

Fig 14. Three axis coils

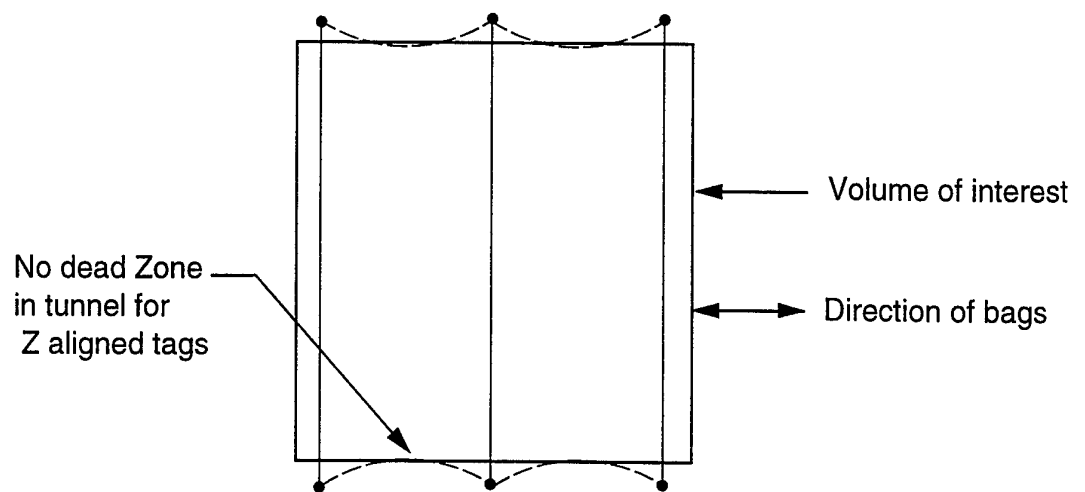

Fig 15a.

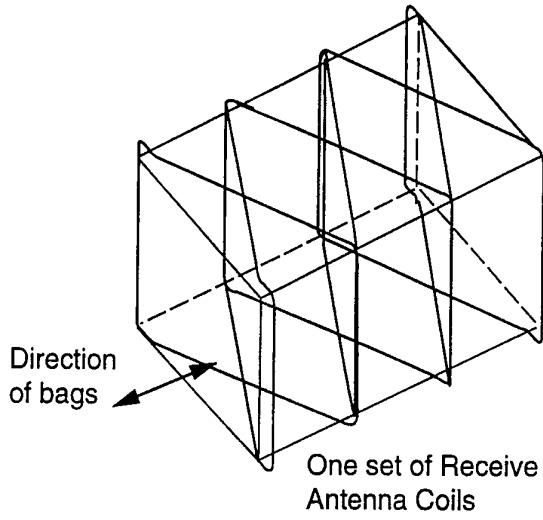

Fig 15b.

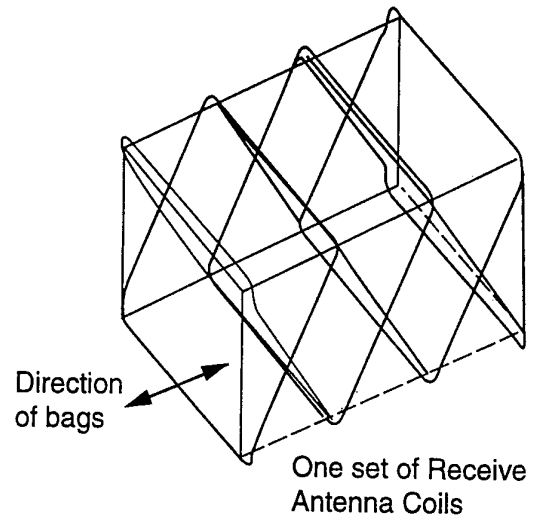
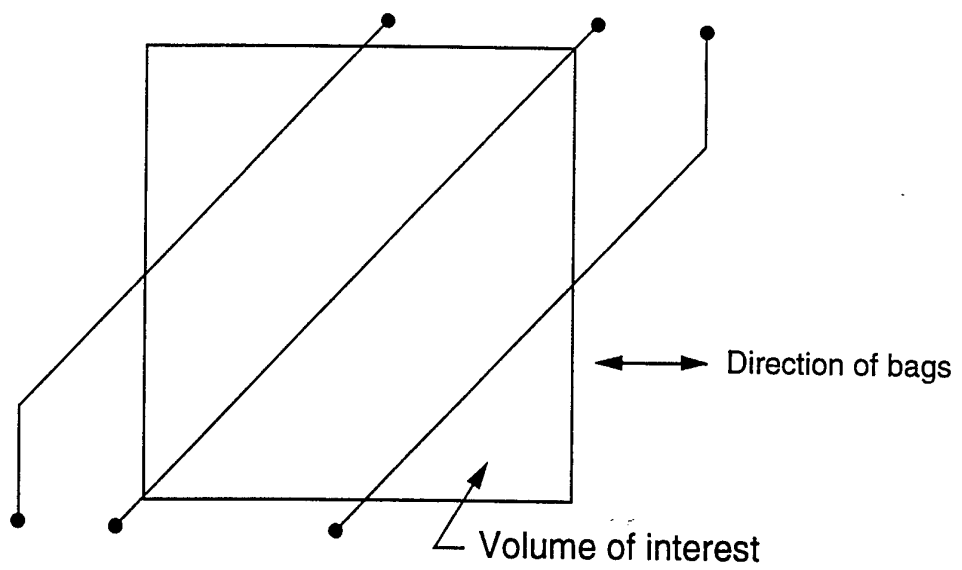

Fig 16. Angled Coils



INTERNATIONAL SEARCH REPORT

International application No.

PCT/AU 94/00731

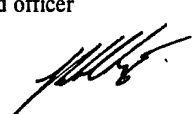
A. CLASSIFICATION OF SUBJECT MATTER Int. Cl. ⁶ G01S 13/78, G08B 13/24, G01V 3/10, H01Q 7/00 According to International Patent Classification (IPC) or to both national classification and IPC		
B. FIELDS SEARCHED Minimum documentation searched (classification system followed by classification symbols) IPC: G01S 13/78, G08B 13/24, G01V 3/10, H04B 5/00, H01Q 7/00 Documentation searched other than minimum documentation to the extent that such documents are included in the fields searched AU: IPC as above & G01S 13/76, 13/74, H04B 5/02, G01V 3/08 Electronic data base consulted during the international search (name of data base, and where practicable, search terms used) WPAT, JAPIO, JOPAL		
C. DOCUMENTS CONSIDERED TO BE RELEVANT		
Category*	Citation of document, with indication, where appropriate, of the relevant passages	Relevant to Claim No.
P,X	WO,A1, 94/19781 (N.V. NEDERLANDSCHE APPARATENFABRIEK NEDAP) 1 September 1994 (01.09.94) PAGE 1 LINES 21/26, PAGE 3 LINES 27 TO PAGE 4 LINE 5 PAGE 4 LINES 25/34, PAGE 6 LINE 18 TO PAGE 7 LINE 30 PAGE 12 LINE 29/34, CLAIM 1,15,18	1-6
<input checked="" type="checkbox"/> Further documents are listed in the continuation of Box C.		
<input checked="" type="checkbox"/> See patent family annex.		
* Special categories of cited documents :		
"A"	document defining the general state of the art which is not considered to be of particular relevance	"T" later document published after the international filing date or priority date and not in conflict with the application but cited to understand the principle or theory underlying the invention
"E"	earlier document but published on or after the international filing date	"X" document of particular relevance; the claimed invention cannot be considered novel or cannot be considered to involve an inventive step when the document is taken alone
"L"	document which may throw doubts on priority claim(s) or which is cited to establish the publication date of another citation or other special reason (as specified)	"Y" document of particular relevance; the claimed invention cannot be considered to involve an inventive step when the document is combined with one or more other such documents, such combination being obvious to a person skilled in the art
"O"	document referring to an oral disclosure, use, exhibition or other means	"&" document member of the same patent family
"P"	document published prior to the international filing date but later than the priority date claimed	
Date of the actual completion of the international search 10 February 1995 (10.02.95)	Date of mailing of the international search report 15 Feb 1995 (15.2.95)	
Name and mailing address of the ISA/AU AUSTRALIAN INDUSTRIAL PROPERTY ORGANISATION PO BOX 200 WODEN ACT 2606 AUSTRALIA Facsimile No. 06 2853929	Authorized officer  R FINZI Telephone No. (06) 2832213	

INTERNATIONAL SEARCH REPORT

C(Continuation). DOCUMENTS CONSIDERED TO BE RELEVANT		
Category *	Citation of document, with indication, where appropriate of the relevant passages	Relevant to Claim No.
X	WO,A1, 93/14478 (RSO CORPORATION.N.V) 22 July 1993 (22.07.93) PAGE 1 LINES 28/32. PAGE 7 LINE 19 TO PAGE 8 LINE 14. PAGE 8 LINE 32 TO PAGE 9 LINE 9. PAGE 10 LINES 3/9. PAGE 11 LINE 32 TO PAGE 12 LINE 5. PAGE 13 LINE 9/22.	1-6
X	WO,A1, 93/06433 (INDUSTRIAL CONTRACTORS HOLLAND B.V.) 1 April 1993 (01.04.93) PAGE 4 LINE 13/36. PAGE 7 LINE 20 TO PAGE 8 LINE 22. PAGE 11 LINE 1/5.	1-6
X	US,A 5001458 (TYREN et al) 19 March 1991 (19.03.91) COLUMN 2 LINE 44 TO COLUMN 3 LINE 33.	1-6
X	US,A, 4642786 (HANSEN) 10 February 1987 (10.02.87) CLAIMS 1,7,8 COLUMN 2 LINE 59 TO COLUMN 4 LINE 12	1-6
X	GB,A, 2155720 (STANDARD TELEPHONES AND CABLES PUBLIC LIMITED COMPANY (UNITED KINGDOM)) 25 September 1985 (25.09.85) CLAIM 1. PAGE 1 LINE 103/121	1-6
X	US,A, 5258766 (MURDOCH) 2 November 1993 (02.11.93) FIGURES 1,8 COLUMN 6 LINES 8/12,31/41 CLAIM 1.	11,12
X	US,A, 5221831 (GEISZLER) 22 June 1993 (22.06.93) COLUMN 2 LINES 22/27 COLUMN 4 LINE 49 TO COLUMN 5 LINE 30. CLAIM 1	11,12
X	WO,A1, 86/02186 (SAAB AUTOMATION AB) 10 April 1986 (10.04.86). PAGE 3 LINES 18/25. PAGE 4 LINES 23 TO PAGE 5 LINE 8 FIGURE 2	11,12
X	EP,A1, 0496609 (TEXAS INSTRUMENTS HOLLAND B.V.) 29 July 1992 (29.07.92) COLUMN 1 LINE 17 TO COLUMN 2 LINE 38 CLAIM 1, FIGURE 2	11,12

INTERNATIONAL SEARCH REPORT

PCT/AU 94/00731

Box I Observations where certain claims were found unsearchable (Continuation of Item 1 of first sheet)

This international search report has not established in respect of certain claims under Article 17(2)(a) for the following reasons:

1. Claims Nos.:
because they relate to subject matter not required to be searched by this Authority, namely:

2. Claim Nos.:
because they relate to parts of the international application that do not comply with the prescribed requirements to such an extent that no meaningful international search can be carried out, specifically:

3. Claims Nos.:
because they are dependent claims and are not drafted in accordance with the second and third sentences of Rule 6.4(a).

Box II Observations where unity of invention is lacking (Continuation of item 2 of first sheet)

This International Searching Authority found multiple inventions in this international application, as follows:

The International Application does not comply with the requirements of unity of invention because it does not relate to one invention or to a group of invention so linked as to form a single general inventive concept. On coming to this conclusion the International Searching Authority has found that there are four inventions:

1. Claims 1-6 are directed to a apparatus/method which receives a signal from a device, analyses the signal, equates an attribute/component of the signal to a region/point in the interrogation zone/area.
It is considered that the provision of the equating of an attribute/component of the signal to a region/point in the interrogation zone/area is the first special technical feature.
2. Claim 7 is directed to an interrogator system having an interrogator comprising a C shaped coil formed from 2+L shaped coils is the second special technical feature.
It is considered that the C shaped coil formed from 2+1 shaped coils is the second special technical feature.
3. Claim 8-10 are directed to a system for multiple identification using the method of allocating a number of receiver channels for multiple identification and allocating 1+ other channels specifically for communication 1+ devices.
It is considered that the allocation of receiver channels for multiple identification and other channels specifically for communication with a device is the third special technical feature.
4. Claims 11-12 are directed to an interrogator having receiver coils for receiver coils for receiving signals from the device where 1+ coils have a particular angular orientation to an axis.
It is considered that the orientation of the coils is the fourth special technical feature.
Since the above mentioned groups of claims do not share any of the technical features identified, a "technical relationship" between the inventions, as defined in PCT rule 13.2 does not exist. Accordingly the international application does relate to one invention or to a single inventive concept.

1. As all required additional search fees were timely paid by the applicant, this international search report covers all searchable claims
2. As all searchable claims could be searched without effort justifying an additional fee, this Authority did not invite payment of any additional fee.
3. As only some of the required additional search fees were timely paid by the applicant, this international search report covers only those claims for which fees were paid, specifically claims Nos.: 1-6, 11-12
4. No required additional search fees were timely paid by the applicant. Consequently, this international search report is restricted to the invention first mentioned in the claims; it is covered by claims Nos.:

Remark on Protest

- The additional search fees were accompanied by the applicant's protest.
- No protest accompanied the payment of additional search fees.

INTERNATIONAL SEARCH REPORT

international application no.

PCT/AU 94/00731

This Annex lists the known "A" publication level patent family members relating to the patent documents cited in the above-mentioned international search report. The Australian Patent Office is in no way liable for these particulars which are merely given for the purpose of information.

Patent Document Cited in Search Report		Patent Family Member					
WO	9419781	NL	9300290				
WO	9314478	AU	34135/93	AU	36518/93	EP	623237
		EP	624241	EP	626666	EP	627106
		SE	9200145	SE	9203258	SE	9203479
		WO	9314370	WO	9314474		
WO	9306433	AU	26688/92	NL	9101615		
US	5001458	AU	78064/87	CA	1279386	EP	330656
		ES	2011307	WO	8801427		
US	4642786						
GB	2155720	AU	39116/85				
US	5258766	AU	28013/89	EP	393103	EP	608966
		WO	8905530	ZA	8809254		
US	5221831	AU	32248/93	EP	614556	WO	9311504
WO	8602186	SE	8404876				
EP	496609	JP	4315980	NL	9100109		
END OF ANNEX							