

J. W. JOHNSON.
 WOOD EXTRACTING DEVICE.
 APPLICATION FILED SEPT. 16, 1908.

997,557.

Patented July 11, 1911

3 SHEETS-SHEET 2.

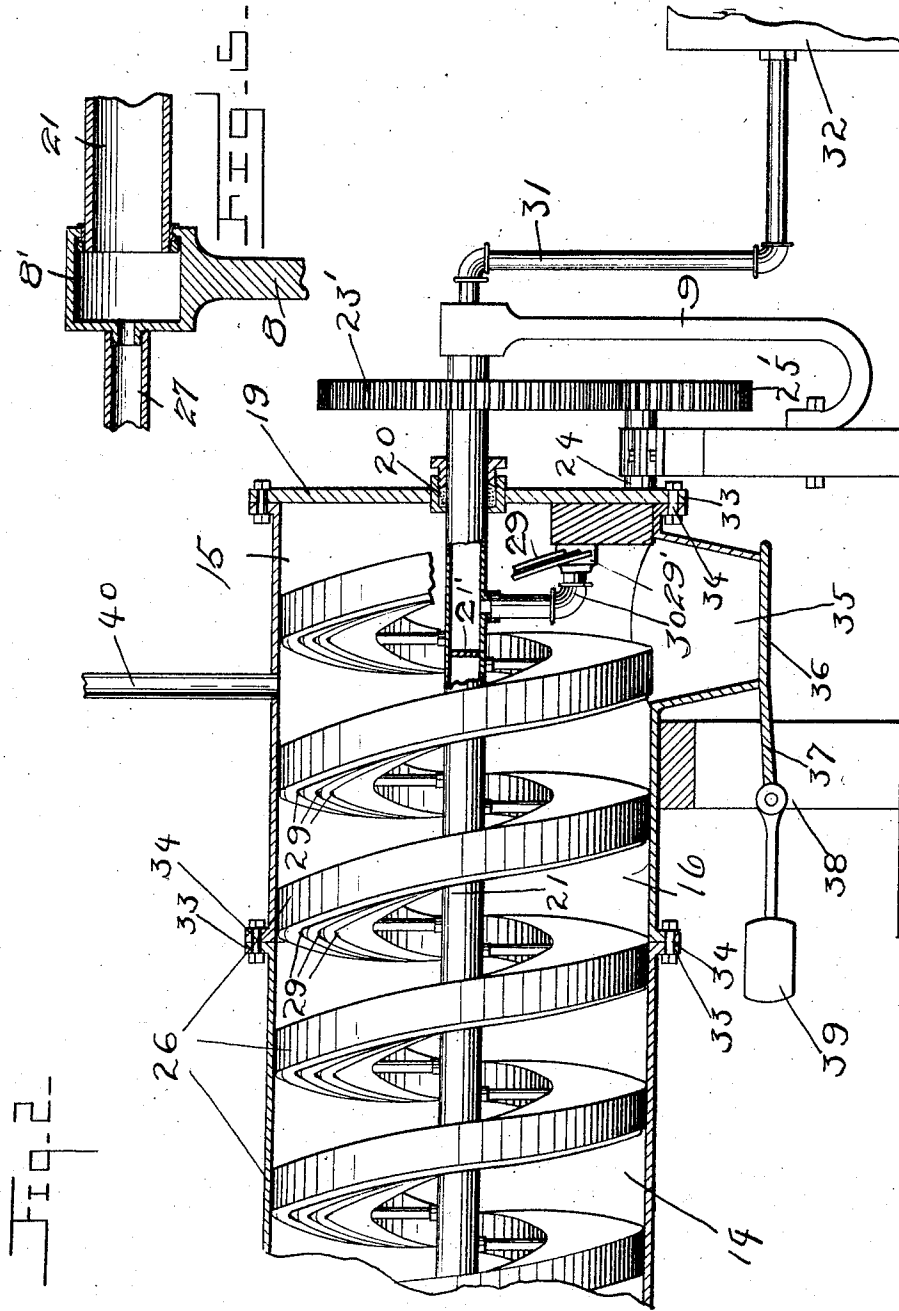

FIG. 2-

Inventor

John W. Johnson.

Witnesses

J. W. Johnson
E. L. Chandler

By

Woodward Chandler

Attorney

J. W. JOHNSON.
 WOOD EXTRACTING DEVICE.
 APPLICATION FILED SEPT. 16, 1908.

997,557.

Patented July 11, 1911.

3 SHEETS—SHEET 3.

Fig. 3-

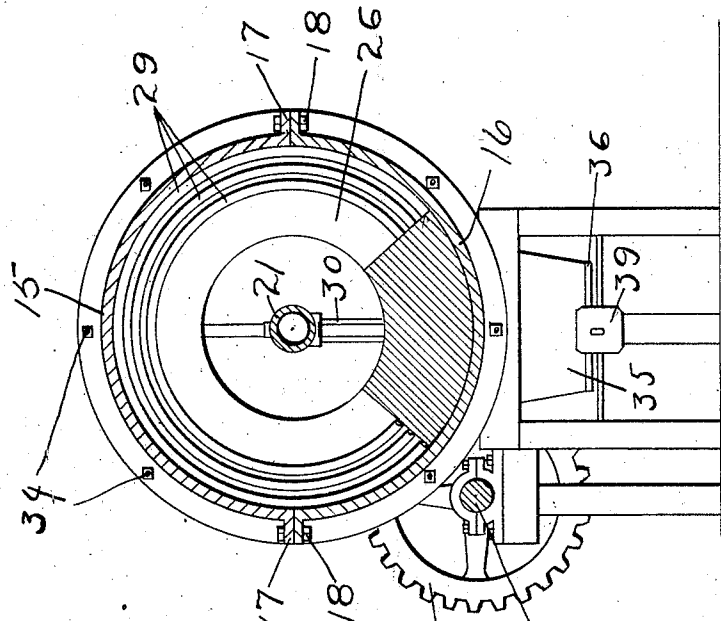
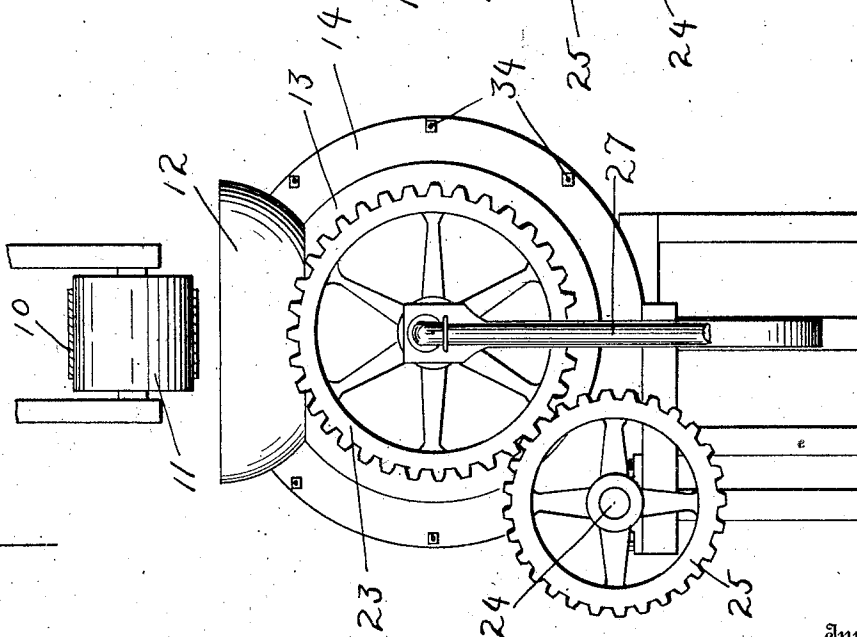

Fig. 4-



Inventor

John W. Johnson.

Witnesses
Jurvelles

E. L. Chandler

By *Woodward & Chandler*

Attorney

UNITED STATES PATENT OFFICE.

JOHN W. JOHNSON, OF JACKSONVILLE, FLORIDA.

WOOD-EXTRACTING DEVICE.

997,557.

Specification of Letters Patent. Patented July 11, 1911.

Application filed September 16, 1908. Serial No. 453,354.

To all whom it may concern:

Be it known that I, JOHN W. JOHNSON, a citizen of the United States, residing at Jacksonville, in the county of Duval and State of Florida, have invented certain new and useful Improvements in Wood-Extracting Devices, of which the following is a specification.

This invention relates to extracting devices and has special reference to a device of this character which will extract turpentine and other products of wood from the same.

An object of this invention is to produce a device of this character which is simple in construction so that easy access may be obtained to the working parts thereof when repairs or cleaning is necessary.

The invention has for a further object the provision of novel means for heating the retort employed and of novel means for feeding the wood into the retort.

Other objects and advantages will be apparent from the following description and it will be understood that changes in the specific structure shown and described may be made within the scope of the claims without departing from the spirit of the invention.

In the drawings forming a portion of this specification, and in which like numerals of reference indicate similar parts in the several views, Figure 1 is a longitudinal vertical section of the forward end of the device, Fig. 2 is a longitudinal vertical section of the rear end of the same, Fig. 3 is a section on the line 3-3 of Fig. 1, Fig. 4 is an end elevation of the device.

Referring to the drawings, 10 designates a conveyer upon which sawdust or wood shavings are deposited from which the substances are to be extracted. The conveyer is supported at its inner end upon a roller 11 which is directly disposed above a hopper or receiving box 12 which is directly connected to a feeding chamber 13 through which a limited amount of the wood shavings is admitted to the retort 14 positioned adjacent the feeding chamber 13. The chambers 12, 13 and 14 are formed of cylindrical

casings of various diameters which are composed of semicircular sections 15 and 16 which are flanged at their adjoining edges as at 17 through which are passed bolts 18 for detachably securing the same together. The hopper 12 is opened at its upper end for the reception of the wood shavings which are deposited therein and which are conducted to the adjacent feeding chamber 13 which is entirely inclosed and is circular in cross section, where the shavings are passed through the same and conducted into the retort 14 which is of a large diameter and is also circular in cross section. The opposite extremity of the retort 14 is closed by a cap 19 which is centrally apertured and through which is secured a stuffing box 20 to receive one extremity of a shaft 21 which is longitudinally disposed through the retort 14, feeding chamber 13 and is supported in a journal 22 formed in the outer wall of the hopper 12. Partitions 21' are arranged in the hollow shaft 21, within the retort and adjacent to either end thereof. The shaft 21 is provided with gears 23 and 23' disposed upon the opposite extremities thereof and which are connected to a drive shaft 24 through the medium of pinions 25 and 25'. The shaft 21 is provided intermediately thereof with helical wings 26 which are disposed about the shaft with a diameter equal to that of the retort 14. Wings 26 which are a continuation of the wings in the feeding drum also extend to the forward end of the device through the feeding-drum 13 and hopper 12 where they are considerably reduced in diameter to conform to the sizes of those chambers. The forward end of the shaft 21 is bored centrally to a point within the retort 14 through which steam is conducted from a feed pipe 27 leading from any suitable steam supply, the shaft 21 being connected to a radially extending pipe 28 which leads to a plurality of coil pipes 29 disposed upon the wings 26. The coil pipes 29 extend about the wings 26 the entire length of the retort 14 where they are connected to a radially extending pipe 30 which conducts the condensed steam into the rear bored por-

tion of the shaft 21 where it is conducted through the stuffing box 20 connecting pipe 31 and into a suitable steam trap 32.

It will be seen from reference to the drawings that the partitions 21' are located between the radially extending steam pipes 28 and 30 which are connected to either end of the coil pipes 29. Thus the steam will not pass entirely through the pipe 21, but will be directed by the forward partition 21' into the pipe 28 and conveyed to the coils 29. After the steam has passed through the coils and from the pipe 30 into the rear end of the shaft 21, the rear partition plate will prevent any forward movement of the steam, so that the same will be carried off by the pipe 31 to the steam trap 32.

The casing forming the chambers 12, 13 and 14 is formed in circular sections which are flanged as at 33 at their opposite extremities which are secured together by suitable bolts 34. This enables the operator to gain access into the central portion of the apparatus without much difficulty and without having to knock down the complete apparatus.

At the rear extremity of the retort 14 an outlet chamber 35 is disposed upon the under side thereof which is provided with a bottom 36 which is supported upon a forward extremity of the lever 37 which is fulcrumed upon a standard 38 and which is provided upon its rear end with a weight 39. By this action and construction the bottom 36 is closed by the weights and is automatically opened when a sufficient quantity of the wood shavings are deposited in the chamber 35. For the purpose of conveying the vapors from the retort 14 pipes 40 are positioned upon the upper side of the retort 14 which lead to suitable condensers or the like.

The wings 26 are supported about the shaft 21 upon the outer extremities of the radially extended arms 42 which are carried by the shaft 21 and engage the inner edges of the wings 26 in any convenient manner.

The operation of the device is as follows: Sawdust or wood shavings are placed upon the conveyer 10 and fed into the upper open end of the hopper 12. The shaft 21 is set in motion and the wings 26 are revolved and caused to carry the wood shavings into the feeding chamber 13. The shavings are conducted from the feeding chamber 13 into the retort 14 which is of enlarged diameter and is provided with the steam pipes 29. The purpose of having the drum 13 of reduced diameter from that of the retort 14 is to limit the amount of shavings conducted into the retort so that the greatest efficiency possible may be obtained from the apparatus disposed in the retort 14. Steam

is admitted through the feed pipe 27 through the hollow upper end 8' of the arm 8 and into the forward end of the shaft 21 where it travels to the retort 14 and is conducted into the radially extending pipe 28. The pipe 28 delivers steam into the first steam box 29', from which box it passes into the pipes 29 and is by them delivered to a second box 29', from which it passes through the pipe 30, into the portion of 21 which is to the right of the partition 21', shown on Fig. 2. From this portion of 21 it passes into the hollow upper end 9' of the arm 9, thence through the pipe 31 and into the trap 32. If it is desired to gain access to the inside of the casing it is only necessary to remove the bolts 18 and 33 and to raise the sections 15 and 16 out of position. The shavings are conducted through the retort 14 to the rear end thereof where they are deposited in the outlet chamber 35. When a predetermined quantity of shavings have been deposited upon the bottom 36 in the chamber 35 they overcome the weight 39 and the bottom 36 falls downwardly allowing the escape of the wood shavings. The weight 39 then returns the bottom 36 to its closed position. The vapors which are generated by the action of the heat produced by the coils 29 upon the wood shavings are conducted through the pipe 40 to condensers or the like where they may be refined and prepared for use.

When the wood shavings or sawdust is very dry it is desirable to moisten the same by the direct application of steam. This is effected by the employment of steam pipes 41 which are positioned in the lower portion of the retort 14 at the feeding end of the same.

What is claimed is:—

1. In a device of the class described, the combination of a casing divided into a hopper, a feeding chamber and a retort, a shaft longitudinally disposed in said casing, spiral wings disposed about said shaft, coiled pipes disposed upon the rear faces of said wings in the retort, said shaft being hollowed intermediately thereof for the purpose of conveying steam therethrough to said coiled pipes, an outlet chamber disposed at one extremity of said casing, a bottom pivotally disposed beneath said chamber, a weight mounted upon a projection carried by said bottom for the purpose of normally holding the same in a closed position and means for actuating said shaft.

2. In a device of the character described, the combination of a casing, said casing comprising a plurality of semi-cylindrical sections and flanges formed upon the opposite ends of said sections for engagement with one another to be secured in such position by bolts passed therethrough, a heli-

cally formed conveyer mounted longitudinally through said casing, coiled pipes disposed on said helical conveyer in the retort of said casing, the shaft of said conveyer
5 being bored at its opposite extremities for conveying steam to said coiled pipes and means for rotating said conveyer.

In testimony whereof I affix my signature, in presence of two witnesses.

JOHN W. JOHNSON.

Witnesses:

D. K. CATHERWOOD,
LOUIS W. BAKER.