

May 22, 1934.

W. K. WESTON

1,960,036

AIR INSULATED CONDUCTOR

Filed Aug. 13, 1929

2 Sheets-Sheet 1

FIG. 1

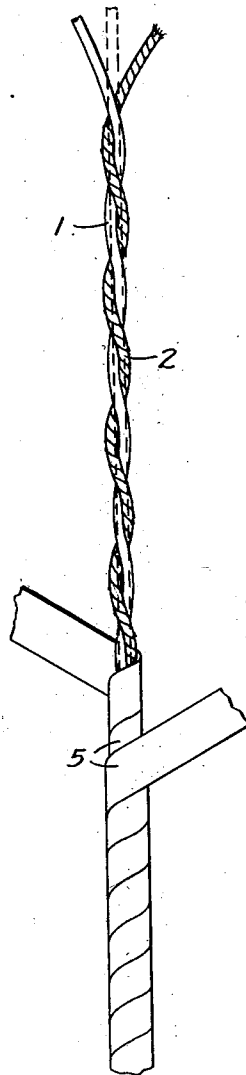
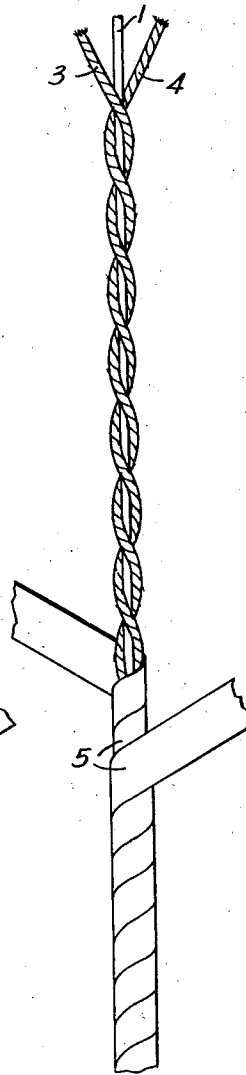

FIG. 2



INVENTOR
W. K. WESTON

BY *J. W. Schmied*
ATTORNEY

May 22, 1934.

W. K. WESTON
AIR INSULATED CONDUCTOR

1,960,036

Filed Aug. 13, 1929

2 Sheets-Sheet 2

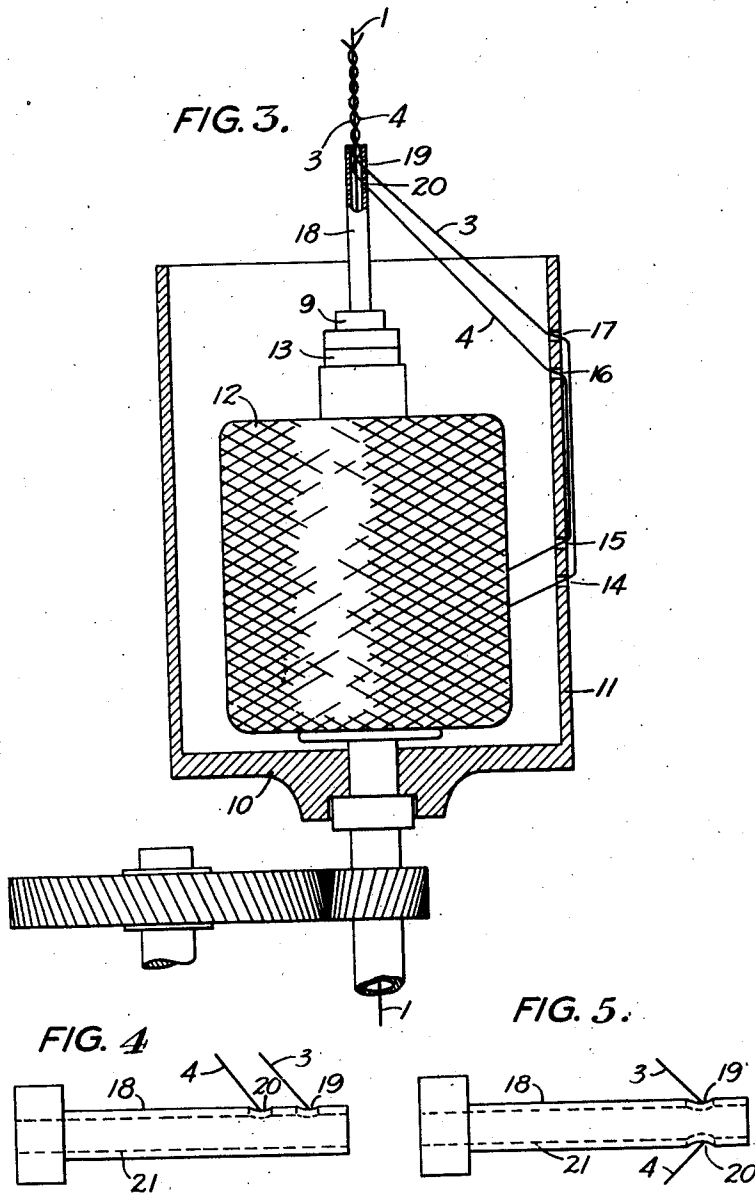

INVENTOR
W. K. WESTON
BY *J. W. Schmied*
ATTORNEY

UNITED STATES PATENT OFFICE

1,960,036

AIR INSULATED CONDUCTOR

William Kirby Weston, Sanderstead, England, assignor to Western Electric Company, Incorporated, New York, N. Y., a corporation of New York

Application August 13, 1929, Serial No. 385,661
In Great Britain November 16, 1928

5 Claims. (Cl. 173—265)

This invention relates to improvements in insulated electrical conductors and more particularly to air-spaced paper insulated conductors used in telephone cables or the like.

the speed of the paper serving head, with the result that the output of the machine is no longer limited by the speed of the string serving head. The speed of the machine can, therefore, be increased with a consequent increase in output of the machine.

The invention will be more fully understood from the following description taken in conjunction with the accompanying drawings.

Fig. 1 shows a conducting core wrapped in known manner with an open spiral of string.

Fig. 2 shows a core wrapped with two strings placed diametrically opposite one another round the core according to the present invention.

Fig. 3 shows a string applying head suitable for carrying out the invention.

Fig. 4 shows a string applying guide for applying two strings to the core.

Fig. 5 shows another type of guide for applying two strings to the core.

In Fig. 1 is shown a core 1 which is wrapped with a string 2. It is essential that this core 1 remains straight so as to maintain its central location with respect to the insulating paper envelope 5 which is subsequently to be applied. The main purpose of string insulation is to keep the core centrally located within the paper envelope 5, as any displacement would affect the effective capacity value of the conductor when assembled into a cable. In practice, however, it is found very difficult to avoid a certain amount of deformation of the wire when the string is applied. The very high speed with which the string is applied is the cause of a considerable pull on the conductor at the point of application and the result of this pull is that the conductor exhibits after application of the string a greater or lesser degree of spiralling corresponding to the lay of the string. This effect is indicated in Fig. 1 where the spiralling effect of the core 1 due to the pull of the string 2 on application is shown with full lines.

Fig. 2 shows a core 1 to which two separate strings 3 and 4 are applied in accordance with the invention. These two strings 3 and 4 are so spaced that one falls exactly mid-way between the adjacent turns of the other. In other words the strings occupy at any cross-section of the conductor positions which are diametrically opposite to one another and the pull of one string is counteracted by the pull of the other. The counteracting effect can be improved still further if the strings are applied with the same pull—for instance, from the same bobbin, as described further on in this specification.

5 In the manufacture of what is known as string insulated conductors, a string is applied to the conducting core or wire in an open spiral and the string insulated core is then wrapped with paper tape.

10 In the manufacture of string insulated conductors there is a tendency of the wire to become deformed by the application of the string, which at the very high speed at which it runs produces a considerable pull on the conductor at the point of application. The result of this pull is that the conductor frequently exhibits to a greater or lesser degree a spiral formation corresponding to that of the string. This spiralling has the effect of reducing the centralizing property which is an important feature of string insulation.

20 A further point in connection with the present method of string insulation is that the output of the machine is generally limited by the speed of the string serving head.

25 An object of the present invention is to provide an air-spaced string insulated conductor in which the conducting core is truly centrally located with respect to the insulating tube or envelope.

30 Another object of the invention is to provide an air-spaced string insulated conductor in which the conducting core is not deformed by the pull of the string during the wrapping operation.

35 A further object of the invention is to enable an increase in speed of operation of the insulating machine which consequently increases the output and reduces the cost of the insulating operation.

40 In accordance with the invention the above mentioned defects are obviated by applying two or more separate evenly spaced strings to the conductor. According to one feature of the invention two such strings are used, which are so arranged around the core that one falls exactly mid-way between the adjacent turns of the other. Therefore, at any section of the conductor there will be strings diametrically opposite one another with the result that any possibility for the wire to spiral is avoided and better centralization of the conductor is attained.

50 According to another feature of the invention, three or more evenly spaced strings are used.

55 An advantage of the invention is that, by applying two or more separate evenly spaced strings to the conductor, the speed of the string serving head is correspondingly reduced with respect to

Fig. 3 shows diagrammatically a string head suitable for applying two strings in accordance with this invention. The core 1 which is to be wrapped with strings 3 and 4 passes through a hollow spindle 9 on which is mounted the string bobbin carrier consisting of a circular base 10 to which is fixed a cylindrical cover 11 protecting the string bobbin 12. The bobbin 12 is supported on the spindle and the usual drag washers 13 are provided. The bobbin 12 is wound with two strings 3 and 4. On one side of the cylindrical portion 11 of the bobbin carrier are two sets of guide holes 14, 15 and 16, 17 through which the strings 3 and 4 are laced. These holes 14, 15 and 16, 17 serve to guide the strings to the guide 18. As shown in Fig. 4 the guide 18 consists of a tubular member which is mounted on the spindle of the bobbin carrier, and has a bore 21 which is in continuation of the bore of the spindle 9. At one extremity of the guide are two eyes 19 and 20 through which the strings 3 and 4 pass to be applied to the core. The distance between the eyes 19 and 20 is such that the strings 3 and 4 passing through them are applied to the core 1 so that one string falls exactly mid-way between the adjacent turns of the other string. The internal bore of the guide 18 is large enough to allow convenient passage of the wire 1 and has a very smooth surface so as to offer practically no resistance to such passage as the wire is pulled against the wall of the bore 21 by the pull of the strings 3 and 4. The eyes 19 and 20 are large enough to allow convenient passage of the strings 3 and 4 but small enough to offer very small leverage to the pull of the strings 3 and 4 on the core 1.

Fig. 5 shows an alternative construction of the string guide 18 in which the eyes 19 and 20 are placed diametrically opposite one another so that the strings 3 and 4 apply their pulling effect to the core at the same time and at the same point. In this case the tendency of the wire to bear against the bore 21 is greatly reduced.

The string head is driven in any convenient manner or as shown on Fig. 3.

Although the invention has been described with reference to a conductor covered with paper tape it is to be understood that this term is meant to cover all similar insulating coatings.

What is claimed is:

1. In a paper and air insulated conductor a light conducting strand, a wrapping of tape about said strand and means for centralizing said strand within said wrapping, said means compris-

ing a first spacer string wound upon said conductor in a helix of large pitch and in continuous contact therewith and a second spacer string helically wound between the turns of said helix to leave a wide air space between said strings and to oppose effectively the bending effect on the conductor by said first string.

2. A light conducting core, a plurality of spacing strings wound in helical turns about said core so that at any point on the core the strings are separated by wide, substantially equal air spaces and so that the bending force on said core resulting from tension in any one string is counteracted by the opposing force resulting from tension in another of said strings, and a layer of insulating material placed about said helical turns with a substantially uniform spacing from said core equal to the thickness of one of said strings.

3. A light conducting core, a pair of spacing strings wound in spaced relation about said core so that at any point on the conductor said strings are substantially diametrically opposite one another with respect to said core and the bending force on said core resulting from tension in one of said strings is counteracted by the opposing force resulting from tension in the other string and a layer of insulating material placed about said core and in uninterrupted contact with at least one of said wound strings.

4. A method of producing an insulated thin conductor which comprises winding a spacing string about the thin conducting strand in helical turns of large pitch, counteracting the distorting effect upon the strand due to said winding of the spacing string by winding at least one other string upon the conductor in continuous contact therewith and with helical turns parallel to those of the spacing string and spaced therefrom by wide air-gaps and applying an outer wrapping over the turns of said spacing strings.

5. A method of centering a thin conducting core within an insulating envelope which comprises wrapping a pair of spacing strings simultaneously about the core so that at any point on the core the tendency of one string to bend the core is counteracted by that of the other string and in placing the insulating envelope upon said wrapped strings the wrapping of said strings being such that they make uninterrupted contacts with said conductor and said envelope respectively.

WILLIAM KIRBY WESTON.

55

60

65

70

75

80

85

90

95

100

105

110

115

120

125

130

135

140

145

150