

(12) PATENT
(19) AUSTRALIAN PATENT OFFICE

(11) Application No. AU 200125371 B2
(10) Patent No. 774080

(54) Title
Chilling apparatus

(51)⁷ International Patent Classification(s)
F25D 031/00

(21) Application No: **200125371**

(22) Application Date: **2001.01.16**

(87) WIPO No: **WO01/53765**

(30) Priority Data

(31) Number	(32) Date	(33) Country
0001048	2000.01.17	GB

(43) Publication Date : **2001.07.31**

(43) Publication Journal Date : **2001.10.11**

(44) Accepted Journal Date : **2004.06.17**

(71) Applicant(s)
Chilled Concepts Limited; Brian Newman

(72) Inventor(s)
Brian Newman

(74) Agent/Attorney
SPRUSON and FERGUSON,GPO Box 3898,SYDNEY NSW 2001

AU 200125371

(12) INTERNATIONAL APPLICATION PUBLISHED UNDER THE PATENT COOPERATION TREATY (PCT)

(19) World Intellectual Property Organization
International Bureau



(43) International Publication Date
26 July 2001 (26.07.2001)

PCT

(10) International Publication Number
WO 01/53765 A1

- (51) International Patent Classification⁷: **F25D 31/00**
- (21) International Application Number: PCT/GB01/00160
- (22) International Filing Date: 16 January 2001 (16.01.2001)
- (25) Filing Language: English
- (26) Publication Language: English
- (30) Priority Data:
0001048.8 17 January 2000 (17.01.2000) GB
- (71) Applicant (for all designated States except US):
CHILLED CONCEPTS LIMITED [GB/GB]; Selecto House, Unit J Abbey Wharf Ind. Est., Kingsbridge Road, Barking, Essex IG11 0BD (GB).
- (71) Applicant and
(72) Inventor: **NEWMAN, Brian [GB/GB]**; New House, The Bridgeway, Selsey, Chichester, West Sussex PO20 0LQ (GB).
- (74) Agents: **WANT, Clifford, J. et al.**; Langner Parry, 52-54 High Holborn, London WC1V 6RR (GB).
- (81) Designated States (*national*): AE, AG, AL, AM, AT, AU, AZ, BA, BB, BG, BR, BY, BZ, CA, CH, CN, CR, CU, CZ, DE, DK, DM, DZ, EE, ES, FI, GB, GD, GE, GH, GM, HR, HU, ID, IL, IN, IS, JP, KE, KG, KP, KR, KZ, LC, LK, LR, LS, LT, LU, LV, MA, MD, MG, MK, MN, MW, MX, MZ, NO, NZ, PL, PT, RO, RU, SD, SE, SG, SI, SK, SL, TJ, TM, TR, TT, TZ, UA, UG, US, UZ, VN, YU, ZA, ZW.
- (84) Designated States (*regional*): ARIPO patent (GH, GM, KE, LS, MW, MZ, SD, SL, SZ, TZ, UG, ZW), Eurasian patent (AM, AZ, BY, KG, KZ, MD, RU, TJ, TM), European patent (AT, BE, CH, CY, DE, DK, ES, FI, FR, GB, GR, IE, IT, LU, MC, NL, PT, SE, TR), OAPI patent (BF, BJ, CF, CG, CI, CM, GA, GN, GW, ML, MR, NE, SN, TD, TG).
- Published:**
— with international search report
- For two-letter codes and other abbreviations, refer to the "Guidance Notes on Codes and Abbreviations" appearing at the beginning of each regular issue of the PCT Gazette.

(54) Title: CHILLING APPARATUS

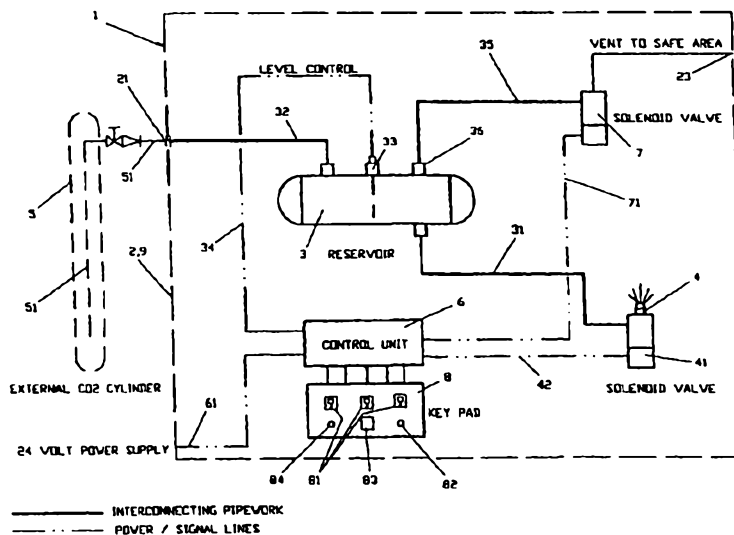

(57) Abstract: A chilling apparatus (1) for chilling drinking vessels (44) comprising a liquid gas reservoir (3) in fluid communication with a chilling nozzle (4) under the control of a valve (41) controlled by a control unit (6), so that the drinking vessel may be chilled by a metered quantity of liquid gas vapourising from the chilling nozzle. The reservoir is provided with a vent (36) to prevent a buildup of vapourised liquid gas in the pipework and/or reservoir.

WO 01/53765 A1

Chilling apparatus

This invention relates to chilling apparatus for chilling drinking vessels.

The use of vapourising liquid carbon dioxide for
5 chilling glass drinking vessels in order to serve
beverages therein at a preferred low temperature is
known. In known apparatus an inverted drinking vessel
is held over a nozzle connected to a carbon dioxide
cylinder and the liquid gas is allowed to vaporize in
10 the inverted glass, cooling the glass by absorbing
latent heat of vaporization. It is known for the nozzle
to be controlled by a simple timing device effectively
to provide a metered supply of vapour.

However, as a nozzle valve is open to emit vapour,
15 the pressure in a supply line from the cylinder to the
nozzle drops, causing small gas bubbles to form in the
supply line. When the nozzle is closed, some of the
bubbles may re-liquefy, but the majority collect and
eventually form a gas lock in the supply line, causing
20 the apparatus to malfunction. In order to mitigate this
problem, it has been necessary to keep the supply line
short and place the gas cylinder close to the nozzle.
This means the high pressure cylinder must be located
in a serving area in which the chilling apparatus is to
25 be used, which is inconvenient and potentially
hazardous.

Known apparatus has lacked safety systems and the
controls have been difficult to use.

It is an object of the invention to mitigate these disadvantages.

According to the invention there is provided a chilling apparatus for chilling a drinking vessel, the apparatus comprising a reservoir for liquefied gas, the reservoir being in fluid communication by pipework with a chilling nozzle under the control of metering means, such that the drinking vessel may be chilled by a metered quantity of the liquefied gas vapourising from the chilling nozzle, wherein the reservoir is provided with venting means to prevent a build up of vapour from the liquefied gas in the pipework and/or reservoir.

Conveniently, the liquid gas reservoir is connectable to a remote liquid gas source for maintaining a supply of the liquid gas to the reservoir.

Advantageously, the venting means includes first valve means, and the reservoir is provided with level sensing means to provide a signal to control means to open the first valve means to vent the reservoir when a level of liquid gas in the reservoir is below a predetermined minimum level and to close the valve when the level of liquid is at or above a predetermined maximum level.

Conveniently, the control means includes timing means and is adapted to close the first valve means after a predetermined time from opening the first valve means if the level of liquid gas has not reached the predetermined maximum level.

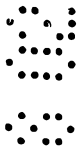

Advantageously, the control means is arranged to provide a warning signal and/or shut down the apparatus when after opening the first valve means the level of liquid does not reach the predetermined maximum level within the predetermined time, or is arranged to monitor the level sensing means and to close the first and second valve means and shut down the apparatus on detecting a malfunction of the level sensing means.

Conveniently, the metering means includes second valve means for controlling emission of vapourising liquid gas fro the chilling nozzle controlled by chilling timing means.

Advantageously, the chilling means provides a plurality of predetermined emission times for chilling drinking vessels of different sizes.

Preferably, one of the plurality of different predetermined emission times may be selected by operating one of a plurality of push buttons respectively.

Advantageously, the control means includes interlocking means to prevent the first valve means and the second valve means being open at the same time.

Conveniently, the chilling nozzle is provided with a seat for locating an inverted drinking vessel to be chilled over the chilling nozzle.

Preferably, the seat is provided with sufficient passages communicating between the inside and outside of an upturned drinking vessel to vent vapour emitted by the chilling nozzle into the drinking vessel to the outside of the drinking vessel, for the drinking vessel not to be forced from the seat by the emitted vapour.

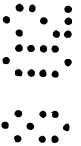
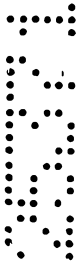

Conveniently, the apparatus is at least partially located in a housing and hood means.

Conveniently, the housing is adapted for fixing to counter means.

Advantageously, the hood means is adapted to prevent a head of a user being
5 placed close enough to the chilling nozzle to be discomforted or injured by the emission of vapour therefrom.

Conveniently, the apparatus is adapted to use carbon dioxide as the liquid gas.

The invention provides the advantage that a high pressure cylinder supplying the
10 apparatus may be located remote from the apparatus. This is more convenient and less hazardous than arrangements used in the prior art. In addition, it means that changing of cylinders may be conveniently carried out by skilled staff, such as cellarmen, rather than by bar staff.

A preferred embodiment of the invention provides the additional advantage that
15 a drinking vessel to be cooled may be located on a seat to be chilled and does not have to be held down over the nozzle as in the prior art.

In another preferred embodiment, the apparatus is provided with a plurality of push-buttons by which

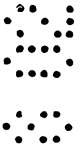
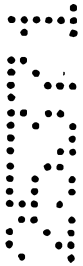

different pre-set chilling times for different size drinking vessels or degrees of cooling may be selected.

Further preferred embodiments provide the advantage that the apparatus will shut down safely when
5 the gas cylinder is empty or in the event of certain malfunctions.

The invention will now be described by way of example and with reference to the accompanying drawings in which:

10 Figure 1 is a schematic drawing of a chilling apparatus in accordance with the invention;

Figure 2 is a perspective view of the apparatus of Figure 1;

15 Figure 3 is a plan view of a seat of the apparatus of figure 2 for holding an inverted drinking vessel;

Figure 4 is a cross-sectional view along the line x-x of figure 3; and

20 Figure 5 is a schematic diagram of a control unit of the apparatus of Figure 1.

In the figures like reference numbers denote like parts.

As seen in the Figures, a chilling apparatus 1, located in a housing 2 and hood 9, comprises a high-pressure reservoir 3 connected by a supply line 31 to a chilling nozzle 4. The reservoir 3 is connected by a high-pressure pipe 32 to a connector 21 providing an inlet port on a wall 22 (see Figure 2) of the housing 2 for connection by high-pressure supply pipework 51 to a remote liquid gas cylinder 5. The high-pressure pipework 51 may run to, for example, a cellar via existing pipework routes. The connection of the pipework 51 to the cylinder 5 is so arranged that, even as a level of liquid in the cylinder 5 falls and gas accumulates therein, liquid rather than gas will be supplied from the cylinder 5 to the reservoir 3. This may be achieved by the provision of an internal dip pipe 510 inside the cylinder 5 so that liquid gas is drawn from the bottom of the cylinder.

The reservoir 3 is provided with a two-level level sensor 33, for example using thermistors, for sensing predetermined minimum and maximum levels of liquid in the reservoir 3, the sensor 33 being electrically connected by a first signal line 34 to a control unit 6. The reservoir 3 is also provided with a venting outlet 36 connected by a third pipe 35 to a first solenoid valve 7 and thence to a vent port 23 on the wall 22 of the housing 2. Provision may be made to lead venting gas away from the apparatus 1 by further pipework (not shown). The first solenoid valve 7 is also electrically connected by a second signal line 71 to the control unit 6.

Emission of vapour from the chilling nozzle 4 is controlled by a second solenoid valve 41 also electrically connected by a third signal line 42 to the control unit 6.

The control unit 6, which has a 24 volt electrical supply 61, is also electrically connected to a key pad 8 having three time control push buttons 81, a power switch 82, a stop button 83 and an "empty cylinder" warning light 84.

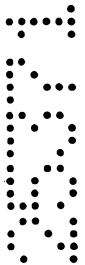

Referring to figure 2, the reservoir and solenoid valves are located in a housing 2 at a base of the chilling apparatus 1 in use and the key pad 8 is located on a hood 9 at the top of the apparatus 1 in use. The chilling nozzle 4 is located to protrude through a central aperture 46 in a cylindrical seat 45 recessed into an upper horizontal, in use, face 24 of the housing 2. As best seen in figures 3 and 4, the seat comprises a central recessed portion 47 surround by a concentric raised downwardly, outwardly sloping rim 48. The seat 45 is provided in its base with radial longitudinal slots 43.

The housing 2 is connected to the hood 9 by a vertical member 91 for housing electrical connections 42, 71, 34 between the control unit 6 housed in the hood 9 and the solenoids 41, 7 and the reservoir level sensor 33 located in the housing 2 respectively. A rear face of the vertical member 91 is provided with an orthogonal horizontal panel 92 for attachment of the apparatus 1 to, for example, a bar counter.

In use, a gas cylinder 5 is remotely connected by the supply pipework 51 to the connector 21 and thence to the reservoir 3 by the high pressure pipe 32. On first switching the apparatus 1 on, the level sensor 33 senses that a liquid level in the reservoir 3 is not at a predetermined maximum level and signals the control unit 6 which opens the first solenoid valve 7. The reservoir 3 is thus vented and fills with liquid gas from the supply cylinder 5 until the level sensor 33 senses that the level of liquid in the reservoir 3 has reached the predetermined maximum value. The sensor 33 then signals the control unit 6 which closes the first solenoid valve 7 so that pressure in the reservoir 3 rises substantially to the same pressure as in the supply cylinder 5.

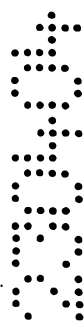
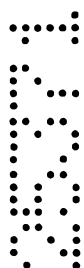

In order to chill a drinking glass 44, the glass
10 44 is inverted and located on the seat 45 with a bowl
of the glass covering the chilling nozzle 4. In this
position an edge of the bowl bridges the elongate slots
43 in the base of the seat 45. A push-button 81
appropriate to the size of glass 44, and/or the extent
15 of chilling required, is pushed by an operator.

On detecting that a push-button 81 has been pushed
the control unit 6 opens the second solenoid valve 41
for a corresponding predetermined time. Liquid gas
emerging from the nozzle 4 is de-pressurised and
20 immediately vaporizes, drawing latent heat of
vaporization from the immediate surroundings, including
the inverted glass 44. The emergent vapour fills the
bowl of the glass 44 and flows through the elongate
slots 43 and around the outside of the glass 44.

25 While the second solenoid valve 41 is open, gas
bubbles may form in the first pipe 31 from the
reservoir and in the reservoir 3 itself. On the re-
pressurising of the reservoir 3 and first pipe 31 as
the second solenoid 41 is closed, some of these bubbles
30 may be re-liquefied, but the pipework 31 and reservoir
3 are so designed that any remaining bubbles tend to

collect in the top of the reservoir 3. After repeated use, this collected gas will force down the level of liquid in the reservoir 3 until the level sensor 33 will sense that the level is below the predetermined
5 minimum level. The control unit 6 will then open the first solenoid valve 7 to vent the reservoir 3 until liquified gas entering the apparatus 1 from the supply cylinder 5 raises the level in the reservoir 3 to the predetermined maximum level. It will be understood that
10 the entry of the supply line 32 into the reservoir is preferably so arranged that gas bubbles will not collect in the supply line 32, although any so collected will tend to be swept into the reservoir 3 by the incoming liquefied gas.

15 Referring to Figure 5, the control unit 6 is also provided with an interlock system 62 to prevent the first and second solenoids 7, 41 being open at the same time.

The control unit 6 is further provided with a
20 timing mechanism incorporated in a microprocessor 63 so that when the level sensor 33 does not signal that the level in the reservoir 3 has reached the predetermined level within a predetermined venting time after the first venting solenoid 7 is opened, the warning light
25 84 on the key pad 8 is lit by the control unit to indicate that the supply cylinder 5 needs changing and the control unit signals both the solenoid valves 7, 41 to close.

The control unit 6 is also provided with
30 monitoring means 64, known per se, for monitoring the level sensor 33 and for closing down the apparatus 1 if

a malfunction is detected. A manual stop button 83 is also provided on the control pad 8 for closing down the apparatus. The microprocessor 63 also incorporates known self-test and diagnostics facilities to aid
5 trouble-shooting by service engineers.

As can be seen from Figure 2, the hood 9 is so designed to overhang the chilling nozzle 4, so that an operator cannot place his or her head close to the chilling nozzle 4 and thereby suffer discomfort or
10 injury.

The claims defining the invention are as follows:

1. A chilling apparatus for chilling a drinking vessel, the apparatus comprising a reservoir for liquefied gas, the reservoir being in fluid communication by pipework with a chilling nozzle under the control of metering means, such that the drinking vessel may be chilled by a metered quantity of the liquefied gas vapourising from the chilling nozzle, wherein the reservoir is provided with venting means to prevent a build up of vapour from the liquefied gas in the pipework and/or reservoir.
2. A chilling apparatus as claimed in claim 1, wherein the reservoir is connected to a remote liquefied gas source for maintaining a supply of the liquefied gas to the reservoir.
3. A chilling apparatus as claimed in claim 1 or claim 2, wherein the venting means includes first valve means, and the reservoir is provided with level sensing means to provide a signal to control means to open the first valve means to vent the reservoir when a level of liquefied gas in the reservoir is below a predetermined minimum level and to close the first valve means when the level of liquid is at or above a predetermined maximum level.
4. A chilling apparatus as claimed in claim 3, wherein the control means includes timing means and is arranged to close the first valve means after a predetermined time from opening the first valve means if the level of liquid has not reached the predetermined maximum level.
5. A chilling apparatus as claimed in claim 3 or claim 4, wherein the control means is arranged to provide a warning signal and/or shut down the apparatus when after opening the first valve means the level of liquid does not reach the predetermined maximum level within the predetermined time, or is arranged to monitor the level sensing means and to close the first and

second valve means and shut down the apparatus on detecting a malfunction of the level sensing means.

5 6. A chilling apparatus as claimed in any of the preceding claims, wherein the metering means includes second valve means for controlling emission of vapourising liquefied gas from the chilling nozzle controlled by chilling timing means.

10 7. A chilling apparatus as claimed in claim 6, wherein the chilling timing means provides a plurality of predetermined emission times for chilling drinking vessels of different sizes.

15 8. A chilling apparatus as claimed in claim 7, wherein a predetermined emission time is selectable by operating a push button.

9. A chilling apparatus as claimed in any of claims 6 to 8, wherein the control means includes interlocking means to prevent the first valve means and the second valve means being open at the same time.

20 10. A chilling apparatus as claimed in any of the preceding claims wherein the chilling nozzle is provided with a seat for locating an inverted drinking vessel to be chilled over the chilling nozzle.

25 11. A chilling apparatus as claimed in claim 10, wherein the seat is provided with passages communicating between the inside and outside of an upturned drinking vessel located on the seat to vent vapour emitted by the chilling nozzle into the drinking vessel to the outside of the drinking vessel.

30 12. A chilling apparatus as claimed in any of the preceding claims, wherein the apparatus is at least partially located in a housing adapted for fixing to support means such as a counter.

13. A chilling apparatus according to any preceding claim wherein the chilling nozzle is directed upwardly and a protective hood extends over the upturned base of the drinking vessel in use.

5

14. A chilling apparatus as claimed in any of the preceding claims which utilises carbon dioxide as the liquefied gas.

15. A chilling apparatus substantially as described hereinabove with
10 reference to Figures 1 to 5 of the accompanying drawings.

Dated 15 August, 2002
Chilled concepts Limited
Brian Newman

Patent Attorneys for the Applicant/Nominated Person
SPRUSON & FERGUSON

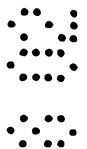
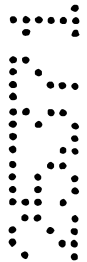

2004 2571

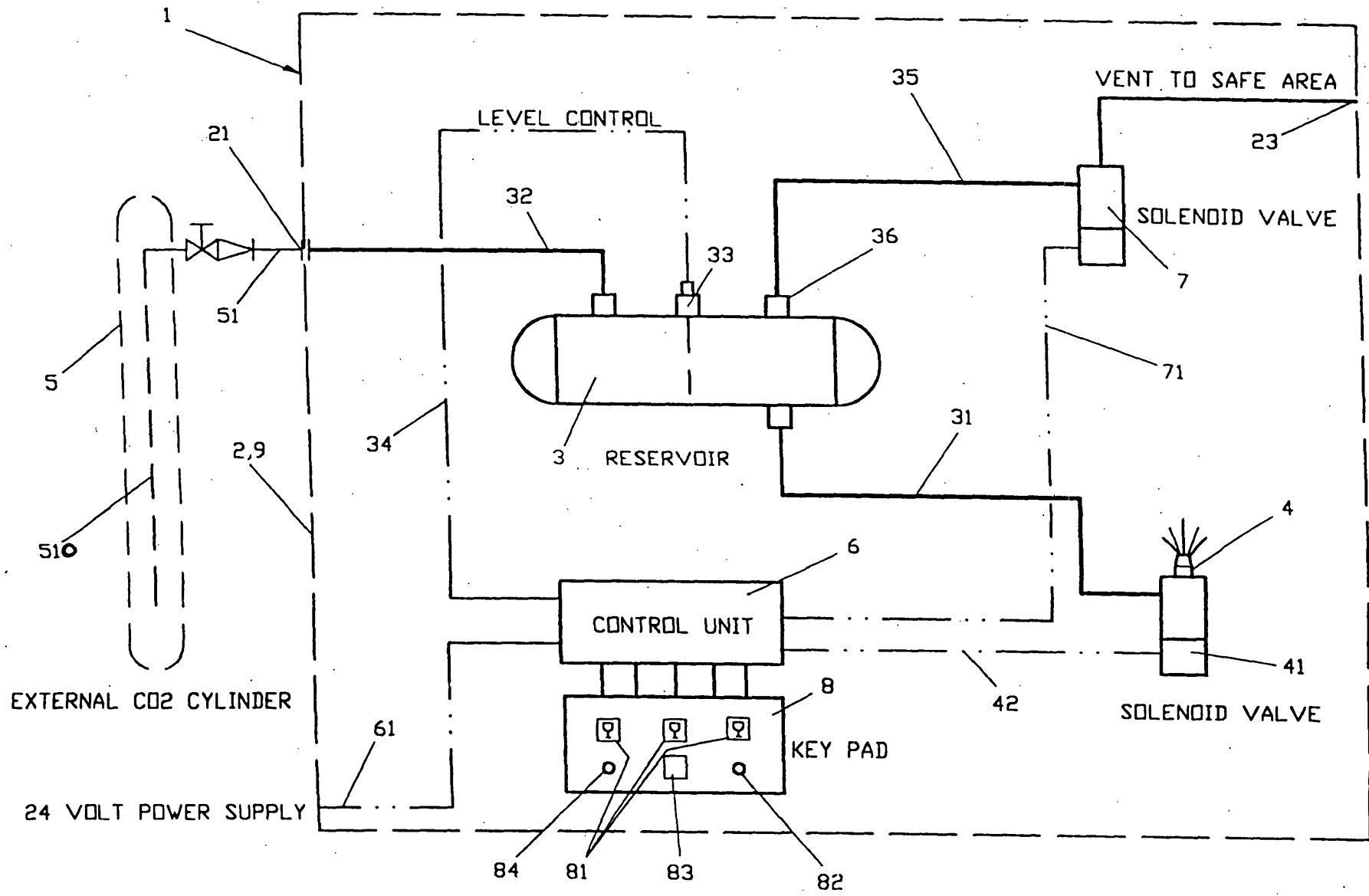

1/4

———— INTERCONNECTING PIPEWORK
- - - - - POWER / SIGNAL LINES

FIG 1

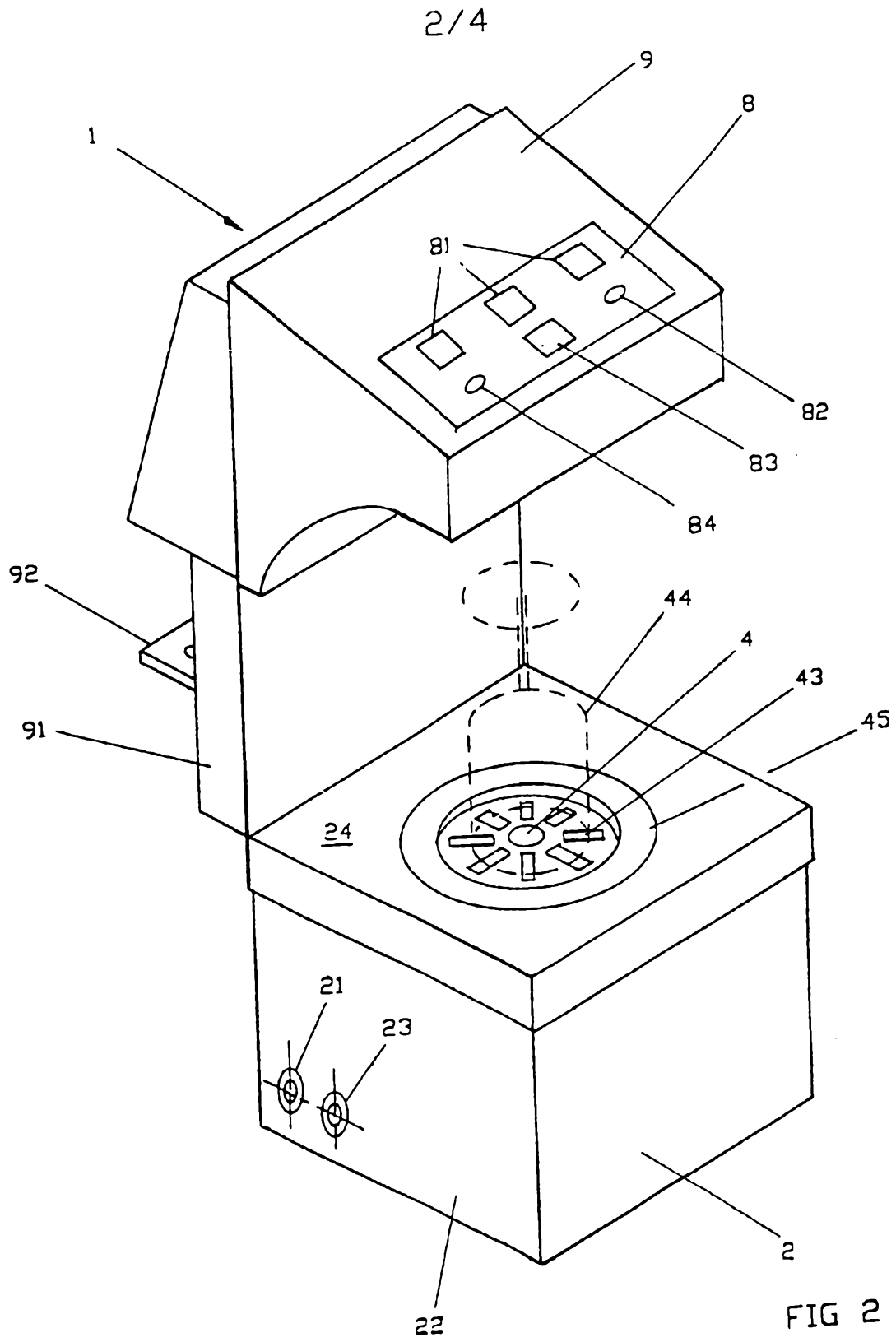

SUBSTITUTE SHEET (RULE 26)

3/4

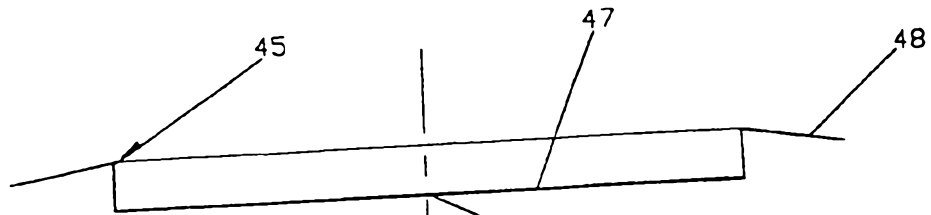

FIG 4

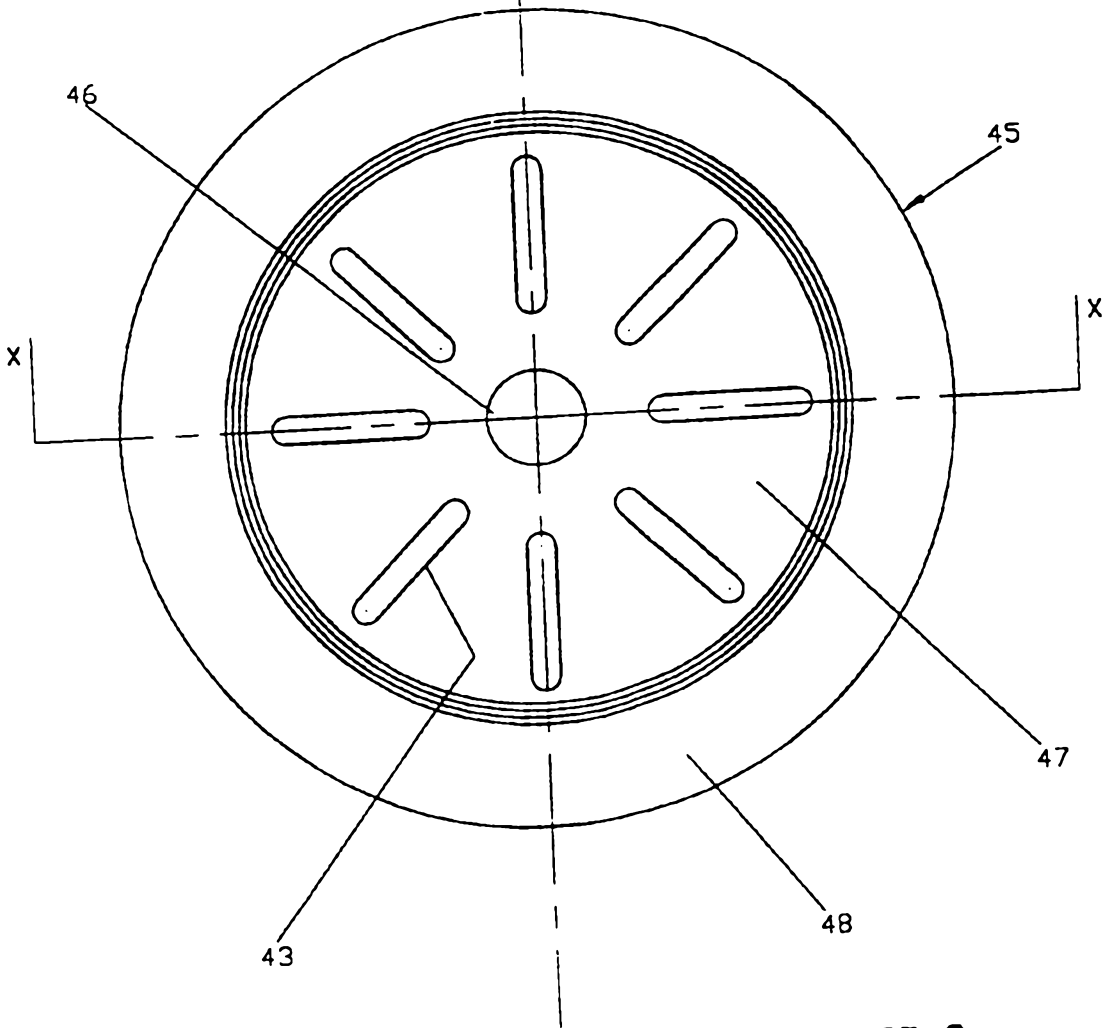

FIG 3

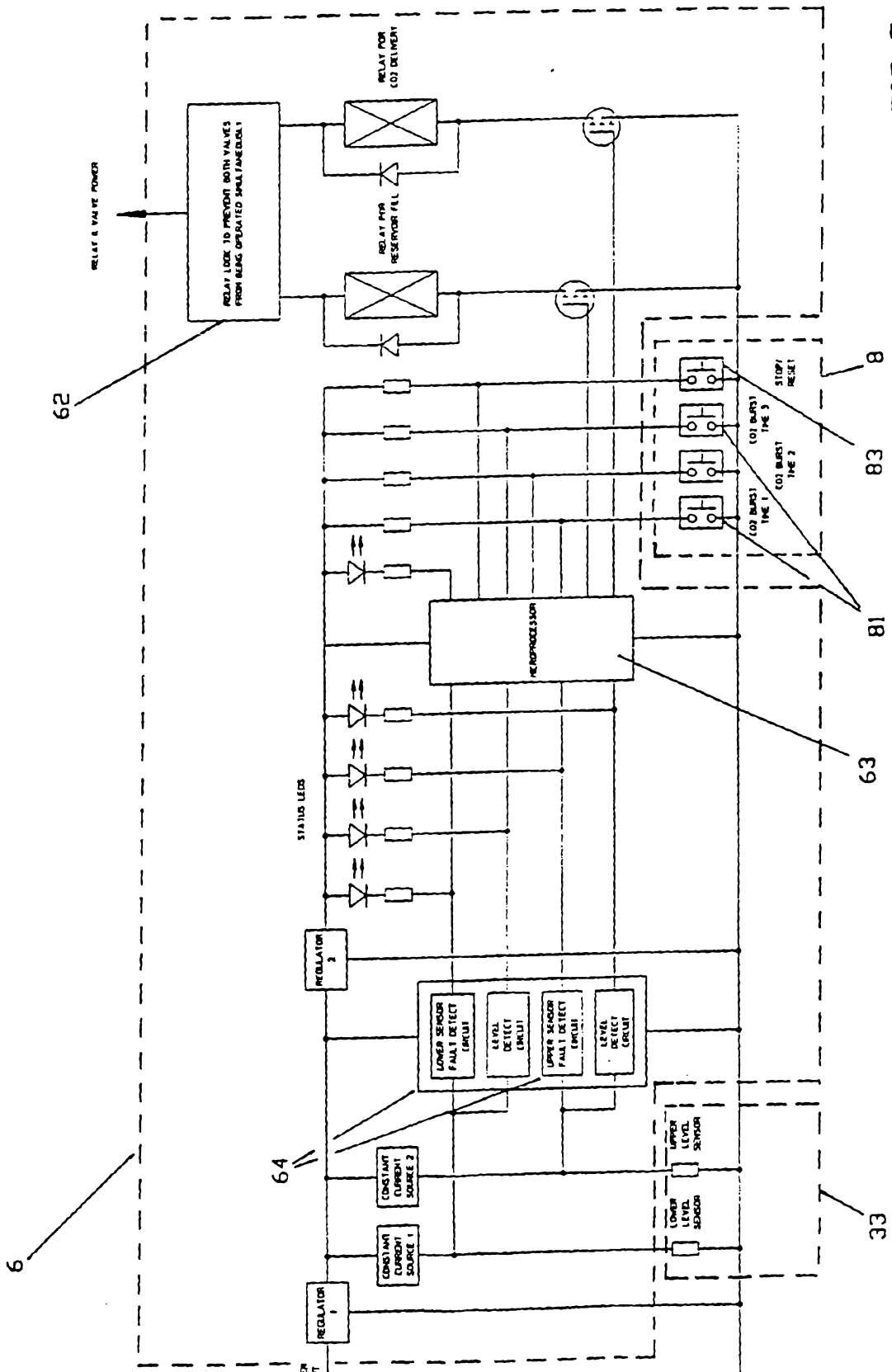

FIG 5