



## INTERNATIONAL APPLICATION PUBLISHED UNDER THE PATENT COOPERATION TREATY (PCT)

|   |                  |   |
|---|------------------|---|
| <p>(51) International Patent Classification<sup>6</sup> :<br/><b>B65D 33/01, 81/00</b></p>  | <p><b>A1</b></p> | <p>(11) International Publication Number: <b>WO 99/05036</b></p> <p>(43) International Publication Date: 4 February 1999 (04.02.99)</p>   |
| <p>(21) International Application Number: PCT/GB98/02246</p> <p>(22) International Filing Date: 28 July 1998 (28.07.98)</p> <p>(30) Priority Data:<br/>9715921.4 28 July 1997 (28.07.97) GB</p> <p>(71) Applicant (for all designated States except US): MARS U.K. LIMITED [GB/GB]; 3D Dundee Road, Slough SL1 4LG (GB).</p> <p>(72) Inventors; and<br/>(75) Inventors/Applicants (for US only): CHANDLER, Kevin, Paul [GB/GB]; 2 Berewyk Close, Hatfh Warren, Basingstoke, Hants RG24 8NU (GB). RICHICHI, Umberto [IT/GB]; 14 Mildmay Court, Odiham, Hants RG24 1AX (GB).</p> <p>(74) Agent: COLGAN, Stephen, James; Carpmaels &amp; Ransford, 43 Bloomsbury Square, London WC1A 2RA (GB).</p> |                  | <p>(81) Designated States: JP, US, European patent (AT, BE, CH, CY, DE, DK, ES, FI, FR, GB, GR, IE, IT, LU, MC, NL, PT, SE).</p> <p><b>Published</b><br/><i>With international search report.</i></p> |
| <p>(54) Title: BEVERAGE-PRODUCING PACKAGES</p>  |                  |   |
| <p>(57) Abstract</p>  |                  |   |
| <p>A beverage-producing sachet (2) containing, for example, chocolate powder consists of two laminates (4, 6) bonded at their edges (8) and having a bottom seam (10) including a reinforcing plastics strip (12) sandwiched between the laminates. Strip (12) is heat bonded to both laminates except in an openable portion (16) where it is heat bonded to one laminate and bonded by pressure-sensitive adhesive to the other laminate. Upon introduction of pressurised hot water through nozzle (20), the openable portion (16) peels open to release a hot chocolate beverage. The presence of the strip (12) provides a more predictable opening.</p>                                   |                  |   |

**FOR THE PURPOSES OF INFORMATION ONLY**

Codes used to identify States party to the PCT on the front pages of pamphlets publishing international applications under the PCT.

|    |                          |    |  |    |  |    |                          |
|----|--------------------------|----|--|----|--|----|--------------------------|
| AL | Albania                  | ES | Spain                                    | LS | Lesotho                                      | SI | Slovenia                 |
| AM | Armenia                  | FI | Finland                                  | LT | Lithuania                                    | SK | Slovakia                 |
| AT | Austria                  | FR | France                                   | LU | Luxembourg                                   | SN | Senegal                  |
| AU | Australia                | GA | Gabon                                    | LV | Latvia                                       | SZ | Swaziland                |
| AZ | Azerbaijan               | GB | United Kingdom                           | MC | Monaco                                       | TD | Chad                     |
| BA | Bosnia and Herzegovina   | GE | Georgia                                  | MD | Republic of Moldova                          | TG | Togo                     |
| BB | Barbados                 | GH | Ghana                                    | MG | Madagascar                                   | TJ | Tajikistan               |
| BE | Belgium                  | GN | Guinea                                   | MK | The former Yugoslav<br>Republic of Macedonia | TM | Turkmenistan             |
| BF | Burkina Faso             | GR | Greece                                   | ML | Mali   | TR | Turkey                   |
| BG | Bulgaria                 | HU | Hungary                                  | MN | Mongolia                                     | TT | Trinidad and Tobago      |
| BJ | Benin                    | IE | Ireland                                  | MR | Mauritania                                   | UA | Ukraine                  |
| BR | Brazil                   | IL | Israel                                   | MW | Malawi                                       | UG | Uganda                   |
| BY | Belarus                  | IS | Iceland                                  | MX | Mexico                                       | US | United States of America |
| CA | Canada                   | IT | Italy                                    | NE | Niger  | UZ | Uzbekistan               |
| CF | Central African Republic | JP | Japan                                    | NL | Netherlands                                  | VN | Viet Nam                 |
| CG | Congo                    | KE | Kenya                                    | NO | Norway                                       | YU | Yugoslavia               |
| CH | Switzerland              | KG | Kyrgyzstan                               | NZ | New Zealand                                  | ZW | Zimbabwe                 |
| CI | Côte d'Ivoire            | KP | Democratic People's<br>Republic of Korea | PL | Poland                                       |    |                          |
| CM | Cameroon                 | KR | Republic of Korea                        | PT | Portugal                                     |    |                          |
| CN | China                    | KZ | Kazakistan                               | RO | Romania                                      |    |                          |
| CU | Cuba                     | LC | Saint Lucia                              | RU | Russian Federation                           |    |                          |
| CZ | Czech Republic           | LI | Liechtenstein                            | SD | Sudan  |    |                          |
| DE | Germany                  | LK | Sri Lanka                                | SE | Sweden                                       |    |                          |
| DK | Denmark                  | LR | Liberia                                  | SG | Singapore                                    |    |                          |
| EE | Estonia                  |    |  |    |  |    |                          |

BEVERAGE-PRODUCING PACKAGES

The present invention relates to beverage dispensing and in particular to packages which provide, from a dispensing machine, a beverage when mixed with water provided from the machine.

5 Prior art beverage dispensing systems which utilise packages of beverage-producing material used in association with a complementary hot water providing machine are well know. In one variation of such known systems, the machine includes a reservoir of hot water communicating with a water injector in the form of a hollow needle. The beverage-producing packages consist of generally planar sachets. The user inserts such a  
10 sachet into the machine, and the injector of the latter pierces a plastics nozzle carried in the top seam of the sachet. Hot water under pressure is introduced into the sachet. The beverage is dispensed through the bottom of the sachet. The base seam of the latter is secured by a pressure-sensitive adhesive and is forced open under the pressure of fluid in the sachet. The beverage itself is formed by the hot water mixing with the beverage-  
15 producing material held in the sachet. Such a system has been commercially marketed by us under the Registered Trade Mark "Flavia". The sachets are described, for example, in EP-B-0179641 and the machines in GB-B-2122881.

With ground coffee or leaf tea a sheet of filter material is held within the sachet to support such coffee or tea. When the bottom of the sachet opens due to the pressure of  
20 hot water, the tea leaves or coffee grains remain in the sachet, supported by the filter material. By arranging the filter material to have an upward fold, this everts as the base seam of the sachet opens. The downward motion upon eversion assists in providing a predictably even and downwardly-directed opening, so that the beverage streams downwardly into the waiting receptacle, such as a cup or mug, and is not directed  
25 sideways so as to create a mess.

Problems have arisen with, in some instances, the sachet bottom seam opening too vigorously and explosively. This problem can be alleviated by heating the base seam, e.g. with hot air or steam, when the sachet is being opened: see EP-B-0426478.

The dispensing of beverages such as instant drinks or hot chocolate do not require  
30 a filter material in the sachet and have their own problems. Taking hot chocolate as an

example, this is simply held in the sachet and is forced out into the receptacle with the hot water. There are three criteria one hopes to achieve: cleanout (where all the chocolate powder is washed out of the sachet), dispersion (where all the powder is successfully dispersed with the hot water in the receptacle), and clean dispensing (all of the powder and liquid dropping cleanly into the receptacle). With the Flavia sachets, one can achieve any two of these three criteria easily, but to achieve all three all of the time is difficult.

The reason for this difficulty is the lack of predictability in the opening of the base seam, particularly in the absence of a filter material - as with hot chocolate. The moment a small section of the base seam opens, chocolate powder is sprayed through the opening with hot water and the pressure within the sachet rapidly falls. Thereafter, the base seam may or may not open to a greater degree and can pucker and twist. This can cause any one of the three above criteria not being achieved.

The present invention is concerned with a solution to this problem.

According to the present invention there is provided a generally-planar sachet as specified in the claims hereinafter.

The invention employs at least one reinforcing flexible strip in the base seam of the sachet extending across the portion that opens under the action of the pressurised water. It has been found that the presence of such a strip reduces puckering and twisting and the opening rapidly tends to form the shape, in cross-section, of an oval with tapered ends. Such an opening is downwardly directed and enables the three criteria mentioned above to be achieved more easily.

Preferably a single reinforcing strip of a plastics material is sandwiched between the two sheets of flexible material forming the sachet.

The material forming the sachet is preferably two face-to-face sheets of laminate, each having an outer plastics layer, an intermediate metal foil layer, and an inner plastics layer. The inner layers are heat bonded together around their edges to form the sachet, except in the region of the openable portion where the reinforcing strip is sandwiched between the two layers. The strip, which may be of the same plastics material as each inner layer, is heat bonded to one inner plastics layer. It is heat bonded to the other plastics layer except in the openable portion, where it is bonded with a pressure-sensitive

adhesive.

When the sachet is opened under the pressure of the water, the reinforced strip and one laminate forms one side of the opening and is relatively stiff. The other side is formed by the other laminate - to which it had been bonded with pressure-sensitive adhesive. By  
5 avoiding having just two very flexible laminates forming the sides of the opening, a more controlled opening may be formed of more even symmetry.

Although the invention is primarily designed for beverages such as hot chocolate, which does not dictate the need for a filter material in the sachet, the invention contemplates the possibility of its use with sachets containing filter material supporting,  
10 say, ground coffee or leaf tea.

A preferred embodiment of the invention will now be described, by way of example, with reference to the accompanying drawings in which:

Figure 1 is a front perspective view of a sachet according to the invention.

Figure 2 is a side cross-section of the lower portion of the sachet of Figure 1,  
15 along line A-A, and

Figure 3 is a perspective view of the openable portion of the sachet of Figures 1 and 2, after opening.

Referring to the drawings, the sachet 2 - which is designed to contain chocolate powder so as to provide a hot chocolate beverage - is formed of two face-to-face  
20 laminates 4,6. Each laminate consists of an outer polyester layer (12µm thickness), an intermediate aluminium layer (9µm) and an inner polypropylene layer (55µm). The laminates are heat bonded together, polypropylene to polypropylene at the edge 8 except at the bottom seam 10 where a strip 12 of polypropylene (150-300µm thickness) is sandwiched. The strip 12 is heat bonded to the polypropylene layer of one laminate, 4, at  
25 14 and is heat bonded to the polypropylene layer of the other laminate, 6, except in an openable portion 16. In this latter portion it is bonded by pressure-sensitive adhesive 18. In the top edge of the sachet is provided an openable nozzle 20 to receive a hollow needle water injector when a beverage is to be produced.

In operation, the sachet is inserted into a suitable dispensing machine, hot water  
30 under pressure is introduced into the sachet, and ultimately the pressurised water causes

4

the sachet to open in the openable portion 16. The reinforcing strip 12 and laminate 4 form one edge of the opening, whereas the laminate 6 forms the other edge of the opening. The openable portion tends to form the oval-shaped opening shown in Figure 3 with much more tendency and regularity than when the reinforcing strip 12 is omitted.

5

## Claims:

1. A generally-planar sachet having two face-to-face flexible sheets bonded around their edges to define the sachet with an inner volume containing a product which, when mixed with water, produces a beverage; the bonded edge including a base seam having a portion thereof adapted to open under pressure when pressurised water is introduced into the sachet and so release the beverage, the base seam including at least one flexible reinforcing strip attached to one or both flexible sheets extending across the openable portion.
2. A sachet according to claim 1 wherein each flexible sheet is a laminated material having an outer plastics layer, an intermediate metal foil layer, and an inner plastics layer.
3. A sachet according to claim 1 or 2 wherein a single flexible reinforcing strip is provided, permanently bonded to the inner face of one of the flexible sheets and bonded to a section of the inner face of the other of the flexible sheets with an adhesive which releases the bond under the pressure of the pressurised water so as to provide the openable portion.
4. A sachet according to any preceding claim wherein the, or each, reinforcing strip is of a plastics material.
5. A sachet according to any preceding claim including an openable nozzle bonded into the edge of the sachet to enable pressurised water to be introduced into the sachet.
6. A sachet according to any preceding claim wherein each flexible sheet is a laminate having an outer polyester layer, an intermediate aluminium layer and an inner polypropylene layer, the inner polypropylene layers being heat bonded together at said edges except in the region of the openable portion, there being juxtaposed between the laminates extending across the openable portion a polypropylene strip which is heat bonded to the polypropylene layer of one laminate, is heat bonded to the polypropylene layer of the other laminate except in the openable portion where it is bonded, to the polypropylene layer of the other laminate, with a pressure-sensitive adhesive.

1/1

FIG. 1

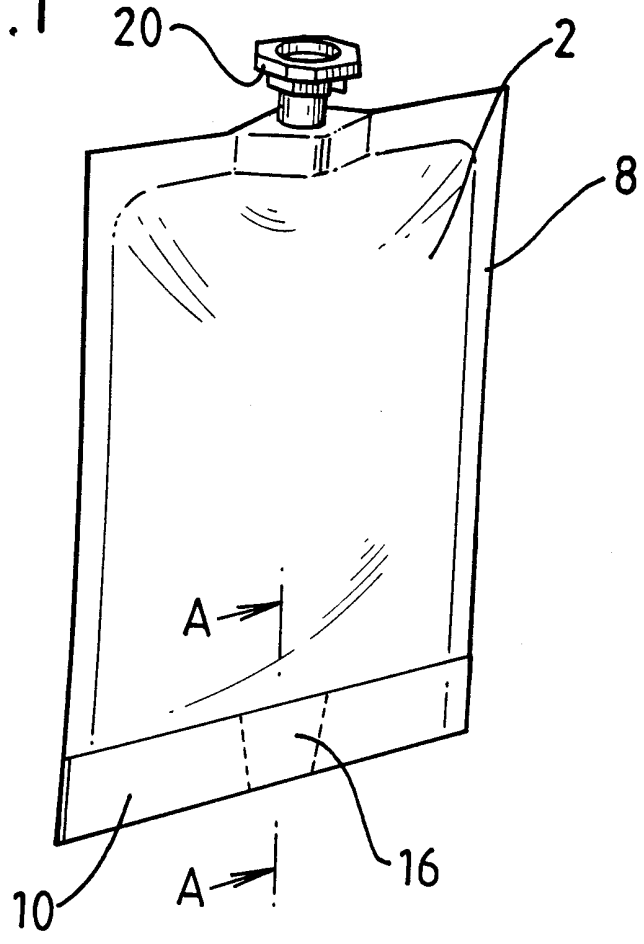

FIG. 3

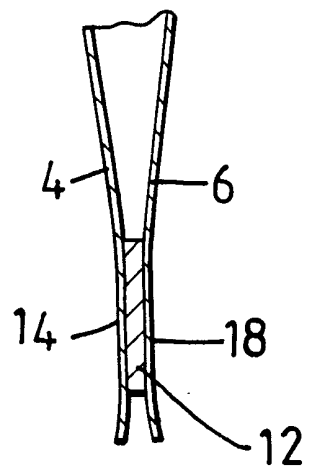
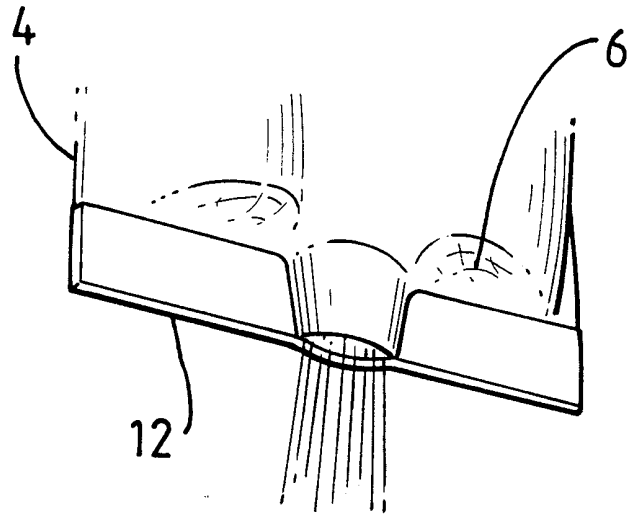

FIG. 2

# INTERNATIONAL SEARCH REPORT

International Application No

PCT/GB 98/02246

**A. CLASSIFICATION OF SUBJECT MATTER**  
 IPC 6 B65D33/01 B65D81/00

According to International Patent Classification (IPC) or to both national classification and IPC

**B. FIELDS SEARCHED**

Minimum documentation searched (classification system followed by classification symbols)

IPC 6 B65D

Documentation searched other than minimum documentation to the extent that such documents are included in the fields searched

Electronic data base consulted during the international search (name of data base and, where practical, search terms used)

**C. DOCUMENTS CONSIDERED TO BE RELEVANT**

| Category | Citation of document, with indication, where appropriate, of the relevant passages  | Relevant to claim No. |
|----------|---|-----------------------|
| Y        | EP 0 179 641 A (MARS G.B.) 30 April 1986<br>cited in the application<br>see page 5, line 3-34; figures 1-3<br>---               | 1-6                   |
| Y        | EP 0 541 093 A (TOYO ALUMINIUM KABUSHIKI<br>KAISHA) 12 May 1993<br>see page 3, line 10 - page 5, line 3;<br>figures 1-12<br>--- | 1-6                   |
| A        | EP 0 012 275 A (HOECHST) 25 June 1980<br>see page 3, line 15 - page 4, line 3;<br>figures 1-4<br>---                            | 1,2,4,5               |
| A        | EP 0 661 219 A (PACKS CO.) 5 July 1995<br>see column 6, line 57 - column 7, line 27;<br>figures 1-4<br>---                      | 1                     |
|          | -/--  |                       |

Further documents are listed in the continuation of box C.

Patent family members are listed in annex.

° Special categories of cited documents :

"A" document defining the general state of the art which is not considered to be of particular relevance

"E" earlier document but published on or after the international filing date

"L" document which may throw doubts on priority claim(s) or which is cited to establish the publication date of another citation or other special reason (as specified)

"O" document referring to an oral disclosure, use, exhibition or other means

"P" document published prior to the international filing date but later than the priority date claimed

"T" later document published after the international filing date or priority date and not in conflict with the application but cited to understand the principle or theory underlying the invention

"X" document of particular relevance; the claimed invention cannot be considered novel or cannot be considered to involve an inventive step when the document is taken alone

"Y" document of particular relevance; the claimed invention cannot be considered to involve an inventive step when the document is combined with one or more other such documents, such combination being obvious to a person skilled in the art.

"&" document member of the same patent family

Date of the actual completion of the international search

27 October 1998

Date of mailing of the international search report

04/11/1998

Name and mailing address of the ISA

European Patent Office, P.B. 5818 Patentlaan 2  
 NL - 2280 HV Rijswijk  
 Tel. (+31-70) 340-2040, Tx. 31 651 epo nl,  
 Fax: (+31-70) 340-3016

Authorized officer

Lenoir, C

# INTERNATIONAL SEARCH REPORT

International Application No  
PCT/GB 98/02246

| C.(Continuation) DOCUMENTS CONSIDERED TO BE RELEVANT |  |                       |
|--|--|-----------------------|
| Category   | Citation of document, with indication, where appropriate, of the relevant passages   | Relevant to claim No. |
| A  | FR 1 559 367 A (FISONS) 7 March 1969<br>see page 2, left-hand column, paragraph 2<br>see page 3, left-hand column, paragraph 11<br>- right-hand column, paragraph 5; figures<br>1-8<br><br>----- | 1,4                   |
| A  | US 4 899 911 A (MULTIMIX SYSTEMS)<br>13 February 1990<br>see column 8, line 33-53; figures 14-16<br><br>-----  | 1                     |

# INTERNATIONAL SEARCH REPORT

Information on patent family members

International Application No  
PCT/GB 98/02246

| Patent document<br>cited in search report | Publication<br>date | Patent family<br>member(s) | Publication<br>date |
|---|---------------------|----------------------------|---------------------|
| EP 179641      A                          | 30-04-1986          | AU 587584 B                | 24-08-1989          |
|   |                     | AU 4895085 A               | 01-05-1986          |
|   |                     | BR 8505234 A               | 29-07-1986          |
|   |                     | CA 1232234 A               | 02-02-1988          |
|   |                     | DK 484485 A,B,             | 24-04-1986          |
|   |                     | FI 853943 A,B              | 24-04-1986          |
|   |                     | JP 2668355 B               | 27-10-1997          |
|   |                     | JP 61142156 A              | 30-06-1986          |
|   |                     | US 4886674 A               | 12-12-1989          |
| EP 541093      A                          | 12-05-1993          | JP 5246442 A               | 24-09-1993          |
|   |                     | JP 2510807 B               | 26-06-1996          |
|   |                     | JP 6286757 A               | 11-10-1994          |
|   |                     | JP 6032359 A               | 08-02-1994          |
|   |                     | AT 149132 T                | 15-03-1997          |
|   |                     | CA 2082374 A               | 09-05-1993          |
|   |                     | DE 69217609 D              | 03-04-1997          |
|   |                     | DE 69217609 T              | 17-07-1997          |
|   |                     | US 5330269 A               | 19-07-1994          |
| EP 12275        A                         | 25-06-1980          | DE 2852877 A               | 19-06-1980          |
|   |                     | DK 519279 A                | 08-06-1980          |
| EP 661219      A                          | 05-07-1995          | JP 7187199 A               | 25-07-1995          |
|   |                     | JP 8011585 B               | 07-02-1996          |
|   |                     | JP 2574651 B               | 22-01-1997          |
|   |                     | JP 8085580 A               | 02-04-1996          |
|   |                     | JP 8119343 A               | 14-05-1996          |
|   |                     | US 5655842 A               | 12-08-1997          |
| FR 1559367    A                           | 07-03-1969          | BE 712901 A                | 31-07-1968          |
|   |                     | DE 1761016 A               | 11-03-1971          |
|   |                     | GB 1172803 A               | 03-12-1969          |
|   |                     | NL 6804466 A               | 01-10-1968          |
|   |                     | US 3473725 A               | 21-10-1969          |
| US 4899911    A                           | 13-02-1990          | AU 3987289 A               | 05-03-1990          |
|   |                     | CA 1333900 A               | 10-01-1995          |
|   |                     | JP 2045396 A               | 15-02-1990          |
|   |                     | WO 9001449 A               | 22-02-1990          |