

(21.)

JOHN GRAY.

Improvement in Machine for Laying Bridge Cables.

No. 122,247.

Patented Dec. 26, 1871.

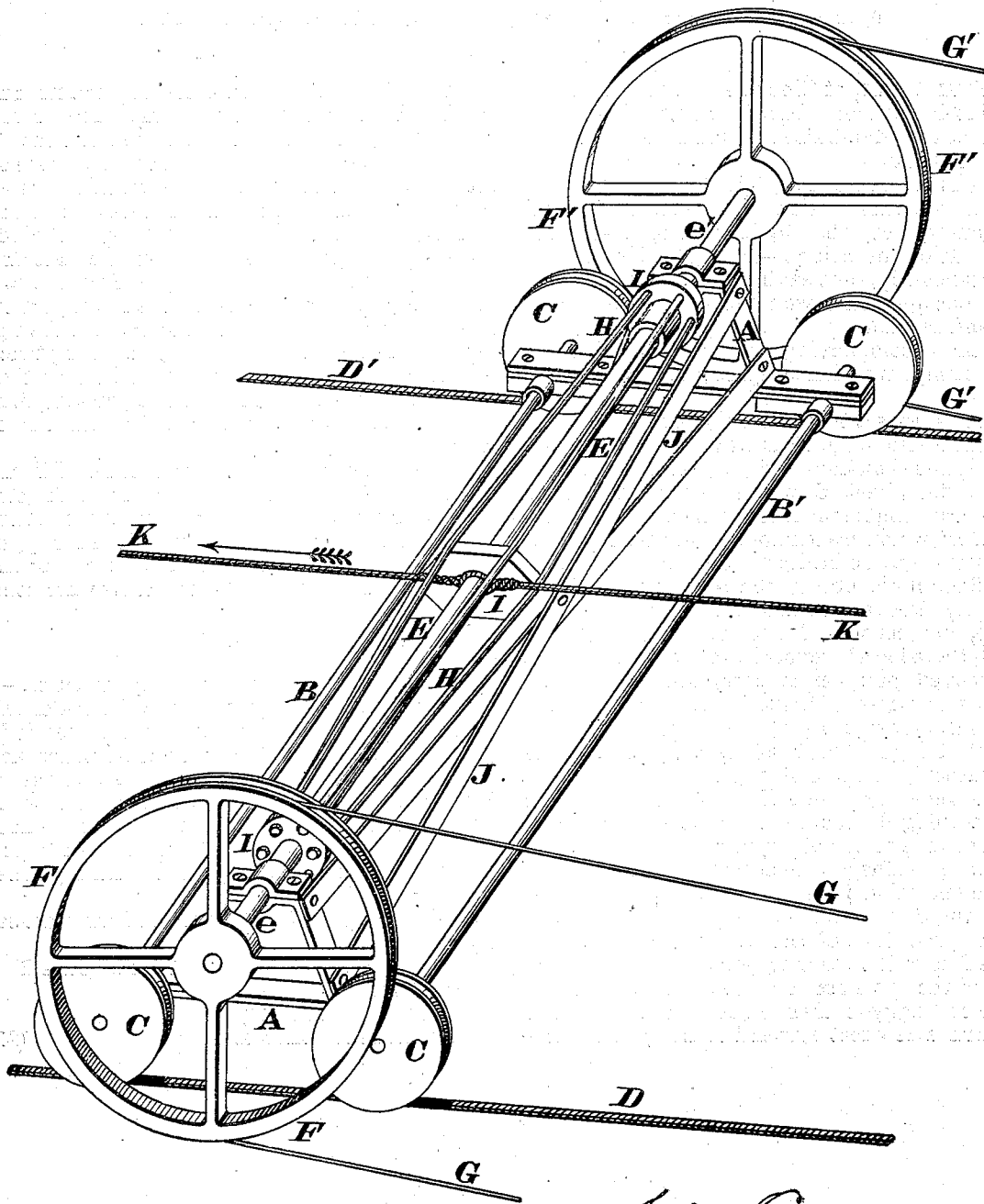

Attest.

*Geo. H. Layman*  
*John Kiloh*

*John Gray*  
INVENTOR.  
*By Knight Bros.*  
Attys.

# UNITED STATES PATENT OFFICE.

JOHN GRAY, OF CINCINNATI, OHIO.

## IMPROVEMENT IN MACHINES FOR LAYING BRIDGE-CABLES.

Specification forming part of Letters Patent No. 122,247, dated December 26, 1871.

I, JOHN GRAY, of Cincinnati, Hamilton county, Ohio, have invented a new and useful Machine for Laying Bridge-Cables, of which the following is a specification:

This is an improvement in devices for laying wire in the construction of wire-cables for suspension-bridges, whereby four strands—two for each side of the bridge—are enabled to be laid simultaneously, thus saving in time and producing at one operation two cables of precisely equal size and tension.

In the accompanying drawing a machine embodying my invention is represented by perspective view.

A represents a trunk or buggy-frame of suitable construction. B B' are two axles journaled in said frame and having rigidly attached to their extremities wheels C, whose V-grooves in their peripheries enable them to run along ropes or cables D D', which are temporarily stretched across the interval to be bridged. Journaled or otherwise fixed horizontally athwart the frame A is a shaft, E, whose extremities project outside of the frame, and consist of steel spindles *e e'*, upon which there loosely revolve two reels, F F', whose V-grooved peripheries carry the two double strands or wires G G' to be laid or stretched across the river or other interval which it is desired to bridge. The shaft E may, for the sake of lightness, be made of a gas-pipe, and may be strengthened by braces H and heads I. Braces J, extending diagonally and crosswise from one end of frame to the other, serve both to connect the end portions and to stiffen the frame.

The operation is as follows: To use this machine the wire is first run onto a large stationary drum. The ends of the two strands are then made fast to the starting point where the shore ends of the cable are to be connected. The machine or buggy is then placed upon the track and run a few feet forward of the point where

the ends of the strands are fastened; the strands are then doubled in a loop-form and put over and around the wheels F F' and dropped into the V-formed grooves of the same. An endless rope or cable, K, which engages around suitable drums or windlasses on either shore, is attached to the shaft E, and, being set in motion by the windlass on the opposite shore, draws the machine along its track, and in so doing pays out the two double strands simultaneously, the lower portion of each strand being the stationary and the upper portion the moving one, and traveling twice as fast as the buggy. It will thus be seen that each reel lays two strands at a time, making four strands laid down or stretched for each trip of the buggy.

As the buggy moves forward the reels F F' are made to revolve, taking the wire from the stationary drum and doubling it to the opposite shore, where it is taken off and placed in position. The buggy is then brought back for another trip, and so on until the cables are completed.

### Claim.

I claim herein as new and of my invention—

The wheeled machine or buggy for the simultaneous laying of two or more double strands in the construction of wire suspension-bridges, and consisting essentially of a frame, A, whose V-formed wheels C are adapted to travel on two or more temporary tracks or cables, and whose loosely-revolving reels F F' are adapted to pay out as many double strands, substantially as set forth.

In testimony of which invention I hereunto set my hand.

JOHN GRAY.

Witnesses:

GEO. H. KNIGHT,  
JAMES H. LAYMAN.

(21)