

INVENTOR

BY *Donald L. King*
Wood, Gibson & Crane
ATTORNEYS

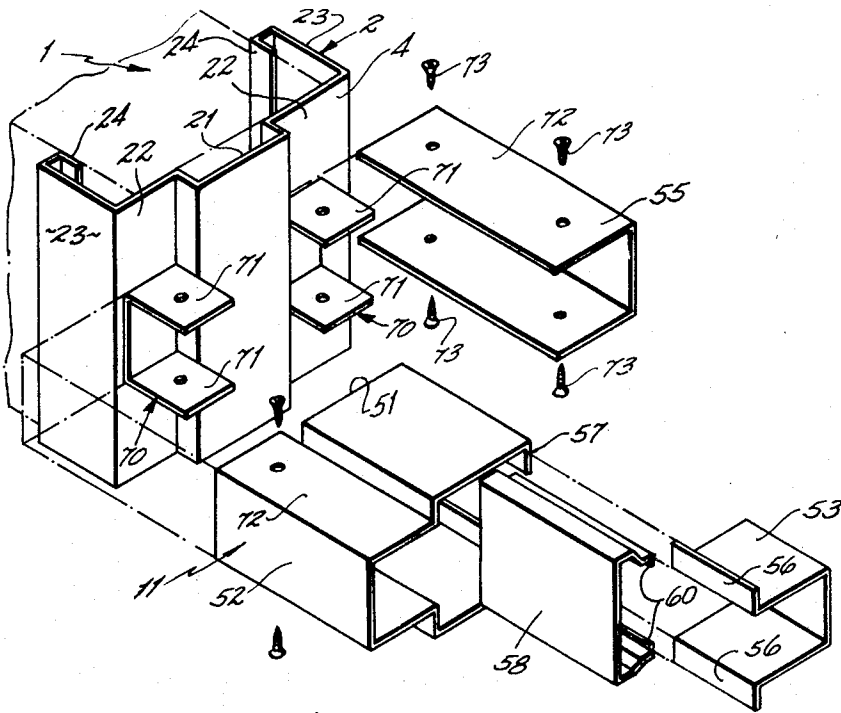

Fig. 8

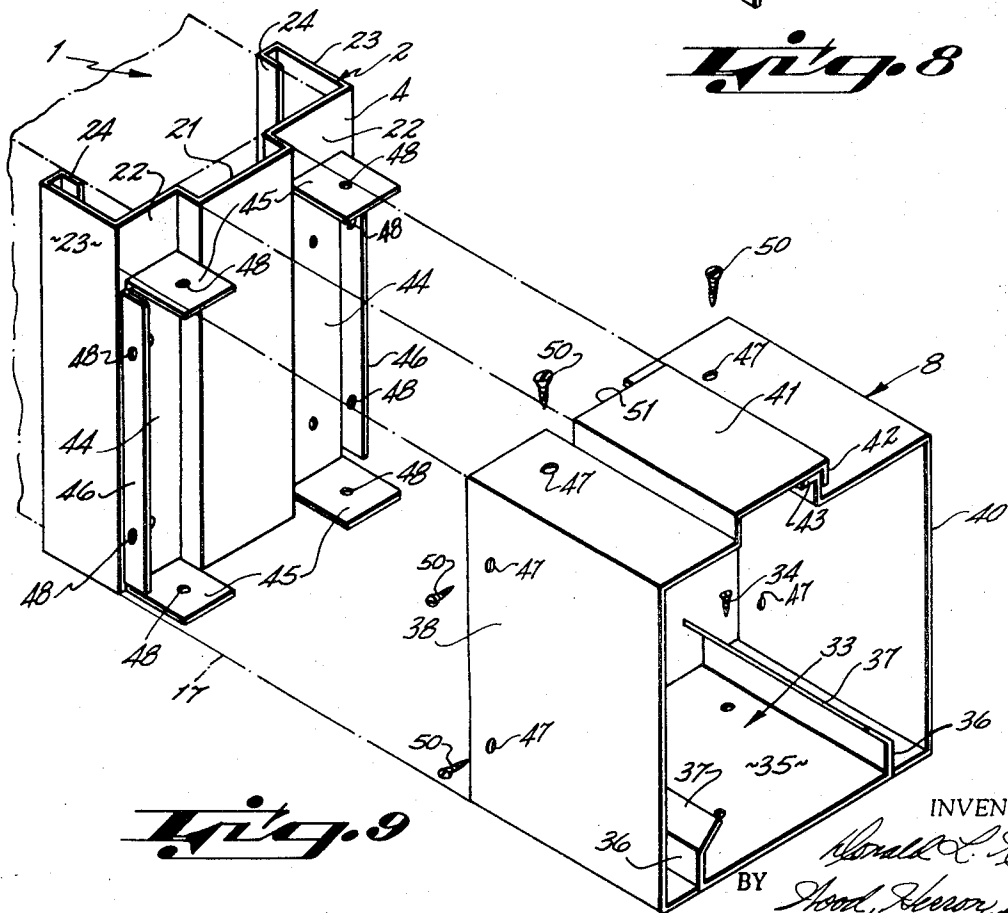

Fig. 9

INVENTOR.
Ronald C. King
BY *Howard, Heaver, & Evans*
ATTORNEYS

SECTIONAL SIDE LIGHT DOOR FRAME

Background of the Invention

This invention relates to sectional door frames formed of sheet metal and particularly to a frame, known in the art as a side light frame, consisting of a main frame which is installed within the door opening of a wall, combined with a secondary door frame consisting of vertical door jambs and a horizontal header mounted within the main frame, with transom and side light panels, formed of glass, extending between the main frame and the door frame.

One of the primary objectives of the invention has been to provide a frame formed of sheet metal sections supplied to the user in knocked-down condition for convenience and low cost transportation, to be erected in the field after the building walls have been erected.

The structure is intended particularly for installation in buildings in which the walls are of the so-called dry wall construction, that is, walls consisting of vertical studs and horizontal headers, with plasterboard panels on opposite sides, usually finished with a skim coat of plaster. The main frame, which fits into the prefabricated door opening, in the present example, consists of framing members formed of sheet metal, which are generally channel-shaped in cross section, with mitered corners joining the vertical framing members with the horizontal header. The mitered corners include corner clips which align and connect the members in flush and squared relationship.

Another objective of the invention has been to provide a convenient, simplified arrangement, whereby the secondary door frame, consisting of vertical door jambs and a horizontal header, is connected to the main frame, after the main frame has been installed within the door opening.

According to this concept, there is provided one or a pair of sills (depending on the selected design) which are secured rigidly to the floor of the building, the ends of which abut the lower end portions of the main frame after the main frame has been positioned within the door opening. The secondary or door frame is then installed with the lower ends of the vertical jambs resting upon the floor and anchored to the inner ends of the sills, thus completing the installation of the side light frame within the wall opening.

A further objective of the invention has been to provide means for connecting the several components of the frame together upon installation in the field in a rapid convenient manner without the use of special tools.

According to this aspect of the invention, the lower ends of the vertical framing members of the main frame, which are anchored to the wall, each include brackets having ears at their lower ends which interfit the sill, the end of each sill being secured to the ears of the main frame by means of screws of the sheet metal-type, passing through the end portion of the sill and through the ears of the anchor brackets. As noted earlier, the sills are anchored rigidly to the floor of the building.

In a similar manner, the vertical mullions or door jambs of the secondary frame, within which the doors are hung, also have their lower ends resting upon the floor and anchored to the inner ends of the sills by brackets and sheet metal screws passing through ears extending from the mullions into the sill.

The opposite ends of the transom bar, forming the header of the secondary door frame, are anchored to the main framing members by means of similar connecting brackets with the use of sheet metal screws. In addition, the frame structure includes vertical jamb extensions parallel with the door jambs and extending upwardly from the horizontal transom bar to the header of the main frame. The opposite ends of the jamb extensions are anchored in a similar manner by means of brackets and sheet metal screws, as described above. Description of the Drawings

In the drawings:

FIG. 1 is a general elevation illustrating the assembled side light door frame.

FIG. 2 is an enlarged sectional view taken along the line 2-2 of FIG. 1, detailing in cross section the configuration of the header of the main frame.

FIG. 3 is an enlarged sectional view taken along the line 3-3 of FIG. 1, detailing the composite header of the secondary frame.

FIG. 4 is an enlarged sectional view taken along the line 4-4 of FIG. 1 detailing the construction of one of the composite vertical door jambs of the secondary frame.

FIG. 5 is a sectional view taken along the line 5-5 of FIG. 1 detailing the construction of the sill of the side light frame and its anchorage with reference to the floor of a building.

FIG. 6 is a fragmentary cross-sectional view taken along the line 6-6 of FIG. 1, illustrating the composite construction of the framing members of the main frame and the secondary frame.

FIG. 7 is a fragmentary vertical sectional view taken along the line 7-7 of FIG. 1, further detailing the frame structure.

FIG. 8 is an exploded perspective view, as indicated by the broken circle in FIG. 1, illustrating one of the connectors by means of which the members of the frame are secured together. This arrangement is typical of the connecting means utilized throughout the structure.

FIG. 9 is a perspective view indicated by the broken circle at 9 in FIG. 1 illustrating one of the sill and base anchor connections, showing how the sill, in combination with the base anchor is connected to the main frame, or vertical jamb.

FIG. 10 is an exploded perspective of the frame structure, showing the method and assembly of the structure, as indicated by the circle identified at 10 in FIG. 1.

FIG. 11 is a general perspective view illustrating the construction of one of the corner clips (circle 11 of FIG. 1) by means of which the mitered corners of the main frame are joined together by a snap-in action upon assembly of the main frame within the wall opening.

SIDE LIGHT FRAME GENERALLY

The side light frame adapts itself to a number of design variations. For example, the framing members may be furnished to provide single or double side lights with a single or double door opening. In other instances, the unit may be furnished in single or multiple panels with no door opening (borrowed light). Still other combinations are available by virtue of the sectional construction which imparts design flexibility. The sectional side light frame assembly is intended particularly to be installed within an opening in a dry wall partition, that is, a wall constructed of vertical studs with plasterboard panel mounted on opposite sides of the studs. The dry wall is shown at 1 in FIG. 1 and, in a general way, in several other views.

The sectional side light frame selected to disclose the principles of the invention comprises a main frame 2, including a header 3 formed of sheet metal and generally U-shaped in cross section, arranged to embrace the marginal edge portions of the wall opening on opposite sides, as indicated diagrammatically in FIG. 7. The main frame is completed by a pair of vertical framing members 4 and 5. The framing members 4 and 5 are also formed of sheet metal and are identical in cross section to the header 3. The framing members 4 and 5, similar to the header 3, embrace the opposite marginal wall surfaces of the opening formed in the wall 1. The header 3 and the framing members 4 and 5 form the basic sectional frame structure which supports the remaining components or dividers of the side light frame, also of sectional construction and of composite design.

The mating ends of the header 3 and the upper ends of the vertical members 4 and 5 are mitered as at 6 (FIG. 1) to interfit one another upon assembly of the framing members within the wall opening. The mitered ends 6 are held in squared relationship with one another by corner clips indicated generally at 7 (FIG. 11) which provide a snap fit, rigidly connecting the members together at the corners. A corner clip of this nature

is disclosed in U.S. Pat. No. 3,222,833, issued to Harold L. Woodrum on Dec. 14, 1965, and assigned to the present assignee. A second form of corner clip construction, as shown in the copending application of Harold L. Woodrum, Ser. No. 801,033, also may be used at the corners as an alternate construction.

The vertical members 4 and 5 include adjustable jamb anchors (not shown), located near the upper ends of the Mullions. The jamb anchors seat against the vertical studs (not shown) or any other wall surface which delineates the opening and are arranged to force the upper mitered end portions of the vertical members 4 and 5 toward the opposite mitered ends of the horizontal header 3. The anchors also permit the assembled sectional frame structure to be adjusted to a plumb position with reference to the wall opening, thus fixing the main frame 2 in position to act as a support for the other sectional components of the side light frame and the doors which are hung within it. The lower ends of the vertical members 4 and 5 rest upon the floor of the building and are anchored to the sills, indicated generally at 8 in FIG. 1.

The transom, indicated generally at 10 (FIG. 1), is delineated by a horizontal transom bar 11 of composite construction extending transversely between the vertical framing members 4 and 5 and delineating the header of the door opening, which is indicated generally at 12 (FIG. 1). In the present example, the structure is arranged to accommodate a pair of doors indicated generally at 13 and 14, which are hung within the opening, as described later. The door opening 12 is delineated by the transom bar 11 and a pair of door jambs 15 and 16 (FIG. 1), also of composite construction, which extend vertically and in parallelism with the vertical main framing members 4 and 5.

The door jambs 15 and 16 extend from the floor level, indicated at 17 (FIG. 1) to the horizontal transom bar 11, at which point they are joined to the transom bar 11 as described later. In addition, each door jamb 15 and 16 includes, as a separate piece, an extension projecting upwardly from the transom bar 11 to the header 3 of the main frame 2, as indicated at 18 and 20.

The lower end portions of the vertical framing members 4 and 5 and the door jambs 15 and 16 rest upon the floor 17 and include the transverse sills 8-8, the sills 8 being anchored to the floor 17 as described later.

Installation

In installing the side light frame assembly, the sectional main frame 2 is first installed within the opening, followed by the components of the side light frame. Preferably, the header 3 is first installed across the top of the opening and may be held in place by frictional engagement with the opposite marginal surfaces of the wall panels 1, as indicated in FIG. 7. After the header 3 is installed, one of the vertical framing members, for example vertical member 4, is pivotally connected to the mitered end 6 of the header 3 (FIG. 1), by means of the corner clip 7, the construction of which is described later.

After being pivotally connected, the vertical framing member 4 is pivoted to its vertical position with its limbs frictionally embracing the opposite marginal portions of the wall 1. Thereafter, the second vertical framing member 5, in a similar manner, is pivotally connected to header 3 by means of the corner clip 7 and is swung to its vertical position, also embracing the opposed marginal surfaces of the wall about the door opening. As noted earlier, the framing members 3, 4 and 5 of the main frame, and also the divider components, consisting of the transom bar 11, the door jambs 15 and 16 and the jamb extension pieces 18 and 20 are all basically of the same U-shaped configuration in cross section, with telescopically interfitted rails to complete the structure, as explained later.

After the main frame 2 is installed, the composite transom bar 11 is placed in position transversely between the vertical framing members 4 and 5 (FIG. 1). Thereafter, the sills 8-8 may be mounted upon the floor 17, then composite door

jambs 15 and 16 may be installed with their lower end portions resting upon the floor 17 and connected to the sills 8-8. The upper ends of the jambs 15 and 16 are connected to the transom bar 11, as described later, after which the vertical jamb extension pieces 18 and 20, also of composite design, are secured in place.

The structural details of the anchorage of the sills 8 to the floor 17 and the devices for connecting the ends of the dividers, consisting of the composite transom bar 11, jambs 15 and 16 and jamb extension pieces 18 and 20, simplify the assembly of the frame structure, as described below.

Structural Details

As noted earlier, the sectional vertical framing members 4 and 5, and the header 3 of the main frame 2 (FIG. 1) are identical in cross section, each being generally channel-shaped in cross section and embracing the opposite marginal portions of the wall 1 about the door opening. As shown in FIGS. 2 and 6, the framing members 3, 4 and 5 are in the form of sheet metal stampings, each member being of the double rabbet-type, including the stop 21, delineating the rabbets 22-22 (FIGS. 2 and 7). The rabbets 22-22 each include a yieldable limb 23, completing the channel-shaped cross section, and each limb 23 includes an in-turned flange 24 which seats against the opposed surfaces of the wall 1.

Corner Clip

As indicated earlier at 7 (FIG. 11), the corner clips 7-7 are of the snap on-type as disclosed in the earlier Woodrum Patent No. 3,222,833.

The upper ends of the vertical framing members 4 and 5 are pivotally connected to the header 3 by means of a tongue (not shown) which interfits a slot formed in the end portion of the header. During installation of the framing members, the header 3 preferably is located across the top of the opening, then the tongues of the vertical framing members 4 and 5 are slipped into the slots of the header to provide a pivotal connection. After the tongues are interfitted with the slots of the header, the vertical framing members 4 and 5 are pivoted, by virtue of the pivotal connection, with reference to the wall opening to their vertical positions to provide the snap connection with the corner clips 7, as described below.

Described generally (FIG. 11), each corner clip 7 comprises a latch plate or stamping 25 secured preferably by welding to the upper end portion of each jamb. The latch plates 25-25 coact with a pair of keeper plates 26 26, consisting of sheet metal stamping and welded in place at the mitered end portion 6 of the header 3 at opposite ends.

Each latch plate 25 includes a corner portion 27 which projects outwardly beyond the mitered end 6 of the jambs on opposite sides. The corner portions 27-27 act as pivots or guides to align the latch plates (and jambs) with the keeper plates 26 so as to bring the jambs and header into precise alignment as the vertical framing members 4 and 5 are pivoted to their final vertical position within the wall opening.

A latching detent 28 forms a part of each corner portion 27 of the latch plate 25, each detent 28 including a curved section 30 providing a camming action. In order to provide the snap-in action, each keeper plate 26 includes a yieldable keeper arm 31 which is spaced from the limb 23 of the header 3 at opposite sides. The keeper plate 26 includes an open slot 32 to receive the latching detent 28 to provide the snap-in connection at the mitered corner 6 of the frame members.

In connecting the framing members 3, 4 and 5 (after the tongue engages the slots to provide the pivot connector) the corner portion 27 first enters the space between the limbs 23 and keeper arms 31, thereby to provide a pilot action to align the members. As the pivotal motion continues, the inclined camming section 30 of the latching detents 28 engage the free end portions of the keeper arms 31, then snap into engagement within the open slots 32 of the keeper arms, thus completing the corner connection.

After the vertical framing members 4 and 5 have been pivoted to their vertical positions and latched by operation of the corner clips 7-7, the lower ends of the vertical members are anchored to the floor 17 by the sills 8-8, noted earlier, which seat upon the floor. The sills 8, each are anchored in position by means of a sill anchor, indicated generally at 33 (FIG. 9) which is secured to the floor 17 by screws 34. Each sill anchor 33 is formed of sheet metal and is generally channel-shaped in cross section, comprising a baseplate 35 secured to the floor and having vertical limbs 36-36 rising from the base. The upper ends of the limbs 36 include angulated upper end portions 37 which provide a camming action with reference to the sill 8.

Generally speaking, the sill 8 is of a two-PIECE construction (FIGS. 5 and 9) consisting of the section 38 and a companion section 40. The sill section 38 includes a stop 41 corresponding to the stop 21 previously described with reference to the framing members 3, 4 and 5. The stop 41 includes a lip 42 overlying an angular section 43, the two parts interfitting one another. The two sections are secured together by screws, as described later.

After assembly of the vertical framing members 4 and 5 and the header 3, with the mitered joints 6 joined by the corner clip 7, the sills 8-8 are anchored to the floor by clamping engagement with the baseplates 35-35 on opposite sides of the opening. The ends of the sill 8-8 are then secured to the lower ends of the vertical framing members 4 and 5, thus securing the main frame permanently in position within the wall opening.

Sill Connection Details

After the main framing members 3, 4 and 5 have been installed in the opening, as described above, each sill 8 is installed upon the floor 17 to anchor the lower ends of the framing members in position with reference to the wall opening.

The end of each sill 8 is anchored to the vertical framing members and 5 after they have been installed with the wall opening. Described with reference to the left-hand sill (FIG. 9) the sill 8 is anchored to the lower end portion of the vertical framing member 4 by means of a pair of brackets 44-44 secured to the rabbets 22 of the vertical framing members, in this case the left hand member. Each bracket 44 includes ears 45-45 at its upper and lower ends and is reinforced by a side flange 46. The composite sill 8 includes holes 47 and the ears 45 include holes 48 which match with the holes 47 when the sill is installed with respect to the vertical member 4. With the sill in position, screws 50, preferably of the sheet metal-type, are threaded through the matching holes 47 and 48, thus anchoring the sill 8 to the vertical member 4.

The sidewalls of the sill sections 38 and 40 also include holes 47 which match the holes 48 formed in the side flanges 46 of bracket 44 (FIG. 9). Screws 50 are threaded through the matching holes at assembly. A similar construction is utilized in anchoring the right-hand sill 8 to the vertical member 5. It will be noted that the end portion of the sill 8, which abuts the vertical member (FIG. 9) is inset as at 51 to accommodate the stop 21 of the vertical member 4 or 5.

Transom Bar

As best shown in FIGS. 3 and 7, the transom bar 11 is of composite construction consisting basically of a sheet metal channel-shaped member 52 having a series of U-shaped clips 53. In order to complete the transom bar 11 and form a symmetrical structure, the U-shaped clips 53 (FIG. 3) include flanges 56-56 underlying the flanges 57-57 of the channel-shaped transom bar includes an internal insert 58, also channel-shaped and having flanges 60-60 seated against the flanges 56 of the clips 53.

In assembling the composite transom bar 11, the insert clips 53 are slipped within the bar 52, and the insert bar 58 is then slipped in position. Thereafter, the cap 55 is slipped upon the clips 53 to complete the assembly (FIG. 3).

Door Jamb Connection

As noted earlier, the lower ends of the door jambs 15 and 16, which delineate the door opening, rest upon the floor 17 and are anchored to sills 8-8 in the same manner as described earlier and shown in FIG. 9 by means of the brackets 44 and the self-threading sheet metal screws 50.

The upper end portion of each door jamb 15 and 16 is connected to the transom bar 11 by means of the U-shaped brackets 61-61 (FIG. 10). In this case, identical U-shaped brackets 61 are secured to the upper surface (rabbets 22) of the transom bar 11 to make the connection with the jamb extension pieces 18 and 20. In a similar manner self-threading sheet metal screws 50 are threaded in place through the vertical door jambs members 15 and 16 and through the apertures 62 of the mounting brackets 61.

The upper ends of the jamb extensions 18 and 20 are secured to the header 3 of the main frame 2 by the use of similar mounting brackets 61-61 welded to the header 3 and secured in place by sheet metal screws 50, as described below.

Jamb Members

As best shown in FIG. 4, the door jambs 15 and 16 (shown generally in FIG. 1) are of composite construction, similar to the transom bar 11, as described above. The jamb extensions, previously indicated at 18 and 20 (FIG. 1) are of similar construction in cross section.

The extension pieces 18 and 20 are also of composite construction, each consisting of a main channel-shaped member 63 (FIGS. 4 and 6), each member having a mullion section 64. To complete the jambs and the extension pieces, and to provide a symmetrical structure, each main channel member 63 (FIG. 4) includes an internal insert bar 65, formed of sheet metal, and generally channel-shaped in cross section. The insert bar 65 includes outwardly projecting flanges 66.

As described above with reference to the transom bar 11, the composite jambs 15 and 16 and their extensions 18 and 20 each include a mullion section 67, also formed of sheet metal including outwardly turned flanges 68 seated against flanges 66 of insert bar 65. Assembling the composite jambs, the insert mullions 67 and the internal reinforcing bar 65 are telescopically interfitted and snapped together, thus forming a rigid assembly.

The lower end portion of the assembled jambs 15 and 16 rest upon the floor 17 and are anchored to the respective sills 8-8 by means of the brackets 44 and screws 50, as described earlier with reference to FIG. 9. It will be understood that the end of the sills which abut the jambs 15 and 16 are inset as previously indicated at 51 to accommodate the stop 21.

Transom Bar Connection

The connections of the opposite ends of the composite transom bar 11 with the main vertical framing members 4 and 5 are illustrated in FIG. 8. The connection of transom bar 11 with the vertical members 4 and 5 (FIG. 8) is identical to the connection of the transom bar to the vertical framing member 5.

Described in detail (FIG. 8) each end of the horizontal transom bar 11 is connected to the vertical main framing members 4 and 5 by means of the pairs of brackets 70 which are U-shaped to provide ears 71-71. The brackets are attached to the rabbets 22 on opposite sides of the stop 21.

Upon installation of the transom bar 11, the ends of bar 11 are placed in abutment with respect to the vertical members 4 and 5 such that the walls 72 of the composite transom bar 11 register with the ears 71-71 of the mounting brackets 70. With the opposite ends of bar 11 in position, sets of screws 73, preferably of the self-threading sheet metal-type, are installed within the matching walls and ears, thus securing the horizontal transom bar to the vertical framing members.

Installation

The frame structure is furnished to the user as sectional parts suitably packaged and ready for installation within the door opening of the wall 1, the door opening having been delineated by suitable vertical studs and a horizontal header (not shown). Preferable the composite framing members, that is the door jambs 15 and 16, the vertical extension pieces 18 and 20, and the composite transom bar 11 are assembled at the manufacturing plant. However, these members can be assembled at the building site if desired or necessary.

At installation in the field, the main frame 2 is first installed within the opening of the wall 1 preferably by placing horizontal header 3 in position and pivoting the vertical framing members about the header by operation of the corner clips 7, as described earlier. After the main framing members 4 and 5 are joined to the opposite ends of the header (mitered joints 6 - FIG. 1) the remaining components of the frame, consisting of vertical door jambs 15 and 16, as described earlier, the lower ends of the jambs 15 and 16 are anchored to the sills 8-8 (previously installed). The transom bar 11 which extends across the entire frame between the vertical framing members 4 and 5 is then installed across the upper ends of the jambs 15 and 16, and the parts are secured together by the sheet metal screws 50, as described earlier.

After the main frame 2 and the inner frame have been installed within the opening, the transom panels 54 and the side light panels 54 are installed within the frame. It will be noted that the panels are seated against the stop sections 21 of the mullions and secured by retainer strips 74 engaging the surface of the panels and being secured in place by the screws 50.

Referring to FIGS. 1 and 6, the frame structure is provided with a pair of doors indicated at 13 and 14. A suitable lock (not shown) secures the doors in closed position when not in use. The doors 13 and 14 (FIG. 6) are hung within the jambs 15 and 16 by means of hinges 75 of conventional design, the hinges being secured to rabbet section 22 of the jambs 15 and 16.

I claim:

1. A sectional side light frame formed of sheet metal and arranged to be installed within an opening formed in a wall and resting upon a floor of a building comprising:

a main frame comprising a header of channel-shaped configuration in cross section disposed in a horizontal position and arranged to be mounted across the top of the wall opening embracing the opposite marginal wall surfaces thereof;

a pair of vertical framing members disposed along the opposite sides of the wall opening and having lower ends resting upon the floor of the building, said vertical members being channel-shaped in cross section and embracing the opposite marginal surfaces of the wall about the wall opening;

the adjoining ends of said horizontal header and vertical framing members being mitered to interfit one another upon installation of the main frame within the wall opening;

means interfitting the upper end portions of the vertical framing members at the mitered end portions thereof and interfitting the mitered end portions of the horizontal header at opposite ends and aligning the mitered end portions of the framing members and header in a common plane with one another;

a pair of sills mounted on the floor, said sills having outer end portions connected to the lower end portions of the vertical framing members which rest upon the floor of the building;

connecting means joining the outer end of the sills to the lower end portions of the vertical framing members which rest upon the floor;

a door frame mounted within the main frame, said door frame including a pair of vertical door jambs spaced inwardly from the vertical framing members of the main frame and resting upon the floor;

the lower ends of the vertical jambs being engaged against the inner ends of said sills;

connecting means securing the lower end portions of the vertical door jambs to the inner ends of the sills and spacing the door jambs inwardly from the vertical members of the main frame;

a transom bar spaced downwardly from the header of the main frame and extending horizontally across the upper ends of the vertical door jambs and having opposite ends abutting the vertical framing members thereby completing the door frame;

said transom bar and door jambs each including a door stop and at least one inset rabbet adjoining the door stop;

said door jambs and transom bar delineating a door opening arranged to receive a door which interfits the inset rabbets of the transom bar and door jambs and seats against the stop rails;

connecting means joining the upper ends of the vertical door jambs to the horizontal transom bar of the door frame;

and connecting means joining the opposite ends of the transom bar to the vertical members of the main frame, whereby the main frame secures the horizontal transom bar and vertical door jambs in a spaced position within the main frame, adapting a door to be hinged relative to the door jambs and transom bar.

2. A sectional side light frame formed of sheet metal and arranged to be installed within an opening formed in a wall and resting upon the floor of a building comprising:

a main frame comprising a header of channel-shaped configuration in cross section disposed in a horizontal position and arranged to be mounted across the top of the wall opening embracing the opposite marginal wall surfaces thereof;

a pair of vertical framing members disposed along the opposite sides of the wall opening and having lower ends resting upon the floor of the building, said vertical members being channel-shaped in cross section and embracing the opposite marginal surfaces of the wall about the wall opening;

the adjoining ends of said horizontal header and vertical framing members being mitered to interfit one another upon installation of the main frame within the wall opening;

corner clips secured to the upper mitered ends of the vertical framing members and projecting upwardly therefrom, the corner clips having end portions interfitting the end portions of the horizontal header and aligning the vertical framing members and header in a common plane with one another, said corner clips including means securing the mitered end portions of the header and framing members together;

a pair of sills mounted upon the floor and secured thereto; connecting brackets securing the outer ends of the sills to the lower end portions of the vertical framing members which rest upon the floor;

a door frame mounted within said main frame, said door frame comprising a pair of vertical door jambs spaced inwardly from the vertical framing members of the main frame and resting upon the floor;

said vertical door jambs being channel-shaped in cross section;

connecting brackets securing the lower end portions of the vertical door jambs to the inner ends of the sills, thereby spacing the jambs inwardly from the vertical members of the main frame;

a transom bar spaced downwardly from the header of the main frame and extending horizontally across the upper ends of the vertical door jambs and completing the door frame;

said transom bar being generally channel-shaped in cross section and having opposite ends abutting the vertical framing members of the main frame;

connecting brackets secured to the vertical members of the main frame and interfitting the abutting end portions of the transom bar and secured thereto;

the upper ends of said vertical door jambs abutting the horizontal transom bar at points spaced inwardly from the vertical framing members;

connecting brackets secured to the transom bar and projecting into the abutting end portions of the channel-shaped door jambs and securing the upper ends of the vertical jambs to the horizontal transom bar;

said transom bar and door jambs each including a door stop and at least one inset rabbet adjoining the door stop;

said door jambs and transom bar providing a door opening to receive a door hinged within the door frame.

3. A sectional side light frame formed of sheet metal as set forth in claim 2 in which there is provided a pair of sill anchors formed of sheet metal, each of said sill anchors being generally channel-shaped in cross section having a base plate secured upon the floor and having vertical limbs rising from the base plate, said sills each being generally channel-shaped in cross section comprising an upper web section, a pair of vertical limbs extending downwardly from the upper web section, each limb having an inturned lip, the inner ends of the inturned lips normally being spaced apart a distance less than the spacing of the vertical limbs of the sill anchor, the limbs of the sill being sprung apart with said inturned lips resting upon the floor, the sill being mounted upon the floor by engagement of the inturned lips with respect to the vertical limbs of the sill anchor.

4. A sectional side light frame formed of sheet metal as set forth in claim 2 in which there is provided a pair of sill anchors formed of sheet metal, each of said sill anchors being generally channel-shaped in cross section having a baseplate secured upon the floor and having vertical limbs rising from the baseplate, the upper end of said limbs including angulated portions bent inwardly toward one another, said sills each being generally channel-shaped in cross section comprising an upper web section, a pair of vertical limbs extending downwardly from the upper web section, each limb having an inturned lip, the inner ends of the inturned lips normally being spaced apart a distance less than the spacing of the vertical limbs of the sill anchor, the inturned lips of the sills resting upon the floor, whereby the inturned lips of the sill are sprung apart and mounted upon the floor by a camming action of the inturned lips with respect to the angulated upper end portions of the limbs of the sill anchor.

5. A sectional side light frame formed of sheet metal as set forth in claim 2 in which the connecting brackets which secure the outer ends of the sill to the lower end portions of the vertical framing members of the main frame, each comprise a pair of brackets secured to the lower end portions of the vertical framing members, said brackets being U-shaped in the horizontal plane and comprising a vertical web secured to the lower end portion of each vertical framing member and a pair of ears projecting horizontally and outwardly from the upper

and lower ends of the vertical web and extending outwardly along the outer edges of said vertical framing member on opposite sides thereof, said ears interfitting the interior of the sill at its end portion which adjoins the vertical framing member, said sill and said ears having matching apertures, and screws passing through said matching apertures and securing the outer end portions of the sills to the said ears.

6. A sectional side light frame formed of sheet metal as set forth in claim 2 in which the transom bar is formed of sheet metal and is of hollow composite construction comprising a main member which is generally channel-shaped in cross section having an open side, a plurality of generally U-shaped insert clips interfitted within the channel-shaped transom bar, an internal reinforcing insert channel-shaped in cross section, disposed within the channel-shaped transom bar, the hollow, channel-shaped transom bar having inturned lips at its open side, said insert clips having outwardly turned lips seated against and secured to the inturned lips of the transom bar, said reinforcing insert having inturned lips seated against and secured to the outwardly turned lips of the insert clips, and a cap, generally U-shaped in cross section telescopically inserted upon the U-shaped portion of the said insert clips and secured thereto.

7. A sectional side light frame formed of sheet metal as set forth in claim 2 in which the transom bar is hollow in cross section and in which the vertical framing members of the main frame each include a pair of connecting brackets located at an intermediate point along the length of the vertical framing members, the brackets being U-shaped as viewed in the horizontal plane, each bracket including a pair of ears extending outwardly in a horizontal plane, said ears interfitting the end portions of the hollow transom bar, said transom bar and said ears having apertures which match with one another upon installation of the end portions of the transom bar in an abutting relationship with the vertical framing members, and a plurality of screws threaded through the said matching apertures and thereby securing the end portions of the transom bar to the framing members.

8. A sectional side light frame formed of sheet metal as set forth in claim 2 in which the vertical door jambs of the door frame, which are spaced inwardly from the vertical framing members of the main frame, are hollow in cross section and in which the horizontal transom bar includes pairs of brackets which are U-shaped as viewed in the horizontal plane, said brackets each including a pair of spaced ears projecting downwardly in a vertical direction at right angles with reference to the transom bar, said hollow vertical door jambs having upper end portions interfitting the spaced ears of said brackets, the upper end portions of the vertical door jambs and the ears of said brackets having matching apertures, and a plurality of screws threaded through said matching apertures and securing the upper end portions of the vertical door jambs to the vertical ears of the U-shaped brackets of the horizontal transom bar.

60

65

70

75