



INTERNATIONAL APPLICATION PUBLISHED UNDER THE PATENT COOPERATION TREATY (PCT)

<p>(51) International Patent Classification ⁵ : A61F 5/04</p>	<p>A1</p>	<p>(11) International Publication Number: WO 93/01773 (43) International Publication Date: 4 February 1993 (04.02.93)</p>
<p>(21) International Application Number: PCT/US92/06039 (22) International Filing Date: 21 July 1992 (21.07.92) (30) Priority data: 735,524 23 July 1991 (23.07.91) US (71)(72) Applicant and Inventor: MIKHAIL, W., E., Michael [US/US]; 4203 Shamley Green, Toledo, OH 43623 (US). (72) Inventors: ELTING, James, J. ; 35 Academy Street, Oneonta, NY 13620 (US). LING, Robin, S., M. ; GIE, Graham, A. ; 2 The Quadrant, Wonford Road, Exeter EX2 4LE (GB). SLOFF, Tom, J., J., H. ; University Hospital, St. Radboud Th., Craanenlaan 7, Posbus 9101, NL-6500 HB Nijmegen (NL).</p>		<p>(74) Agents: PORCELLO, James, F., Jr. et al.; Emch, Schaffer, Schaub & Porcello Co., P.O. Box 916, Toledo, OH 43697-0916 (US). (81) Designated States: AU, CA, JP, European patent (AT, BE, CH, DE, DK, ES, FR, GB, GR, IT, LU, MC, NL, SE). Published <i>With international search report.</i> <i>With amended claims and statement.</i></p>

(54) Title: SYSTEM FOR PERFORMING HIP PROSTHESIS REVISION SURGERY

(57) Abstract

A method and apparatus for performing hip prosthesis revision surgery includes preparation of the cavity (57) left after removal of the original prosthesis (11). A tamp (70) having a longitudinal passageway (74) extending longitudinally through the stem portion (71) thereof and a guidewire (62) positioned in the cavity (57) function to compact bone graft material (65) in the cavity (57) and form a precisely contoured new hip prosthesis receiving cavity (78).

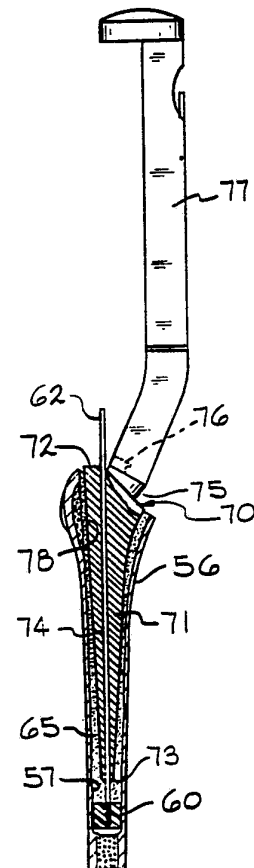

FOR THE PURPOSES OF INFORMATION ONLY

Codes used to identify States party to the PCT on the front pages of pamphlets publishing international applications under the PCT.

AT	Austria	FI	Finland	MI	Mali
AU	Australia	FR	France	MN	Mongolia
BB	Barbados	GA	Gabon	MR	Mauritania
BE	Belgium	GB	United Kingdom	MW	Malawi
BF	Burkina Faso	GN	Guinea	NL	Netherlands
BG	Bulgaria	GR	Greece	NO	Norway
BJ	Benin	HU	Hungary	PL	Poland
BR	Brazil	IE	Ireland	RO	Romania
CA	Canada	IT	Italy	RU	Russian Federation
CF	Central African Republic	JP	Japan	SD	Sudan
CG	Congo	KP	Democratic People's Republic of Korea	SE	Sweden
CH	Switzerland	KR	Republic of Korea	SN	Senegal
CI	Côte d'Ivoire	LI	Liechtenstein	SU	Soviet Union
CM	Cameroon	LK	Sri Lanka	TD	Chad
CS	Czechoslovakia	LU	Luxembourg	TG	Togo
DE	Germany	MC	Monaco	US	United States of America
DK	Denmark	MG	Madagascar		
ES	Spain				

- 2 -

5 A number of prior art devices have been utilized for aligning
drills or reamers in the performance of revision hip surgery. U.S.
Patent No. 4,860,735 relates to a drill alignment guide for
osteoplastic surgery in which an alignment rod is supported on a
clamp element affixed to the femur. The drill is mounted for
10 movement with an alignment rod which is parallel to and disposed a
predetermined distance from a shaft of the drill. As the drill is
moved forward, the forward end of the alignment rod moves through
an aperture of the clamp element thereby insuring that drilling
occurs along a predetermined drilled path extending along the bone
15 axis.

U.S. Patent No. 4,686,972 relates to a surgical deflector and
drilling guide for guiding a drill bit, awl or reamer into a bone. The
boring-tool guide assembly comprises a sleeve having a T-shaped nib
which can be detachably inserted into a corresponding bracket
20 permanently mounted against a tool having teeth designed to anchor
the tool on a boney tissue. The surgeon can insert the tip of a drill
bit, awl or reamer into the sleeve of the guide assembly when the
teeth are anchored onto the boney tissue to obtain means for guiding
the boring tool.

25 A method of economically removing cement from the femoral
canal during revision surgery appeared in the publication
"Orthopedics Today", September 1989, pages 18 and 19. Under the
procedure described therein, a side cut and end cut reamer positioned
in a guide sleeve is utilized to remove the cement.

30 A catalog entitled "OmniflexTM Femoral System Surgical
Protocol Press-Fit" copyright 1988 by Osteonics Corp., describes a
cement removal system utilizing a tapered axial reamer.

U.S. Patent No. 4,919,673 is directed to a femoral head
prosthesis having a fixing stem with a longitudinal bore utilizing a
35 centering rod extending therethrough and engaged to a barrier at the
lower end of the bone cavity.

- 3 -

5 Following removal of all of the old plastic cement and any
cement restricter or plug which may have been used, the cavity
remaining in the femur will be substantially larger than is necessary
or desirable to accomodate the new femoral hip prosthesis.
Accordingly, it is generally accepted procedure to place crushed
10 cancellous bone graft in the enlarged cavity or femoral canal. Prior
to positioning the new prosthesis in the femoral canal, the crushed
cancellous bone graft is tamped in order to compact it and have it
tightly packed in the femoral canal. The stem of the new prosthesis
is then placed in the femoral canal with bone cement if the prosthesis
15 is of a type intended for use with bone cement or without bone
cement if such prosthesis is of a type intended to be used without
such bone cement. If the crushed cancellous bone graft is tightly
compacted prior to insertion of the stem of the new prosthesis
therein, it may be necessary to enlarge the new cavity in the
20 compacted crushed cancellous bone graft to receive the new
prosthesis or use a smaller prosthesis than was intended. As is well
known by those skilled in the art, it is necessary that the crushed
cancellous bone graft be tightly compacted to provide for strong
boney structure around the prosthesis and, if it is not compacted
25 sufficiently tightly prior to introduction of the prosthesis, attempts
must be made to further compact it after placement of the new
prosthesis in the femoral canal.

The foregoing prior art references are incorporated herein by
reference and copies are herewith enclosed.

30

DISCLOSURE OF INVENTION

The parent application of the present continuation-in-part
application provides for a new method of performing revision surgery
utilizing improved means for insuring proper centering and guidance
35 for of the reamer utilized for removing old bone cement. Such
centering and guidance means insures proper positioning of the

- 4 -

5 revision prosthesis with an adequate thickness of bone cement there
around and assists in avoiding accidental perforation of the cortex of
the femur. Under such invention, the original femoral component is
removed and then replaced by a cannulated trial femoral component
of similar size and shape to the original prosthesis which has been
10 removed. X-rays taken prior to removal of the original prosthesis
can be used to confirm that the original prosthesis is still properly
aligned in the femoral canal and did not subside within the original
cement mantle into varus. Assuming that the original prosthesis as
removed was properly aligned, the cannulated trial femoral
15 component is then inserted into the cavity left by the removal of the
original prosthesis. An elongated drill is then inserted through the
cannulated stem and, using the passageway of the cannulated stem as
a guide, is utilized to drill through the cement and cement restricter
at the bottom of the cavity thus forming a pilot hole in the cement,
20 restricter and bone marrow therebelow. The pilot hole is sufficiently
large to permit insertion of a bullet guidewire having a slightly
enlarged head at its free end. Following insertion of the bullet guide
wire, cannulated reamers of progressively increasing size are placed
over the bullet guidewire and utilized to progressively increase the
25 size of the prepared canal to (1) remove all of the old bone cement,
centralizer and restricter and (2) reach a size suitable for receiving
new bone cement and the stem of the new femoral hip joint
prosthesis.

As previously discussed, removal of the old bone cement will
30 result in formation of a cavity in the femur significantly larger than
required or desired to receive the new prosthesis and a portion of
such cavity should be filled with crushed cancellous bone graft which
is then tightly compacted therein.

According to the present invention, a method is provided using
35 a cannulated tamp of the present invention to compact crushed
cancellous bone graft placed in such enlarged cavity to the density or

- 5 -

5 tightness desired for optimum grafting with the remaining bone while
at the same time forming a new cavity of the desired shape and size
to receive the new prosthesis with the appropriate amount of bone
cement. The present invention utilizing the cannulated tamp and
10 guidewire may be used in revision surgery performed using alternate
methods of removing bone cement as well as the method of removing
bone cement disclosed in the parent of the present application.

Accordingly, it is object of the present invention to provide a
method and apparatus for performing revision surgery including
specifically a method and apparatus for placement and compacting of
15 crushed cancellous bone graft in an enlarged cavity in a manner
which forms a cavity of the shape and size desired to receive the
stem of a hip prosthesis.

The invention will be more fully understood and other objects
and advantages will become apparent from the following detailed
20 description in conjunction with the attached drawings.

BRIEF DESCRIPTION OF THE DRAWINGS

Fig. 1 is an elevational view, partially in section, showing a
femoral hip joint prosthesis implanted in the femoral canal of a
25 patient.

Fig. 2 is a view similar to Fig. 1 showing the femur with the
previously implanted femoral hip joint prosthesis removed.

Fig. 3 is a view similar to Figs. 1 and 2 showing the cannulated
trial femoral component of the present invention positioned within
30 the cavity previously occupied by the original femoral hip joint
prosthesis.

Fig. 4 is a view similar to Fig. 3 but showing the drilling of a
pilot passageway utilizing the cannulated trial femoral component as
a guide.

35 Fig. 5 is a view similar to Fig. 4 following removal of the
elongated drill bit and insertion of the guidewire with its enlarged

- 6 -

5 bullet head through the guide passageway of the cannulated trial femoral component and into the newly drilled pilot hole.

 Fig. 6 is a view similar to Fig. 5 but slightly enlarged for clarity, showing the reaming of the canal following removal of the cannulated trial stem and showing the first of several progressively larger reamers being utilized with the bullet guidewire as a guide to control the path of the reamer.

 Figs. 7 and 8 are view similar to Fig. 6 showing the femur as the canal is progressively enlarged with still larger reamers utilizing the bullet guidewire as a guide.

 Fig. 9 is a sectional view of a femur prepared for revision surgery with the old cement removed and the guidewire removed.

 Fig. 10 is a sectional view of a femur prepared for revision surgery showing placement of a new cement restricter.

 Fig. 11 is a view similar to Fig. 10 showing the next step of revision surgery.

 Fig. 12 is an elevational view of the cannulated tamp of the present invention.

 Fig. 13 is a view showing the guidewire to be used with the cannulated tamp in performing the method of the present invention.

 Fig. 14 is a sectional view showing the tamp with the guidewire extending therethrough positioned to compact bone graft material in the femur.

 Fig. 15 is a sectional view showing a new prosthesis implanted in the femur.

30

BEST MODE OF CARRYING OUT INVENTION

 Referring now to Fig. 1, there is shown a femur generally designated by the number 10 having implanted therein a hip joint prosthesis 11 having a stem 12 implanted within the intramedullary canal 13 of the femur. The stem extends from a lower distal end 14 to an upper portion which includes an enlarged shoulder 15 and a neck portion 16 disposed at an obtuse angle relative to the stem 12.

- 7 -

5 The prosthesis 11 is typically secured in the femoral
intramedullary canal 13 by a cement mantle 17 of
polymethylmethacrylate (PMMA) or other suitable bone cement. A
restrictor 18 is placed in the intramedullary canal 13 prior to
introduction of the bone cement 17 therein. The distal end 14 of the
10 stem may be engaged in a centralizer 19 which assists in centering
the distal end 14 during the step of implantation of the prosthesis 11
in the cement 17. The prosthesis 11 may be provided with an
aperture 20 or other suitable grasping means to assist in its removal.
As shown in Fig. 2, the removal of the prosthesis 11 leaves a cavity
15 25 conforming to the shape of the removed stem 12. Obviously, prior
to removal of the prosthesis 11, any portion of the cement mantle 17
such as that overlying the enlarged shoulder 15 as indicated by the
numeral 26 in Fig. 1, must be removed. As can be seen in Fig. 2, the
restrictor 18 and centralizer 19 remain within the intramedullary
20 canal 13 following removal of the prosthesis 11 as does the cement
mantle 17 which retained the prosthesis 11.

It is desirable that all of the old cement 17 be removed prior to
implantation of a new prosthesis in the intramedullary canal 13. In
order to effect such cement removal efficiently and with minimal
25 risk to the patient, guide means for the drill and reamer are utilized
for such removal. Referring to Fig. 3, there is shown a cannulated
trial femoral component 30 following its insertion into the cavity 25
left by removal of the original prosthesis 11. The cannulated trial
femoral component 30 preferably has a stem 31 which is shaped
30 substantially the same as the shape of the stem of the original
prosthesis 11. The stem 31 extends from a distal end 32 to an
enlarged upper end 34 extending out of the cavity 25. The stem 31
has a longitudinally extending passageway 33 which extends from the
distal end 32 to the upper end 34 where it forms an outlet opening 35.

35

- 8 -

5 Prior to removal of the original prosthesis 11, X-rays should be taken to determine that the stem 12 of such original prosthesis was properly aligned in the intramedullary canal 13 and that it did not shift into varus as a result of subsidence within the cement mantle. Such subsidence within the cement mantle is known to occur over a period of time.

10 As shown in Fig. 4, there is provided a drill 40 having an elongated drill bit 41. The drill bit 41 has a length permitting it to extend completely through the longitudinal passageway 33 of the cannulated trial femoral component 30 and a substantial distance beyond. Thus, as shown in Fig. 4, the drill bit 41 is of sufficient
15 length to drill, using the longitudinal passageway 33 as a guide, through the centralizer 19, restricter 18 and a substantial distance into the intramedullary canal 13 forming a new channel 42 below the restricter 18.

20 Referring now to Fig. 5, there is shown a bullit guidewire 43 having an enlarged head 44 positioned in the newly drilled channel 42.

Thus, following drilling of the channel 42 through the centralizer 19, restricter 18 and further into the intramedullary canal 13, the drill bit 41 is removed therefrom while leaving the cannulated trial femoral component 30 positioned therein. Thereafter, the guide
25 wire 43 with its enlarged head 44 is inserted through the longitudinal passageway 33 and into the channel 42. Following insertion of the guidewire 43, the cannulated trial femoral component 30 is removed leaving the guidewire 43 in position.

30 Referring now to Fig. 6, following removal of the cannulated trial femoral component 30, a reamer 50 having a hollow stem 51 terminating in an enlarged cutting head 52 is provided. A longitudinal passageway 53 extends through the cutting head 52 and the stem 51. The reamer 50 is telescoped over the bullit guidewire 43 and may be power rotated by any standard well known power
35 means.

- 9 -

5 As can be seen in Figs. 7 and 8, progressively larger reamers 50'
(Fig. 7) and 50" (Fig. 8) with progressively larger cutting heads 52'
and 52" are utilized to progressively enlarge the opening of the cavity
25 and remove the old cement 17, the centralizer 19 and the
restrictor 18 and to progressively enlarge the opening until all of the
10 old cement 17 has been removed and in doing so to utilize the bullit
guidewire 43 to guide it. If desired, as progressively larger reamers
50, 50' and 50" are used, larger diameter guidewires may be inserted,
replacing the small guidewire 43 used for the drill bit 41. The larger
guidewires will give additional rigidity in guiding the path of the
15 reamers.

15 Referring to Fig. 9, following reaming of the old cement 17 in
the lower portion of the femur and reaming of the centralizer 19 and
restrictor 18, the reamer and guidewire 43 may be removed.
Although there will be additional old cement 17 still present in the
20 upper, larger femur portion, it can be readily removed by
conventional techniques.

Referring now to Figs. 10-15, there is shown the method and
apparatus for preparing a newly reamed cavity 57 of femur 56
preparatory to receiving a new femoral hip prosthesis for
25 implantation. Although not limited to such use, the method and
apparatus disclosed and claimed herein is ideally suited for preparing,
in revision surgery, a femur to receive a collarless polished tapered
femoral prosthesis of the type manufactured and sold by Zimmer,
Inc., Warsaw, Indiana as shown in its brochure entitled "The
30 CPT™ Hip System" (copy enclosed) which is incorporated herein by
reference.

Following removal of the old prosthesis, old cement and old
restrictor, a new cement restrictor or plug 60 is placed at or near the
bottom of the cavity 57. Preferably the restrictor 60 is formed of
35 plastic and has a central threaded cavity 61 formed therein. A
guidewire 62 having external threads 63 on its free end is threadedly

- 10 -

5 engaged to the restricter 60. A removable T-bar 64 of conventional
design may be secured to the end of the guidewire 62 extending out
10 of the cavity 57 of femur 56. One such T-bar is one manufactured
and sold by Zimmer, Inc., under the name of T-Handle (Zimmer
Shank) Item No. 6551-60 of the above referenced brochure. The T-
bar 64, when engaged to the guidewire 62 threadedly engaged to the
15 restricter 60 may be used to position the restricter 60 in the cavity
57. While still attached to the guidewire 62, the T-bar 64 is impacted
to drive the restricter 60 to its proper position in the cavity 57. The
T-bar 64 is then removed from the guidewire 62 leaving the guidewire
in place threadedly engaged to the restricter 60.

15 Referring now to Fig. 11, with the guidewire 62 and restricter
60 in place, crushed cancellous bone graft material 65 is then loosely
packed in the cavity 57.

Referring now to Figs. 12 and 14, there is shown a cannulated
20 tamp generally designated by the numeral 70 which, in Fig. 14, is
shown positioned in the cavity 57 of the femur 56 being prepared to
receive a new femoral prosthesis. The tamp includes a stem portion
71 extending from an upper proximal end 72 to a lower distal end 73.
The tamp 70 should have its stem 71 shaped similar to the shape of
the femoral prosthesis intended to be implanted; however, ideally a
25 series of tamps each of varying size will be utilized in performing a
single revision surgery. Smaller sized tamps will be used initially
with progressively larger ones used thereafter until the crushed
cancellous bone graft material is compacted to the desired density
and the new cavity thus formed will be of the desired size. The
30 largest size tamp will be larger than the prosthesis intended to be
implanted by an amount which will permit new bone cement used to
implant such prosthesis to have a thickness of two to four millimeters
in all portions of the stem. Thus, if the surgeon intends to use an
35 implant of the type shown in the above-referenced Zimmer, Inc.
brochure as a "CPT Hip Stem" the tamp 70 will have a stem

- 11 -

5 configuration similar to that of the CPT Hip Stem. Preferably all portions of the stem 71 are polished to a smooth finish.

10 The tamp 70 has a longitudinal passageway 74. The upper or proximal end 72 of the tamp includes a protrusion 75 and knob 76 intended to be engaged by a rasp handle 77 of any desired type such as that disclosed in the above-referenced Zimmer, Inc. brochure as item no. 6601-05. It should be understood that since the longitudinal passageway 74 extends through the distal end 73 of the tamp 70, the tamp 70 may be slightly shorter than the prosthesis to be used in the revision. The passageway 74 must be large enough to permit the tamp 70 to move freely over the guidewire 62.

15 Referring to Fig. 13, there is shown a detailed view of the guidewire 62. The guidewire 62 is approximately 2-5mm in size, and in addition to the threads 63, may have a series of lines 67 for measuring depth to which the restricter is positioned.

20 Referring to Fig. 14, with the rasp handle 77 engaged to the tamp 70 by means of the protrusion 75 and knob 76, the tamp 70 is positioned to be driven into the cavity 57 by means of the rasp handle 76 being impacted by a hammer or other impacting device. With the tamp 70 positioned as indicated in Fig. 14 and with the guidewire 62 extending through the longitudinal passageway 74, the position of the tamp 70 is precisely controlled as it is driven to the desired position within the cavity 57. As will be appreciated by those skilled in the art, from time to time it may be necessary to completely remove the tamp 70 to place additional bone graft material 65 therein in order to provide the sufficient quantity of material for impacting to the proper density. Additionally, as previously noted, it may be desirable to utilize a series of tamps 70 beginning with a smaller tamp and working up progressively to one which is larger than the desired prosthesis to permit an adequate amount of bone cement around such prosthesis on implantation.

35

- 12 -

5 Following tamping of the cancellous bone graft material 65 to
the desired density and the resultant formation of a cavity of the
proper size and shape the tamp may be removed from the newly
formed cavity 78, the rasp handle 77 removed therefrom, and the
guidewire 62 may be unscrewed and removed from the restricter 60.
The new cavity 78 is now ready to receive the new prosthesis.

10 Fig. 15 shows the completed revision surgery with a new
prosthesis 81 having a distal end 82 positioned in a support element
83 implanted in bone cement 88. The support element 83 is formed
of material suitable for implantation in a human body (such as
PMMA) and has an annular sidewall 84 with a closed end 85 and an
15 open top 86 in which the distal end 82 of the new prosthesis 81 is
positioned. The distal end 82 is spaced from the closed end 85 to
allow space for movement of such distal end 82 therein as the
prosthesis 81, over time, subsides within the cement mantle 88 in
which the new prosthesis is implanted. As will be appreciated and as
20 can be seen in Fig. 15, the cement mantle 88 fills the cavity left by
removal of the guidewire 62 from the restricter 60 and compacted
bone graft.

The present invention may be used in revision surgery
irrespective of whether the prosthesis to be replaced was implanted
25 with bone cement or was one designed and used without cement. The
new prosthesis should be implanted in cement following completion of
bone graft as described above.

It is to be understood that the above detailed description of a
preferred embodiment of the invention is provided by way of example
30 only. Various details of design and construction and steps in the
procedure may be modified without departing from the true spirit and
scope of the invention as set forth in the appended claims.

35

- 13 -

5

CLAIMS:

1. A method of performing revision surgery to replace a hip prosthesis (11) having a stem portion (12) previously implanted in the medullary canal (13) of a femur with a new hip prosthesis (81) having a stem portion comprising the steps of:
- 10
- (a) removing said hip prosthesis (11) from said femur;
 - (b) enlarging the space (25) in said femur previously occupied by said hip prosthesis (11) to form a cavity (57) significantly larger than the stem portion of the new hip prosthesis (81) to be implanted therein, said cavity (57) having a bottom and an open top;

15

 - (c) placing a restricter (60) at the bottom of said cavity (57), said restricter (60) having a guidewire (62) engaged thereto, said guidewire (62) extending from said restricter (60) to a point beyond said open top;
 - (d) placing bone graft material (65) in said cavity (57);

20

 - (e) providing a tamp (70) having a stem (71) extending from a proximal end (72) to a distal end (73) and having a configuration similar to the configuration of the stem portion of said new hip prosthesis (81) and having a passageway (74) extending through said stem (71) from said distal end (73) to said proximal end (72);

25

 - (f) placing said tamp (70) over said guidewire (62) with the guidewire (62) extending through said passageway (74);
 - (g) impacting said tamp (70) while guided by said guidewire (62) to compact said bone graft material (65) and to form a prosthesis

- 14 -

receiving cavity (78) larger than and similar in shape to the stem of said new hip prosthesis (81) to be implanted therein.

2. The method according to claim 1 further including the steps of:

5 (h) placing bone cement (88) in said prosthesis receiving cavity (78); and,

(i) positioning a hip prosthesis (81) in said prosthesis receiving cavity (78) with said new bone cement (88) having interfacial contact with the stem portion of said new hip prosthesis (81).

10

3. The method according to claim 2 wherein said stem portion of said new hip prosthesis (81) extends from a proximal end of maximum cross-sectional size to a distal end (82) of minimum cross-sectional size and said distal end (82) has positioned thereover a support element (83) having
15 sidewalls (84) engaged by the portion of said stem adjacent said distal end (82) and a closed end (85), said stem distal end (82) being spaced from closed end (85).

4. A method of performing revision surgery to replace a hip
20 prosthesis (11) having a stem portion (12) previously implanted in a cement mantle (17) in the medullary canal (13) of a femur with a new hip prosthesis (81) having a stem portion comprising the steps of:

(a) removing said hip prosthesis (11) from said femur;

(b) removing substantially all of the cement (17) of said
25 cement mantle to form a cavity (57) significantly larger than the stem portion of the new hip prosthesis (81) to be implanted therein, said cavity (57) having a bottom and an open top;

(c) placing a restricter (60) at the bottom of said cavity (57),
said restricter (60) having a guidewire (62) engaged thereto, said guidewire
30 (62) extending from said restricter (60) to a point beyond said open top;

(d) placing bone graft material (65) in said cavity (57);

- 15 -

5 (e) providing a tamp (70) having a stem (71) extending from a proximal end (72) to a distal end (73) and having a configuration similar to the configuration of the stem portion of said new hip prosthesis (81) and having a passageway (74) extending through said stem (71) from said distal end (73) to said proximal end (72);

(f) placing said tamp (70) over said guidewire (62) with the guidewire (62) extending through said passageway (74);

10 (g) impacting said tamp (70) while guided by said guidewire (62) to compact said bone graft material (65) and to form a prosthesis receiving cavity (78) larger than and similar in shape to the stem of said new hip prosthesis (81) to be implanted therein.

5. The method according to claim 4 further including the steps of:

15 (h) placing new bone cement (88) in said prosthesis receiving cavity (78); and,

(i) positioning a new hip prosthesis (81) in said prosthesis receiving cavity (78) with said new bone cement (88) having interfacial contact with the stem portion of said new hip prosthesis (81).

20 6. The method according to claim 5, wherein said stem portion of said new hip prosthesis (81) extends from a proximal end of maximum cross-sectional size to a distal end (82) of minimum cross-sectional size and said distal end (82) has positioned thereover a support element (83) having sidewalls (84) engaged by the portion of said stem adjacent said distal end (82) and a closed end (85), said stem distal end (82) being spaced from closed end (85).

30 7. A method of preparing the medullary canal (13) of a femur for implantation of a hip prosthesis (81) having a stem portion comprising the steps of:

- 16 -

(a) forming a cavity (57) significantly larger than the stem portion of the hip prosthesis (81) to be implanted therein, said cavity (57) having a bottom and an open top;

5 (b) placing a restricter (60) at the bottom of said cavity (57), said restricter (60) having a guidewire (62) engaged thereto, said guidewire (62) extending from said restricter (60) to a point beyond said open top;

(c) placing bone graft material (65) in said cavity (57);

10 (d) providing a tamp (70) having a stem (71) extending from a proximal end (72) to a distal end (73) and having a configuration similar to the configuration of the stem portion of said new hip prosthesis (81) and having a passageway (74) extending through said stem (71) from said distal end (73) to said proximal end (72);

(e) placing said tamp (70) over said guidewire (62) with the guidewire (62) extending through said passageway (74);

15 (f) impacting said tamp (70) while guided by said guidewire (62) to compact said bone graft material (65) and to form a prosthesis receiving cavity (78) larger than and similar in shape to the stem of said hip prosthesis (81) to be implanted therein.

20 8. The method according to claim 7 further including the steps of:
(h) placing bone cement (88) in said prosthesis receiving cavity (78); and,

25 (i) positioning a hip prosthesis (81) in said prosthesis receiving cavity (78) with said bone cement (88) having interfacial contact with the stem portion of said hip prosthesis (81).

30 9. The method according to claim 8, wherein said stem portion of said hip prosthesis (81) extends from a proximal end of maximum cross-sectional size to a distal end (82) of minimum cross-sectional size and said distal end (82) has positioned thereover a support element (83) having sidewalls (84) engaged by the portion of said stem adjacent said distal end (82)

- 17 -

and a closed end (85), said stem distal end (82) being spaced from closed end (85).

- 5 10. Apparatus for use in preparing a femoral cavity (78) to receive
bone graft material (65) and a femoral hip prosthesis (81) comprising:
- (a) a guidewire (62);
 - (b) means (60) for supporting said guidewire (62)
longitudinally in said cavity (57); and,
 - (c) cannulated tamp (70) means having a stem (71)
10 extending from a proximal end (72) having a relatively large cross-sectional
size and tapering to a distal end (73) having a relatively small cross-sectional
size, said stem (71) having a passageway (74) sized to slideably receive said
guidewire (62), said passageway (74) extending from said proximal end (72)
to said distal end (73).

15

5

AMENDED CLAIMS

[received by the International Bureau on 21 December 1992 (21.12.92);
original claims 1-4,6,7 and 9 amended; new claims 11-13 added;
other claims unchanged (5 pages)]

10

CLAIMS:

- 15 1. A method of performing revision surgery to replace a
previously implanted hip prosthesis (11) having a stem portion (12) previously
implanted in a medullary canal (13) of a femur with a new hip prosthesis (81)
having a stem portion of predetermined configuration comprising the steps of:
- (a) removing said previously implanted hip prosthesis (11)
from said femur thereby leaving a space (25) in said femur;
 - 20 (b) enlarging said space (25) in said femur previously
occupied by said previously implanted hip prosthesis (11) to form a cavity
(57) larger than the stem portion of the new hip prosthesis (81) to be
implanted therein, said cavity (57) having a bottom and an open top;
 - (c) placing a restricter (60) at the bottom of said cavity (57),
25 said restricter (60) having a guidewire (62) engaged thereto, said guidewire
(62) extending from said restricter (60) to a point beyond said open top;
 - (d) placing bone graft material (65) in said cavity (57);
 - (e) providing a tamp (70) having a stem (71) extending from
a proximal end (72) to a distal end (73) and having a configuration similar to
30 said predetermined configuration and having a passageway (74) extending
through said tamp stem (71) from said distal end (73) to said proximal end
(72);
 - (f) placing said tamp (70) over said guidewire (62) with the
guidewire (62) extending through said passageway (74);
 - 35 (g) impacting said tamp (70) while guided by said guidewire
(62) to compact said bone graft material (65) and to form a prosthesis
receiving cavity (78) larger than and similar in shape to said predetermined
configuration.

2. The method according to claim 1 further including the steps of:
(h) placing new bone cement (88) in said prosthesis receiving cavity (78); and,

5 (i) positioning said new hip prosthesis (81) in said prosthesis receiving cavity (78) with said new bone cement (88) having interfacial contact with the stem portion of said new hip prosthesis (81).

3. The method according to claim 2 wherein said stem portion of said new hip prosthesis (81) extends from a proximal end of maximum cross-sectional size to a distal end (82) of minimum cross-sectional size and said
10 distal end (82) has positioned thereover a support element (83) having sidewalls (84) engaged by said stem adjacent said distal end (82) and a closed end (85), said stem distal end (82) being spaced from closed end (85).

15 4. A method of performing revision surgery to replace a hip prosthesis (11) having a stem portion (12) previously implanted in a cement mantle (17) in a medullary canal (13) of a femur with a new hip prosthesis (81) having a stem portion of predetermined configuration comprising the steps of:

20 (a) removing said previously implanted hip prosthesis (11) from said femur;

(b) removing substantially all of said cement mantle to form a cavity (57) larger than the stem portion of the new hip prosthesis (81) to be implanted therein, said cavity (57) having a bottom and an open top;

25 (c) placing a restricter (60) at the bottom of said cavity (57), said restricter (60) having a guidewire (62) engaged thereto, said guidewire (62) extending from said restricter (60) to a point beyond said open top;

(d) placing bone graft material (65) in said cavity (57);

30 (e) providing a tamp (70) having a stem (71) extending from a proximal end (72) to a distal end (73) and having a configuration similar to said predetermined configuration and having a passageway (74) extending through said stem (71) from said distal end (73) to said proximal end (72);

(f) placing said tamp (70) over said guidewire (62) with the guidewire (62) extending through said passageway (74);

(g) impacting said tamp (70) while guided by said guidewire (62) to compact said bone graft material (65) and to form a prosthesis receiving cavity (78) larger than and similar in shape to said predetermined configuration.

5

5. The method according to claim 4 further including the steps of:

(h) placing new bone cement (88) in said prosthesis receiving cavity (78); and,

(i) positioning a new hip prosthesis (81) in said prosthesis receiving cavity (78) with said new bone cement (88) having interfacial contact with the stem portion of said new hip prosthesis (81).

10

6. The method according to claim 5, wherein said stem portion of said new hip prosthesis (81) extends from a proximal end of maximum cross-sectional size to a distal end (82) of minimum cross-sectional size and said distal end (82) has positioned thereover a support element (83) having sidewalls (84) engaged by said stem adjacent said distal end (82) and a closed end (85), said stem distal end (82) being spaced from closed end (85).

15

7. A method of preparing a medullary canal (13) of a femur for implantation of a hip prosthesis (81) having a stem portion of predetermined configuration comprising the steps of:

20

(a) forming a cavity (57) larger than said predetermined configuration, said cavity (57) having a bottom and an open top;

25

(b) placing a restricter (60) at the bottom of said cavity (57), said restricter (60) having a guidewire (62) engaged thereto, said guidewire (62) extending from said restricter (60) to a point beyond said open top;

(c) placing bone graft material (65) in said cavity (57);

30

(d) providing a tamp (70) having a stem (71) extending from a proximal end (72) to a distal end (73) and having a configuration similar to said predetermined configuration and having a passageway (74) extending through said stem (71) from said distal end (73) to said proximal end (72);

(e) placing said tamp (70) over said guidewire (62) with the guidewire (62) extending through said passageway (74);

(f) impacting said tamp (70) while guided by said guidewire (62) to compact said bone graft material (65) and to form a prosthesis receiving cavity (78) larger than and similar in shape to said predetermined configuration.

5

8. The method according to claim 7 further including the steps of:

(h) placing bone cement (88) in said prosthesis receiving cavity (78); and,

(i) positioning a hip prosthesis (81) in said prosthesis receiving cavity (78) with said bone cement (88) having interfacial contact with the stem portion of said hip prosthesis (81).

10

9. The method according to claim 8, wherein said stem portion of said hip prosthesis (81) extends from a proximal end of maximum cross-sectional size to a distal end (82) of minimum cross-sectional size and said distal end (82) has positioned thereover a support element (83) having sidewalls (84) engaged by said stem adjacent said distal end (82) and a closed end (85), said stem distal end (82) being spaced from closed end (85).

15

10. Apparatus for use in preparing a femoral cavity (78) to receive bone graft material (65) and a femoral hip prosthesis (81) comprising:

20

(a) a guidewire (62);

(b) means (60) for supporting said guidewire (62) longitudinally in said cavity (57); and,

25

(c) cannulated tamp (70) means having a stem (71) extending from a proximal end (72) having a relatively large cross-sectional size and tapering to a distal end (73) having a relatively small cross-sectional size, said stem (71) having a passageway (74) sized to slideably receive said guidewire (62), said passageway (74) extending from said proximal end (72) to said distal end (73).

30

11. Apparatus according to claim 10, wherein said means for supporting said guidewire (62) comprises a restricter (60) sized to be received in said femoral cavity (78).

12. Apparatus for performing revision surgery to replace a previously implanted hip prosthesis (11) having a stem portion (12) previously implanted in a medullary canal (13) of a femur with a new hip prosthesis (81) having a stem portion of predetermined configuration comprising:

5 (a) a tamp (70) having a stem (71) extending from a proximal end (72) to a distal end (73) and having a configuration similar to said predetermined configuration and having a passageway (74) extending through said tamp stem (71) from said distal end (73) to said proximal end (72);

10 (b) a guidewire (62) extending through said passageway (74); and

(c) means (60) for supporting said guidewire (62) in said medullary canal (13), wherein said tamp (70) is movable over said guidewire (62) into and out of said medullary canal (13) to compact bone graft material (65) placed therein.

15

13. Apparatus according to claim 12 further including a restricter (60) at the bottom of said cavity (57), said restricter (60) having said guidewire (62) engaged thereto, said guidewire (62) extending from said restricter (60) to a point beyond said medullary canal (13).

20

STATEMENT UNDER ARTICLE 19

Applicant has provided amendments to claims 1, 2, 3, 4, 6, 7, and 9 to better describe applicant's invention. Further, applicant has submitted new claims 11-13 which better distinguish the apparatus of applicant's invention in view of the cited art of record.

Applicant submits that the amendments to the claims and the newly added claims 11-13 clarify applicant's invention and place the claims in such condition as to be novel and involving an inventive step when viewed in light of the cited art of record.

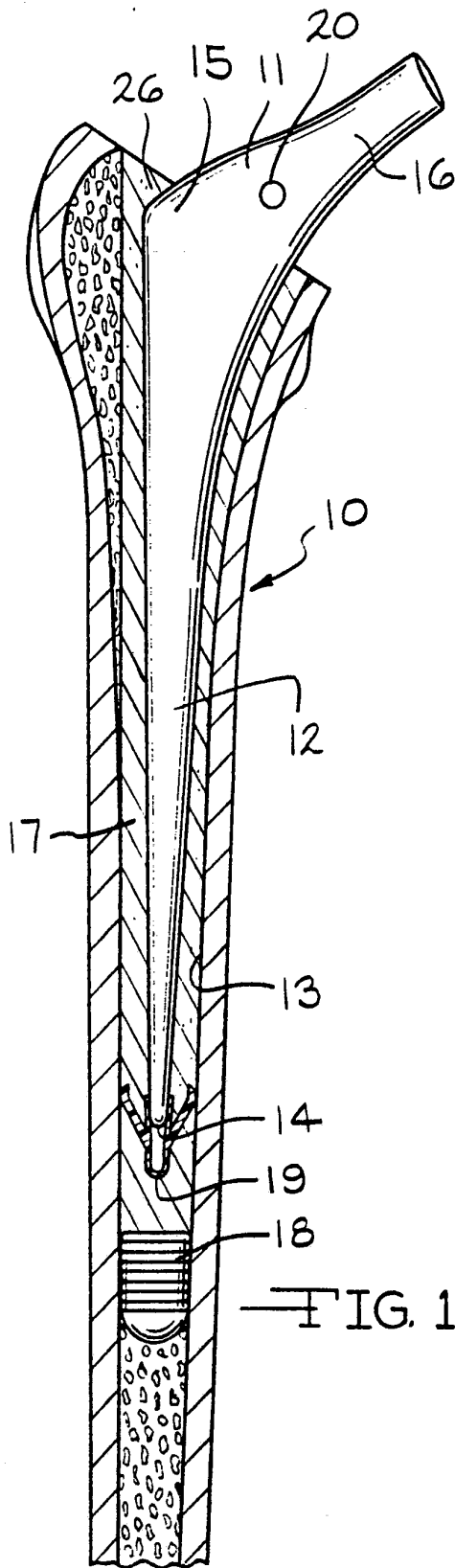

FIG. 1

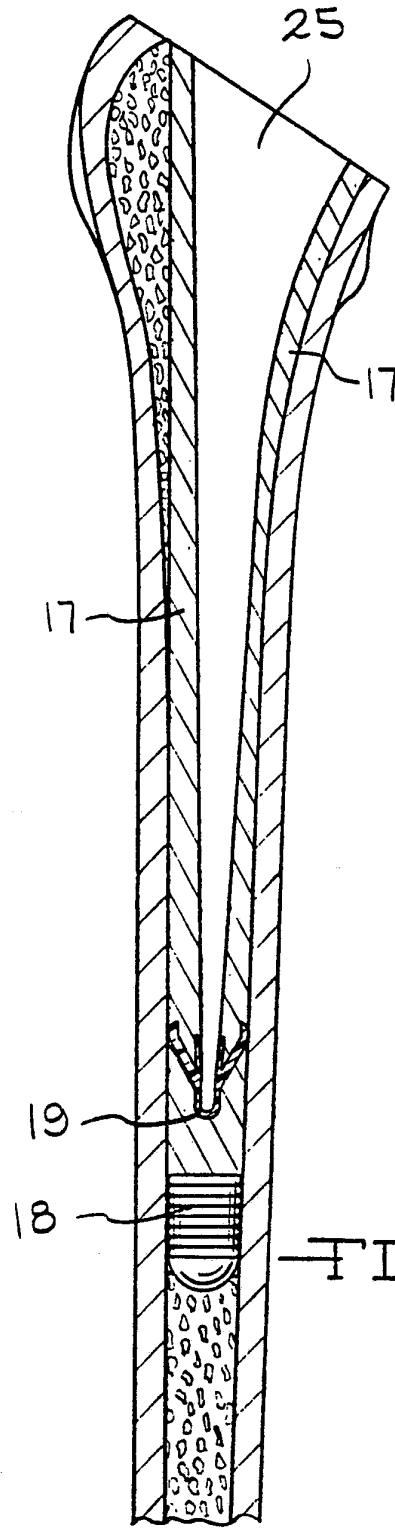
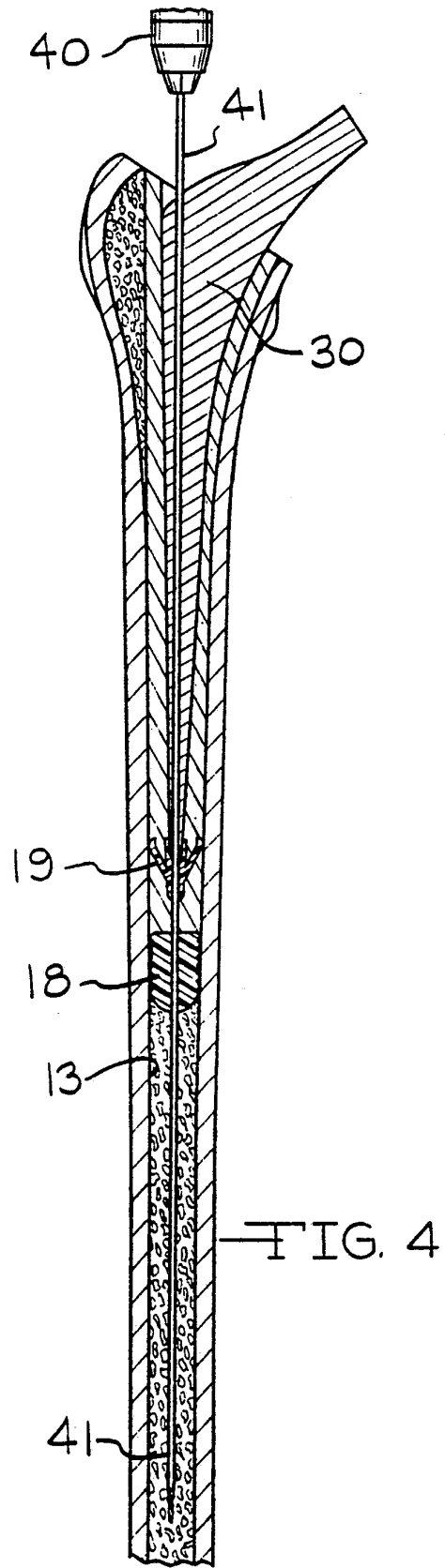
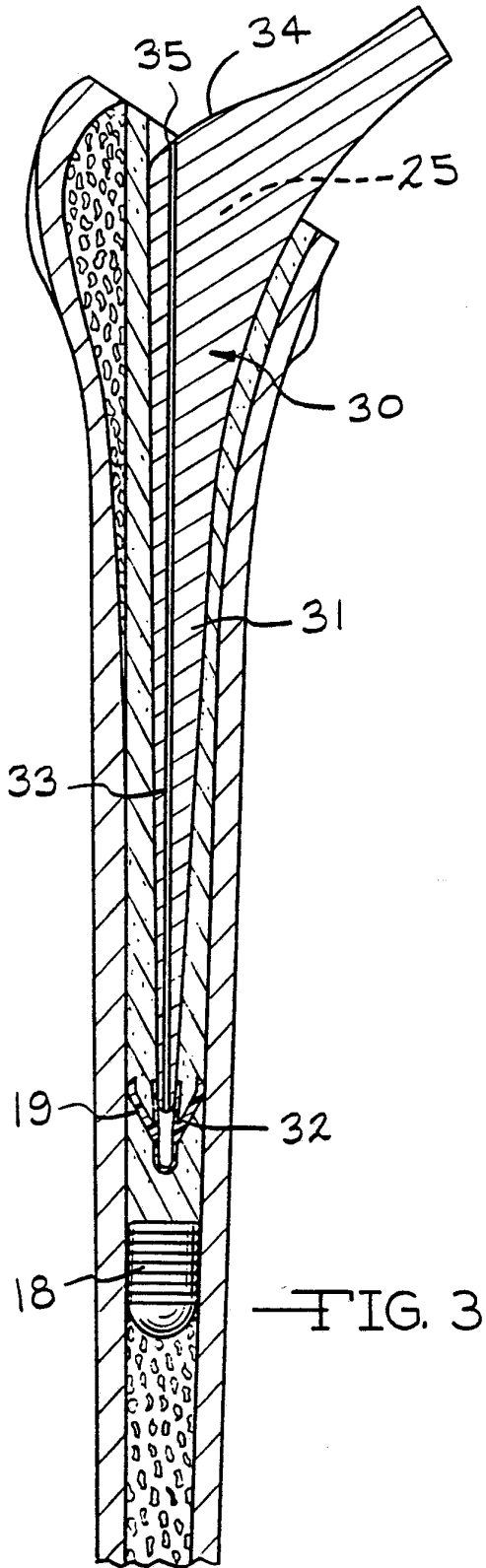
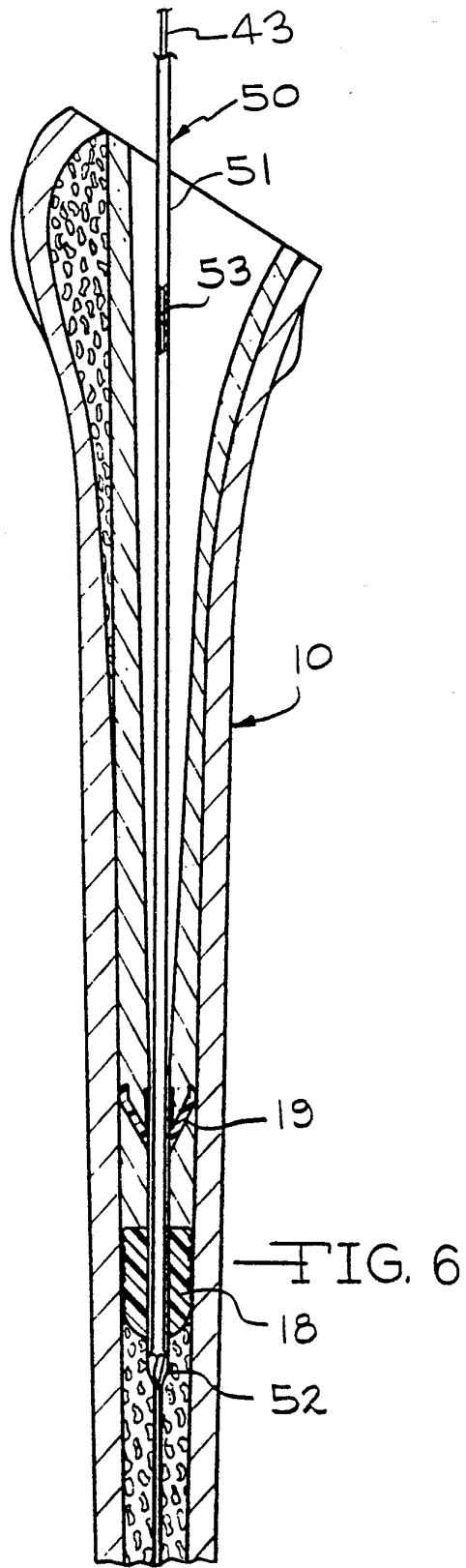
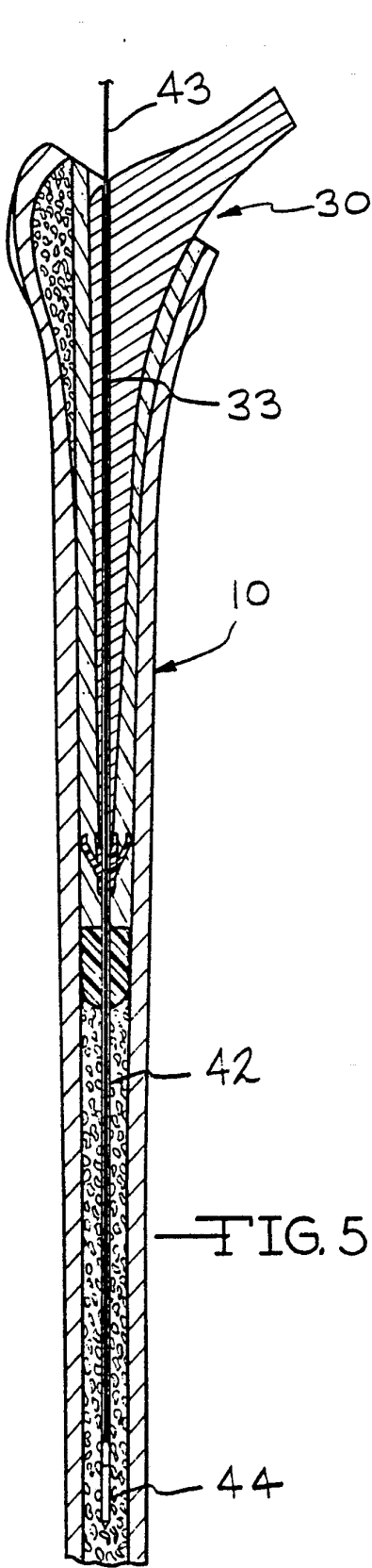
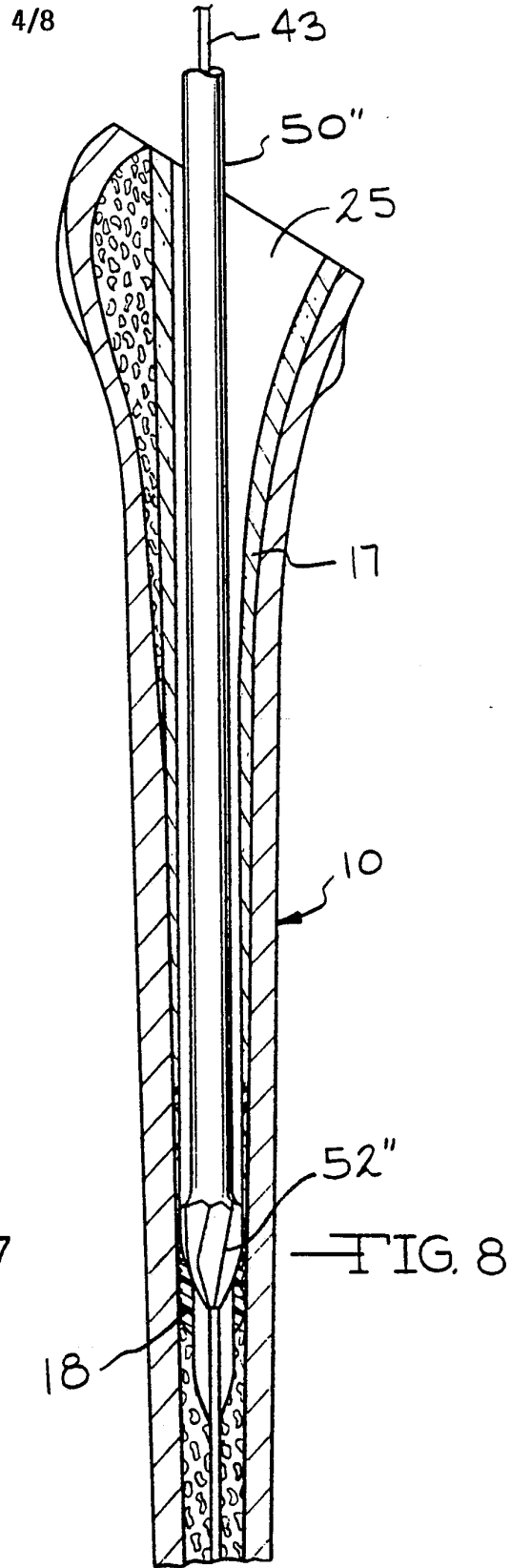
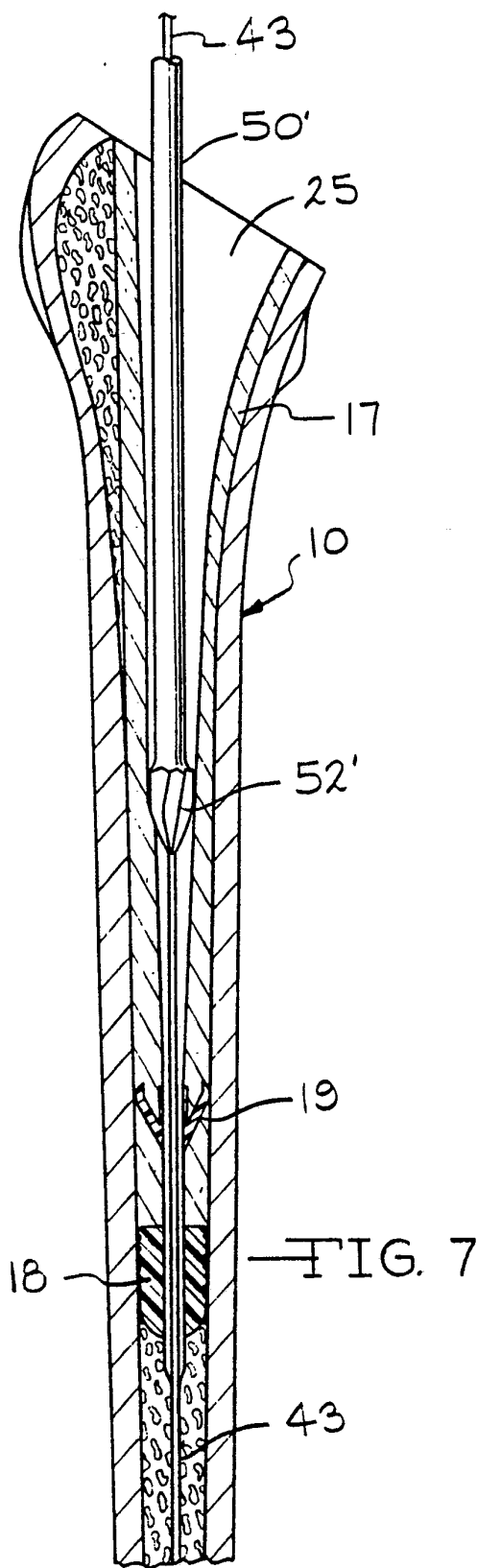

FIG. 2





SUBSTITUTE SHEET



5/8

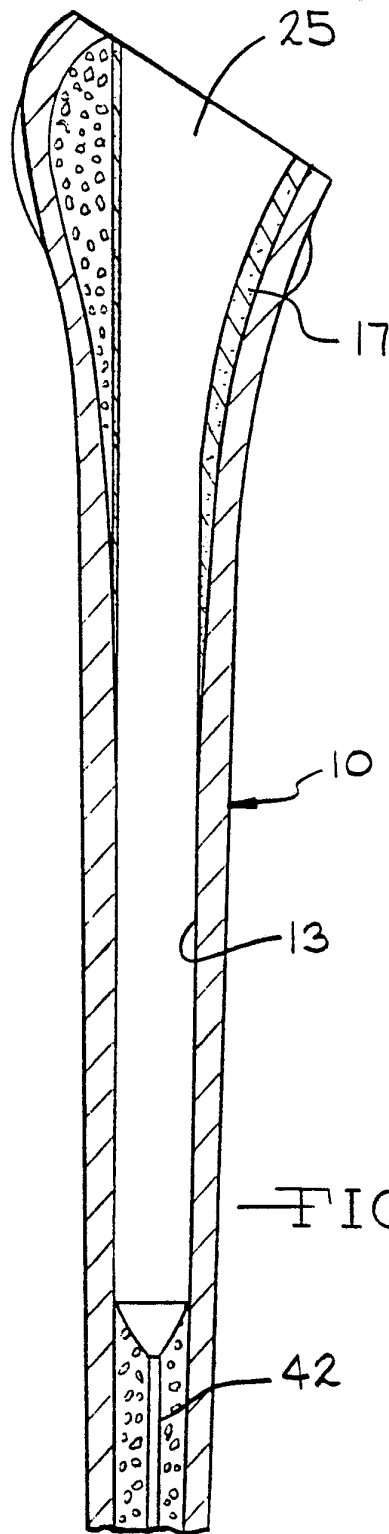

FIG. 9

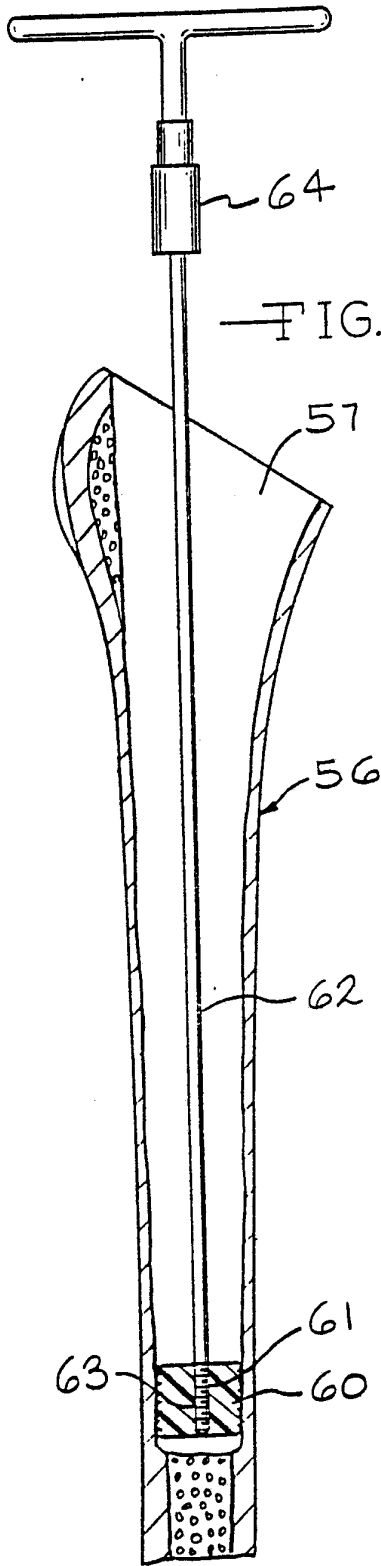

FIG. 10

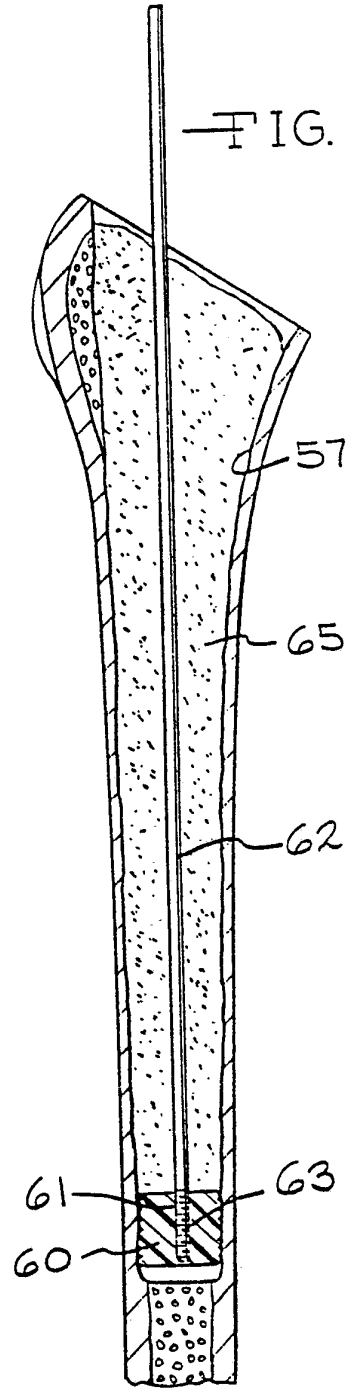

FIG. 11

SUBSTITUTE SHEET

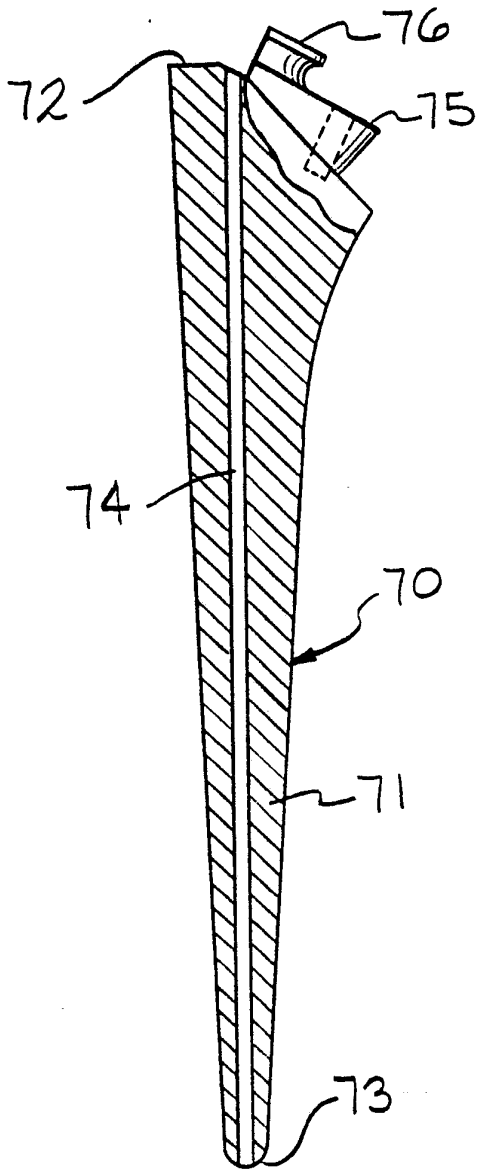

FIG. 12

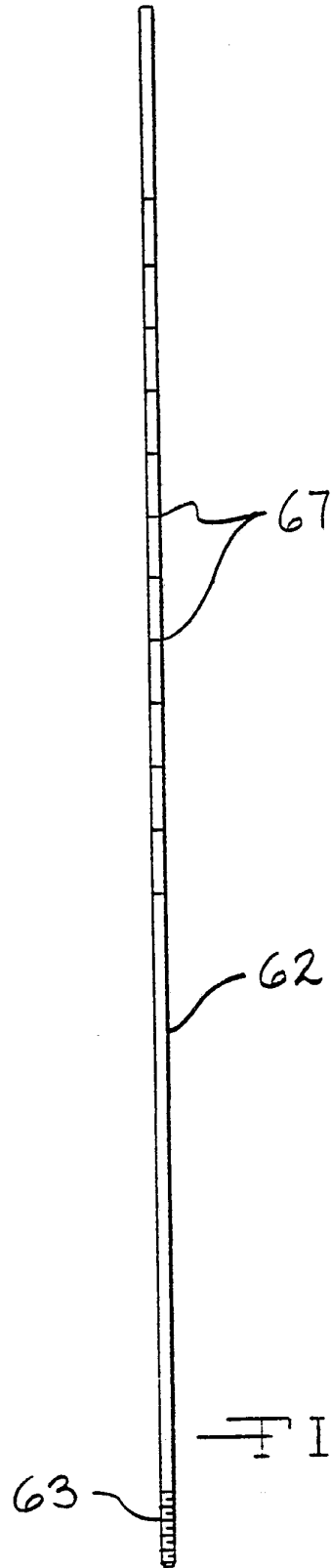

FIG. 13

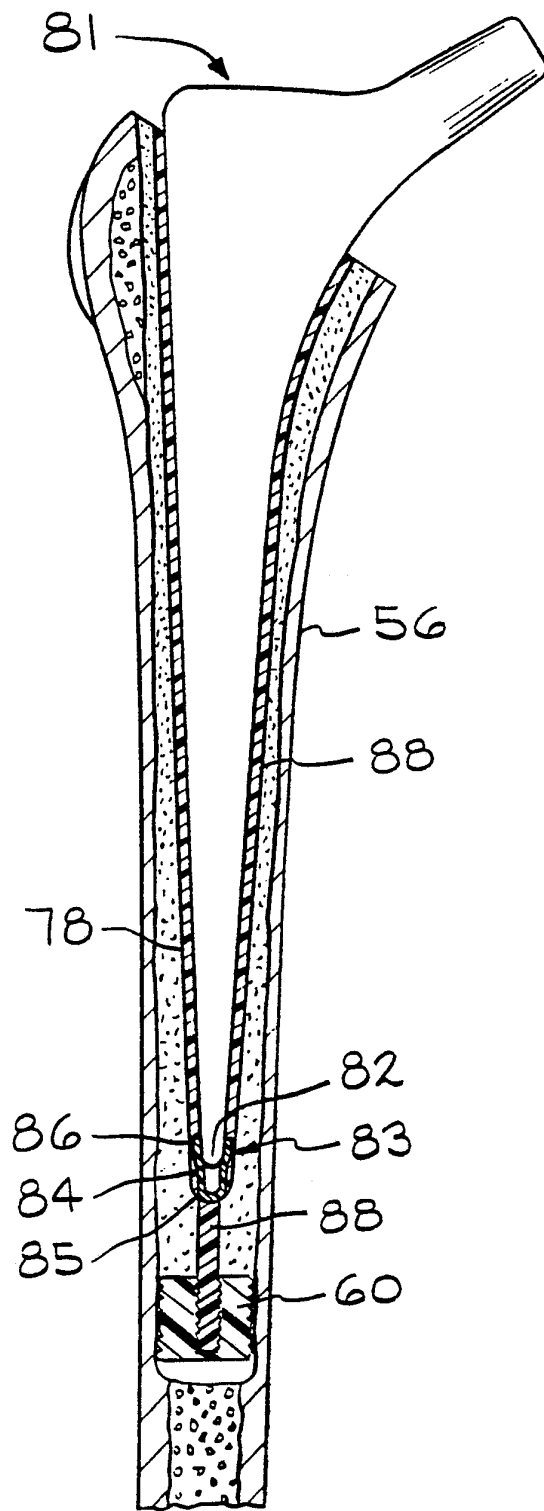
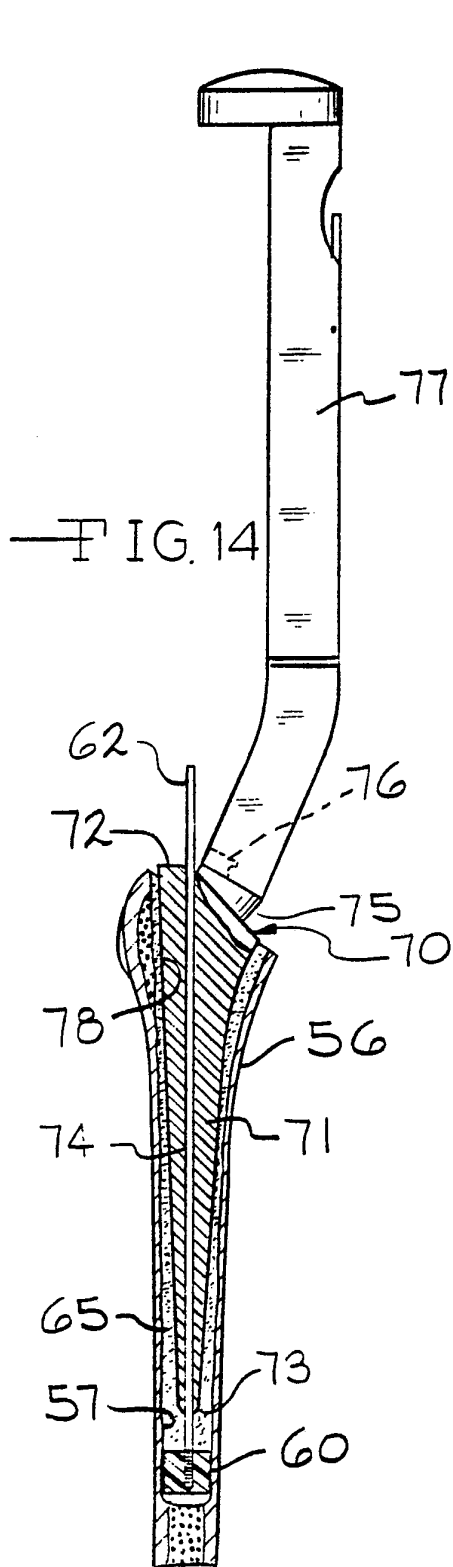

FIG. 15

INTERNATIONAL SEARCH REPORT

International application No.
PCT/US92/06039

A. CLASSIFICATION OF SUBJECT MATTER

IPC(5) :A61F 5/04
US CL :606/93

According to International Patent Classification (IPC) or to both national classification and IPC

B. FIELDS SEARCHED

Minimum documentation searched (classification system followed by classification symbols)

U.S. : 606/100 623/66,23,18

Documentation searched other than minimum documentation to the extent that such documents are included in the fields searched

Electronic data base consulted during the international search (name of data base and, where practicable, search terms used)

C. DOCUMENTS CONSIDERED TO BE RELEVANT

Category*	Citation of document, with indication, where appropriate, of the relevant passages	Relevant to claim No.
A	US,A, 4,919,153 (CHIN) 24 APRIL 1990	1-10
X	US,A, 4,919,673 (WILLERT) 24 APRIL 1990 See entire document	10

Further documents are listed in the continuation of Box C. See patent family annex.

* Special categories of cited documents:	"T" later document published after the international filing date or priority date and not in conflict with the application but cited to understand the principle or theory underlying the invention
"A" document defining the general state of the art which is not considered to be part of particular relevance	"X" document of particular relevance; the claimed invention cannot be considered novel or cannot be considered to involve an inventive step when the document is taken alone
"E" earlier document published on or after the international filing date	"Y" document of particular relevance; the claimed invention cannot be considered to involve an inventive step when the document is combined with one or more other such documents, such combination being obvious to a person skilled in the art
"L" document which may throw doubts on priority claim(s) or which is cited to establish the publication date of another citation or other special reason (as specified)	"Z" document member of the same patent family
"O" document referring to an oral disclosure, use, exhibition or other means	
"P" document published prior to the international filing date but later than the priority date claimed	

Date of the actual completion of the international search

30 SEPTEMBER 1992

Date of mailing of the international search report

12 NOV 1992

Name and mailing address of the ISA/
Commissioner of Patents and Trademarks
Box PCT
Washington, D.C. 20231

Facsimile No. NOT APPLICABLE

Authorized officer

GINA GUALTIERI

Telephone No. (703) 308-0858