



(19) **United States**

(12) **Patent Application Publication**  
**Hsieh**

(10) **Pub. No.: US 2013/0276228 A1**

(43) **Pub. Date: Oct. 24, 2013**

(54) **FRAMED BED FOUNDATION**

(52) **U.S. Cl.**

USPC ..... 5/400

(75) Inventor: **Cheng-Hsian Hsieh**, Taichung (TW)

(57) **ABSTRACT**

(73) Assignees: **ASIATEX INDUSTRIAL LTD.**,  
Taichung (TW); **Cheng-Hsian Hsieh**,  
Taichung (TW)

A bed foundation comprises a first frame body and a second frame body. The first frame body and the second frame body are connected pivotally by a middle foot stand, and two lateral foot stands are pivotally disposed under the first frame body and the second frame body. Supporting bars are disposed between the middle foot stand and the two foot lateral stands. Thereby, the bed foundation of the present invention can be folded away for convenient transporting and the smaller folded size is convenient for carrying into a house for assembling.

(21) Appl. No.: **13/452,886**

(22) Filed: **Apr. 22, 2012**

**Publication Classification**

(51) **Int. Cl.**  
**A47C 19/12** (2006.01)

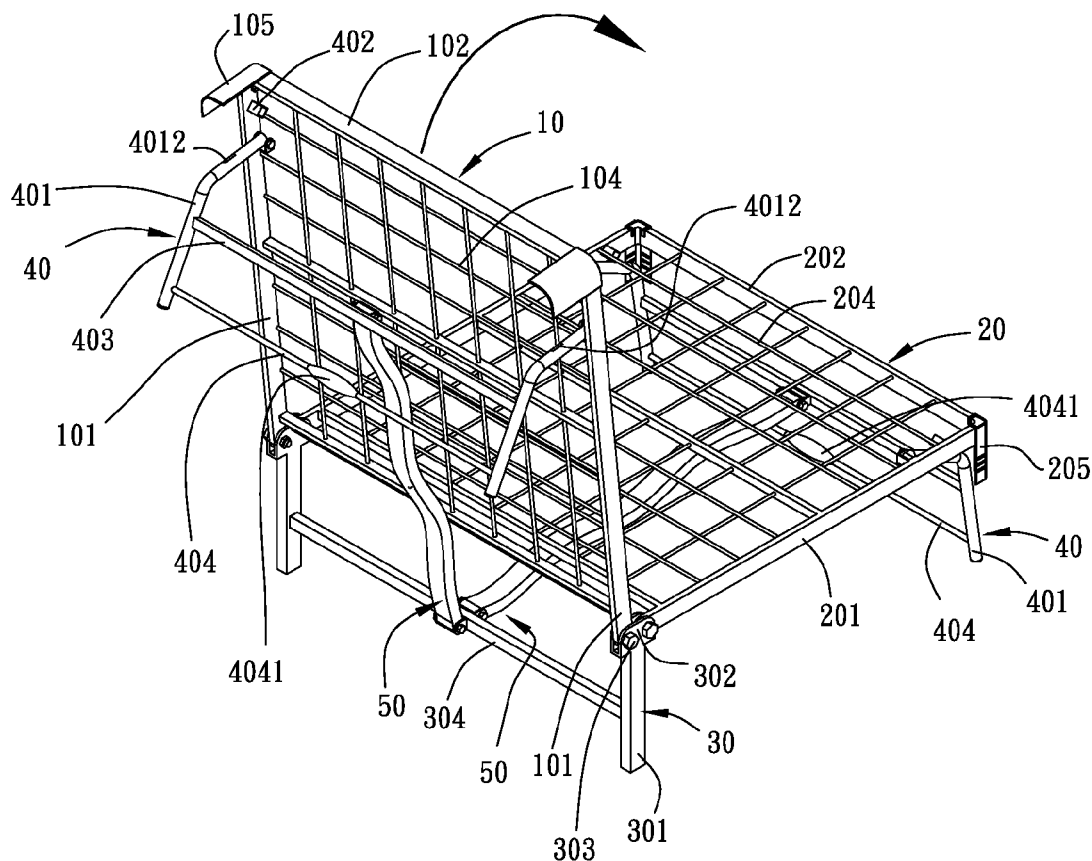

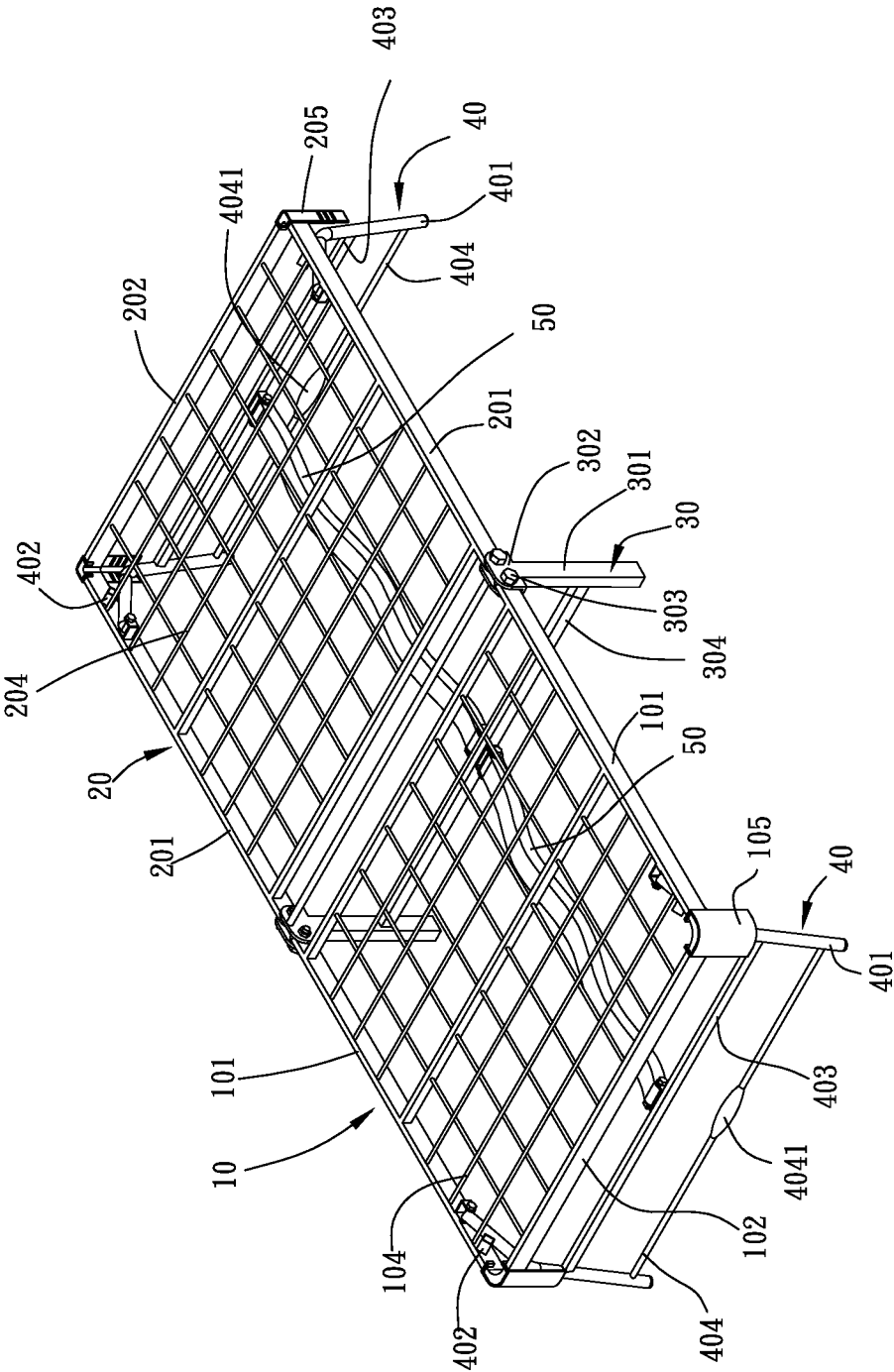

FIG. 1

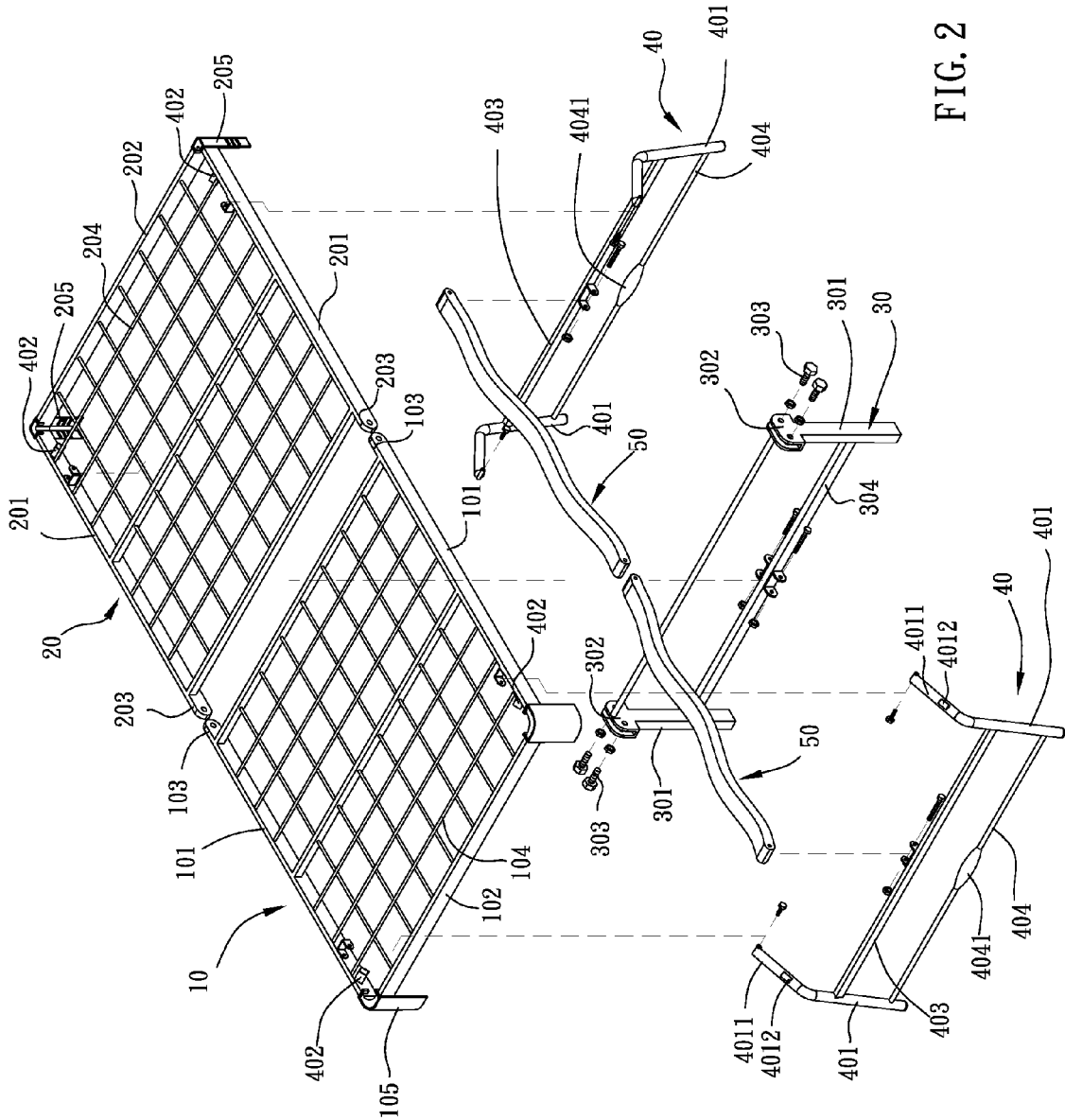

FIG. 2

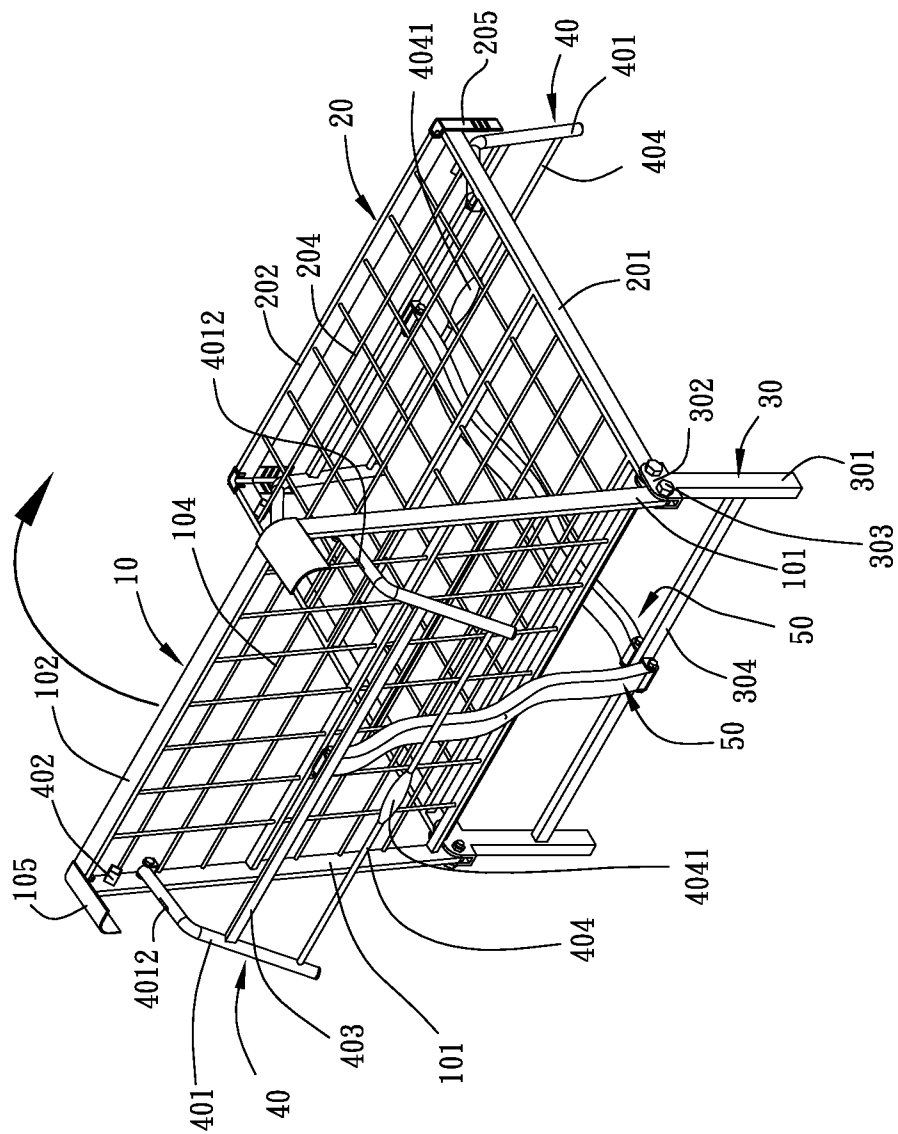

FIG 3

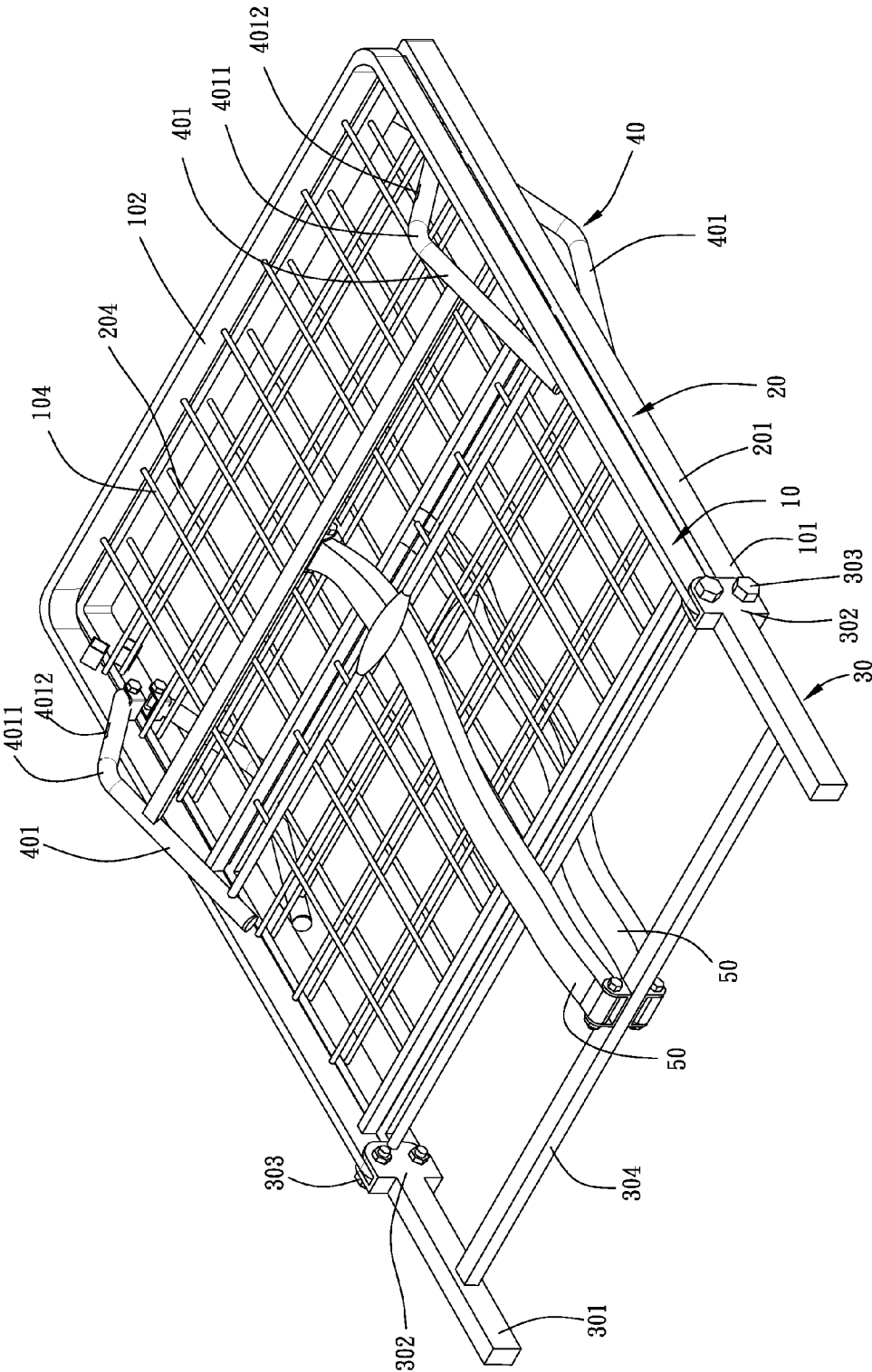

FIG. 4

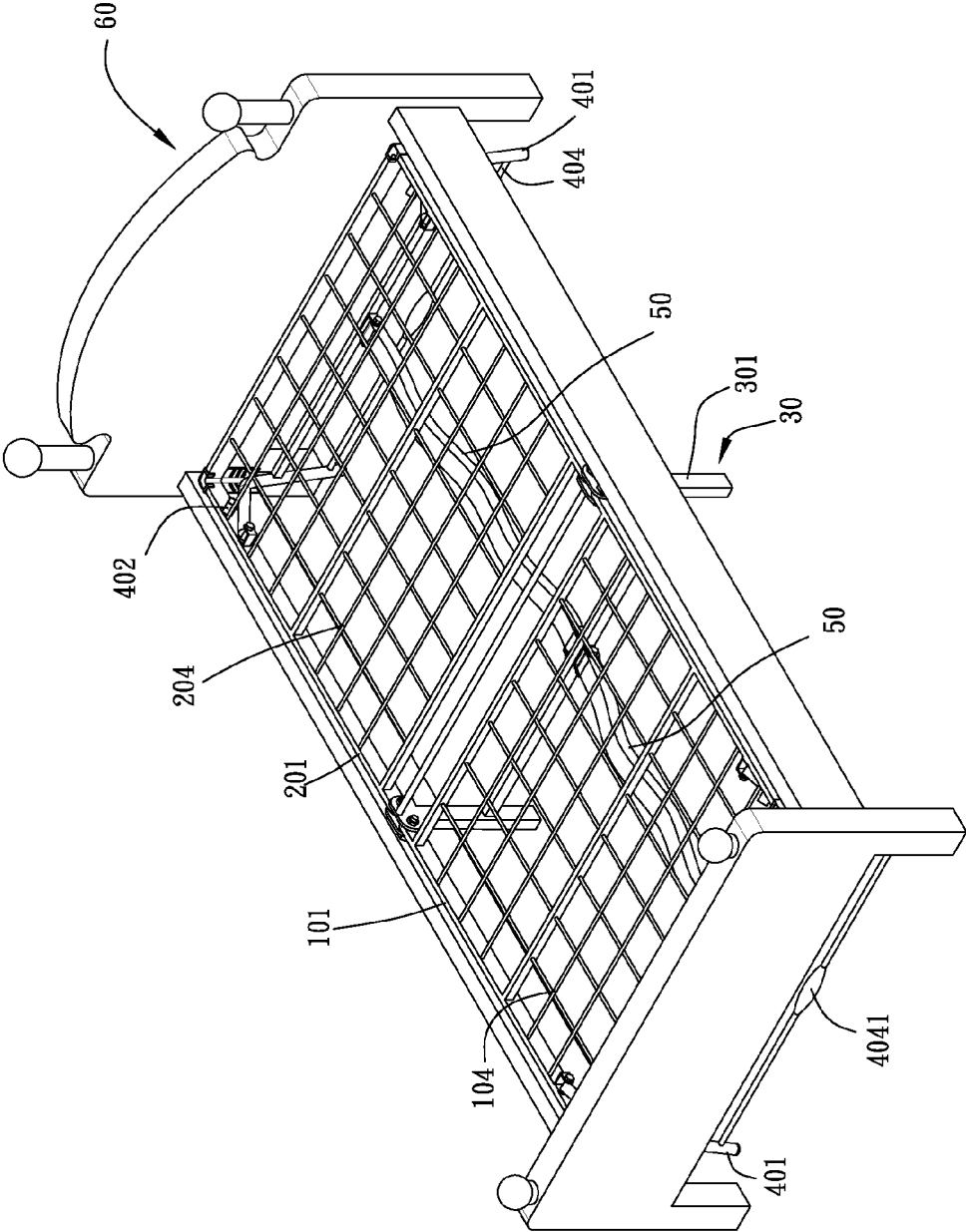

FIG. 5

**FRAMED BED FOUNDATION**

**BACKGROUND OF THE INVENTION**

**[0001]** 1. Field of Invention

**[0002]** The present invention relates to a bed foundation and more particularly to a foldable bed foundation for disposing in a bed frame. The foldable bed foundation can save space and is convenient to be unfolded for use and folded away for storage.

**[0003]** 2. Related Art

**[0004]** A common bed frame has a plurality of supporting bars disposed at the middle of the frame, and a bedplate is placed on the supporting bars so that a person can lie down on the bedplate which is supported by the supporting bars. For some bed frames, a bed foundation is placed in the middle of the frame for a person to lie on. However, a common bed foundation is not foldable and the entire bed foundation with a bulky size needs to be lifted up for transporting, which is very inconvenient. Furthermore, because the bed foundation cannot be folded away and is bulky in size, it will be inconvenient for carrying into a house for assembling.

**SUMMARY OF THE INVENTION**

**[0005]** An object of the present invention is to provide a bed foundation to solve the problems of a conventional bed foundation, which are inconvenient for carrying because the entire bed foundation needs to be lifted up and inconvenient for carrying into a house because of the bulky size.

**[0006]** In order to solve the above problems, a bed foundation provided by the present invention comprises:

**[0007]** a first frame body comprising two first lateral frames, a first transverse frame being connected to an end of each of the two first lateral frames, another end of each of the two first lateral frames being a first pivotal end, a plurality of first connecting bars being connected between the two first lateral frames;

**[0008]** a second frame body comprising two second lateral frames, a second transverse frame being connected to an end of each of the two second lateral frames, another end of each of the two second lateral frames being a second pivotal end, a plurality of second connecting bars being connected between the two second lateral frames, the two second pivotal ends being corresponded to the two first pivotal ends respectively so that the first frame body and the second frame body forming a bed surface;

**[0009]** a middle foot stand comprising two vertical stands, a pivotal foundation being disposed at a top end of each of the two vertical stands, the two pivotal foundations respectively supporting the two first pivotal ends and the two second pivotal ends correspondingly, the two first pivotal ends and the two second pivotal ends being fixed on the pivotal foundations by a plurality of fixing elements respectively, a transverse stand being connected between the two vertical stands near the lower sections; and

**[0010]** two lateral foot stands and each of the two lateral foot stands comprising two lateral stands, top ends of the two lateral stands being pivotally connected to corresponding ends of the two first lateral frames and the two second lateral frames respectively, the top ends of the two lateral stands being disposed adjacent to the first transverse frame and the second transverse frame, top sections of the two lateral stands being formed as arc portions facing towards the first transverse frame and the second transverse frame, positioning

elements corresponding to the arc portions being disposed on the two first lateral frames and the two second lateral frames so that the two lateral stands being positioned by the positioning elements, a middle supporting stand being disposed between the two lateral stands adjacent to the middle sections of the two lateral foot stands respectively.

**[0011]** According to the above structures, a first fixing piece is respectively disposed at where the two first lateral frames and the first transverse frame are connected.

**[0012]** According to the above structures, a second fixing piece is respectively disposed at where the two second lateral frames and the two second transverse frame are connected.

**[0013]** According to the above structures, a lower supporting stand is disposed between the two lateral stands adjacent to the lower sections of the two lateral foot stands respectively, and a cushion is disposed at the middle of the two lower supporting stands respectively.

**[0014]** According to the above structures, the bed foundation of the present invention further comprises two supporting bars. The two supporting bars are disposed under the first frame body and the second frame body. An end of each of the two supporting bars is pivotally connected to the middle section of the transverse stand of the middle foot stand, and another end of each of the two supporting bars is pivotally connected to the middle sections of the middle supporting stands of the two lateral foot stands respectively.

**[0015]** According to the above structures, a gasket is respectively disposed on locations of the arc portions corresponding to the positioning elements.

**[0016]** According to the above structures, the two supporting bars are roughly in wavy shape.

**[0017]** Comparing with the effects of the conventional techniques, the bed foundation provided by the present invention is foldable for convenient transporting the smaller folded size is convenient for carrying into a house for assembling.

**[0018]** The present invention will become more fully understood by reference to the following detailed description thereof when read in conjunction with the attached drawings.

**BRIEF DESCRIPTION OF THE DRAWINGS**

**[0019]** FIG. 1 is a perspective view of a bed foundation of the present invention;

**[0020]** FIG. 2 is a perspective exploded view of the bed foundation of the present invention;

**[0021]** FIG. 3 is an illustration of the movement of a first frame body of the present invention;

**[0022]** FIG. 4 is a perspective view of the first frame body and a second frame body of the present invention being folded together; and

**[0023]** FIG. 5 is a perspective view of the bed foundation of the present invention being used.

**DETAILED DESCRIPTION OF THE INVENTION**

**[0024]** Please refer to FIGS. 1 to 5 for the descriptions of a bed foundation of the present invention. The bed foundation of the present invention comprises a first frame body 10, a second frame body 20, a middle foot stand 30, two lateral foot stands 40 and two supporting bars 50. The first frame body 10 comprises two first lateral frames 101. A first transverse frame 102 is connected to an end of each of the two first lateral frames 101, and another end of each of the two first lateral frames 101 is a first pivotal end 103. A plurality of first connecting bars 104 is connected between the two first lateral

frames **101**. A first fixing piece **105** is respectively disposed at where the two first lateral frames **101** and the first transverse frame **102** are connected.

[0025] The second frame body **20** comprises two second lateral frames **201**. A second transverse frame **202** is connected to an end of each of the two second lateral frames **201**, and another end of each of the two second lateral frames **201** is a second pivotal end **203**. A plurality of second connecting bars **204** is connected between the two second lateral frames **201**. The two second pivotal ends **203** are corresponded to the two first pivotal ends **103** respectively so that the first frame body **10** and the second frame body **20** forms a bed surface. A second fixing piece **205** is respectively disposed at where the two second lateral frames **201** and the second transverse frame **202** are connected.

[0026] The middle foot stand **30** comprises two vertical stands **301**. A pivotal foundation **302** is disposed at a top end of each of the two vertical stands **301**. The two pivotal foundations **302** respectively supporting the two first pivotal ends **103** and the two second pivotal ends **203** correspondingly. The two first pivotal ends **103** and the two second pivotal ends **203** are fixed on the pivotal foundations **302** by a plurality of fixing elements **303** respectively. A transverse stand **304** is connected between the two vertical stands **301** near the lower sections.

[0027] Each of the two lateral foot stands **40** comprises two lateral stands **401**. Top ends of the two lateral stands **401** are pivotally connected to corresponding ends of the two first lateral frames **101** and the two second lateral frames **201** respectively. The top ends of the two lateral stands **401** are disposed adjacent to the first transverse frame **102** and the second transverse frame **202**. Top sections of the two lateral stands **401** are formed as arc portions **4011** facing towards the first transverse frame **102** and the second transverse frame **202**. Positioning elements **402** corresponding to the arc portions **4011** are disposed on the two first lateral frames **101** and the two second lateral frames **201** so that the two lateral stands **401** are positioned by the positioning elements **402**. A gasket **4012** is respectively disposed on locations of the arc portions **4011** corresponding to the positioning elements **402**. A middle supporting stand **403** is disposed between the two lateral stands **401** adjacent to the middle sections of the two lateral foot stands **40** respectively. A lower supporting stand **404** is disposed between the two lateral stands **401** adjacent to the lower sections of the two lateral foot stands **40** respectively, and a cushion **4041** is disposed at the middle of the two lower supporting stands **404** respectively.

[0028] The two supporting bars **50** are roughly in wavy shape. The two supporting bars **50** are disposed under the first frame body **10** and the second frame body **20**. An end of each of the two supporting bars **50** is pivotally connected to the middle section of the transverse stand **304** of the middle foot stand **30**, and another end of each of the two supporting bars **50** is pivotally connected to the middle sections of the middle supporting stands **403** of the two lateral foot stands **40** respectively.

[0029] According to the above structures and design, please refer to FIGS. **3** and **4** for the folding of the bed foundation of the present invention. The first fixing pieces **105** and the second fixing pieces **205** are taken off first. Then, the first frame body **10** is folded away towards the second frame body **20** by using the middle foot stand **30** as a pivotal point. When the first frame body **10** is folded away, the lateral foot stand **40** on the first frame body **10** can be pivotally turned towards the

first frame body **10** so that the supporting bar **50** and the lateral foot stand **40** on the first frame body **10** are folded away. When the first frame body **10** is folded away and is closed to the second frame body **20**, the middle foot stand **30** will be turned horizontally. At this point, the lateral foot stand **40** on the second frame body **20** is turned pivotally towards the second frame body **20** so that the supporting bar **50** and the lateral foot stand **40** on the second frame body **20** are folded away. Finally, the second frame body **20** and the first frame body **10** are overlapped on each other flatly.

[0030] As shown in FIG. **5**, the bed foundation of the present invention can be placed in a bed frame **60**. The bed foundation is foldable for convenient transporting and does not take up much space. Because the bed frame **60** is already in a house, all a user have to do is to carry the smaller and folded bed foundation into the house for assembling.

[0031] As a conclusion from the above, the foldable bed case is made flat after it is folded away to make the size a lot smaller for convenient transporting. The smaller size of the folded bed foundation is also convenient for carrying into a house for assembling.

[0032] Note that the specifications relating to the above embodiments should be construed as exemplary rather than as limitative of the present invention, with many variations and modifications being readily attainable by a person of average skill in the art without departing from the spirit or scope thereof as defined by the appended claims and their legal equivalents.

What is claimed is:

1. A bed foundation comprising:

- a first frame body comprising two first lateral frames, a first transverse frame being connected to an end of each of the two first lateral frames, another end of each of the two first lateral frames being a first pivotal end, a plurality of first connecting bars being connected between the two first lateral frames;
- a second frame body comprising two second lateral frames, a second transverse frame being connected to an end of each of the two second lateral frames, another end of each of the two second lateral frames being a second pivotal end, a plurality of second connecting bars being connected between the two second lateral frames, the two second pivotal ends being corresponded to the two first pivotal ends respectively so that the first frame body and the second frame body forming a bed surface;
- a middle foot stand comprising two vertical stands, a pivotal foundation being disposed at a top end of each of the two vertical stands, the two pivotal foundations respectively supporting the two first pivotal ends and the two second pivotal ends correspondingly, the two first pivotal ends and the two second pivotal ends being fixed on the pivotal foundations by a plurality of fixing elements respectively, a transverse stand being connected between the two vertical stands near the lower sections; and

two lateral foot stands and each of the two lateral foot stands comprising two lateral stands, top ends of the two lateral stands being pivotally connected to corresponding ends of the two first lateral frames and the two second lateral frames respectively, the top ends of the two lateral stands being disposed adjacent to the first transverse frame and the second transverse frame, top sections of the two lateral stands being formed as arc portions facing towards the first transverse frame and the

second transverse frame, positioning elements corresponding to the arc portions being disposed on the two first lateral frames and the two second lateral frames so that the two lateral stands being positioned by the positioning elements, a middle supporting stand being disposed between the two lateral stands adjacent to the middle sections of the two lateral foot stands respectively.

2. The bed foundation as claimed in claim 1, wherein a first fixing piece is respectively disposed at where the two first lateral frames and the first transverse frame are connected.

3. The bed foundation as claimed in claim 1, wherein a second fixing piece is respectively disposed at where the two second lateral frames and the two second transverse frame are connected.

4. The bed foundation as claimed in claim 1, wherein a lower supporting stand is disposed between the two lateral stands adjacent to the lower sections of the two lateral foot

stands respectively, and a cushion is disposed at the middle of the two lower supporting stands respectively.

5. The bed foundation as claimed in claim 1, wherein the bed foundation further comprises two supporting bars, the two supporting bars are disposed under the first frame body and the second frame body, an end of each of the two supporting bars is pivotally connected to the middle section of the transverse stand of the middle foot stand, and another end of each of the two supporting bars is pivotally connected to the middle sections of the middle supporting stands of the two lateral foot stands respectively.

6. The bed foundation as claimed in claim 1, wherein a gasket is respectively disposed on locations of the arc portions corresponding to the positioning elements.

7. The bed foundation as claimed in claim 5, wherein the two supporting bars are roughly in wavy shape.

\* \* \* \* \*