

(No Model.)

C. & G. SPENGLER.
COMBINED LATCH AND KNOB.

No. 527,627.

Patented Oct. 16, 1894.

Fig. 1.

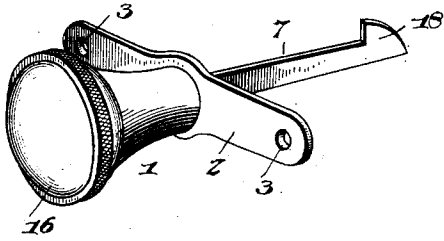

Fig. 3.

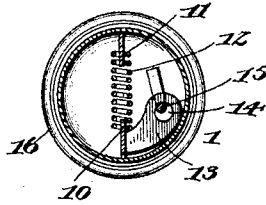

Fig. 2.

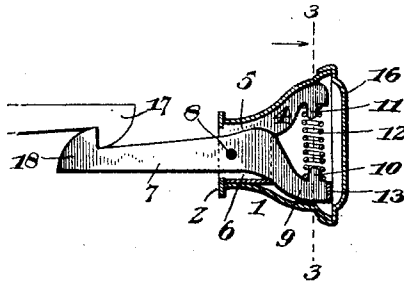

Fig. 4.

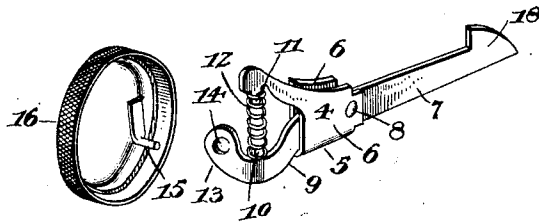
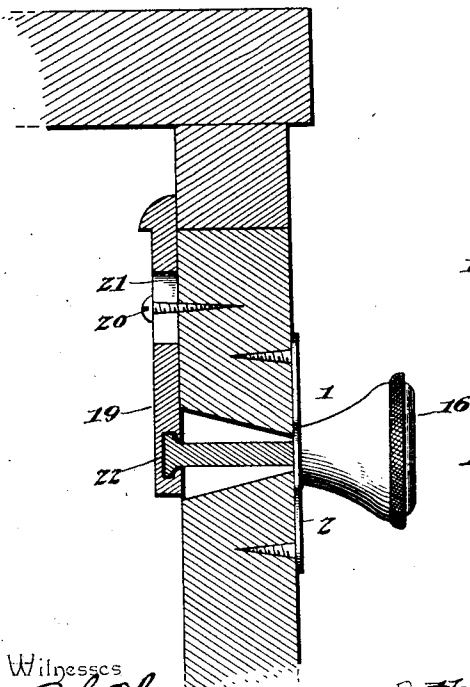

Fig. 5.



Witnesses

B. Ober
[Signature]

Inventors:
Charles Spengler,
George Spengler,

By *their* Attorneys.

Calhoun & Co.

UNITED STATES PATENT OFFICE.

CHARLES SPENGLER AND GEORGE SPENGLER, OF ROCKFORD, ILLINOIS.

COMBINED LATCH AND KNOB.

SPECIFICATION forming part of Letters Patent No. 527,627, dated October 16, 1894.

Application filed June 14, 1894. Serial No. 514,573. (No model.)

To all whom it may concern:

Be it known that we, CHARLES SPENGLER and GEORGE SPENGLER, citizens of the United States, residing at Rockford, in the county of Winnebago and State of Illinois, have invented a new and useful Combined Catch and Knob, of which the following is a specification.

Our invention relates to a spring catch for use in connection with show-cases, drawers, doors, and other closures, the object in view being to provide a device capable of automatic engagement, and adapted to be disengaged by a manipulation of a knob or a part of a knob used in connection with and forming a part of the catch, and with this object in view the invention consists in a certain novel construction, combination and arrangement of parts which will be more fully described hereinafter, and the novel features of which will be particularly pointed out in the appended claims.

In the drawings:—Figure 1 is a perspective view of a catch embodying our invention. Fig. 2 is a central section of the same. Fig. 3 is a transverse section on the line 3—3 of Fig. 2. Fig. 4 is a detail view in perspective of the latch and attachments including the rotatable cap, the latter being detached from the latch. Fig. 5 is a view of a slightly modified form of the catch adapted for use in connection with drawers.

Similar numerals of reference indicate corresponding parts in all the figures of the drawings.

1 designates a casing forming a part of a securing-plate 2 having perforations 3, through which may be passed suitable screws for securing the plate to the object in connection with which the improved catch is used, and within this casing is secured a bracket 4, preferably provided with a guide 5 having parallel plates 6. Between these guide-plates is arranged a latch 7, which is mounted upon a transverse pivot-pin 8, and this latch is provided with an upper arm 9 having a stud 10 which is arranged opposite a similar stud 11 at the upper end of the said bracket, a coiled spring 12 being engaged at its terminals with these studs in order to hold the latch normally in its locking position. The upper arm of the latch is further provided with a lateral projection 13 having a terminal per-

foration 14, with which is engaged a depending pin 15 on the rotatable cap 16, said cap being mounted upon and closing the upper or outer side of the casing, and with said casing forming the knob.

It will be seen that when the cap is turned its motion is communicated by means of the depending pin to the projection on the upper arm of the latch, whereby said latch is moved in opposition to the tension of the actuating spring. A suitable shouldered hasp 17 is used in connection with the above described latch, said latch being provided with a shouldered bolt-head 18, as shown in Figs. 1 to 4, or being connected to a bolt 19, as shown in Fig. 5 when the device is to be used in connection with a drawer or other construction. In said modified construction the bolt 19 is mounted for sliding by means of a guide-screw 20 and an engaging slot 21, a loose connection 22 being provided between the latch and the bolt.

The advantage of the above description resides in the fact that the latch may be disengaged by a rotary movement of the hand which grasps the knob to open the door, drawer, or other closure, thus obviating the necessity of using both hands for the purpose. It will be understood, furthermore, that in practice various changes in the form, proportion, and the minor details of construction may be resorted to without departing from the spirit of the invention or sacrificing any of the advantages thereof.

Having described our invention, what we claim is—

1. In a device of the class described, the combination of a knob comprising a hollow casing, and a rotatable cap fitted thereon, a latch arranged at one end within the casing, and connections between the latch and the rotatable cap, substantially as specified.

2. In a device of the class described, the combination of a knob having a hollow casing, and a cap rotatably mounted thereon, a pivotal latch arranged at one end of the casing, a spring for normally holding the latch in its operative position, and connections between the latch and the rotatable cap, substantially as specified.

3. In a device of the class described, the combination of a knob having a hollow casing, and a cap rotatably mounted thereon, a

pivotal latch arranged at one end within the casing, a spring for holding the latch in its operative position, and a pin carried by the cap and engaging a projection on the latch
5 whereby motion is communicated from the cap to the latch, substantially as specified.

4. In a device of the class described, the combination of a knob having a hollow casing, and a cap rotatably mounted thereon, a
10 pivotal latch arranged at one end in the casing and provided with a terminal projection having a perforation, and a pin carried by the cap and engaging said perforation, substantially as specified.

15 5. In a device of the class described, the combination of a knob having a hollow casing, and a cap rotatably mounted thereon, a bracket arranged within the casing and provided with a stud, of a latch pivotally con-
20 nected to the bracket and provided with a corresponding stud, a coiled spring engaged

terminally with said studs, and connections between the rotatable cap and the latch, substantially as specified.

6. In a device of the class described, the
25 combination of a knob having a hollow casing, and a cap rotatably fitted thereon, a bracket arranged within the casing and having parallel guide-plates, a latch pivotally arranged between said guide-plates, an actu-
30 ating spring interposed between the bracket and the inner arm of the latch, and connections between the rotatable cap and the latch, substantially as specified.

In testimony that we claim the foregoing
35 as our own we have hereto affixed our signatures in the presence of two witnesses.

CHARLES SPENGLER.

GEORGE SPENGLER.

Witnesses:

NELS THORSLEGE,

ALFRED MOSER.