



(11) **EP 4 079 184 A1**

(12) **EUROPEAN PATENT APPLICATION**

(43) Date of publication:
26.10.2022 Bulletin 2022/43

(51) International Patent Classification (IPC):
A45C 7/00 (2006.01) A45C 11/20 (2006.01)

(21) Application number: **22168009.3**

(52) Cooperative Patent Classification (CPC):
A45C 7/0077; A45C 11/20

(22) Date of filing: **12.04.2022**

(84) Designated Contracting States:
AL AT BE BG CH CY CZ DE DK EE ES FI FR GB GR HR HU IE IS IT LI LT LU LV MC MK MT NL NO PL PT RO RS SE SI SK SM TR
Designated Extension States:
BA ME
Designated Validation States:
KH MA MD TN

- **Hardy, Lindsey Katy, 77494 (US)**
- **Bodziak, Haley Katy, 77494 (US)**
- **Urbano, Stacey Katy, 77494 (US)**

(30) Priority: **21.04.2021 US 202163177626 P**

(71) Applicant: **Igloo Products Corp. Katy, TX 77494 (US)**

(74) Representative: **Grosse, Felix Christopher Grosse - Schumacher - Knauer - von Hirschhausen Patent- und Rechtsanwälte Nymphenburger Straße 14 80335 München (DE)**

(72) Inventors:

- **Gamboa, Grace Anne Katy, 77494 (US)**

(54) **PACKABLE COOLER BAG**

(57) A packable cooler bag 100 comprises a cooler bag having a first sidewall and a second sidewall defining an outer shell 115 of said cooler bag, wherein said outer shell 115 has an opening to access an interior of the cooler bag, a pocket being disposed on an exterior of said cooler bag, said cooler bag and said pocket having a packed configuration wherein said cooler bag is in-side said pocket and an unpacked configuration wherein said cooler bag is unpacked from within the pocket, and a reversible panel 103 being disposed on said outer shell 115 and defining a portion of said pocket. Said cooler bag is packable from the unpacked configuration by reversibly pulling said cooler bag into the pocket so that the cooler bag is retained inside the pocket in the packed configuration.

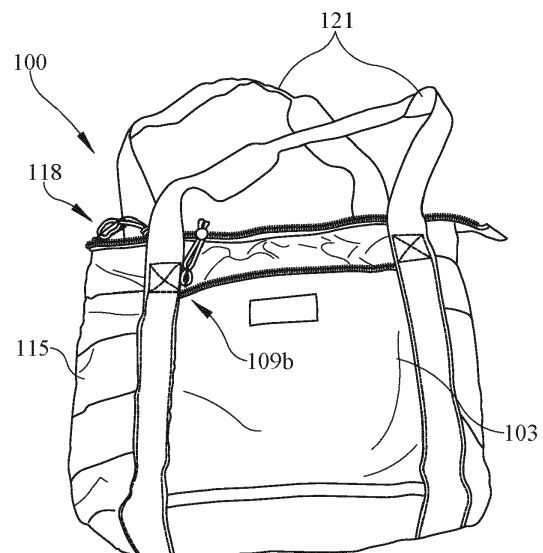

FIG. 1B

EP 4 079 184 A1

Description

[0001] The present invention relates generally to coolers, and more particularly, to a packable cooler bag.

[0002] According to some embodiments, a packable cooler bag may comprise a cooler bag, a first sidewall and a second sidewall defining an outer shell of the cooler bag, the outer shell having an opening to access an interior of the cooler bag, a pocket disposed on an exterior of the cooler bag, the cooler and pocket having a packed configuration wherein the cooler bag is inside the pocket and an unpacked configuration wherein the cooler bag is unpacked from within the pocket, and, a reversible panel disposed on the outer shell and defining a portion of the pocket, wherein the cooler bag is packable from the unpacked configuration by reversibly pulling the cooler bag into the pocket so that the bag is retained inside the pocket in the packed configuration.

[0003] According to some optional embodiments, the following features may be used alone with the packable cooler bag, or in combination with other features and the packable cooler bag. In some embodiments, the reversible panel may be a portion of the pocket in the unpacked configuration. The pocket may be disposed on the exterior of the cooler bag in the unpacked configuration. The reversible panel may be reversed in the packed configuration from the unpacked configuration and forms a portion of the pocket. The pocket may contain the cooler bag in the packed configuration. The reversible panel may be connected to the cooler bag along three sides of the reversible panel. A bottom side of the three sides of the reversible panel is disposed adjacent to a bottom of the outer shell. The packable cooler bag may further comprise a reversible zipper to open and close the pocket. The packable cooler bag may further comprise an insulating material disposed within the outer shell. The reversible panel may be uninsulated or insulated. The cooler bag may further comprise at least one strap. The pocket may be sized to contain the cooler bag when the cooler bag is compressed.

[0004] In some embodiments, a method for unpacking a packable cooler bag comprises the steps of providing a pocket with cooler bag in a packed configuration within the pocket, unfastening a reversible zipper of the pocket in the packed configuration, reversing a reversible panel defining a portion of the pocket and removing the cooler bag from within the pocket, and, obtaining a top closure for the cooler bag in the unpacked configuration.

[0005] According to some optional embodiments, the following features may be used alone with the method, or in combination with other features and the method. The method further comprising obtaining one or more carrying straps of the cooler bag. The method further comprising fastening the reversible zipper assembly to close the pocket.

[0006] In some embodiments, a method for packing a packable cooler comprises the steps of providing a cooler bag in an unpacked configuration with a reversible panel

on an outer shell of the cooler bag and defining a portion of a pocket, unfastening a reversible zipper of the pocket, grasping an internal area of the pocket and pulling the cooler bag into the internal portion of the pocket as the pocket reverses inside to outside, and packing any remaining portion of the cooler bag into the pocket which is reversed.

[0007] According to some optional embodiments, the following features may be used alone with the method, or in combination with other features and the method. The method may further comprise the step of fastening a reversible zipper assembly when the cooler bag is in a packed configuration within the pocket. The method may further comprise compressing the cooler bag while the pulling the cooler bag into the internal portion of the pocket occurs.

[0008] The accompanying drawings illustrate only example embodiments of a packable cooler bag and method and therefore are not to be considered limiting of the scope of this invention. The principles illustrated in the example embodiments of the drawings can be applied to alternate methods and apparatus. Additionally, the elements and features shown in the drawings are not necessarily to scale, emphasis instead being placed upon clearly illustrating the principles of the example embodiments. Certain dimensions or positions may be exaggerated to help visually convey such principles. In the drawings, the same reference numerals used in different embodiments designate like or corresponding, but not necessarily identical, elements, wherein:

Figs. 1A and 1B show a packable cooler bag in accordance with an example embodiment of the invention;

Fig. 2A is a front view of the packable cooler bag in a packed configuration in accordance with an example embodiment of the invention;

Fig. 2B is a rear view of the packable cooler bag in the packed configuration in accordance with an example embodiment of the invention;

Fig. 2C is a top view of the packable cooler bag in the packed configuration in accordance with an example embodiment of the invention;

Fig. 2D is a bottom view of the packable cooler bag in the packed configuration in accordance with an example embodiment of the invention;

Fig. 3A is a front view of the packable cooler bag in accordance with an example embodiment of the invention;

- Fig. 3B is a rear view of the packable cooler bag in accordance with an example embodiment of the invention;
- Fig. 3C is a top perspective view of the packable cooler bag in accordance with an example embodiment of the invention;
- Fig. 3D is a perspective view of the packable cooler bag in accordance with an example embodiment of the invention;
- Fig. 3E is a front view of the packable cooler bag in an unpacked configuration in accordance with an example embodiment of the invention;
- Fig. 3F is a rear view of the packable cooler bag in the unpacked configuration in accordance with an example embodiment of the invention;
- Fig. 3G is a top view of a top closure, an inner liner and a storage cavity of the packable cooler bag in accordance with an example embodiment of the invention;
- Fig. 3H is a front perspective view of the packable cooler bag in the unpacked configuration in accordance with an example embodiment of the invention;
- Fig. 3I is a bottom view of the packable cooler bag in the unpacked configuration in accordance with an example embodiment of the invention;
- Fig. 3J shows a reversible zipper assembly of the packable cooler bag in accordance with an example embodiment of the invention; and
- Fig. 3K is a top perspective view of the reversible zipper assembly of the packable cooler bag in accordance with an example embodiment of the invention.

[0009] The example embodiments discussed herein are directed to a packable cooler bag. The disclosed packable cooler bag includes a pocket that can be packed to save space. For example, carrying straps, a top closure, and other features of the cooler bag can be packed into the pocket when a packed configuration for the cooler may be preferred. The packable cooler bag can also in-

clude an inner liner and one or more openings for storage or insulation purposes. The one or more openings can be of suitable size and shape to allow cans or other items to be placed in a storage cavity defined at least in part by the liner.

[0010] In the following paragraphs, particular embodiments will be described in further detail by way of example with reference to the drawings. In the description, well-known components, methods, and/or processing techniques are omitted or briefly described. Furthermore, reference to various feature(s) of the embodiments is not to suggest that all embodiments must include the referenced feature(s).

[0011] Figs. 1A and 1B show a packable cooler bag 100 in accordance with example embodiments of the invention. The packable cooler bag 100 can include a reversible panel 103, a pocket closure 106, and a releasable attachment 112 for releasably attaching the packable cooler bag 100 for storage, carrying, and the like. The releasable attachment 112 can comprise a cord and a carabiner as shown in Fig. 1A. In some examples, the present invention describes that the packable cooler bag 100 can be packed into itself.

[0012] Fig. 1A shows the packable cooler bag 100 can be in a packed configuration, for example where features of the packable cooler bag 100 can be packed into a pocket defined by at least a portion of the reversible panel 103. The pocket can also be described as a packable pocket. The reversible panel 103 shown in Fig. 1A includes a first side comprising a region adapted for content to be printed thereon. The reversible panel 103 is attached to an outer shell 115 (Fig. 1B). The outer shell 115 and the reversible panel 103 can be formed from any suitable material including nylon fabric, polyester fabric, or a nylon/polyester blend fabric. The outer shell 115 and the reversible panel 103 can be formed from multiple sheets of fabric. Some examples of the present invention involve the reversible panel 103 being attached to the outer shell 115 and forming the pocket without being removably attached to the outer shell.

[0013] The pocket closure 106 can be attached to the reversible panel 103 and adapted for substantially closing one or more pockets of the packable cooler bag 100. The pocket closure 106 can include a reversible zipper assembly 109, comprising for example a first zipper 109a (Fig. 1A) and a second zipper 109b (Fig. 1B). The first zipper 109a can be adapted to substantially close the pocket defined by the portion of the reversible panel 103, as shown in Fig. 1A. The second zipper 109b can be associated with an unpacked configuration, as will be discussed in further detail below.

[0014] Fig. 1B shows the packable cooler bag 100 can include the outer shell 115, a top closure 118, and one or more carrying straps 121. The packable cooler bag 100 is shown in Fig. 1B in an unpacked configuration, for example where the top closure 118 provides access to one or more openings for storage or insulation purposes. The reversible panel 103 depicted in Fig. 1B shows a

second side of the reversible panel 103. The second side can include a logo patch. The reversible panel 103 can be attached to the outer shell 115 at or near one or more edges of the reversible panel 103, for example, near three edges as shown in Fig. 1B. Fig. 1B also depicts the second zipper 109b of the reversible zipper assembly 109. The outer shell 115 and the first side of the reversible panel 103 can form a pocket for additional storage, including for additional storage while items are stored in a storage cavity of the packable cooler bag 100. As depicted in Fig. 1B, the pocket for additional storage can be positioned in a central location on the outside of the outer shell 115. The pocket can for example be positioned between the one or more carrying straps 121. Figs. 1A and 1B depict that the reversible panel 103 can be reversed to cause the pocket for additional storage (Fig. 1B) associated with the first side of the reversible panel 103 (Fig. 1A) to cease to be formed and to cause a packable pocket (Fig. 1A) associated with the second side of the reversible panel 103 (Fig. 1B) to be formed.

[0015] The packable cooler bag 100 is adapted to be in a packed configuration, an unpacked configuration, and various other configurations. In examples with reference to Figs. 1A and 1B, the present invention includes a method for unpacking the packable cooler bag 100. The method includes unfastening the reversible zipper assembly 109 (for example, the first zipper 109a), reversing the reversible panel 103, and obtaining the top closure 118 and the one or more carrying straps 121 for the unpacked configuration shown in Fig. 1B. The method can also include fastening the second zipper 109b of the reversible zipper assembly 109 to substantially close the pocket for additional storage in the unpacked configuration or unfastening the second zipper 109b to access items stored in the pocket for additional storage.

[0016] Another example method includes a method for packing the packable cooler bag 100. The method includes packing the top closure 118 and the one or more carrying straps 121 into a pocket defined by at least a portion of the reversible panel 103 and the outer shell 115, and fastening the reversible zipper assembly 109 (for example, the first zipper 109a) for the packed configuration shown in Fig. 1A. In some other examples, the one or more carrying straps 121 are optional.

[0017] Referring to Figs. 2A-3K, the packable cooler bag 100 can include the reversible panel 103, the pocket closure 106, the first zipper 109a and the second zipper 109b of the reversible zipper assembly 109, the releasable attachment 112, the outer shell 115, the top closure 118, the one or more carrying straps 121, and an inner liner 124. The inner liner 124 can be adapted to be disposed between the outer shell 115 and a storage cavity 127 that is defined at least in part by the inner liner 124. In the unpacked configuration, one or more openings can extend through the outer shell 115, the inner liner 124, and the top closure 118 allowing cans or other items to be stored in the storage cavity 127.

[0018] Figs. 2A-2D show various views of the packable

cooler bag 100 in the packed configuration. Figs. 2A and 2B show a front view and a rear view of the packable cooler bag 100, respectively. The reversible panel 103 (Fig. 2A) is attached near three edges of the reversible panel 103 to the outer shell 115 (Fig. 2B) forming a pocket in which various features of the packable cooler bag 100 can be packed. The outer shell 115 can include a plurality of regions for holding material such as polyethylene foam, some other foam, or other insulating material such as a compressible insulating material, which allows packing of the cooler bag 100. Fig. 2B shows the regions for holding insulating material can include seams such as those created by stitching, welding, or fusing. Additionally, the reversible panel 103 may or may not be insulated in these embodiments.

[0019] Figs. 3A-3K show various views of the packable cooler bag 100. Fig. 3A depicts the first zipper 109a is associated with the first side of the reversible panel 103. The first zipper 109a can be unfastened for removing the one or more carrying straps 121 and the top closure 118 from the packed configuration of the packable cooler bag 100. The outer shell 115 can comprise an unpacked portion and a packed portion. The unpacked portion can be associated with the reversible panel 103 being attached to the outer shell 115 near one or more edges of the reversible panel 103. The packed portion can be packed into the pocket defined by the reversible panel 103 being attached to the outer shell 115 near the one or more edges of the reversible panel 103.

[0020] In operation, the reversible panel 103 can be reversed for the packable cooler bag 100 to enter the packed configuration, the unpacked configuration, or various other configurations. Figs. 3A and 3B show the first zipper 109a has been unfastened, and the top closure 118 and the one or more carrying straps 121 have been removed from the packed configuration of the packable cooler bag 100. In Fig. 3B, the second zipper 109b is unfastened.

[0021] Fig. 3D is a view of the packable cooler bag 100 in one of many configurations. In some examples of the packable cooler bag 100, the reversible panel 103 can be reversed for the first side of the reversible panel 103 to define a pocket that is exterior to the storage cavity 127. In Fig. 3D, the first side of the reversible panel 103 is shown with the region adapted for content. The first side of the reversible panel 103 (or at least a portion of the first side of the reversible panel 103) defines a pocket that is exterior to the storage cavity 127 of the packable cooler bag 100. The reversible zipper assembly 109 is adapted for the first zipper 109a to be stored in the pocket when the second zipper 109b is fastened. The second zipper 109b can be fastened to substantially close the pocket. The top closure 118 in Fig. 3D is shown as fastened. The top closure 118 can include a pull tab.

[0022] Figs. 3E and 3F show views of the packable cooler bag 100 in an unpacked configuration. The one or more carrying straps 121 of the packable cooler bag 100 can be attached to the outer shell 115, or attached

to the outer shell 115 and the reversible panel 103. The carrying strap(s) 121 can be attached along a front side of the outer shell 115 as shown in Fig. 3E or along a rear side of the outer shell 115 as shown in Fig. 3F. In Figs. 3E and 3F, there are two carrying straps 121 attached along the front side and the rear side of the outer shell 115. In some examples, the carrying straps 121 extend around the outer shell 115 and the inner liner 124 for carrying the packable cooler bag 100.

[0023] Fig. 3G is a top view of the top closure 118, the inner liner 124 and the storage cavity 127 of the packable cooler bag 100. The top closure 118 is unfastened and an opening extends through the outer shell 115, the top closure 118, and the inner liner 124 allowing cans or other items to be stored in the storage cavity 127. The inner liner 124 can be attached to the outer shell 115 or the top closure 118, or the outer shell 115 and the top closure 118. In some examples, the inner liner 124 can be stitched along a circumference of a top of the outer shell 115.

[0024] Fig. 3H is a front perspective view of the packable cooler bag 100 showing the reversible panel 103, the second zipper 109b, the outer shell 115, the top closure 118, the one or more carrying straps 121, and the inner liner 124, among other things. The inner liner 124 can be formed from a single sheet of antimicrobial, insulated, or leak-resistant liner, or a similar liner. Fig. 3I is a bottom view of the packable cooler bag 100 in the unpacked configuration. Ends of the carrying straps 121 can be stitched or otherwise attached together at a base of the packable cooler bag 100. Regions of the outer shell 115 for holding insulating material can extend perpendicular to the carrying straps 121.

[0025] Moving on to Fig. 3J, the reversible zipper assembly 109 of the packable cooler bag 100 is shown. In the unpacked configuration of the packable cooler bag 100, a pocket can be formed by the outer shell 115 (Fig. 3J) and the first side of the reversible panel 103 (for example, Figs. 3A and 3D). As shown in Figs. 3E, 3H, and 3J, when in the unpacked configuration, the pocket is centrally located on an exterior side of the packable cooler bag 100 with the opening of the pocket offset from the top closure 118. The central location of the pocket allows for easy storage of items in the pocket when the packable cooler bag 100 is in the unpacked configuration. The central location of the pocket also facilitates packing the packable cooler bag 100 into the pocket when transitioning from the unpacked configuration to the packed configuration. The pocket is sealed along three sides and the second zipper 109b of the reversible zipper assembly 109 can be fastened to substantially close and open the pocket.

[0026] Fig. 3K is a top perspective view of the reversible zipper assembly 109 of the packable cooler bag 100. As depicted, the first zipper 109a is adapted to substantially close the pocket defined by the reversible panel 103. The reversible zipper assembly 109 is adapted for the second zipper 109b to be stored in the pocket when

the first zipper 109a is fastened.

[0027] For any figure shown and described herein, one or more of the components may be omitted, added, repeated, and/or substituted. Accordingly, embodiments shown in a particular figure should not be considered limited to the specific arrangements of components shown in such figure. Further, if a component of a figure is described but not expressly shown or labeled in that figure, the label used for a corresponding component in another figure can be inferred to that component. Conversely, if a component in a figure is labeled but not described, the description for such component can be substantially the same as the description for the corresponding component in another figure.

[0028] With respect to the example methods described herein, it should be understood that in alternate embodiments, certain steps of the methods may be performed in a different order, may be performed in parallel, or may be omitted. Moreover, in alternate embodiments additional steps may be added to the example methods described herein. Accordingly, the example methods provided herein should be viewed as illustrative and not limiting of the invention.

[0029] Terms such as "first", "second", "top", "bottom", "side", "distal", "proximal", and "within" are used merely to distinguish one component (or part of a component or state of a component) from another. Such terms are not meant to denote a preference or a particular orientation, and are not meant to limit the embodiments described herein. In the example embodiments described herein, numerous specific details are set forth in order to provide a more thorough understanding of the invention. However, it will be apparent to one of ordinary skill in the art that the invention may be practiced without these specific details. In other instances, well-known features have not been described in detail to avoid unnecessarily complicating the description.

[0030] The terms "a," "an," and "the" are intended to include plural alternatives, for example, at least one. The terms "including", "with", and "having", as used herein, are defined as comprising (that means, open language), unless specified otherwise.

[0031] Various numerical ranges are disclosed herein. When the Applicant discloses or claims a range of any type, the Applicant's intent is to disclose or claim individually each possible number that such a range could reasonably encompass, including end points of the range as well as any sub-ranges and combinations of sub-ranges encompassed therein, unless otherwise specified. Numerical end points of ranges disclosed herein are approximate, unless excluded by proviso.

[0032] Values, ranges, or features may be expressed herein as "about", from "about" one particular value, and/or to "about" another particular value. When such values, or ranges are expressed, other embodiments disclosed include the specific value recited, from the one particular value, and/or to the other particular value. Similarly, when values are expressed as approximations, by

use of the antecedent "about," it will be understood that the particular value forms another embodiment. It will be further understood that there are a number of values disclosed therein, and that each value is also herein disclosed as "about" that particular value in addition to the value itself. In another aspect, use of the term "about" means $\pm 20\%$ of the stated value, $\pm 15\%$ of the stated value, $\pm 10\%$ of the stated value, $\pm 5\%$ of the stated value, $\pm 3\%$ of the stated value, or $\pm 1\%$ of the stated value.

[0033] Although embodiments described herein are made with reference to example embodiments, it should be appreciated by those skilled in the art that various modifications are well within the scope of this invention. Those skilled in the art will appreciate that the example embodiments described herein are not limited to any specifically discussed application and that the embodiments described herein are illustrative and not restrictive. From the description of the example embodiments, equivalents of the elements shown therein will suggest themselves to those skilled in the art, and ways of constructing other embodiments using the present invention will suggest themselves to practitioners of the art. Therefore, the scope of the example embodiments is not limited herein.

REFERENCE SIGNS

[0034]

100	Packable cooler bag
103	Reversible panel
106	Pocket closure
109a	First zipper
109b	Second zipper
112	Releasable attachment
115	Outer shell
118	Top closure
121	Carrying strap
124	Inner liner
127	Storage cavity

Claims

1. A packable cooler bag (100), comprising:

a cooler bag having a first sidewall and a second sidewall defining an outer shell (115) of said cooler bag, the outer shell (115) having an opening to access an interior of the cooler bag;
a pocket disposed on an exterior of said cooler bag;

said cooler bag and said pocket having a packed configuration wherein said cooler bag is inside said pocket and an unpacked configuration wherein said cooler bag is unpacked from within the pocket; and

a reversible panel (103) disposed on said outer shell (115) and defining a portion of said pocket;

wherein said cooler bag is packable from the unpacked configuration by reversibly pulling said cooler bag into the pocket so that the cooler bag is retained inside the pocket in the packed configuration.

2. The packable cooler bag (100) according to claim 1, wherein said reversible panel (103) is a portion of the pocket in said unpacked configuration.

3. The packable cooler bag (100) according to claim 2, wherein said pocket is disposed on said exterior of said cooler bag in said unpacked configuration.

4. The packable cooler bag (100) according to claim 2, wherein said reversible panel (103) is reversed in said packed configuration from said unpacked configuration and forms a portion of said pocket.

5. The packable cooler bag (100) according to claim 4, wherein said pocket contains said cooler bag in said packed configuration.

6. The packable cooler bag (100) according to claim 1, wherein said reversible panel (103) is connected to said cooler bag along three sides of said reversible panel (103).

7. The packable cooler bag (100) according to claim 6, wherein a bottom side of said three sides of said reversible panel (103) is disposed adjacent to a bottom of said outer shell (115).

8. The packable cooler bag (100) according to claim 6 further comprising a reversible zipper to open and close said pocket.

9. The packable cooler bag (100) according to claim 1 further comprising an insulating material disposed within said outer shell (115).

10. The packable cooler bag (100) according to claim 9, wherein said reversible panel (103) is uninsulated.

11. The packable cooler bag (100) according to claim 9, wherein said reversible panel (103) is insulated.

12. The packable cooler bag (100) according to claim 1, wherein said cooler bag further comprises at least one strap.

13. The packable cooler bag (100) according to claim 1, wherein said pocket is sized to contain the cooler bag when said cooler bag is compressed.

14. A method for unpacking a packable cooler bag (100), comprising the steps of:

- providing a pocket with cooler bag in a packed configuration within said pocket;
 unfastening a reversible zipper assembly of the pocket in the packed configuration;
 reversing a reversible panel (103) defining a portion of said pocket; 5
 removing said cooler bag from within said pocket; and
 obtaining a top closure (118) for the cooler bag in an unpacked configuration. 10
- 15.** The method according to claim 14 further comprising obtaining one or more carrying straps (121) of the cooler bag. 15
- 16.** The method according to claim 14 further comprising fastening the reversible zipper assembly to close the pocket.
- 17.** A method for packing a packable cooler, comprising the steps of: 20
- providing a cooler bag in an unpacked configuration with a reversible panel (103) on an outer shell (115) of said cooler bag defining a portion of a pocket; 25
 unfastening a reversible zipper of the pocket;
 grasping an internal area of the pocket and pulling the cooler bag into the internal area of the pocket as the pocket reverses from inside to outside; 30
 packing any remaining portion of the cooler bag into the pocket which is reversed.
- 18.** The method according to claim 17, further comprising the step of fastening a reversible zipper assembly when said cooler bag is in a packed configuration within said pocket. 35
- 19.** The method according to claim 17, further comprising compressing the cooler bag while said pulling the cooler bag into the internal area of said pocket occurs. 40

45

50

55

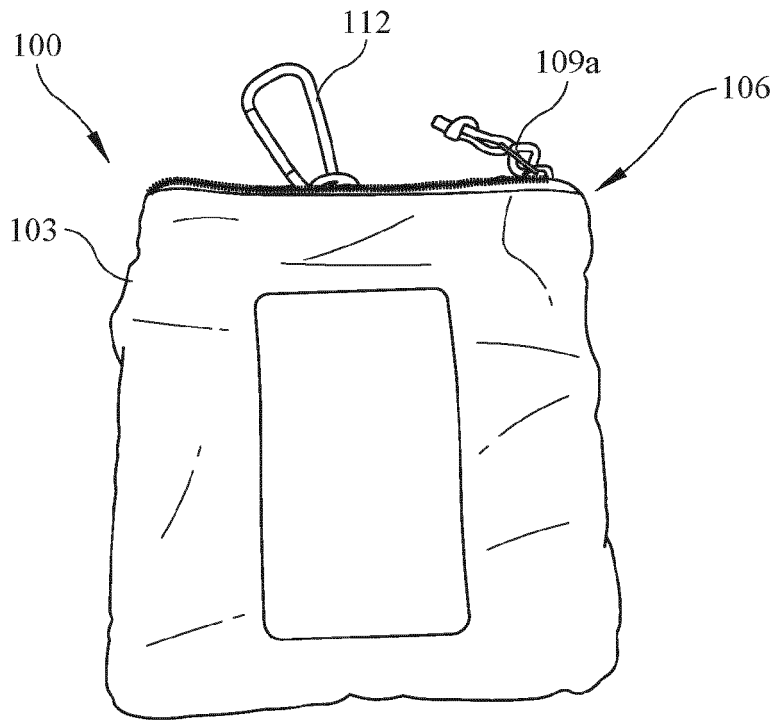

FIG. 1A

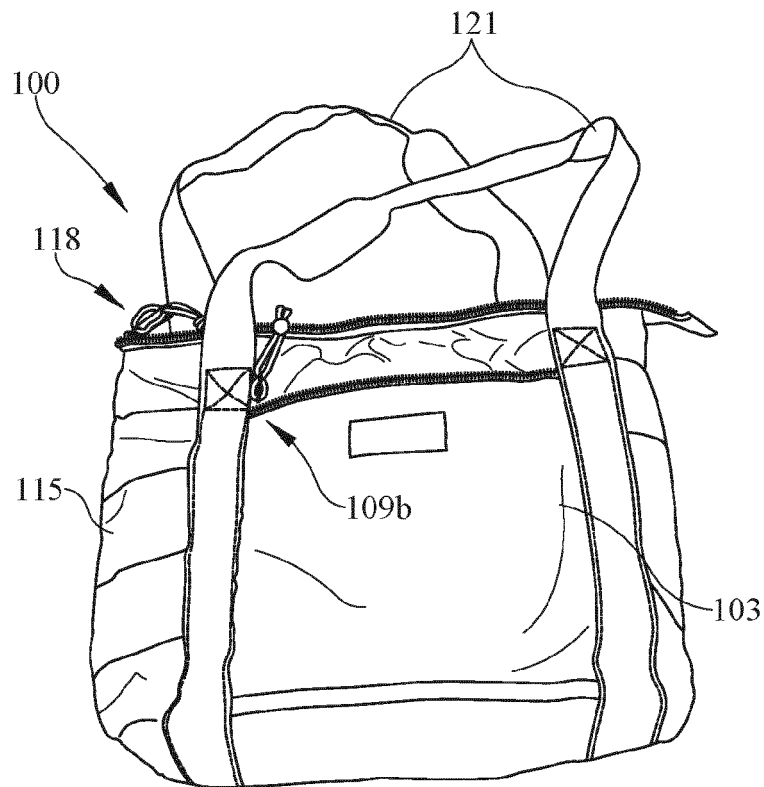

FIG. 1B

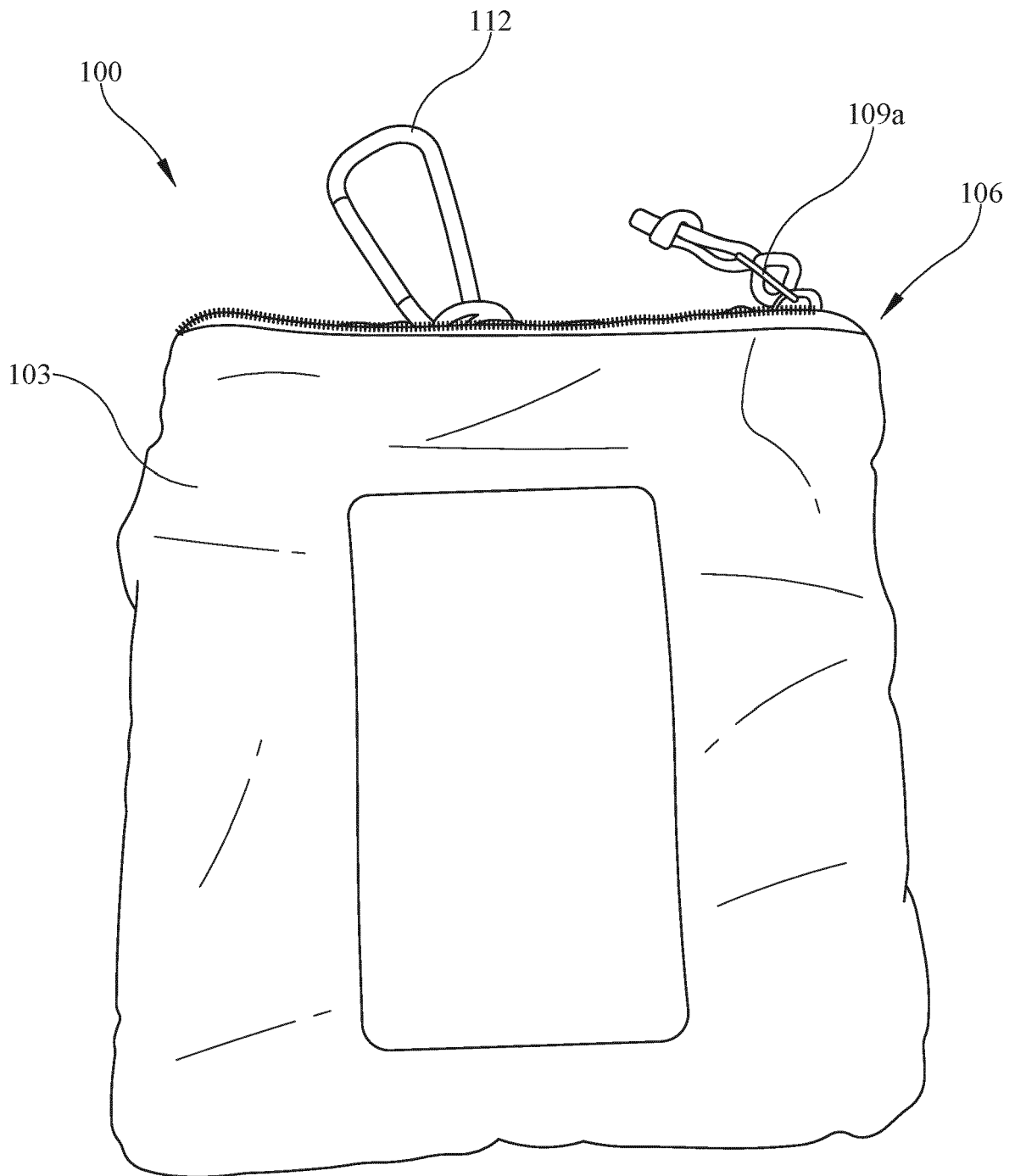

FIG. 2A

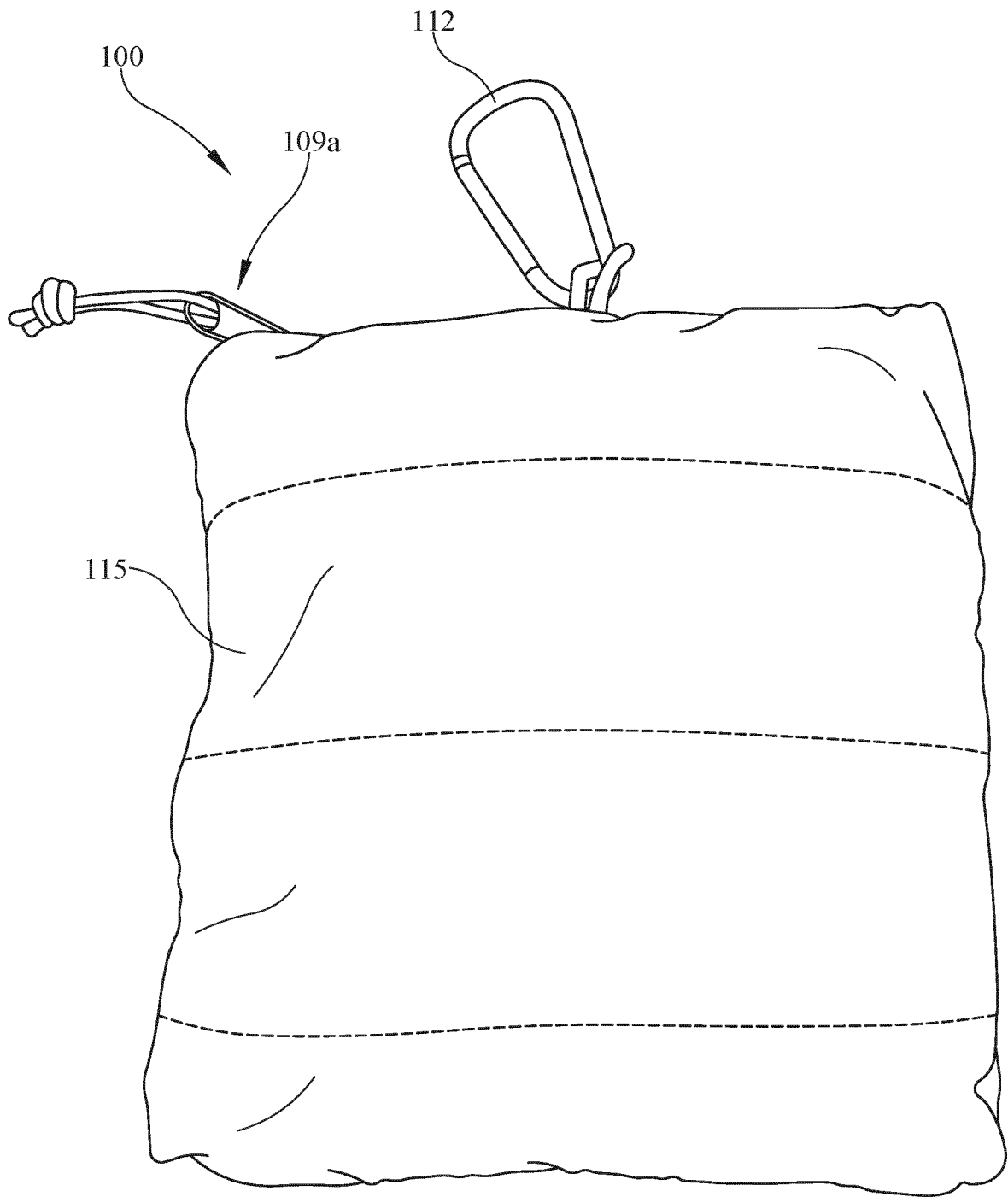

FIG. 2B

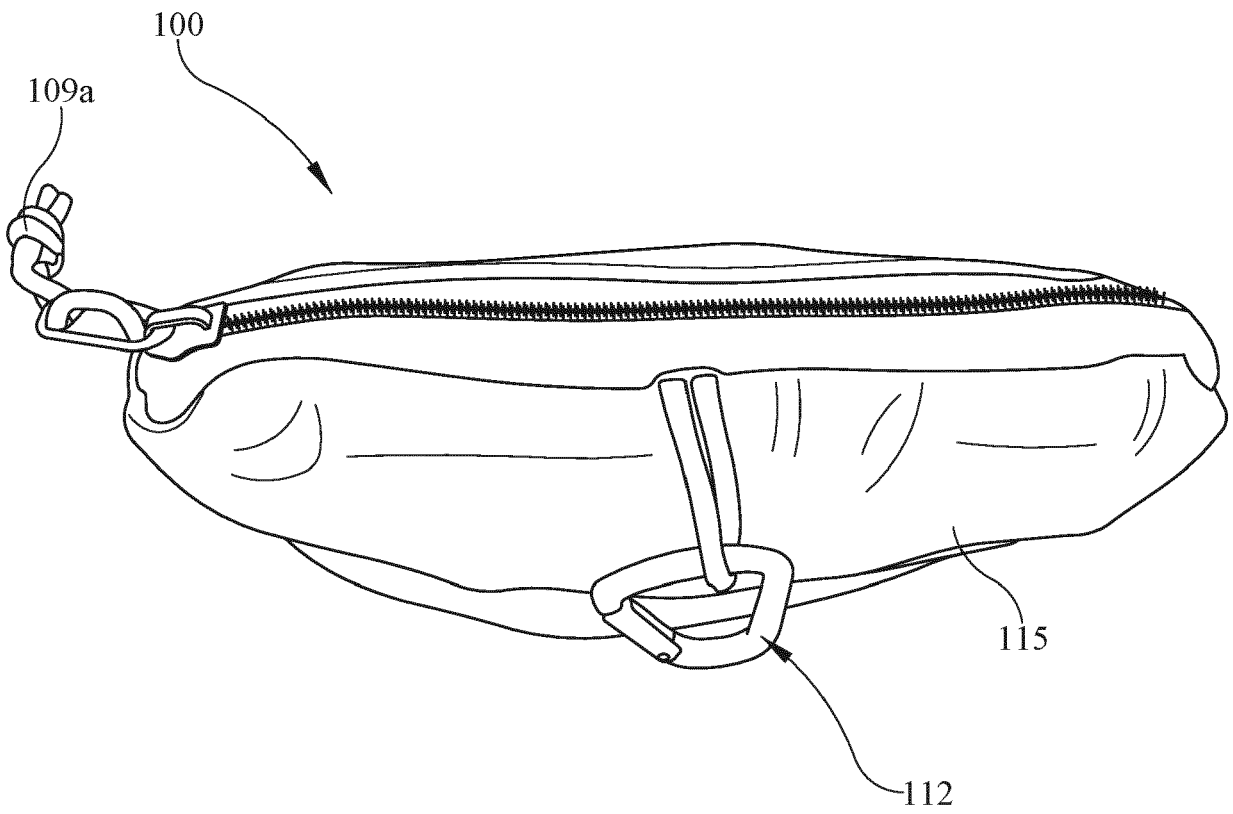

FIG. 2C

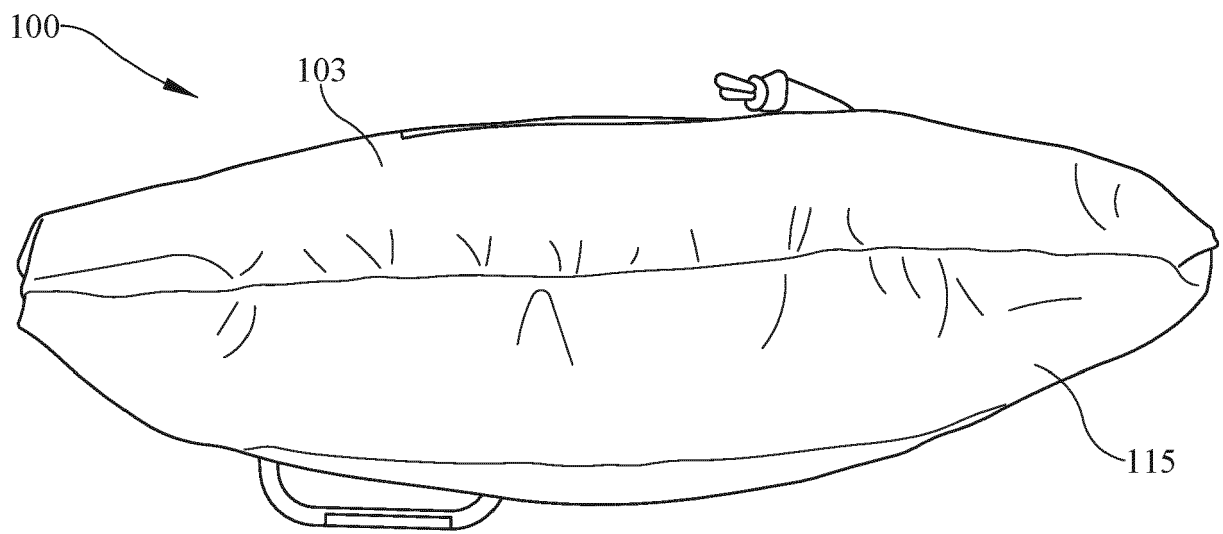

FIG. 2D

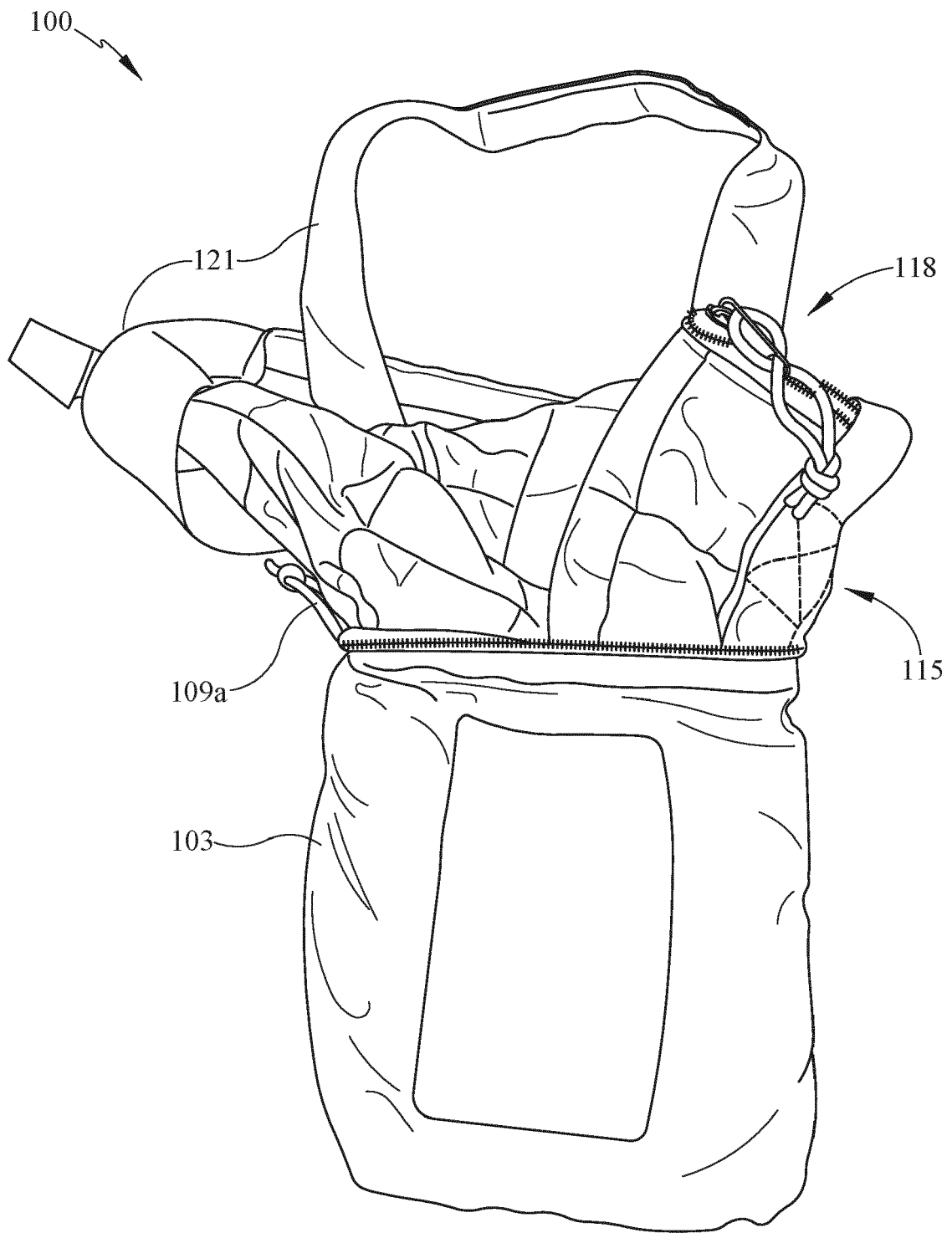

FIG. 3A

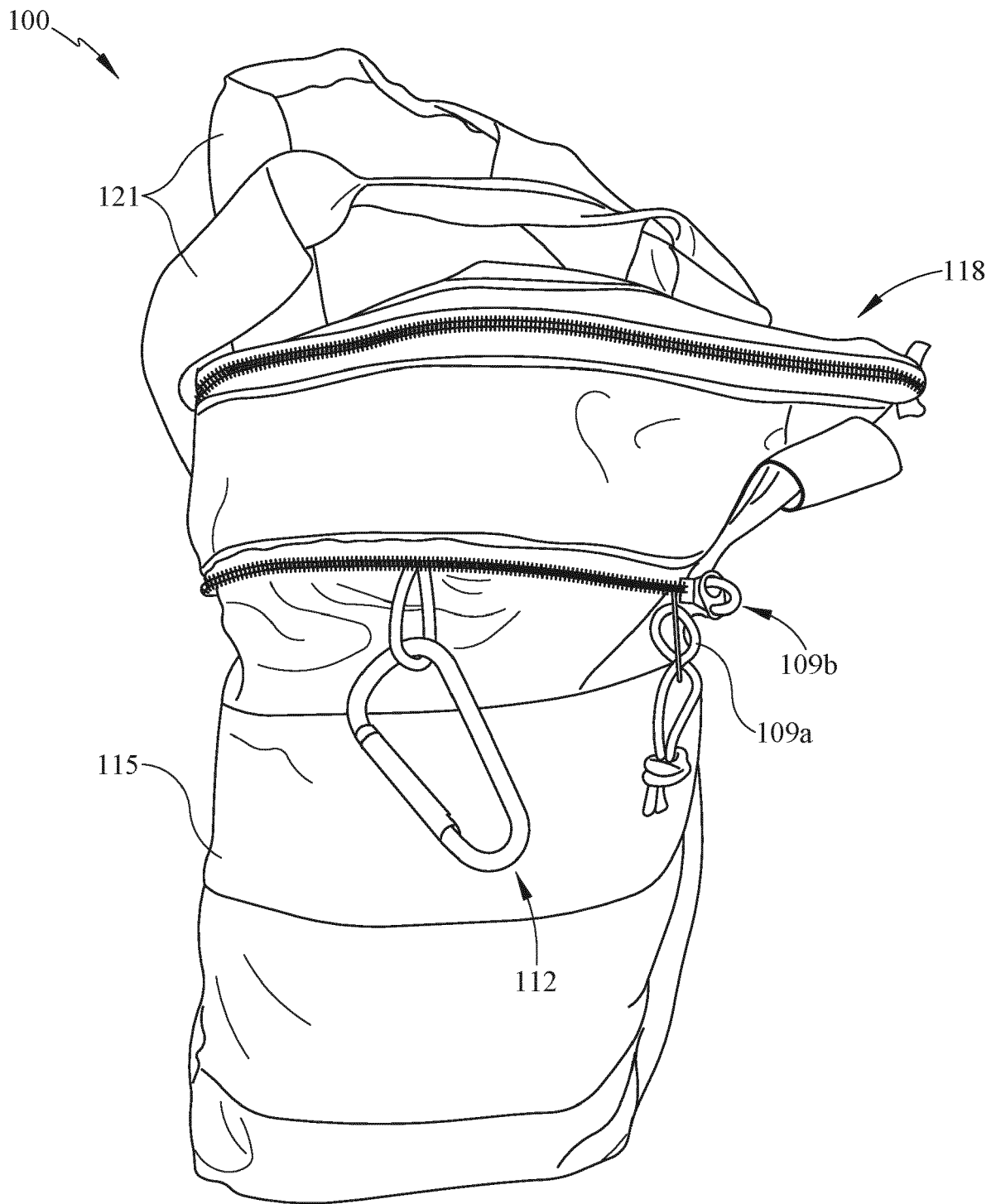

FIG. 3B

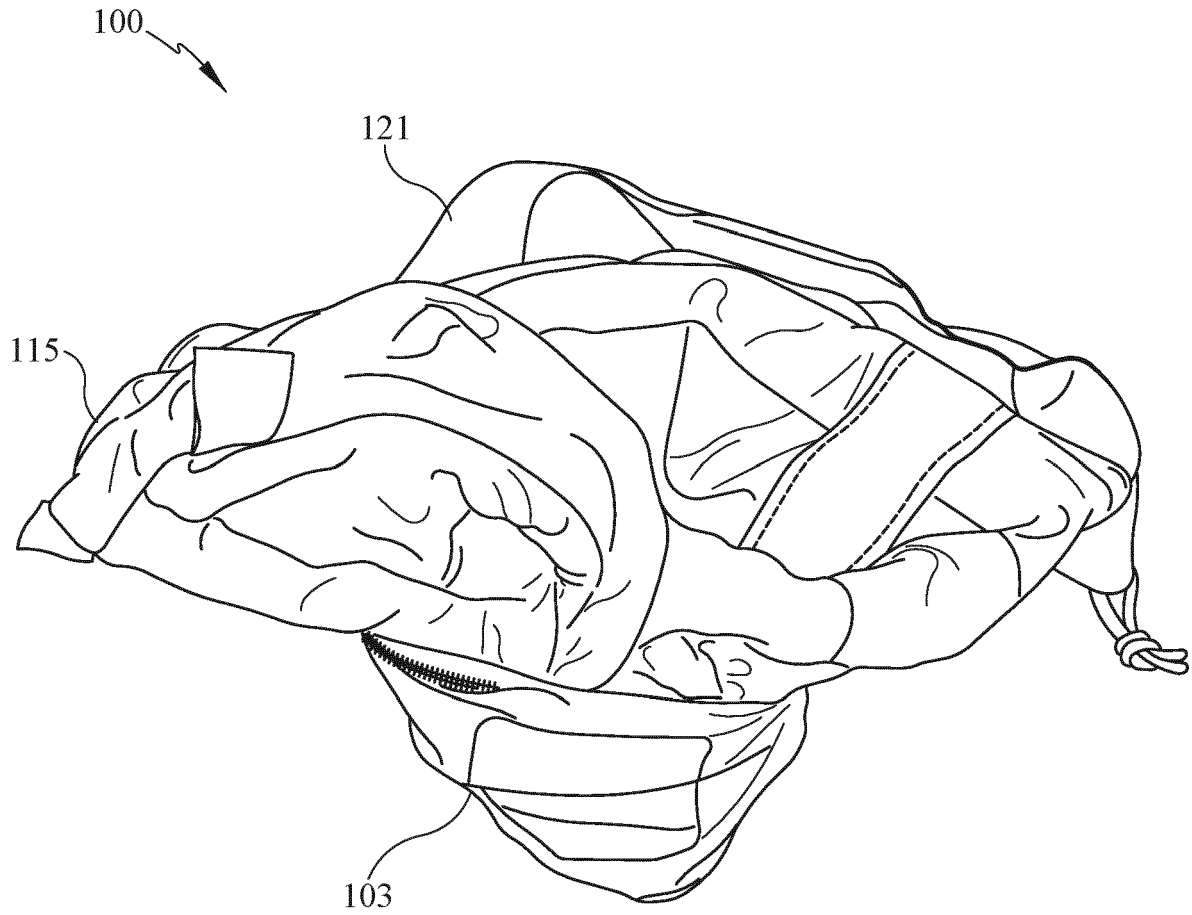

FIG. 3C

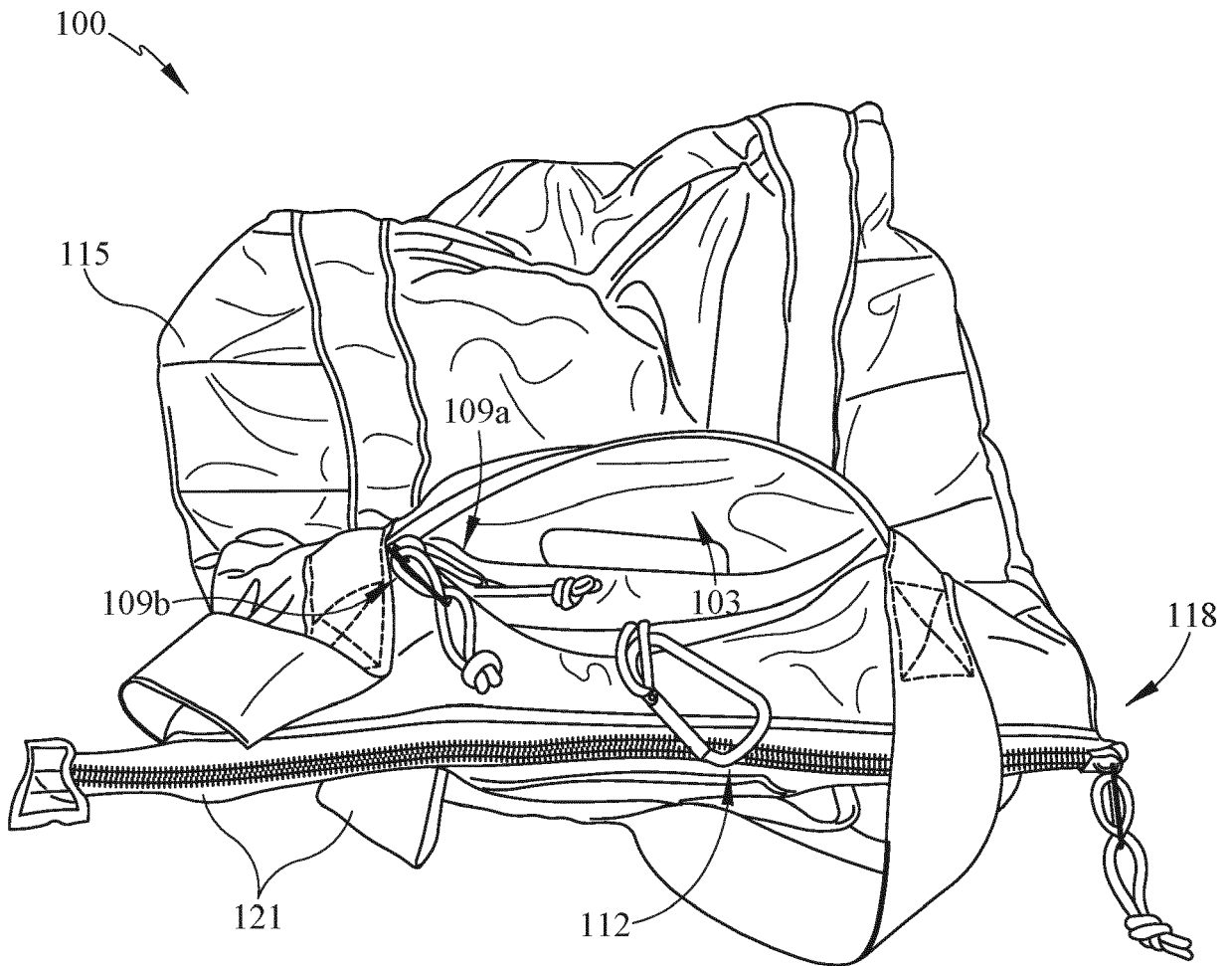

FIG. 3D

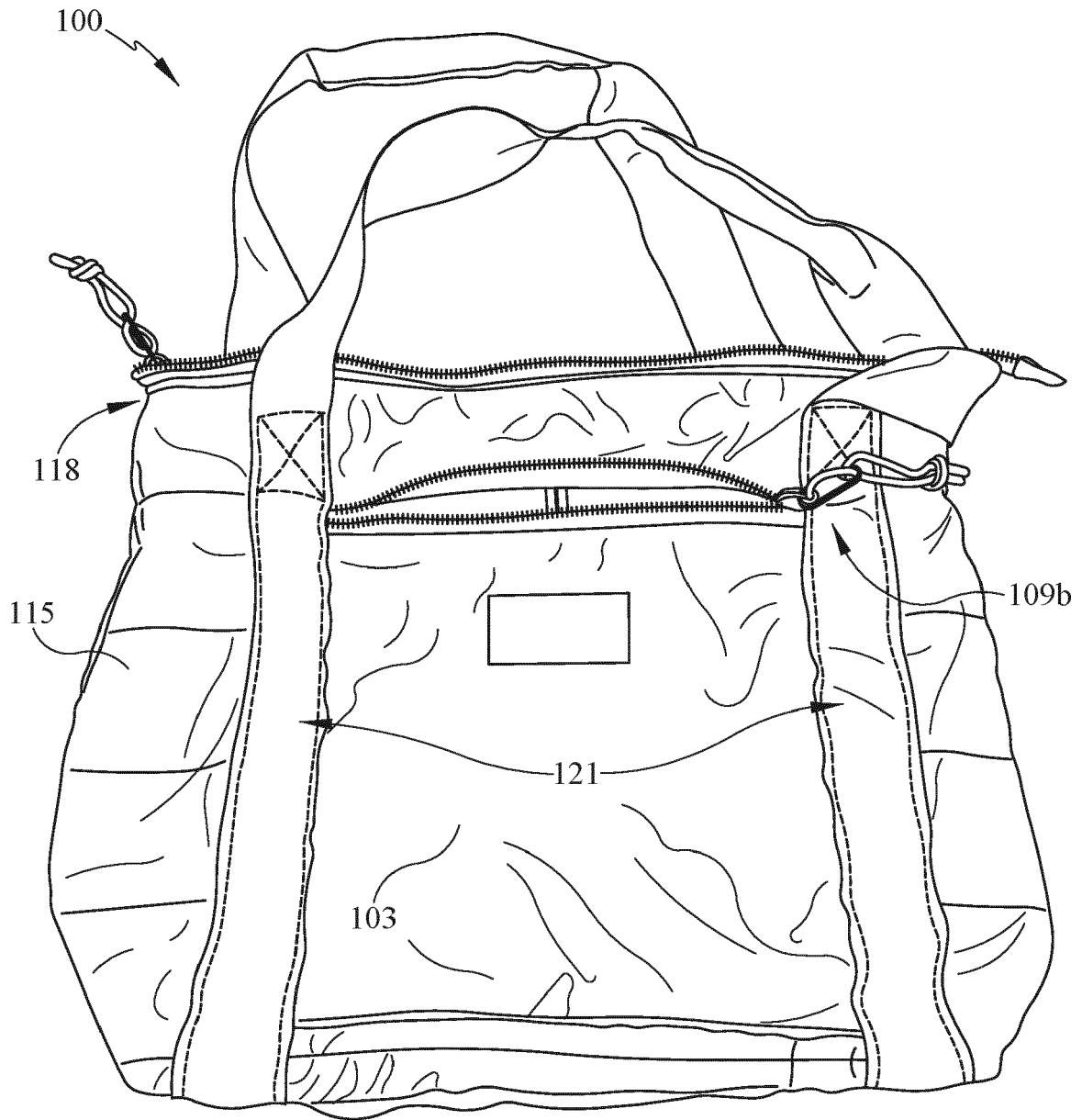

FIG. 3E

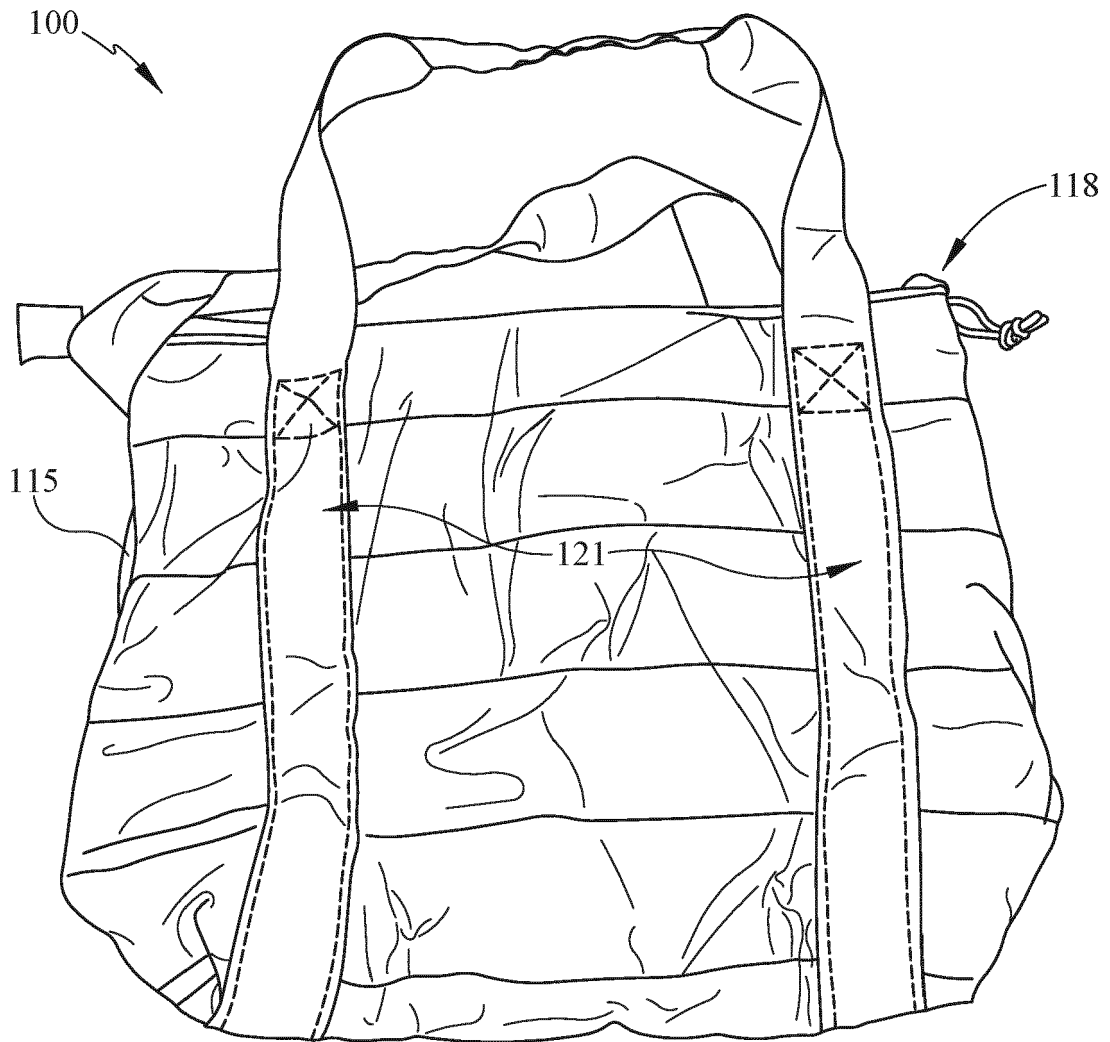

FIG. 3F

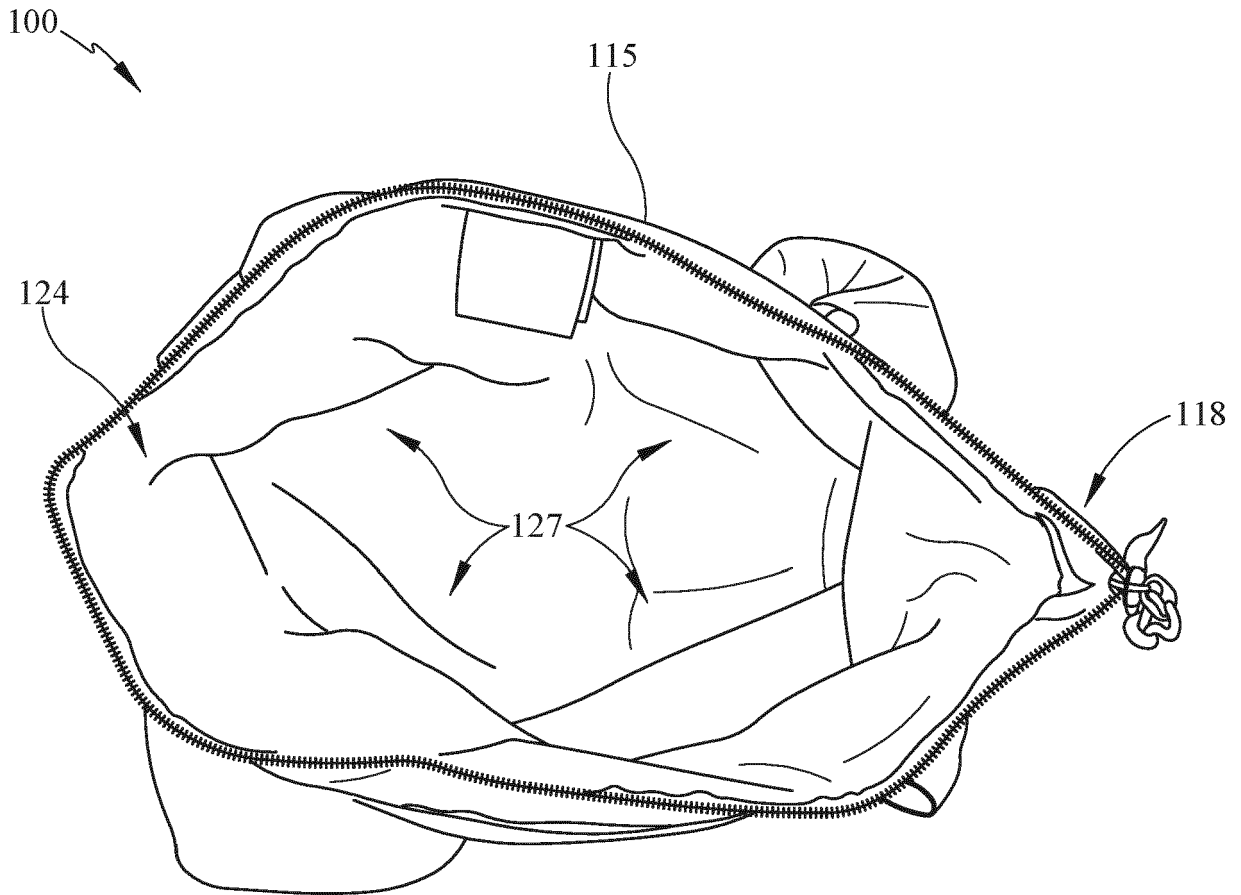

FIG. 3G

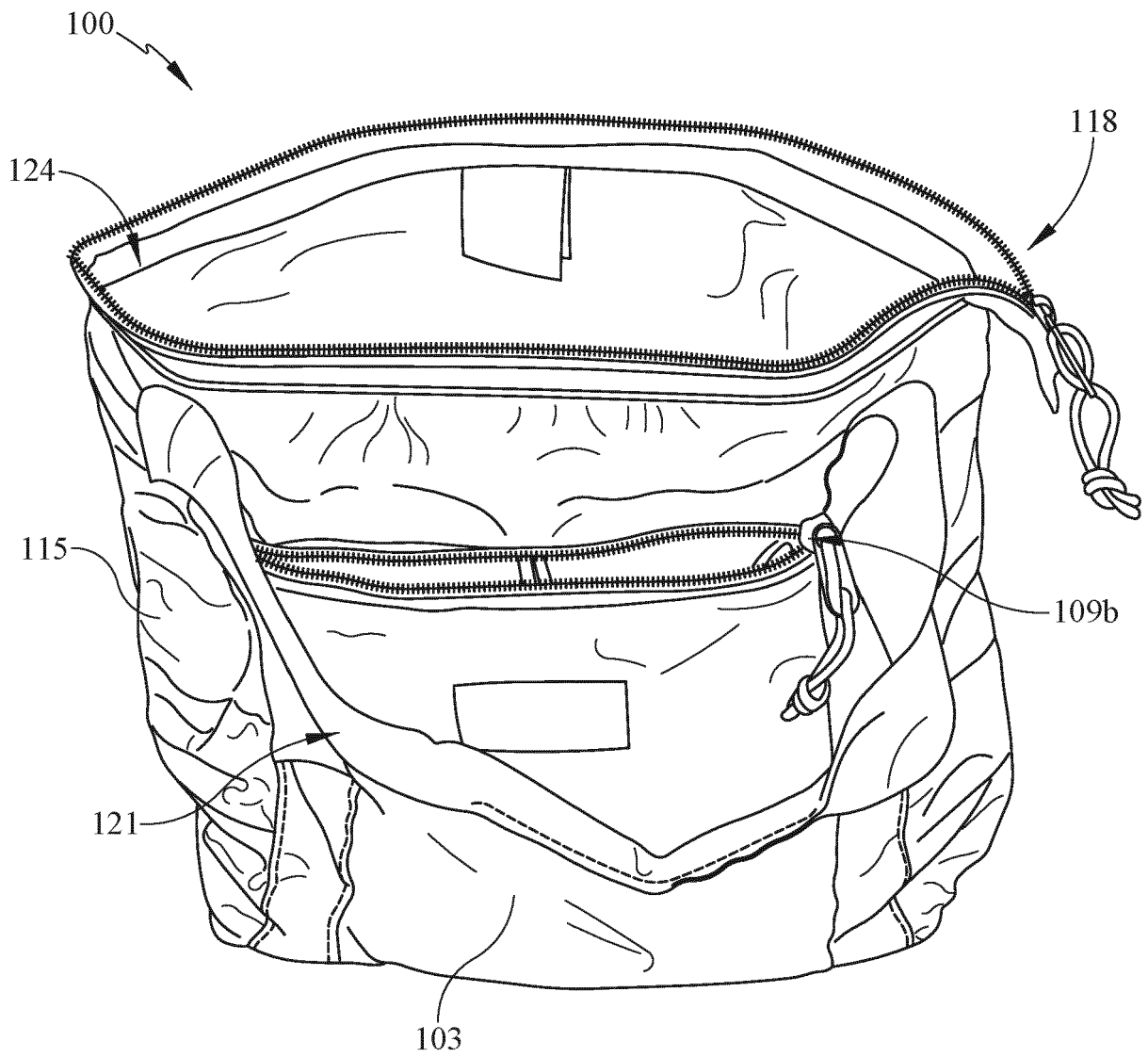

FIG. 3H

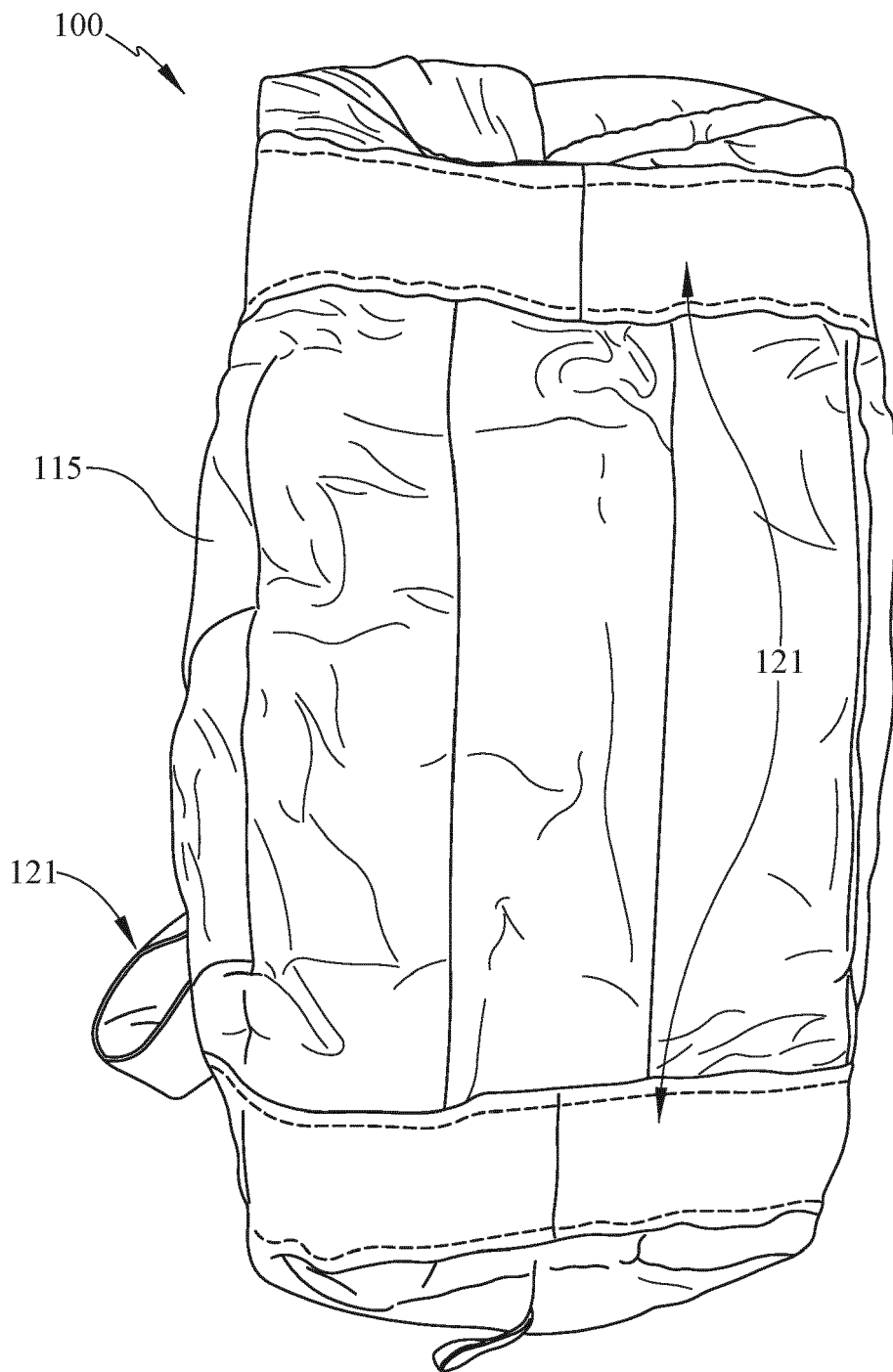

FIG. 3I

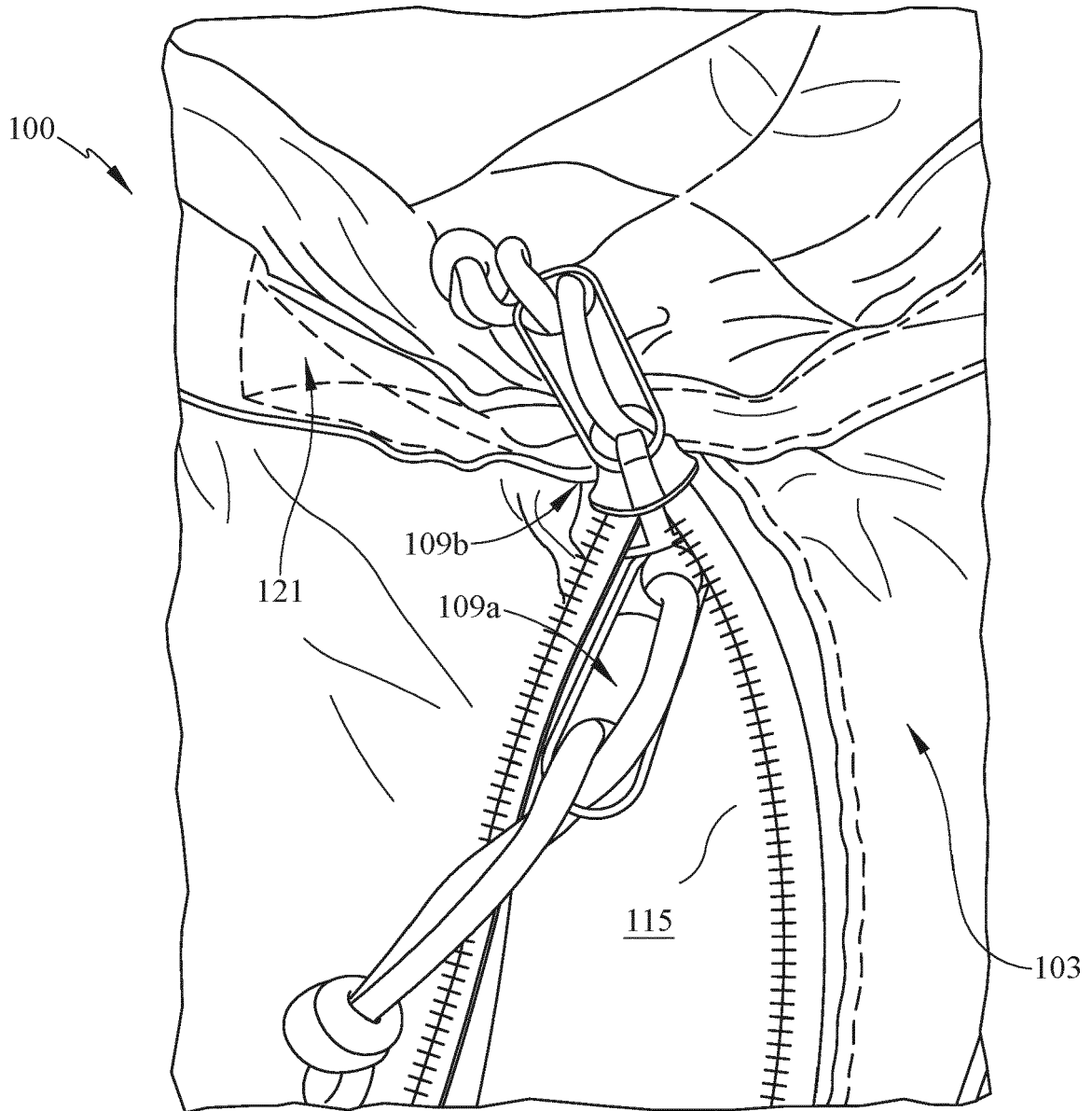

FIG. 3J

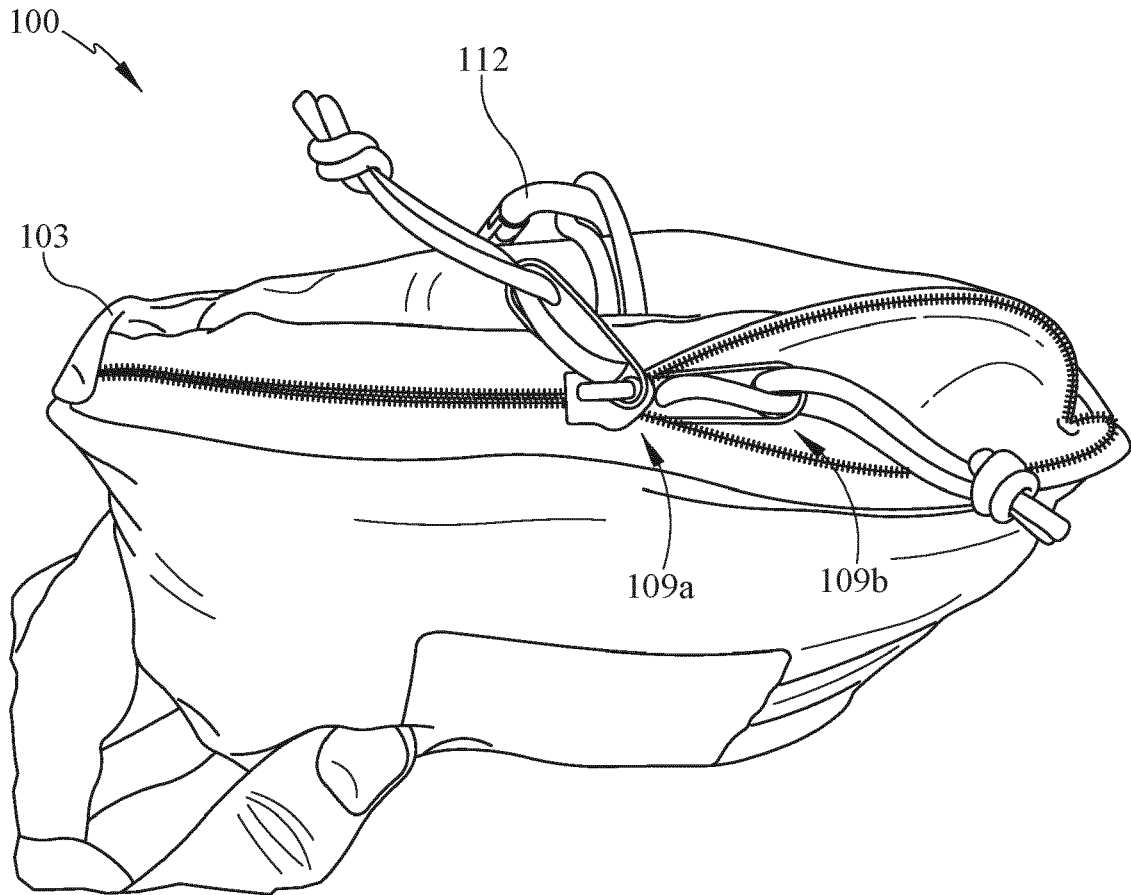

FIG. 3K



EUROPEAN SEARCH REPORT

Application Number

EP 22 16 8009

5

10

15

20

25

30

35

40

45

50

55

DOCUMENTS CONSIDERED TO BE RELEVANT			
Category	Citation of document with indication, where appropriate, of relevant passages	Relevant to claim	CLASSIFICATION OF THE APPLICATION (IPC)
X	US 2006/228051 A1 (YU CHRIS [US]) 12 October 2006 (2006-10-12)	1-8, 12-19	INV. A45C7/00
Y	* paragraphs [0031] - [0043]; figures 6-8 *	9-11	A45C11/20
Y	----- US 2011/182532 A1 (BALTUS LINDA [US]) 28 July 2011 (2011-07-28) * paragraphs [0003] - [0032]; figures * -----	9-11	
			TECHNICAL FIELDS SEARCHED (IPC)
			A45C A45F
The present search report has been drawn up for all claims			
Place of search The Hague		Date of completion of the search 20 September 2022	Examiner Dinescu, Daniela
CATEGORY OF CITED DOCUMENTS X : particularly relevant if taken alone Y : particularly relevant if combined with another document of the same category A : technological background O : non-written disclosure P : intermediate document		T : theory or principle underlying the invention E : earlier patent document, but published on, or after the filing date D : document cited in the application L : document cited for other reasons & : member of the same patent family, corresponding document	

1
EPO FORM 1503 03:82 (P04C01)

**ANNEX TO THE EUROPEAN SEARCH REPORT
ON EUROPEAN PATENT APPLICATION NO.**

EP 22 16 8009

5 This annex lists the patent family members relating to the patent documents cited in the above-mentioned European search report.
The members are as contained in the European Patent Office EDP file on
The European Patent Office is in no way liable for these particulars which are merely given for the purpose of information.

20-09-2022

10	Patent document cited in search report	Publication date	Patent family member(s)	Publication date
	US 2006228051 A1	12-10-2006	NONE	

15	US 2011182532 A1	28-07-2011	US 2011182532 A1 WO 2011094355 A1	28-07-2011 04-08-2011

20				
25				
30				
35				
40				
45				
50				
55				

EPO FORM P0459

For more details about this annex : see Official Journal of the European Patent Office, No. 12/82