

O. L. WILLIAMS.  
GATE.

APPLICATION FILED SEPT. 26, 1904.

2 SHEETS—SHEET 1.

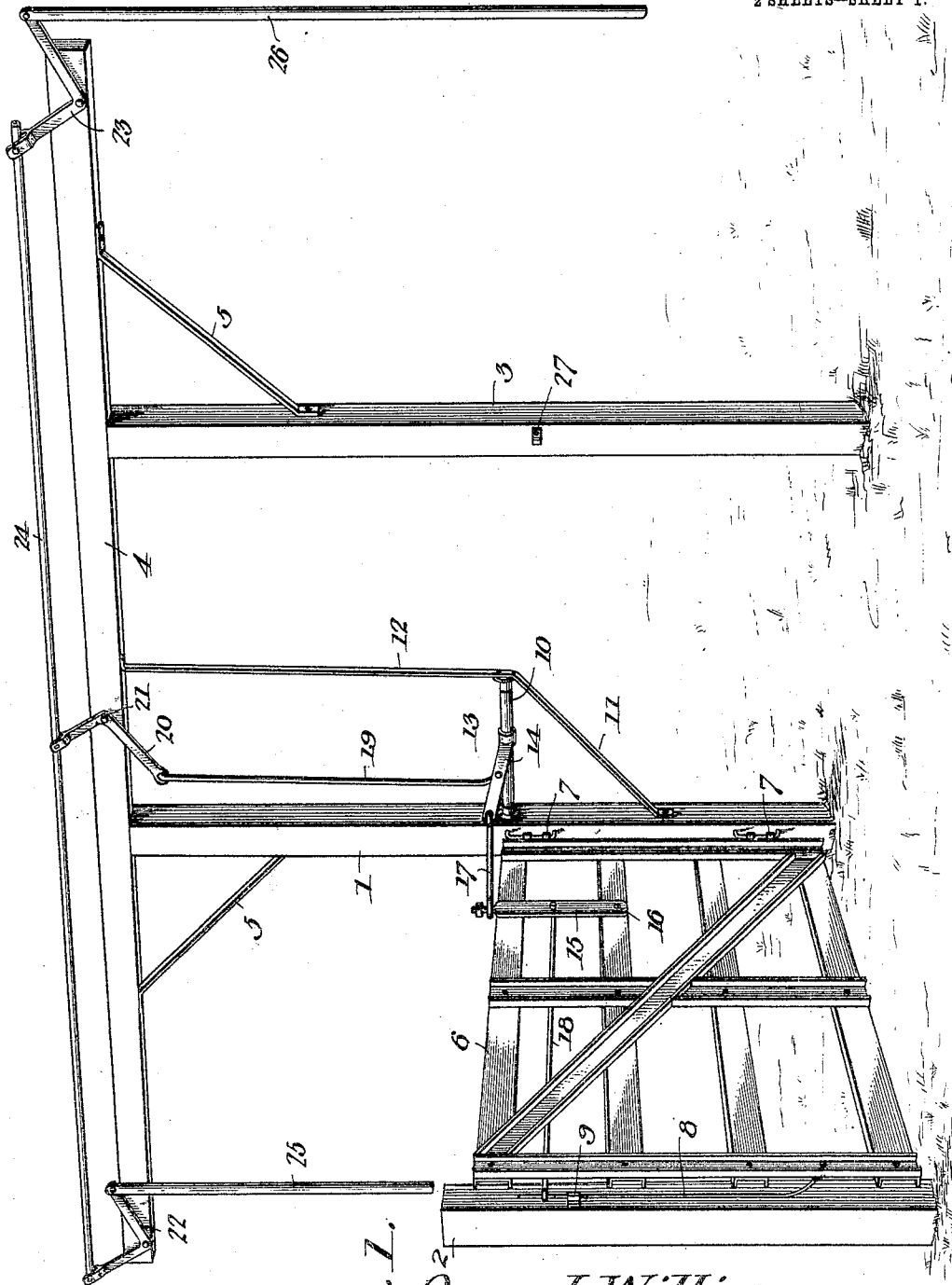

Witnesses  
*E. J. Stewart*  
*H. J. Shepard*

*Fig. 1.*

*Oscar L. Williams*, Inventor,  
 by *C. Knowles*,  
 Attorneys

O. L. WILLIAMS.  
GATE.

APPLICATION FILED SEPT. 26, 1904.

2 SHEETS—SHEET 2.

Fig. 3.

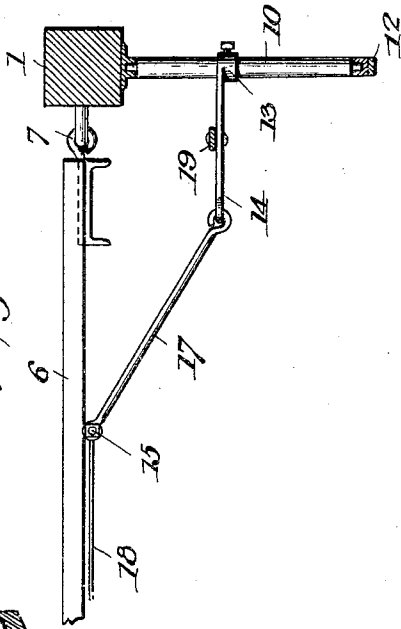

Fig. 4.

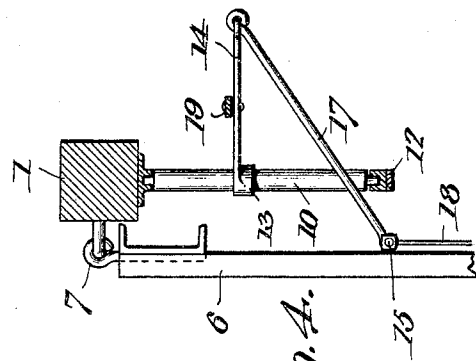
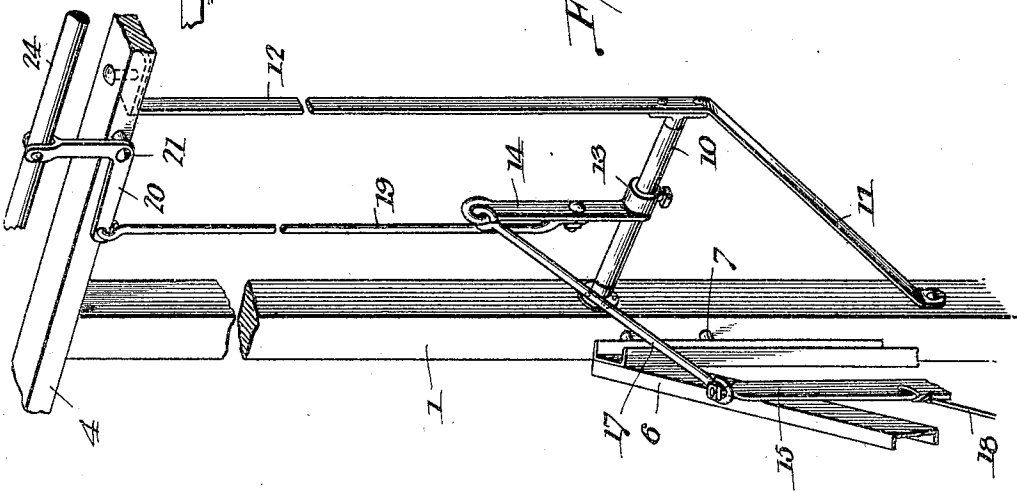

Fig. 2.



Witnesses  
*E. H. Shepard*  
*H. A. Shepard*

*Oscar L. Williams,*  
 Inventor.  
 by *C. Snow & Co.,*  
 Attorneys

# UNITED STATES PATENT OFFICE.

OSCAR LLOYD WILLIAMS, OF MONTICELLO, ILLINOIS.

## GATE.

SPECIFICATION forming part of Letters Patent No. 791,064, dated May 30, 1905.

Application filed September 26, 1904. Serial No. 226,041.

*To all whom it may concern:*

Be it known that I, OSCAR LLOYD WILLIAMS, a citizen of the United States, residing at Monticello, in the county of Piatt and State of Illinois, have invented a new and useful Gate, of which the following is a specification.

This invention relates to gates, and has for its object to provide for simultaneously releasing the gate-latch and swinging the gate open and closed and to effect the opening and closing of the gate in a simple and expeditious manner. It is furthermore designed to arrange the gate for use across roadways and to provide for the actuation of the controlling means without requiring that the traveler dismount.

A still further object of the invention is to arrange the controlling means for application to any ordinary form of swinging gate and to provide for the erection of the apparatus without altering the mounting of the gate.

With these and other objects in view the present invention consists in the combination and arrangement of parts, as will be hereinafter more fully described, shown in the accompanying drawings, and particularly pointed out in the appended claims, it being understood that changes in the form, proportion, size, and minor details may be made within the scope of the claims without departing from the spirit or sacrificing any of the advantages of the invention.

In the accompanying drawings, Figure 1 is a perspective view of a gate embodying the features of the present invention and shown in its closed position. Fig. 2 is a detail perspective view showing the positions assumed by the parts of the gate-actuating mechanism in the intermediate position of the gate. Fig. 3 is a detail plan view showing the relation of parts in the closed position of the gate. Fig. 4 is a similar view showing the relation of parts in the open position of the gate.

Like characters of reference designate corresponding parts in each and every figure of the drawings.

In setting up a gate in accordance with the present invention a hinge-post 1 and a latch-post 2 are erected at opposite sides of a roadway, with the post 1 rising to a suitable dis-

tance above the post 2. Another latch-post, 3, is erected upon the same side of the roadway as the post 1 and equal in height thereto. A beam or bar 4 is supported upon the tops of the posts 1 and 2 and is projected a suitable distance beyond the same, there being braces 5 extending between the beam and the respective posts.

A swinging gate 6 of any suitable form, preferably formed of steel bars, is supported upon the post 1 by means of suitable hinges 7, which permit of a vertical movement of the gate sufficient to clear accumulations of snow and ice. Upon the outer or free end bar of the gate is a spring-latch 8, consisting of an upstanding spring rod or bar secured at its lower end to the gate, with its upper end free therefrom and its intermediate portion arranged to engage a suitable keeper 9 upon the latch-post 2.

The means for operating the gate includes a rotatable substantially horizontal bar 10, carried by and projected from the post 1 at substantially right angles to the gate in its closed position, said bar being provided with braces 11 and 12, extending between its outer end and the post 1 and the beam 4. Upon this bar is a tubular slide 13, which is also capable of rotation with the bar and carries a crank-arm 14. An upstanding lever 15 is fulcrumed at its lower end, as at 16, upon the gate, adjacent the hinged end thereof, and a link 17 extends between the upper end of the lever and the outer end of the crank-arm 14, there being a connecting-rod 18 extending between the lever 15 and the spring-latch 8 of the gate. An upright connecting-rod 19 rises from an intermediate portion of the crank-arm 14 and has its upper end connected to one arm of a bell-crank lever 20, which is fulcrumed, as at 21, upon the beam 4. At opposite ends of the beam 4 similar bell-crank levers 22 and 23 are fulcrumed, and the corresponding arms thereof are connected by a rod or bar 24, so as to operate simultaneously. Handles 25 and 26 depend from the corresponding other arms of the bell-crank levers 22 and 23 for use in controlling the apparatus from opposite sides of the gate.

When the gate is in closed position, the le-

ver 15 and the connecting-rod 19 stand in upright positions, and when either of the handles 25 and 26 is pulled downwardly, so as to swing upwardly the bell-crank lever 20, the connecting-rod 19 will be raised and the crank-arm 14 swung upwardly upon the bar 10 as a support which rotates in its bearings, thereby drawing the link 17 rearwardly and tilting the lever 15, which draws upon the rod 18 and releases the latch 8 from the keeper 9. Continued movement of the operating-handle tends to swing the gate open toward the other latch-post 3 until the crank-arm 14 passes the perpendicular, whereupon the handle is pushed upwardly, so as to continue the swinging movement of the crank-arm 14 downwardly upon the opposite side of the bar or bracket 10, which results in a continuance of the swinging movement of the gate to its open position, with the latch 8 snapped into engagement with a keeper 27 upon the latch-post 3. During the swinging movement of the gate the rod 17 of course swings upon the crank-arm 14 under the influence of the gate, so as to prevent binding of the rod upon the crank-arm 14. With the gate in its open position manipulation of either of the handles 25 and 26 will first release the latch and then swing the gate into its closed position by a reverse movement of the crank-arm 14.

From the foregoing description it will be understood that the present gate-operating means is capable of application to any ordinary swinging gate without altering the construction and mounting thereof, and the frame structure for the support of the apparatus may be conveniently erected. Furthermore, the several parts of the apparatus may be readily assembled and mounted in operative position without requiring any particular degree of skill or experience.

A very important advantage of the present

apparatus resides in the omission of cables and similar loose connections, whereby any movement on the part of either of the handles imparts a positive movement to all of the parts of the apparatus, whereby accumulations of ice, rust, &c., may be effectually broken up and a prompt and effective operation of the gate insured.

Having fully described the invention, what is claimed is—

1. The combination with a gate-post and a swinging gate carried thereby, of a beam supported by the gate-post and projected at opposite sides of the gate, a rotatable bar carried by the post and projected at substantially right angles to the gate in its closed position, a crank-arm carried by the bar, a connection between the crank-arm and the gate, end and intermediate bell-crank levers fulcrumed upon the beam, handles pendent from the terminal bell-cranks, a cross-bar connecting the bell-cranks, and a connecting-rod extending between the crank-arm and the intermediate bell-crank.

2. The combination with a swinging gate having a latch and a latch-post having a keeper for engagement by the latch, of a lever fulcrumed upon the gate and connected to the latch, a substantially horizontal bar supported independently of the gate, a crank-arm carried by the bar, a link extending between the crank-arm and the lever, and controlling means connected to the crank-arm for swinging the same around the bar as a support.

In testimony that I claim the foregoing as my own I have hereto affixed my signature in the presence of two witnesses.

OSCAR LLOYD WILLIAMS.

Witnesses:

JESSE B. IRWIN,  
BENJAMIN F. KAGEY.