



INTERNATIONAL APPLICATION PUBLISHED UNDER THE PATENT COOPERATION TREATY (PCT)

| | | |
|--|------------------|--|
| <p>(51) International Patent Classification ⁵ : G11B 23/44</p> | <p>A1</p> | <p>(11) International Publication Number: WO 90/04253 (43) International Publication Date: 19 April 1990 (19.04.90)</p> |
|--|------------------|--|

| | |
|---|---|
| <p>(21) International Application Number: PCT/US89/04362 (22) International Filing Date: 4 October 1989 (04.10.89) (30) Priority data: 254,987 7 October 1988 (07.10.88) US (71) Applicant: EASTMAN KODAK COMPANY [US/US]; 343 State Street, Rochester, NY 14650 (US). (72) Inventors: WASH, Michael, Lee ; 38 Bending Oak Drive, Pittsford, NY 14534 (US). WHITFIELD, Arthur, Allan ; 251 Drumcliff Way, Rochester, NY 14612 (US). (74) Agent: KAUFMAN, Stephen, C.; 343 State Street, Rochester, NY 14650 (US).</p> | <p>(81) Designated States: AT (European patent), AU, BE (European patent), BR, CH (European patent), DE (European patent), FR (European patent), GB (European patent), IT (European patent), JP, KR, LU (European patent), NL (European patent), SE (European patent), SU. Published <i>With international search report.</i></p> |
|---|---|

(54) Title: SELF-CLOCKING ENCODING/DECODING FILM INFORMATION EXCHANGE SYSTEM USING DEDICATED MAGNETIC TRACKS ON FILM

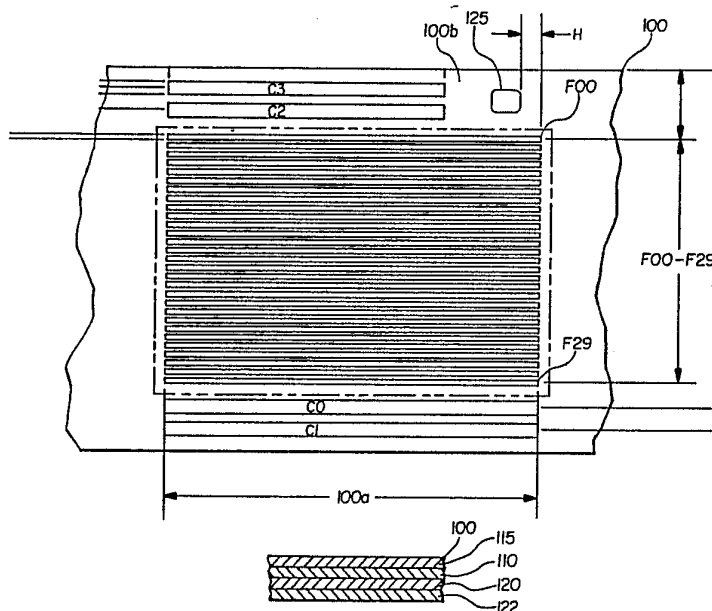

(57) Abstract

A virtually transparent magnetic layer is included as an additional layer in a color negative film. Information exchange between various users of the film -such as (for example) the film manufacturer, the camera user, the dealer and photofinisher- is carried via plural longitudinal magnetic tracks on the film that begin and end in individual frames. Each track is dedicated to the writing and reading of a predetermined set of parameters related to the corresponding frame. The photofinisher-dedicated tracks fill the exposed image area of each frame. The camera-dedicated tracks lie along the edges of the film between the film perforations, the perforations being widely spaced for the purpose. All data is recorded on the film using a novel self-clocking code which is completely self-clocking, in order to provide automatic data synchronization between the various users without requiring that any of them to transport the film at the same speed or even at a uniform speed when reading and writing.

FOR THE PURPOSES OF INFORMATION ONLY

Codes used to identify States party to the PCT on the front pages of pamphlets publishing international applications under the PCT.

| | | | | | |
|----|------------------------------|----|--|----|--------------------------|
| AT | Austria | ES | Spain | MG | Madagascar |
| AU | Australia | FI | Finland | ML | Mali |
| BB | Barbados | FR | France | MR | Mauritania |
| BE | Belgium | GA | Gabon | MW | Malawi |
| BF | Burkina Fasso | GB | United Kingdom | NL | Netherlands |
| BG | Bulgaria | HU | Hungary | NO | Norway |
| BJ | Benin | IT | Italy | RO | Romania |
| BR | Brazil | JP | Japan | SD | Sudan |
| CA | Canada | KP | Democratic People's Republic of Korea | SE | Sweden |
| CF | Central African Republic | KR | Republic of Korea | SN | Senegal |
| CG | Congo | LI | Liechtenstein | SU | Soviet Union |
| CH | Switzerland | LK | Sri Lanka | TD | Chad |
| CM | Cameroon | LU | Luxembourg | TG | Togo |
| DE | Germany, Federal Republic of | MC | Monaco | US | United States of America |
| DK | Denmark | | | | |

-1-

SELF-CLOCKING ENCODING/DECODING
FILM INFORMATION EXCHANGE SYSTEM
USING DEDICATED MAGNETIC TRACKS ON FILM

5

BACKGROUND OF THE INVENTION

Limitations of Current Consumer Photography
Technology

Communication between the camera user and
10 the dealer or photofinisher typically requires
written forms which are filled out by the user,
usually well after a given scene has been
photographed. Thus, in addition to the
inconvenience of filling out such a form,
15 scene-related information is typically lost or
forgotten. Such information may include the user's
desire to not have a particular frame printed or to
have several prints made from a given frame, for
example. Such information may also include the
20 photographic parameters of the scene, observed by
the user or by a sensor, which would have aided the
photofinisher's classification of the scene to
increase the quality of the prints made from the
film.

25 Several factors reduce the efficiency of
the overall photofinishing process. For example, in
a large photofinishing laboratory not operating on a
24 hour per day basis, the film processing equipment
must lie dormant for a period of time at the
30 beginning of each work day until enough incoming
customer film has been sorted to form one batch of a
minimum number (e.g. 70) of film strips of the same
type (such as color negative 35 mm film) to justify
running the printing equipment. Of course,
35 undeveloped film (regular customer orders) must be

-2-

separated from developed film (print re-orders).

More significant sources of inefficiency in the photofinishing process include the mechanical steps required to maintain proper correspondence
5 between each film strip and the prints made from it, as well as the customer's identity. These mechanical steps include the sorting and handling of each form or envelope originally filled out by the customer so that the envelope follows the customer's
10 film strip throughout the photofinishing process and winds up with the corresponding set of prints.

One of the most significant sources of inefficiency in the photofinishing process arises from the necessity of re-printing an image from a
15 particular frame on a customer's film strip whenever inspection reveals that the corresponding original print was incorrectly made (usually by an incorrect exposure of the photosensitive print paper to the developed film negative image). In order to replace
20 the original print with a better (so-called "makeover") print, the exposure conditions ("classification") used to make the original print from the negative film image must first be corrected. Somehow, the particular film negative
25 frame in question must be re-classified and then re-printed while preserving the original prints of the other frames. The mechanical steps include notching the prints to indicate the boundaries between adjacent prints and between adjacent orders
30 on a roll of prints as well as marking any original print requiring a makeover in a labor intensive procedure which ensures that proper correspondence between each film strip and the corresponding original prints, makeover prints and customer order
35 form (envelope) is never lost.

-3-

Problems to be Solved by the Invention

Recording of information on the film has been loosely suggested as one possible way around some of the limitations described above. These
5 suggestions have ranged from optical recording of eye-readable symbols or machine readable symbols to the magnetic recording of machine readable data. Of course, optical recording on the film has only limited use, because once the film has been
10 developed, no further recording may be done. Furthermore, the information must be restricted to those limited areas on the film not occupied by the camera-exposed image of each frame, a significant limitation on the amount of information that can be
15 recorded.

With magnetic recording in a virtually transparent magnetic layer, high density recording may be done everywhere on the film including in the image area, so that all relevant information
20 theoretically could be recorded with each frame on the film. However, what has not been recognized in the prior art is that complete exploitation of the potential capabilities of magnetic recording on film results in an unwieldy mass of data being recorded
25 on the film, various bits of which must be separately accessed at various stages of the film use by camera and photofinisher. In such a scenario, the photofinisher in particular must find a certain needle of data in a massive haystack of
30 data at a given step in the photofinishing process.

A problem underlying all of the foregoing is that neither the camera nor any particular stage of the photofinisher may be relied upon to transport the film at some pre-defined velocity while data is
35 being recorded or read, nor even at a uniform

-4-

velocity. Thus, an awkward requirement could arise that clocking or velocity information be recorded in a separate track each time data is recorded in one of the dedicated tracks. Such a requirement would
5 complicate the recording process, making it less reliable, and reduce the area on the film available for recording information.

Another problem is how to provide the photofinisher with an automatic indication whenever
10 a particular film strip has been spliced in a roll of film strips but rotated (either end-for-end or emulsion side up) with respect to its original orientation (as established during data recording in the camera or at an order entry station).

15 Another problem arises if the accommodation of magnetic reading/writing on the film by both the camera and the various dealer and photofinishing stages precludes the photofinisher from reading/writing on film formats (e.g. 110 or 126 film)
20 adapted to ordinary cameras not having magnetic read/write capability. The problem here is how to permit the photofinisher to use magnetic recording on film without regard to the format of the film or the type of camera used, using the same magnetic
25 recording format and hardware for all cases. Solving this last problem would permit all film for all cameras to include the additional magnetic layer, for photofinishing with the same magnetic read/write format and automated protocols using the
30 film magnetic layer as a frame-by-frame scratch pad memory.

SUMMARY OF THE INVENTION

Magnetic reading and writing of information in a virtually transparent magnetic layer in the
35 film during each stage of film use and film

-5-

processing is restricted to certain dedicated parallel tracks extending longitudinally along the length of the film, the choice of track being determined in accordance with the particular information being recorded. Magnetic reading/writing is performed with transport of the film by the camera during field use and during transport of the film by the dealer or photofinisher during film processing, printing, etc. The tracks are dedicated by universal pre-arrangement to certain sets of parameters or information, each set being of particular interest to a certain stage in the use of the film, the various stages including the camera, the dealer order entry station, the photofinisher order entry station, the classifier, the printer, the inspection or re-classifier station and the enveloper-sorter station.

The photofinisher tracks occupy the principal image area of each frame, so as to maximize the number of tracks available to the photofinisher and to render the format of these tracks virtually immune to any differences between various film formats or film perforation patterns. The photofinisher tracks therefore have a universally applicable format for use not just in photofinishing but also in film-to-video players, electronic print processing, etc.

The camera tracks are present only in film adapted for use in cameras having magnetic read/write capability. For this purpose, the camera tracks are accommodated along the film edges, without impacting the photofinisher track locations, by interruption of the usual film perforation pattern along the film edges. In the preferred embodiment, each perforation is located next to the

-6-

image area while the camera tracks are located next to the image area along the film edges between successive perforations.

All data is magnetically recorded on the
5 film using a novel self-clocking code which is completely self-clocking, in order to provide automatic data synchronization between the various users without requiring any of them to transport the film at the same speed or even at a uniform speed
10 when reading and writing. The self-clocking code is a single channel comprising a succession of uniform clocking pulses with intervening data transition pulses. The temporal placement of each data transition pulse relative only to the two clocking
15 pulses which immediately precede it and follow it, respectively, determines whether that transition pulse corresponds to a binary one or zero. Thus, film transport velocity changes between the recording of successive binary bits have no effect
20 upon the information content of the self-clocking encoded data. More importantly, differences in film transport velocity between data recording and data playback have no effect upon the readability of the self-clocking encoded data.

25 In a preferred embodiment of the invention, the various types of information are allocated among the dedicated tracks in accordance with groups of related information types or parameters, some individual groups being used by more than one stage
30 of the film use cycle. Furthermore, in this preferred embodiment, information common to all frames of the film is in dedicated tracks on the film leader. Specifically, information common to all frames, such as film type, camera type, owner
35 identification, a directory of written information

-7-

and the like are recorded in a first camera track (near one film edge) on the film leader. This first camera track is designated track C0 while the film leader is designated frame 0. Scene related parameters automatically sensed by the camera (such as scene luminance, camera orientation, color temperature, flash fire, etc.) are recorded in track C0 in each subsequent frame (e.g. frames 1-25). A second camera track, track C1, is dedicated to the recording of secondary information, such as shutter speed, aperture size, etc. Clearly, an intelligent photofinishing classifier station, in attempting to compute the optimum exposure conditions to make a print, would read the data on track C0 in each of frames 1 through 24 (for example), while a finishing station, in attempting to maintain correspondence between a customer's film and his order form or envelope, would read the data on track C0 in frame 0. A similar sort of allocation of photofinisher dedicated tracks is employed, with customer print order request data being recorded in a first photofinisher track (F0) in frame 0, process data such as image classification and number of prints made by frame in track F01, frames 1-25 (for example). Any makeover correction is recorded in track F02. A summary of makeover data (e.g. total number of makeover prints) is recorded in track F2 in frame 0. Other photofinisher tracks may be dedicated to uses other than photofinishing, such as frame-by-frame user instructions for film-to-video players or the like.

Solution to the Problems

The invention solves the problem of attaining data synchronization at all stages of film use without requiring that each stage transport the

-8-

film at constant velocity nor even at the same
velocity while recording or playing back data. The
invention achieves this without requiring the
recording of an extra space-wasting clocking track
5 simultaneously with the data track. Instead, the
representation of the binary state of a particular
bit is unaffected by the film transport speed during
recording and playback and is self-clocking. This
representation uniquely depends upon the temporal
10 relationship between each data transition pulse and
its immediately preceding and succeeding clock
pulses in the serial pulse train comprising the
self-clocking code. In the preferred embodiment, a
one bit is represented by a data transition pulse
15 which is closer to the preceding clock pulse. For
a zero bit, the data transition pulse is closer to
the succeeding clock pulse.

The invention solves the data access problem
faced by (among others) the photofinisher of
20 "finding a needle in a haystack" because each stage
need merely know which track has been dedicated to
the data relevant to that stage, and may read the
data from that track while ignoring all other data
magnetically recorded on the film. Furthermore, in
25 some cases the reading of data can be dispensed with
entirely in order to make certain basic
determinations about the film, by simply determining
whether certain tracks are empty or not. For
example, whether a particular strip of film has
30 already been developed (and therefore was submitted
for print re-order) is readily determined by seeing
whether or not certain tracks (e.g. track F1 of
frames 1 - 24) contain recorded data or not.

DESCRIPTION OF THE DRAWINGS

35 The invention may be understood by

-9-

reference to the accompanying drawings, of which:

Fig. 1 is a diagram illustrating the parallel dedicated tracks in a virtually transparent magnetic layer on film having a special perforation format particularly adapted for use in cameras having a magnetic film read/write capability;

Fig. 2 is a simplified diagram illustrating the concept of a camera adapted to read or write data on the film of Fig. 1;

Fig. 3 is a diagram illustrating the parallel dedicated tracks in a virtually transparent magnetic layer on film having the currently ubiquitous perforation format used in ordinary cameras not having a magnetic film read/write capability;

Fig. 4 is a diagram illustrating the accommodation of film wander in the camera of Fig. 2 by the use of different head widths at the various stages of film use;

Fig. 5 is a block diagram illustrating the architecture of a read only memory containing a directory of track locations for various parameters which may be magnetically written or read on the film, in accordance with the dedicated track format of Fig. 1;

Fig. 6 is a diagram illustrating the preferred data format used in the dedicated tracks of Fig. 1 or Fig. 3;

Fig. 7 illustrates an exemplary data identification code table for universal use with the data format of Fig. 6 by all stages of film use including camera and photofinisher;

Fig. 8 illustrates an exemplary symbol table for universal use with the data format of Fig. 6 by all stages of film use including camera and

-10-

photofinisher;

Fig. 9 illustrates an exemplary reserved control symbol table for universal use with the data format of Fig. 6 by all stages of film use including camera and photofinisher;

Fig. 10 is a block diagram illustrating a photofinishing system having magnetic read/write hardware including automated protocols which use the film of Figs. 1 or 3 as a scratch pad memory for increased efficiency or performance;

Fig. 11 illustrates a typical operator's keyboard used in the photofinishing system of Fig. 10 to classify developed negatives for correct print exposures;

Figs. 12a and 12b illustrate the form of the self-clocking code used in the invention;

Fig. 13 illustrates the use of each start and stop sentinel character and its compliment to facilitate film reversal sensing;

Figs. 14a and 14b illustrate the type of film reversal which is best detected using the invention; and

Fig. 15 is a simplified block diagram illustrating a self-clocking encoding/decoding on-film magnetic recording system.

DETAILED DESCRIPTION OF THE INVENTION

Preferred Format of the Dedicated Tracks on Film

Referring to Fig. 1, a strip 100 of color negative film 35 millimeters wide includes a base 110, various well-known photo-chemical layers 115 on one side of the base 110 and a virtually transparent magnetic layer 120 on the other side. An anti-static and lubricating layer 122 overlies the magnetic layer 120. The film strip 100 includes perforations 125 spaced along the film edge at

-11-

regular intervals matching the pitch of a metering pawl in a camera adapted to use the film strip 100.

For purposes of recording data in the magnetic layer 120, each frame of the film strip 100 is divided into a plurality of predetermined parallel longitudinal track locations where magnetic tracks of data may be recorded. Each of the tracks is preferably labeled as shown in Fig. 1. In particular, the two outermost tracks along each edge of the film strip 100 are tracks C0, C1 and tracks C2, C3, respectively. The thirty innermost tracks are tracks F00 through F29. Each one of the outermost tracks C0 through C3 is dedicated to the recording of a particular type of information by a camera having magnetic recording capability, in accordance with a pre-arrangement universally established for all cameras and photofinishers. In a similar manner, each one of the innermost tracks is dedicated to the recording of a particular type of information by a particular type of photofinishing (or other) equipment, in accordance with the above-referenced universal pre-arrangement.

In order to accommodate the presence of the camera tracks C0 through C3 along the film strip edges, the perforations 125 are excluded from periodic imperforate edge regions 100a adjacent each exposed frame and are restricted to intermediate regions 100b lying between subsequent frames. In the embodiment of Fig. 1, there is only one perforation in each intermediate region 100b. In the preferred embodiment, the perforations lie along only one longitudinal edge of the film strip 100.

Use of Dedicated Film Tracks in a Camera

Referring to Fig. 2, a camera 200 transports the film strip 100 between the reels

-12-

205a,b, of a film cartridge and a take-up sprocket, respectively, conforming to the format of the perforations 125 of Fig. 1. The camera 200 includes a magnetic read/write head 210 in near proximity
5 with the magnetic layer 120 on the unsensitized side of the film strip 100. A microprocessor 215 controls magnetic data recording or playback by the head 210 through head electronics 220.

The microprocessor 215 may accept order
10 information to be magnetically recorded on the film strip 100 from the camera user through camera controls 225, such information pertaining to the number of prints desired for a given frame, by frame number, for example, or the name and address of the
15 camera user for ultimate use by the photofinisher. The microprocessor 215 may also accept scene related information from scene sensors 230 to be magnetically recorded on the film strip 100 for ultimate use by the photofinisher. Such information
20 may include camera orientation, scene luminance and the like.

Film-Velocity Independent Data Code

Using the dedicated track on film format of Fig. 1, data is recorded by either a camera, an
25 order entry station, the photofinisher or any other stage of film use, by converting the data into binary bits and then encoding the binary data using a unique self-clocking code. Such self-clocking encoding is performed in accordance with the
30 teachings of U.S. Patent Application Serial Number 206,646 filed June 14, 1988 by Michael Wash entitled "Method for Modulating a Binary Data Stream" and assigned to the assignee of the present application, the disclosure of which is incorporated herein by
35 reference.

-13-

The self-clocking code described in the referenced patent application is briefly summarized here with reference to Fig. 12 of the accompanying drawings. The code comprises a serial stream of pulse edge transitions of a first type (e.g. positive-going edge transitions) and those of a second type (e.g. negative-going edge transitions) in alternating sequence. The first type pulse transitions serve as clock indicators while the second type serve as binary data indicators. A binary one is indicated in Fig 12a by a second type pulse transition 1215 which is temporally closer to the immediately preceding first type pulse transition 1205 and farther from the succeeding first type pulse transition 1210. A binary zero is indicated in Fig. 12b by a second type pulse transition 1215' temporally closer to the succeeding first type pulse transition 1210 than to the preceding one. With this novel self-clocking code, film transport velocity can vary during recording and playback without affecting the ability to synchronize and read the recorded data. Thus, the camera of Fig. 2 may record data while winding the film between exposures without imposing any velocity controls or recording an independent clock track.

The self-clocking code of Fig. 12 facilitates the automatic detection of film reversal. For this purpose, two six-bit characters from the table of reserved characters of Fig. 9 are chosen as the start and stop sentinels, respectively, recorded at the beginning and end of each frame in each dedicated track, in a manner described herein with reference to Fig. 6. Furthermore, the compliments of the two symbols thus chosen are also reserved, as indicated in Fig. 13,

-14-

the latter two reserved symbols comprising a film-reversed start sentinel and a film-reversed stop sentinel. This arrangement exploits a property of the self-clocking code of Fig. 12 in which
5 self-clocking data played back backwards (by transporting the film past the head in the direction opposite from that in which it was transported earlier during recording) results in its complement being decoded.

10 Thus, if the film image of Fig. 14a corresponds to the orientation of the film during the magnetic recording of data on the film by the camera for example, and if Fig. 14b corresponds to the orientation of the film as it is spliced and
15 loaded into photofinishing equipment having magnetic read/write capability, the film reversed stop sentinel will be detected, followed by the film reversed start sentinel, with every frame of data. Such film-reversed start and stop sentinels serve as
20 flags to notify the photofinisher that the film has been rotated as indicated in Fig. 14b. If the film has been turned inside out instead, the technique of Fig. 13 does not create a flag. However, such an error is easily detected, since it causes the
25 opposite side of the film to face the photofinisher's magnetic heads, thus increasing the distance between the heads and the magnetic layer 120 of Fig. 1, resulting in a decrease in signal-to-noise ratio.

30 Fig. 15 illustrates a simple example of a magnetics on film self-clocking read/write system useful in the camera 200 of Fig. 2.

The advantage of the longitudinal dedicated track format of Fig. 1 is that magnetic recording of
35 data on the film strip 100 may be performed by the

-15-

camera using a relatively stationary head (i.e. the head 210) by buffering all of the data to be recorded in a particular frame in a particular camera track and then transmitting the data to the head just as the film is being wound to the next frame.

The microprocessor 215 includes a read only memory 240 containing instructions sufficient to ensure that each type of information received is recorded in the correct one of the dedicated camera tracks C0 - C3 in accordance with a universal pre-arrangement common to both the camera and the photofinisher. For this purpose, the microprocessor sorts and buffers each piece of information in compliance with the instructions stored in the read only memory 240. The nature of this pre-arrangement and the architecture of the read only memory will be described below in this specification.

Dedicated Tracks Format for Ordinary

20 Cameras and Film

The format of the photofinisher tracks F00 through F29 is the same regardless of the placement of the film perforations 125 of Fig. 1. Thus, a photofinisher may employ the same magnetic recording protocols and hardware on all types of film provided that a virtually transparent magnetic layer (such as the layer 120 of Fig. 1) is added to all types of film. Thus, referring to Fig. 3, ordinary 35 mm color negative film having the now-standard pattern of closely spaced perforations along both film edges accommodates the photofinisher tracks F00 through F29 having the same width and spacing as that of the special film format of Fig. 1. Although the perforations of Fig. 3 preclude the presence of the camera tracks C0 through C3, such film is not used

-16-

in cameras having magnetic read/write capabilities and so the camera tracks need not be present. The advantage here is that all subsequent users of the film (i.e. photofinisher, film-to-video player, etc.) have been allocated the maximum number of tracks for all film formats, including those of Fig. 1 and of Fig. 3.

Camera and Photofinisher Dedicated Track Widths

Referring to Fig. 4, the width of the camera dedicated tracks C0 - C3 is greater than that of the photofinisher tracks F00 - F29. Of course, these track widths are controlled by the selection of the camera head widths and the photofinisher head widths. Preferably, the difference is sufficient to accommodate film wander in the camera during winding of the film while recording is performed by the head 210. Such wandering causes the camera tracks to have the meandering appearance illustrated in Fig. 4. Note in Fig. 4 that the photofinisher head, which must read the camera tracks, does not leave the camera track because it has a much smaller width.

Allocation of the Dedicated Tracks

Fig. 5 illustrates the allocation of the dedicated tracks, among the various information types, implemented by microcodes stored in the read only memory 240 of Fig. 2. There are four camera tracks and fifteen photofinisher tracks in each frame of the film exposed by the camera, these frames being designated frames 1 through 25. The film leader and trailer are designated frames 0 and 26, respectively. In general, the information recorded in frames 0 and 26 pertains to the film strip 100 as a whole, while the information recorded in each of frames 1 through 25 is unique for a

-17-

particular frame. In Fig. 5, three of the four camera tracks are used by the camera, while three of the thirty photofinisher tracks are used by the photofinisher. The rest of the photofinisher tracks are reserved for the recording of film-to-video player instructions (track F03), electronic print processing instructions (track F04) and audio (track F05 through F14). The remaining tracks (F15 - F29) are reserved for unforeseen purposes.

Each of the tracks is dedicated to a particular group of information types which would in most cases be written or read together. Thus, frame 0 track C0 is reserved for information relating to the owner and the camera for recording by the camera. Similarly, frame 0 track F00 is reserved for information relating to the owner and the photofinisher for recording by the photofinisher. Likewise, track F00 of frame 0 is reserved for recording by the photofinisher--or by an order entry station--of the customer's instructions, the film type, and related information pertaining to the treatment of the order. Track F02 of frame 0 is reserved for the recording of historical information regarding the location of frames requiring makeover prints and print reorders by the customer, for use by the photofinisher during a subsequent print reorder by the customer.

Track C0 of each exposed frame (frames 1-25) is reserved for scene-related information for recording by the camera, such as scene luminance, camera orientation and the like. Similarly, track F01 is reserved for photofinisher information unique to a particular exposed frame such as the classification of the negative image (determination of the proper print exposure), number of prints

-18-

made, etc. Any makeover correction to the classification is recorded in track F02.

The embodiment of Fig. 5 does not take into account all of the information types which may be magnetically recorded by the camera, retail order station or photofinisher on the film. However, the embodiment of Fig. 5 is an example of the manner in which all information types may be classified as to which track each one is to be assigned. The principle underlying the manner in which each information type is assigned to a particular track is that all information related to a particular transaction should be recorded on the same track, so that that track is dedicated to being written or read during those operations associated with that transaction.

The various transactions provided for in the embodiment of Fig. 5 are: (a) recording of customer data, including the customer address; (b) recording of scene-related information with each exposure, including parameters characterizing lighting conditions and camera exposure settings; (c) recording by the retail order station or photofinisher of customer order information, such as the number of prints desired; (d) the recording of inspection and makeover classification correction for a given frame by the photofinisher; (e) the recording of a summary of makeover data or print reorder data applicable to the entire film roll; (f) the recording of instructions for a film to video player; (g) the recording of instructions for electronic print processing; and (h) the recording of audio. In general (but not always) each of the magnetic recording tracks illustrated in Fig. 1 is dedicated to one of the foregoing transactions (a)

-19-

through (h). The result is that during recording the amount of searching for an available recording location is minimized while during playback the amount of searching through data irrelevant for a particular operation is also minimized. For example, during the classification operation, in which the optimum print exposure condition for each frame is determined, all scene-related information potentially helpful in determining the proper classification may be obtained by reading data from a single track, namely the camera-dedicated track C0 in each exposed frame (frames 1-25). No other track need be read.

Preferred Data Architecture

As previously described herein with respect to Fig. 1, the data recorded magnetically on the film strip 100 is divided into frames exposed by the camera (frames 1-25) as well as the film leader (frame 0), the data within each frame being allocated among a plurality of dedicated tracks within the frame. Fig. 6 illustrates the preferred data format within each track of each frame.

In Fig. 6, each track 600 has the length of one frame and is divided into a plurality of fields 610. Each track 600 includes a predicate start sentinel 615 at its beginning end (the left-hand edge of the track in Fig. 6 where the head begins its scanning of the track 600) and a stop sentinel 640 at its end. Each field includes a predicate ID sentinel 620 followed immediately by an ID code 625. The purpose of the track start sentinel 615 is to notify the read/write system in the camera or in the photofinishing hardware of the beginning location of the track 600. The purpose of the field ID sentinel 620 is to notify the same system of the

-20-

beginning location of each succeeding field in the track 600. The purpose of the ID code 625 is to identify the type of information recorded in the following field. In the preferred embodiment of the invention, each start sentinel 615 is preceded by a start sync mark 616 and each end sentinel 640 is followed by a stop sync mark 641. The marks 616, 641 enable special circuitry described in U.S. Patent Application Serial No. 255,578 filed herewith by Michael J. Wash and entitled "DATA ALIGNMENT CIRCUIT AND METHOD FOR SELF-CLOCKING ENCODED DATA", to achieve proper synchronization under adverse conditions described therein.

The ID code is recorded in the beginning of each field and is determined by the information type which follows it. For example, if the camera 200 of Fig. 2 is about to record the level of scene luminance observed by sensors on the camera during exposure of the frame, the camera first causes a unique ID code to be recorded just ahead of the data representing the scene luminance level. In the simplest embodiment, a unique ID code is assigned to each parameter or information type which may be recorded on the film, so that the ID codes for all possible information types constitute a large dictionary. Inasmuch as the same dictionary must be employed by all stages in the life cycle of the film (e.g., camera, photofinisher, etc.), identical read only memories are provided at each stage, each of these memories embodying a universal ID code dictionary and controlling the reading and writing of ID codes at each stage of film use.

The advantage is that the placement of a particular parameter within the track 600 by the camera need not be previously known by the

-21-

photofinisher in order for the photofinisher to be able to find that parameter on the track, since the photofinisher may simply refer to the corresponding ID code recorded by the camera. This same advantage
5 holds between any other separate components, where one component writes data onto the film and the other independently reads the data from the film at a later time and, typically, at a different location.

One exemplary embodiment of a universal ID
10 code dictionary is illustrated in Fig. 7. The dictionary of Fig. 7 is implemented as a set of microcodes stored in a read only memory 700 connected to the microprocessor of Fig. 2. The read only memory 700 of Fig. 7 defines a two-character ID
15 code for each parameter which may be recorded. In this embodiment, the ID codes start at AA and end at HI, as just one possible example. While Fig. 7 depicts each ID code as being associated with the name of a particular parameter, in practice each ID
20 code would be associated with the buffer or memory location of that parameter in the recording system so as to identify the corresponding data in terms of its location prior to being recorded. A system designer may use Fig. 7, for example, to construct
25 the actual machine language content of the read only memory 700, depending upon the particular system design employed.

The binary bits recorded for each alphanumeric symbol representing a particular piece
30 of information (e.g. scene luminance or customer address) or for one of the two-character ID codes of Fig. 7 are defined in accordance with the table of Fig. 8. The table of Fig. 8 is represented as a set of microcodes stored in a read only memory 800
35 connected to the microprocessor of 215. Each

-22-

alphanumeric symbol is represented by a pattern of six binary bits. The read only memory 800 defines a universal symbol dictionary which is used to perform reading and writing of data on the film at all stages of film use. The table of Fig. 8 is derived from the ASCII standard symbols.

The read only memory 800 also defines the six-bit patterns which are reserved for control purposes and which therefore may not be used for information or data. These reserved symbols are set forth in the exemplary table of Fig. 9, and include the control symbols illustrated in Fig. 6, including the start symbol 615a,b, the ID sentinel 620, a frame stop symbol 640a,b and the compliments of the start and stop sentinels 615 and 640. Other symbols are reserved in Fig. 9 in order to permit the skilled system designer to exercise other read or write controls as desired.

Referring again to Fig. 6, each data field ends with a six-bit parity character as shown. The first (most significant) two bits of the parity character are always 10, to prevent the parity character from assuming the value of any of the reserved characters of Fig. 9. The next bit is reserved for unforeseen purposes. The last (least significant) three bits provide single bit parity check for (a) the ID code of the field, (b) the remaining data characters in the field, and (c) the parity character itself, respectively. This format preserves the six-bit-per-byte boundary, even for the parity bits, thus simplifying the task of reading recorded data. It imposes far less overhead than the well-known technique of including one parity bit per character.

In Fig. 2, the microprocessor 215 in the

-23-

camera 200, while referring to the read only memory 240 for the track locations of the various allowed parameters, must also refer to read only memories 200 and 800 for the universal ID code dictionary and
5 universal symbol dictionary in order that subsequent readers of the data recorded by the camera 200 may properly interpret the data.

Implicit Mid Roll Interrupt Protection Code For Camera

10 Referring to Fig. 9, by reserving the six-bit character "[" as the ID sentinel 620 used by the film manufacturer only and "<" as the ID sentinel for all other users (camera, photofinisher, etc.), the camera of Fig. 2 can always detect the
15 film frame (position) of the next unexposed frame by simply searching for the ID sentinel "<" at the beginning of any camera track. Preferably, the camera's processor 215 of Fig. 2 is programmed with instructions to do just that each time a film
20 cartridge is loaded.

Exemplary Use of Dedicated Tracks in Photofinishing

Use of the dedicated film tracks for magnetic recording of information by a camera has
25 been described with reference to the example of Fig. 2. Fig. 10 illustrates one example of the use of the dedicated film tracks (of either Fig. 1 or Fig. 3) for magnetic reading and writing in a photofinishing system. In general, such a
30 photofinishing system employs its own version of the read only memories 240, 700, 800 for track location, an ID code dictionary and a symbol dictionary.

In Fig. 10, the film strip 100 is removed from the cartridge (or at least partially extracted
35 to expose its leader--frame 0) at an order entry

-24-

station 910. The order entry station 910 may be located either at the dealer or at the photo-finishing laboratory. The order entry station has a magnetic read/write system including a head 910a and
5 a controller (microprocessor) 915 which executes an order entry algorithm stored in memory 925. This algorithm defines the correct track locations in frame 0 for the recording of customer-related information, including the number of prints desired,
10 the customer's name and address, etc., entered in at a terminal 920 or read directly from one of the camera tracks. A developer 927 develops the film strip 100 to form a negative image in each exposed frame.

15 The film strip 100 then enters a classifier 930 which determines the optimum print exposure condition for each frame on the film strip 100. The classifier may do this either manually under control of a human operator or automatically using an image
20 sensor such as is done in the Eastman Kodak 3510 Color Printer or in the Eastman Kodak CLAS 35 Color Printer. An exemplary manual control terminal included in the manual version of the classifier 930 is illustrated in Fig. 11. The luminance value at
25 which the photosensitive print paper is to be exposed through a given negative image may be changed from a nominal value (gray level) by arbitrary values -4 to +4 by pressing one of the appropriate buttons in the row of buttons labelled
30 "D" on the left side of the terminal of Fig. 11. The intensity of red, green and blue light at which the print paper is exposed may be altered from pre-defined nominal values in similar manner by arbitrary values -4 to +4 by pushing the appropriate
35 buttons in the corresponding one of the rows of

-25-

buttons labelled "R", "G" and "B", respectively. The resulting classification (defined by the luminance, red, green and blue print exposure values) is recorded by the classifier's magnetic
5 head 930a in the appropriate one of the dedicated tracks (in accordance with the track allocation defined in a read only memory such as the memory 240 of Fig. 5).

It should be noted that if data previously
10 recorded on the film strip 100 indicates that it has been previously developed and printed (so that a classification value is stored in each frame in the appropriate track), then the developer 927 and the classifier 930 are automatically bypassed.

15 A printer 940 receives the film strip 100, reads the classification previously recorded in each frame by the classifier 930, and exposes one frame in a roll of photosensitive paper 937 through the corresponding negative frame with an exposure whose
20 characteristics meet the recorded classification. The printer 940 includes its own magnetic read/write system, such as a magnetic head 940a, a controller 945 and a memory 950 storing a classifier/printer algorithm. This algorithm governs the magnetic
25 reading and writing by the printer 940 and classifier 930 in accordance with the dedicated tracks format of Fig 1 or Fig. 3. For example, the printer/classifier algorithm requires the controller
30 945 to determine whether camera tracks (tracks C0 through C3) were previously recorded on the film strip 100. If so, the dedicated track film format of Fig. 1 applies and scene-related information (if used by the classifier 930 to enhance the accuracy of the classification operation) may be found by
35 reading the appropriate track. Likewise, the

-26-

printer/classifier algorithm in the memory 950 tells the printer 940 where to find the classification value recorded in each frame by the classifier 930.

An operator at an inspection station views
5 each of the prints on the print roll 943 to determine whether a makeover print is required for any of them. Under control of a controller 965 which executes an inspection algorithm stored in a memory 970, data is recorded on the film strip 100
10 in the appropriate track by the inspection station's magnetic head 960a reflecting the necessity (if any) of a makeover print in a given frame. Presumably the makeover was necessitated by an incorrect classification, and a correction to the original
15 classification must be computed and recorded in the appropriate track on the film strip 100. In one embodiment, this is done by the inspection station 960 itself, while in another embodiment this is done at a separate re-classifier 975 having its own
20 magnetic recording head 975a and recording system for this purpose. The film strip 100--which may be included in a roll of many such film strips--is sent to a makeover printer 980, typically by transferring the entire roll. The makeover printer 980 has its
25 own magnetic read/write system, including magnetic head 980a, with which it may read the appropriate data in the appropriate tracks to determine which of the frames require makeover prints and, for each one of these, what the original classification value was
30 and what the classification correction is. From this information, the makeover printer exposes the appropriate frames on the film strip 100 using the corrected classification values.

A roll of makeover prints 983 produced by
35 the makeover printer 980, the roll of prints 943

-27-

produced by the printer 940 and the roll of developed film including the film strip 100 are all fed to a sorter 985. The sorter collates the individual original and makeover prints with the corresponding film strips into complete customer orders, discarding any original prints whenever corresponding makeover prints have been made. Whether a corresponding makeover print has been made is determined by the sorter 985 through its magnetic read/write system including a controller 987 which executes a sorter algorithm stored in a memory 990 and the sorter's magnetic head 985a. The head 985a is simply directed to read the required data from the appropriate one of the dedicated tracks on the film strip 100 by the controller 987, in accordance with the track allocation illustrated in Fig. 5.

Magnetic Heads For Multiple Tracks

Magnetically reading and writing data in a plurality of parallel magnetic tracks is a known technique in the field of magnetic tape recording and magnetic disk recording. One way is to use an array of stationary magnetic heads, one head for each track. Such an array is sold by Spin Physics, San Diego, California, as part number 203454. An invention for adapting such technology to magnetic recording on film is disclosed in U.S. Patent Application Serial No. 254,903, filed herein by Michael L. Wash, et al. entitled "Camera Apparatus for Magnetically Recording on Film", the disclosure of which is incorporated herein by reference.

While the invention has been described in detail by specific reference to preferred embodiments thereof, it is understood that other variations and modifications may be made without departing from the spirit and scope of the invention.

-28-

CLAIMS:

1. In an elongate photographic film strip susceptible of exposure of successive frames therein a camera having a magnetic writing system and for
5 developing and printing by photofinishing devices having a magnetic reading and writing system, the improvement comprising:
a virtually transparent magnetic layer; and
longitudinal parallel tracks magnetically
10 recorded in said magnetic layer, said tracks comprising three-part encoded data, whereby said film may be transported at different velocities with respect to magnetic writing and reading means in said camera and in said photofinishing devices while
15 permitting either to read the data previously recorded by the other.
2. The improvement of claim 1 wherein each of said tracks begins and ends within a particular frame, each of said tracks further comprising first
20 and second three-part encoded binary characters uniquely representing start and stop sentinels respectively.
3. In a photofinishing system which processes an elongate photographic film strip having
25 successive frames, the improvement wherein:
said film strip comprises a virtually transparent magnetic layer; and
wherein said photofinishing system
comprises:
30 means for writing and reading self-clocking encoded data in said magnetic layer so as to create longitudinal parallel photofinisher-dedicated tracks in each of said frames, and for placing a start sentinel character
35 and a stop sentinel character at the beginning and

-29-

end of each said track respectively, said characters each having a predetermined self-clocking encoded binary bit sequence.

4. The improvement of claim 3 wherein said
5 photofinishing means further comprises means for sensing whenever the compliment of either of said binary bit sequences is read from any of said tracks so as to sense whenever said film is transported in said photofinishing means in a longitudinal
10 direction opposite to that in which said tracks were previously recorded.

5. In a photofinishing system comprising:
(a) an elongate photographic film strip adapted to be loaded into a camera for exposure of successive
15 frames therein, and (b) photofinishing means for developing and printing said film strip after exposure by said camera, the improvement wherein:

said film strip comprises a virtually transparent magnetic layer; and

20 wherein said photofinishing system comprises:

means for sensing whether self-clocking data has previously been recorded in said magnetic layer as longitudinal parallel camera-dedicated
25 tracks;

means for recording self-clocking encoded data in said magnetic layer so as to create longitudinal parallel photofinisher-dedicated tracks in each of said frames, and for placing a start
30 sentinel character and a stop sentinel character at the beginning and end of each said track respectively, said characters each having a predetermined self-clocking encoded binary bit sequence.

35 6. The improvement of claim 5 wherein said

-30-

photofinishing means further comprises means for sensing whenever the compliment of either of said binary bit sequences is read from any of said tracks so as to sense whenever said film is transported in said photofinishing means in a longitudinal direction opposite to that in which said tracks were previously recorded.

7. The improvement of claim 1, further comprising a plurality of perforations through all of said layers, said perforations being located along at least one longitudinal edge of said film strip, the location of said perforations being characterized in that each of said successive frames is adjacent a longitudinal peripheral area along said one longitudinal film strip edge from which said perforations are excluded, wherein said tracks comprise:

longitudinal parallel camera-dedicated magnetic tracks recorded by said camera magnetic writing system in said magnetic layer within said longitudinal peripheral area along said one longitudinal film strip edge between successive ones of said perforations, said tracks comprising magnetic patterns representative of self-clocking encoded data; and

longitudinal parallel photofinisher-dedicated tracks recorded by said photofinisher magnetic write and read system in said magnetic layer within the camera-exposed area of each of said frames, said photofinisher-dedicated tracks comprising self-clocking encoded data, whereby said film may be transported at varying or different velocities with respect to magnetic writing or reading means in said camera and in said photofinishing devices while permitting either to

-31-

read the data previously recorded by the other.

5

10

15

20

25

30

35

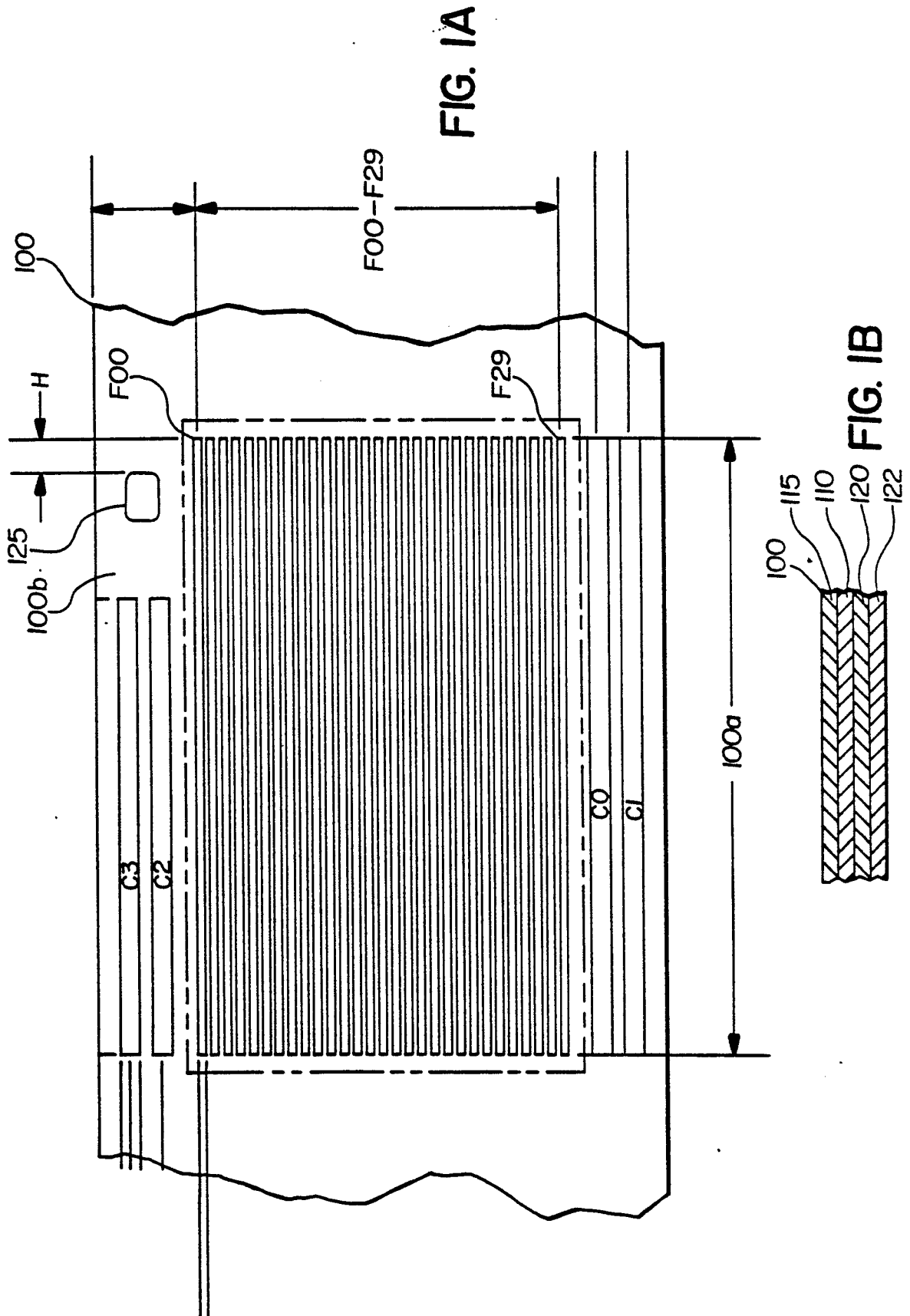

FIG. 1A

FIG. 1B

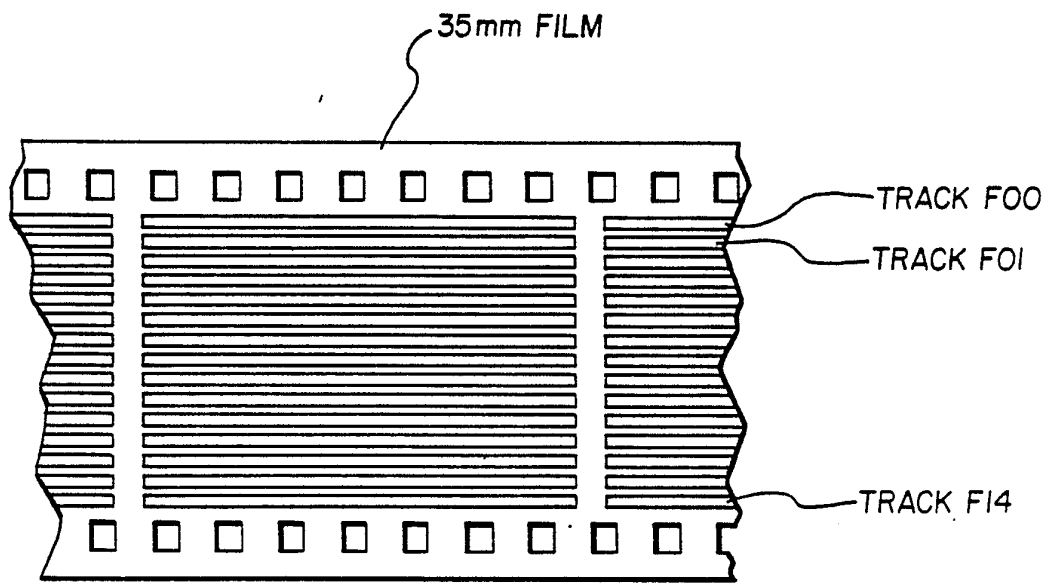

FIG. 3

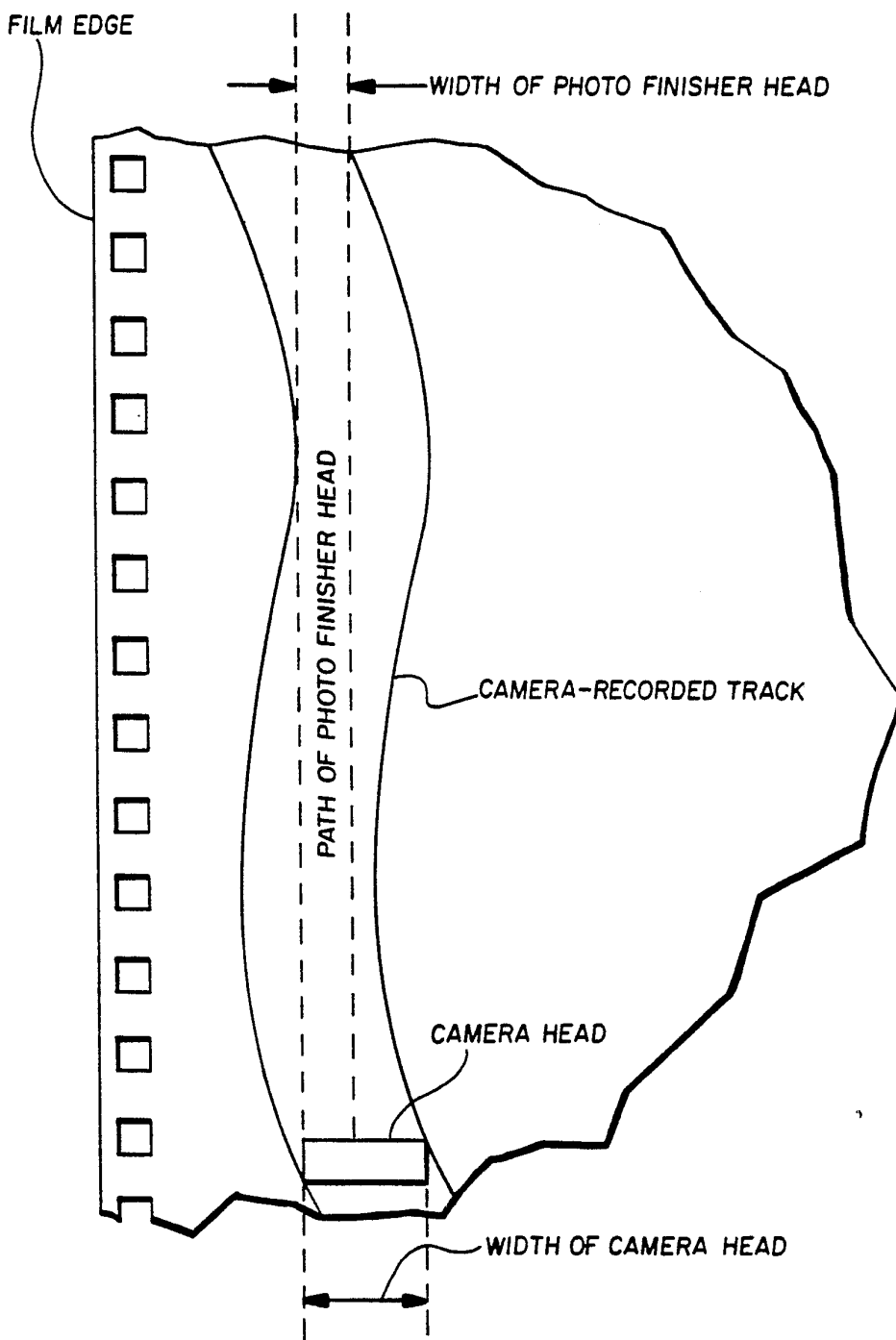

FIG. 4

| TRACK | FRAME 0, 26 | FRAME 1-25 |
|--------|---|---|
| Gen'l | FILM TYPE IDENT | |
| C0 | ID's -OWNER (20) -CAMERA (15) -CAMERA DEALER (20) -DIRECTORY OF WRITTEN INFORMATION | CAMERA PRIMARY -DATE -TIME (ACTUAL, ELAPSED) -ORIENTATION REVERSE WIND VS. FORWARD WIND CAMERA -LUMINANCE LEVEL -FLASH FIRE -SERIES SCENE -CAMERA ROLL # -CAMERA EXPOSURE # -FRAME # |
| C1 | CAMERA SECONDARY -EOS FEATURES | |
| C2 | USER INPUT | |
| F0 | ID's -OWNER (60) -P/F DEALER ID (20). -LAB (20) -USER INPUT FEATURE IND. -END OF ORDER FLAG | USER INPUT |
| F1 | INITIAL ORDER INFO -ORDER REQUEST -ROLL ID -FILM TYPE -COMPLETED ORDER INFO -CLASSIFICATION FLAG | PROCESS INFORMATION -CLASSIFICATION -INSPECTION INFORMATION -MAKEOVER CORRECTION -PRINTS MADE |
| F2 | REORDER/MAKEOVER INFO -ORDER REQUEST -ORDER TYPE (REO/MO) -COMPLETED ORDER INFO | PROCESS INFORMATION -PRINTS MADE |
| F3 | FILM-TO-VIDEO TRACK | |
| F4 | ELECTRONIC PRINT PROCESSING TRACK | |
| F5-F14 | RESERVED FOR AUDIO | |

FIG. 5

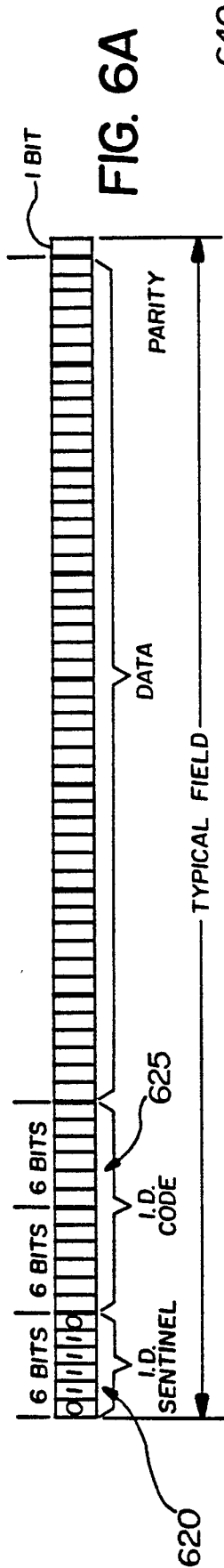

FIG. 6A

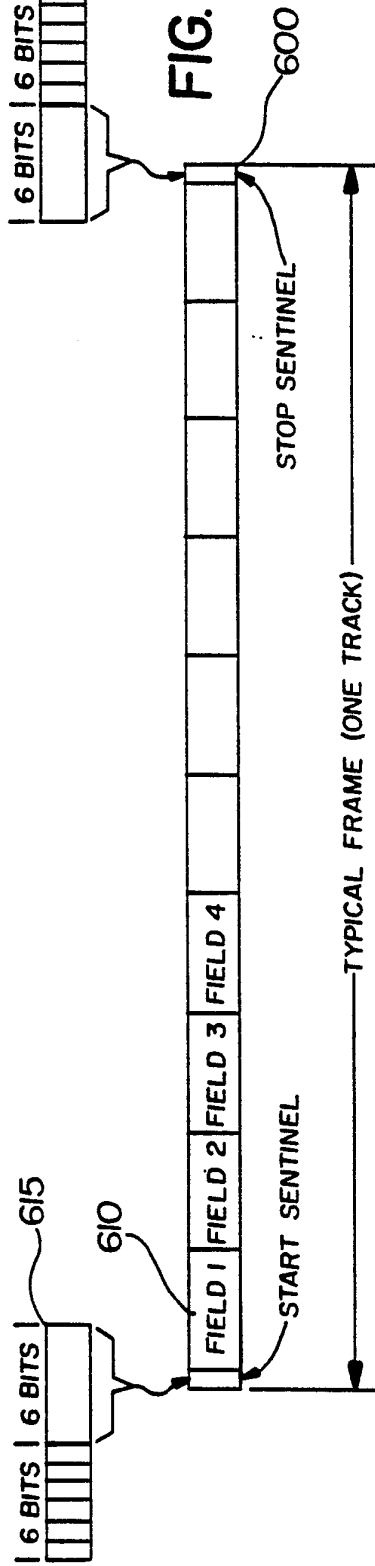

FIG. 6B

| I. D. TABLE | |
|--------------|-------------------|
| PARAMETER(S) | 12-BIT I. D. CODE |
| | |

| SYMBOL TABLE | |
|---------------------|-------------------|
| ALPHANUMERIC SYMBOL | SIX-BIT CHARACTER |
| | |

FIG. 6D

FIG. 6C

7/12

PRE-RECORDED BY CAMERA
(ON FILM)

| | |
|---|----|
| -CAMERA OWNER IDENTIFICATION | AA |
| -CAMERA IDENTIFICATION NO. | AB |
| -ISO USED BY CAMERA | AC |
| -DEALER ID | AD |
| -REVERSE WIND | AE |
| -SPECIAL USE INSTRUCTIONS, MRO, ETC. | AF |

RECORDED AT RETAIL ORDER
STATION

| | |
|------------------------------|----|
| -CUSTOMER IDENTIFICATION | GA |
| -ORDER ENTRY DATE/TIME | GB |
| -CUSTOMER CHARGE CARD NUMBER | GC |
| -RETAILER IDENTIFICATION | GD |
| -FRAME NUMBERS TO BE PRINTED | GE |
| -NUMBER PRINTS PER NEGATIVE | GF |
| -PRINT SIZE | GG |
| -MASK CHOICE | GH |
| -CROPPING INFORMATION | GI |
| -PAPER SURFACE FINISH | GJ |
| -ORDER RETURN DATE | GK |
| -METHOD OF RETURN | GL |
| -SPECIAL EFFECTS | GM |
| -SPECIAL SERVICES | GN |
| -PUSH PROCESS | GO |

RECORDED BY CAMERA AT
EACH FRAME (ON FILM)

| | |
|----------------------------------|----|
| -METERING FIDUCIAL | BA |
| -DATE OF EXPOSURE | BB |
| -TIME OF EXPOSURE | BC |
| -CAMERA ORIENTATION | CA |
| -f NUMBER | CB |
| -SHUTTER SPEED | CC |
| -FOCAL LENGTH | CD |
| -FLASH FIRE | CE |
| -FLASH RETURN | CF |
| -FILL FLASH RATIO | CG |
| -BACKLIT SCENE INDICATOR | CH |
| -EXPOSURE BIAS | CI |
| -SERIES SCENE | CJ |
| -ILLUMINANT COLOR TEMPERATURE | CK |
| -LUMINANCE RANGE | CL |
| -LUMINANCE LEVEL | CM |
| -SUBJECT DISTANCE | CN |
| -BEYOND CAMERA EXPOSURE RANGE | CO |
| -BEYOND MINIMUM SHUTTER RANGE | CP |
| -PSEUDO FORMAT-(TELE/PAN) | DA |
| -SCENE CLASSIFICATION | DB |
| -REVERSE WIND CAMERA | DC |
| -TEMPERATURE | DD |
| -USER INPUT | EA |
| -IDENTIFY PRINCIPAL SUBJECT | EB |
| -SUBJECT MOTION | EC |
| -CAMERA MOTION | ED |
| -STANDARD EXPOSURE | EE |
| -CAMERA FRAME NUMBER | FA |
| -CAMERA ROLL NUMBER | FB |
| -PUSH PROCESS | FC |
| -FRAME NUMBER | FD |
| -ELAPSED TIME | FE |

RECORDED AT PHOTOFINISHER

| | |
|---------------------|----|
| PF DEALER ID | HA |
| LAB ID | HB |
| END OF ORDER FLAG | HC |
| CLASSIFICATION FLAG | HD |
| CLASSIFICATION | HE |
| MAKEOVER FLAG | HF |
| MAKEOVER CORRECTION | HG |
| UNSALVAGEABLE FLAG | HH |
| NO. OF PRINTS MADE | HI |

FIG. 7

FIG. 8

| <u>CHARACTER</u> | <u>G-BIT BYTE</u> | | | | | |
|------------------|-------------------|---|---|---|---|---|
| 0 | 0 | 1 | 0 | 0 | 0 | 0 |
| 1 | 0 | 1 | 0 | 0 | 0 | 1 |
| 2 | 0 | 1 | 0 | 0 | 1 | 0 |
| 3 | 0 | 1 | 0 | 0 | 1 | 1 |
| 4 | 0 | 1 | 0 | 1 | 0 | 0 |
| 5 | 0 | 1 | 0 | 1 | 0 | 1 |
| 6 | 0 | 1 | 0 | 1 | 1 | 0 |
| 7 | 0 | 1 | 0 | 1 | 1 | 1 |
| 8 | 0 | 1 | 1 | 0 | 0 | 0 |
| 9 | 0 | 1 | 1 | 0 | 0 | 1 |
| A | 1 | 0 | 0 | 0 | 0 | 1 |
| B | 1 | 0 | 0 | 0 | 1 | 0 |
| C | 1 | 0 | 0 | 0 | 1 | 1 |
| D | 1 | 0 | 0 | 1 | 0 | 0 |
| E | 1 | 0 | 0 | 1 | 0 | 1 |
| F | 1 | 0 | 0 | 1 | 1 | 0 |
| G | 1 | 0 | 0 | 1 | 1 | 1 |
| H | 1 | 0 | 1 | 0 | 0 | 0 |
| I | 1 | 0 | 1 | 0 | 0 | 1 |
| J | 1 | 0 | 1 | 0 | 1 | 0 |
| K | 1 | 0 | 1 | 0 | 1 | 1 |
| L | 1 | 0 | 1 | 1 | 0 | 0 |
| M | 1 | 0 | 1 | 1 | 0 | 1 |
| N | 1 | 0 | 1 | 1 | 1 | 0 |
| O | 1 | 0 | 1 | 1 | 1 | 1 |
| P | 1 | 1 | 0 | 0 | 0 | 0 |
| Q | 1 | 1 | 0 | 0 | 0 | 1 |
| R | 1 | 1 | 0 | 0 | 1 | 0 |
| S | 1 | 1 | 0 | 0 | 1 | 1 |
| T | 1 | 1 | 0 | 1 | 0 | 0 |
| U | 1 | 1 | 0 | 1 | 0 | 1 |
| V | 1 | 1 | 0 | 1 | 1 | 0 |
| W | 1 | 1 | 0 | 1 | 1 | 1 |
| X | 1 | 1 | 1 | 0 | 0 | 0 |
| Y | 1 | 1 | 1 | 0 | 0 | 1 |
| Z | 1 | 1 | 1 | 0 | 1 | 0 |
| SPACE | 0 | 0 | 0 | 0 | 0 | 0 |
| = | 0 | 1 | 1 | 1 | 0 | 1 |
| \$ | 0 | 0 | 0 | 1 | 0 | 0 |
| - | 0 | 0 | 1 | 1 | 0 | 1 |
| . | 0 | 0 | 1 | 1 | 1 | 0 |
| / | 0 | 0 | 1 | 1 | 1 | 1 |

| | | | | | | | | | |
|---|---|---|---|---|---|---|---|---|---|
| ! | 0 | 0 | 0 | 0 | 0 | 0 | 0 | 1 | FILM REVERSED START SENTINEL (FIRST CHARACTER) |
| " | 0 | 0 | 0 | 0 | 0 | 1 | 0 | | |
| # | 0 | 0 | 0 | 0 | 1 | 1 | 1 | | |
| % | 0 | 0 | 0 | 1 | 0 | 1 | | | |
| & | 0 | 0 | 0 | 1 | 1 | 0 | | | |
| ' | 0 | 0 | 0 | 1 | 1 | 1 | 1 | 1 | END SENTINEL (FIRST CHARACTER) AND FILM-REVERSED VERSION OF SAME |
| (| 0 | 0 | 1 | 0 | 0 | 0 | | | |
|) | 0 | 0 | 1 | 0 | 0 | 1 | | | |
| * | 0 | 0 | 1 | 0 | 1 | 0 | | | |
| + | 0 | 0 | 1 | 0 | 1 | 1 | | | |
| , | 0 | 0 | 1 | 1 | 0 | 0 | | | |
| : | 0 | 1 | 1 | 0 | 1 | 0 | | | |
| ; | 0 | 1 | 1 | 0 | 1 | 1 | | | |
| < | 0 | 1 | 1 | 1 | 0 | 0 | | | ID SENTINEL (USED BY ALL EXCEPT MFG.) |
| > | 0 | 1 | 1 | 1 | 1 | 0 | | | |
| ? | 0 | 1 | 1 | 1 | 1 | 1 | 1 | 1 | START SENTINEL (FIRST CHARACTER) |
| @ | 1 | 0 | 0 | 0 | 0 | 0 | 0 | 0 | FILM REVERSED 2ND CHARACTER OF START SENTINEL AND END SENTINEL |
| [| 1 | 1 | 1 | 0 | 1 | 1 | 1 | 1 | ID SENTINEL (USED ONLY BY FILM MFG) |
| \ | 1 | 1 | 1 | 1 | 0 | 0 | | | |
|] | 1 | 1 | 1 | 1 | 0 | 1 | | | |
| ^ | 1 | 1 | 1 | 1 | 1 | 0 | | | START SENTINEL (2ND CHARACTER) AND END SENTINEL (2ND CHARACTER) |
| _ | 1 | 1 | 1 | 1 | 1 | 1 | 1 | 1 | |

FIG. 9

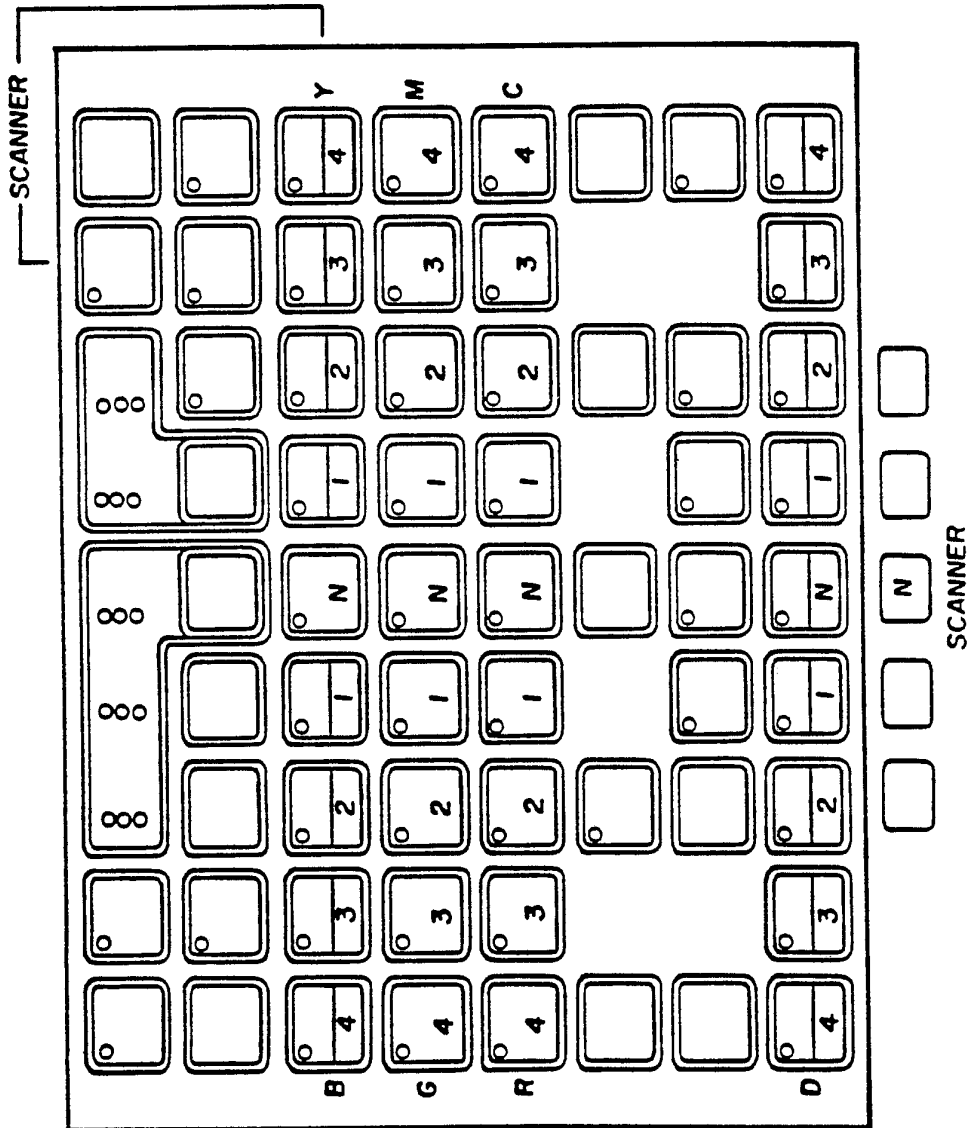

FIG. 11

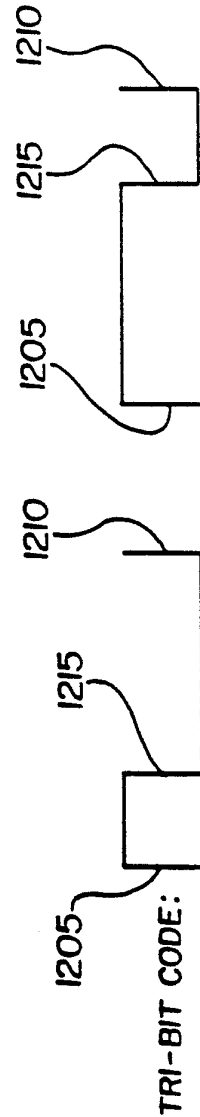
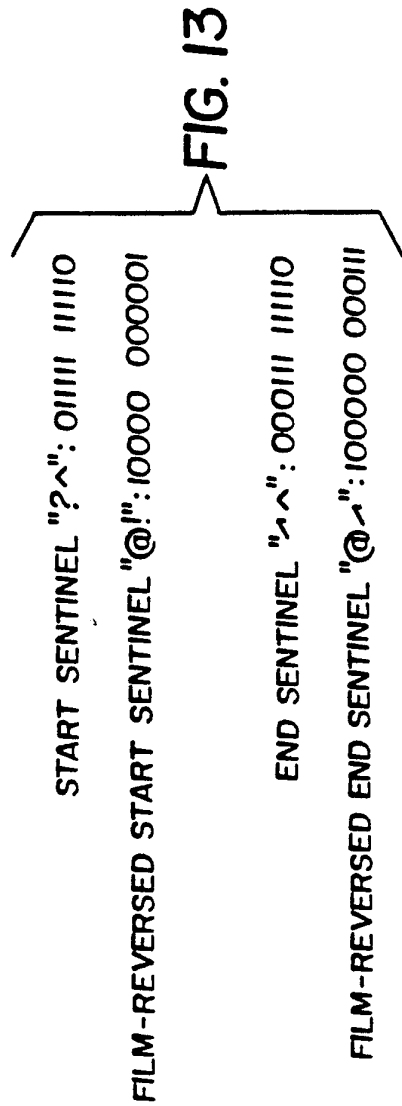
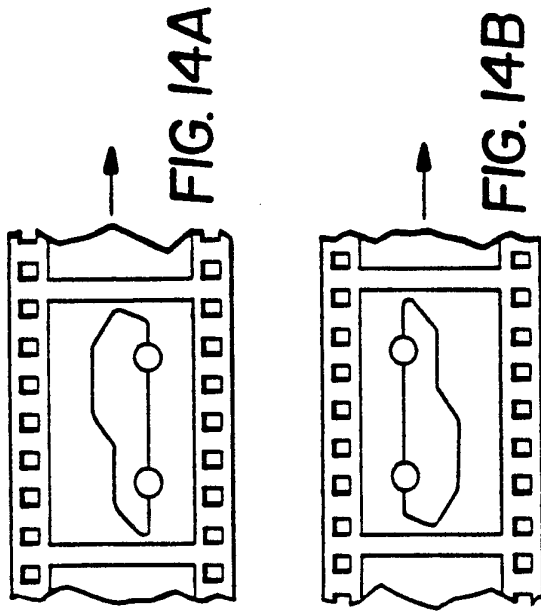

FIG. 12A

FIG. 12B

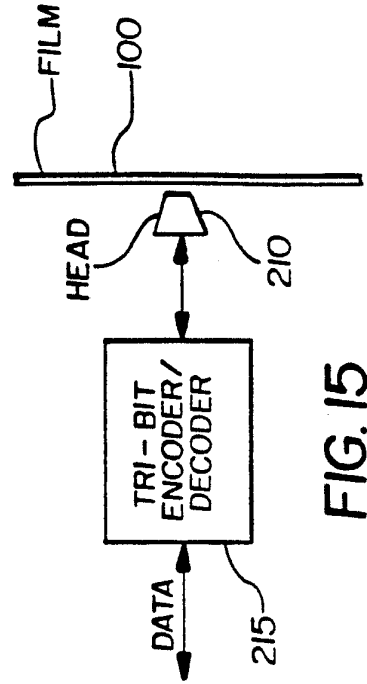
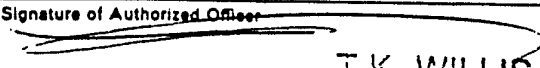

FIG. 15

INTERNATIONAL SEARCH REPORT

International Application No PCT/US 89/04362

| I. CLASSIFICATION OF SUBJECT MATTER (if several classification symbols apply, indicate all) ⁶ | | |
|--|--|-------------------------------------|
| According to International Patent Classification (IPC) or to both National Classification and IPC | | |
| IPC5: G 11 B 23/44 | | |
| II. FIELDS SEARCHED | | |
| Minimum Documentation Searched ⁷ | | |
| Classification System | Classification Symbols | |
| IPC5 | G 03 B; G 11 B | |
| Documentation Searched other than Minimum Documentation to the Extent that such Documents are Included in the Fields Searched ⁸ | | |
| | | |
| III. DOCUMENTS CONSIDERED TO BE RELEVANT ⁹ | | |
| Category ¹⁰ | Citation of Document, ¹¹ with Indication, where appropriate, of the relevant passages ¹² | Relevant to Claim No. ¹³ |
| Y | US, A, 3782947 (H.J. KRALL) 1 January 1974, see abstract | 1 |
| A | -- | 3,4,5,7 |
| Y | US, A, 3379095 (E.K. KAPRELIAN) 23 April 1968, see figures 2-8 | 1 |
| A | -- | 2 |
| A | EP, A2, 0011086 (EASTMAN KODAK COMPANY) 28 May 1980, see figures 3-5 | 3,5,6,7 |
| A | -- | |
| A | US, A, 4054920 (KITTAG) 18 October 1977, see the whole document | 1 |
| | -- | |
| <p>¹⁰ Special categories of cited documents:</p> <p>"A" document defining the general state of the art which is not considered to be of particular relevance</p> <p>"E" earlier document but published on or after the international filing date</p> <p>"L" document which may throw doubts on priority claim(s) or which is cited to establish the publication date of another citation or other special reason (as specified)</p> <p>"O" document referring to an oral disclosure, use, exhibition or other means</p> <p>"P" document published prior to the international filing date but later than the priority date claimed</p> <p>"T" later document published after the international filing date or priority date and not in conflict with the application but cited to understand the principle or theory underlying the invention</p> <p>"X" document of particular relevance; the claimed invention cannot be considered novel or cannot be considered to involve an inventive step</p> <p>"Y" document of particular relevance; the claimed invention cannot be considered to involve an inventive step when the document is combined with one or more other such documents, such combination being obvious to a person skilled in the art.</p> <p>"Δ" document member of the same patent family</p> | | |
| IV. CERTIFICATION | | |
| Date of the Actual Completion of the International Search | Date of Mailing of this International Search Report | |
| 11th January 1990 | 22 JAN. 1990 | |
| International Searching Authority | Signature of Authorized Officer | |
| EUROPEAN PATENT OFFICE |  T.K. WILLIS | |

| III. DOCUMENTS CONSIDERED TO BE RELEVANT (CONTINUED FROM THE SECOND SHEET) | | |
|--|--|----------------------|
| Category * | Citation of Document, with indication, where appropriate, of the relevant passages | Relevant to Claim No |
| A | FR, A, 2295453 (CLERICI JEAN-PIERRE ET AL) 16 July 1976, see figure 1 | 1 |
| | -- | |
| A | US, A, 4251156 (ZIMMERMANN ET AL) 17 February 1981, see abstract | 3-6 |
| | -- | |
| A | US, A, 4441807 (BARTZ) 10 April 1984, see abstract | 3-6 |
| | -- | |
| A | US, A, 4443099 (LINMAN ET AL) 17 April 1984, see abstract | 3-6 |
| | -- | |
| | ----- | |

ANNEX TO THE INTERNATIONAL SEARCH REPORT
ON INTERNATIONAL PATENT APPLICATION NO. PCT/US 89/04362

SA 31714

This annex lists the patent family members relating to the patent documents cited in the above-mentioned international search report.
The members are as contained in the European Patent Office EDP file on 08/11/89
The European Patent Office is in no way liable for these particulars which are merely given for the purpose of information.

| Patent document cited in search report | Publication date | Patent family member(s) | Publication date |
|--|------------------|---|----------------------------------|
| H.-J- 3782947 | 01/01/74 | NONE | |
| US-A- 3379095 | 23/04/68 | NONE | |
| EP-A2- 0011086 | 28/05/80 | JP-A- 55022799 US-A- 4340286 | 18/02/80 20/07/82 |
| US-A- 4054920 | 18/10/77 | DE-A- 2604159 AT-A-B- 346704 JP-A- 51104304 | 19/08/76 27/11/78 16/09/76 |
| FR-A- 2295453 | 16/07/76 | NONE | |
| US-A- 4251156 | 17/02/81 | DE-A-C- 2933252 CH-A- 632347 | 21/02/80 30/09/82 |
| US-A- 4441807 | 10/04/84 | NONE | |
| US-A- 4443099 | 17/04/84 | NONE | |

EPO FORM P0079

For more details about this annex : see Official Journal of the European Patent Office, No. 12/82