



(51) International Patent Classification:

A61N 2/02 (2006.01) B82Y 5/00 (2011.01)  
A61N 2/06 (2006.01) G01R 33/383 (2006.01)  
A61N 2/12 (2006.01)

(21) International Application Number:

PCT/US2019/059096

(22) International Filing Date:

31 October 2019 (31.10.2019)

(25) Filing Language:

English

(26) Publication Language:

English

(30) Priority Data:

62/755,660 05 November 2018 (05.11.2018) US

(71) Applicant: **BIONAUT LABS LTD.** [IL/IL]; 1 Arie Shenkar Street, 4672514 Herzliya (IL).

(72) Inventors; and

(71) Applicants (for US only): **SHPIGELMACHER, Michael** [IL/US]; 2719 Westwood Blvd., Los Angeles, California 90064 (US). **SROMIN, Alexander** [—/IL]; 12, Malakhi Ha-Navi St., 7747628 Ashdod (IL). **CAPUTO, John** [—/US]; 222 S. Main Street, Apt. 1422, Los Angeles, California 90012 (US). **OREN, Eran** [IL/IL]; 8 Geiger Street, 6934160 Tel Aviv (IL). **VAN CLEVE, Eli** [—/US];

1948 Malcolm Ave., Apt. 103, Los Angeles, California 90025 (US). **COHEN, Nadav** [—/IL]; Hubert Humphrey 232, 3547008 Haifa (IL). **GERON, Amir** [—/IL]; Migdal Oz Street, 7/30, 7170328 Modi'in (IL). **SEELY, Dennis** [—/US]; P.O. Box 910452, San Diego, California 92191 (US). **KISELYOV, Alex** [US/US]; 4203 Shorepointe Way, San Diego, California 92130 (US).

(74) Agent: **COHEN, Mark** et al.; Pearl Cohen Zedek Latzer Baratz LLP, 1500 Broadway, 12th Floor, New York, New York 10036 (US).

(81) Designated States (unless otherwise indicated, for every kind of national protection available): AE, AG, AL, AM, AO, AT, AU, AZ, BA, BB, BG, BH, BN, BR, BW, BY, BZ, CA, CH, CL, CN, CO, CR, CU, CZ, DE, DJ, DK, DM, DO, DZ, EC, EE, EG, ES, FI, GB, GD, GE, GH, GM, GT, HN, HR, HU, ID, IL, IN, IR, IS, JO, JP, KE, KG, KH, KN, KP, KR, KW, KZ, LA, LC, LK, LR, LS, LU, LY, MA, MD, ME, MG, MK, MN, MW, MX, MY, MZ, NA, NG, NI, NO, NZ, OM, PA, PE, PG, PH, PL, PT, QA, RO, RS, RU, RW, SA, SC, SD, SE, SG, SK, SL, SM, ST, SV, SY, TH, TJ, TM, TN, TR, TT, TZ, UA, UG, US, UZ, VC, VN, ZA, ZM, ZW.

(84) Designated States (unless otherwise indicated, for every kind of regional protection available): ARIPO (BW, GH, GM, KE, LR, LS, MW, MZ, NA, RW, SD, SL, ST, SZ, TZ,

(54) Title: MAGNETIC PROPULSION SYSTEM FOR MAGNETIC DEVICES

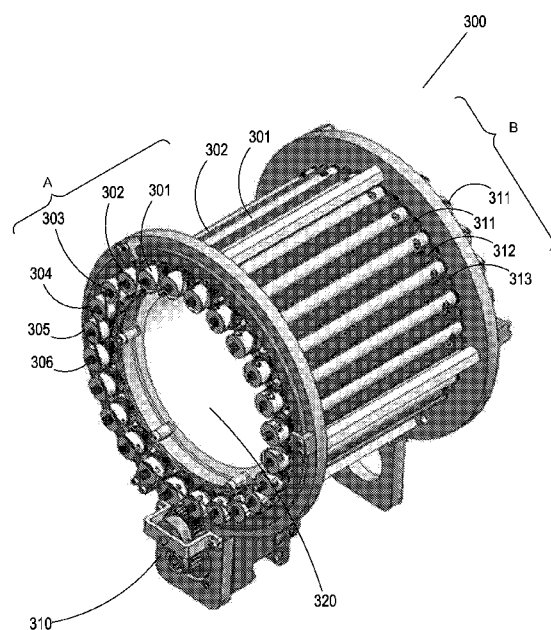

FIG. 3

(57) Abstract: This invention relates to apparatus for creating a magnetic field to propel a magnetic device within a diverse media including biological matrices, tissues, organs, animals and humans. In one embodiment, a cylindrical dual Halbach array provides a uniform magnetic field with a settable field direction. Another embodiment provides support and orientation apparatus for a controlled-gradient conical magnet to achieve a full  $4\pi$  steradian solid angle coverage around the specimen.



UG, ZM, ZW), Eurasian (AM, AZ, BY, KG, KZ, RU, TJ, TM), European (AL, AT, BE, BG, CH, CY, CZ, DE, DK, EE, ES, FI, FR, GB, GR, HR, HU, IE, IS, IT, LT, LU, LV, MC, MK, MT, NL, NO, PL, PT, RO, RS, SE, SI, SK, SM, TR), OAPI (BF, BJ, CF, CG, CI, CM, GA, GN, GQ, GW, KM, ML, MR, NE, SN, TD, TG).

**Published:**

- *with international search report (Art. 21(3))*
- *before the expiration of the time limit for amending the claims and to be republished in the event of receipt of amendments (Rule 48.2(h))*

## MAGNETIC PROPULSION SYSTEM FOR MAGNETIC DEVICES

### RELATED APPLICATIONS

[001] This application is related to U.S. Provisional Patent Application Serial No. 62/697,044, filed July 12, 2018, titled “MAGNETIC PROPULSION SYSTEM FOR MAGNETIC DEVICES,” and U.S. Provisional Patent Application Serial No. 62/666,536, filed May 3, 2018, titled “HYBRID ELECTROMAGNETIC DEVICE FOR REMOTE CONTROL OF MICRO-NANO SCALE ROBOTS, MEDICAL TOOLS AND IMPLANTABLE DEVICES,” each of which is incorporated by reference herein in its entirety.

### FIELD

[002] This invention relates to apparatus for creating a magnetic field to externally propel a magnetic device within a matrix of material, such as a viscous medium in a biological tissue.

### BACKGROUND

[003] In many medical applications, it can be useful to have a miniaturized mobile device (herein denoted as a “*bot*”) to move in a medium such as found in a biological organism. For example, it may be desirable to move an internal device through tissue to a particular anatomic location to release a drug, gather diagnostic data, or conduct a remote-controlled surgical procedure. To facilitate such movement, propulsion and navigation utilizing magnetic fields has been developed.

[004] One mode of propulsion involves applying an external uniform rotating magnetic field on internal device located inside the body. According to this mode, the internal device has a helical or a related shape (screw-like) exhibiting asymmetry and it comprises an embedded magnet with diametric magnetization. Rotating the external field exerts congruent rotational torque on the device, propelling it forward (like a screw). It is expected that reversing the external rotational field direction will yield a respective reverse particle dynamics. This propulsion method is denoted as “rotation.”

[005] Another propulsion mode involves applying an external non-uniform magnetic field (a “magnetic gradient”) performing increasing strength along a controllable line (a “gradient line”) to an internal device located inside the body. The device includes an embedded magnet or a metallic component. In response to the external field gradient, the device moves along

the gradient lines generated by the external magnet. This propulsion method is denoted as “gradient-based motion.”

[006] A combination of the two above propulsion techniques are required to properly propel the bot through the tissue as each propulsion mode impacts the bot differently.

[007] It is worth noting that the same magnetic system can be used to control other types of functionality of the bot remotely using a combination of magnetic field rotation and/or magnetic gradient, applied at a predefined time at a particular configuration, in parallel or separately from the propulsion of the bot. For example, in one embodiment the bot may contain an internal magneto-mechanic mechanism which extrudes a particular payload to the surrounding matrix in response to a predefined magnetic gradient or a predefined rotation of the external magnetic field generated by the magnetic system.

### SUMMARY

[008] Various embodiments of the present invention provide external apparatus that establishes a variable magnetic field to manipulate a bot, for example, to propel a bot through a matrix of interest or to expel or deliver a payload from the bot into a matrix of interest. Such a matrix of interest includes, but is not limited to, a media, extracellular matrix, a compartment, tissue, organ, blood, lymph, biliary or cerebrospinal fluid in the region of the magnetic field.

[009] The term “*magnet*” herein denotes any object having a magnetic field. In particular, a combination of individual magnets, including an “*array*” of individual magnets is herein itself considered a “magnet”. In some descriptions herein, a distinction is made between an “individual magnet” and an “array of magnets”, but it is understood that an “array of magnets” is also considered to be a “magnet”.

[0010] The term “*propel*” herein denotes the causing of any kind of physical motion, including, but not limited to: rotation, translation, vibration, oscillation, and combinations thereof.

[0011] The term “*creating and manipulating a magnetic field*” herein denotes making any changes to a magnetic field in a region, including, but not limited to: introducing a magnetic field into the region; moving a magnetic field from one place to another; and varying the intensity, flux, direction, and/or polarity of a magnetic field in the region.

[0012] According to certain embodiments, the external apparatus includes features such as:

[0013] a permanent field magnet;

[0014] multiple permanent field magnets;

[0015] an array of permanent field magnets arranged in a particular topological fashion to meet requirements such as: a specific field strength, field gradient/directionality as a function of distance, and trajectory away from the array.

[0016] An array of magnet may also include electromagnets which may or may not be composed of copper, aluminum or superconducting material exemplified by but not limited to NbTi.

[0017] An array according to a related embodiment is affixed, directly or indirectly, to a structural member, including but not limited to a platform, support, bracket, orienting apparatus, disk or other defined surface.

[0018] In another related embodiment, the magnet or array of magnets is attached to a mobility device having a motor to provide motion of the magnet or array, non-limiting examples of such motion including: rotation, cyclic motion (angular regular or irregular “rocking”; translational oscillation; and other such motion); vibration; trajectory motion (such as orbitally-circling a region); and combinations thereof.

[0019] As noted previously, a device according to various embodiments of the invention moves a bot via a torque, a linear force, and/or combinations thereof, wherein the torques and linear forces are applied via a magnetic field established by permanent magnets and arrays and / or electro-magnets which are prepared and arranged as disclosed herein.

[0020] According to certain embodiments, the function of torque applied to a bot is to overcome friction of the bot against surrounding media (such as diverse matrices, biological tissues and compartments) or other propulsion resistance forces, while the linear force propels the bot through the media itself. A rotating magnetic field perpendicular to the direction of bot motion provides torque on the bot, while a controlled gradient of that same field amplitude along the direction of desired bot motion, provides a linear attractive force on the bot.

[0021] According to an embodiment of the present invention, there is provided a system for creating and manipulating a magnetic field to propel a magnetic device in a specimen, the system comprising: (a) a cylindrically-disposed plurality of rod shaped or related magnets enclosing a hollow space to include the analyte, matrix, subject or specimen of interest, each rod magnet thereof having a transverse magnetization; (b) wherein the plurality of rod shaped or related magnets form an array including but not limited to a Halbach array which

includes: (c) a first array of rod magnets; and (d) a second array of rod magnets; (e) wherein the first array of rod magnets and the second array of rod magnets are interleaved in an alternating fashion such that magnets from the first array always have magnets from the second array as their nearest neighbors; (f) and could be manipulated to: (g) alter positioning of all the magnets of the first array; and (h) alter positioning of all the magnets of the second array; (i) wherein the dynamics of the magnets of the first array is independent of the dynamics of the magnets of the second array.

[0022] In addition, according to another embodiment of the present invention, there is further provided a device for creating and manipulating a magnetic field to propel a magnetic device in a specimen including but not limited to an *ex vivo* matrix, biological specimen as exemplified by blood, lymph, bile, spinocerebral fluid, tissue, organ or compartment, the device comprising: (a) a magnet for creating the magnetic field; (b) a stage for holding the specimen; (c) support and orienting apparatus for the magnet, to which the magnet is attached; (d) support and orienting apparatus for the stage, to which the stage is attached; and (e) at least one positioning drive apparatus containing a motor; (f) controlling mechanism, wherein: (g) the support and orienting apparatus for the magnet includes at least a first rotatable offset bracket; and (h) the support and orienting apparatus for the stage includes at least a second rotatable offset bracket; (i) wherein the second rotatable offset bracket is rotated according to a position of the first rotatable offset bracket, so as to allow the first rotatable offset bracket to rotate to any angular position without having the magnet blocked by the second rotatable offset bracket, (j) such that the system is operative to orient the magnet over a solid angle of  $4\pi$  steradians with respect to the stage.

[0023] In addition, so far as the embodiment of the previous device, in which the stage holding the specimen may also be placed inside the magnet and the magnet may therefore be rotated  $4\pi$  steradians with respect to the stage.

[0024] The current embodiments of the invention have the current advantages: (a) Gradient to mediate reliable, reproducible motion at considerable distances, (b) Versatility in a combination with mechanical component: 2D/3D options, (c) Feasible size, safety, modular nature, applicability to studies of diverse matrices including animals, (c) Ability to accommodate i) diverse particles, ii) imaging, iii) delivery and retraction, iv) other (micro)devices used in (micro)manipulation including microsurgery, (d) Facile integration into a platform along with other modules.

### BRIEF DESCRIPTION OF THE DRAWINGS

[0025] The subject matter regarded as the invention is particularly pointed out and distinctly claimed herein. Embodiments of the invention, however, both as to organization and method of operation, together with objects, features, and advantages thereof, may best be understood by reference to the following detailed description when read with the accompanying drawings in which:

[0026] Fig. 1A illustrates a magnet on a yoke, according to an embodiment of the invention.

[0027] Fig. 1B is an isometric view of the magnet on a yoke of Fig. 1A.

[0028] Fig. 2 illustrates a pair of similar magnets having a predetermined angular displacement, according to an embodiment of the invention.

[0029] Fig. 3 illustrates a cylindrical arrangement of Halbach arrays, with a dual independent synchronizing mechanism, according to an embodiment of the present invention.

[0030] Fig. 4 is an isometric view of a conical magnet according to an embodiment of the present invention.

[0031] Fig. 5A illustrates a support mounting and orienting apparatus for the conical magnet of Fig. 4, according to an embodiment of the present invention.

[0032] Fig. 5B illustrates a stage for a specimen under investigation (SUI), and accompanying support and positioning apparatus, according to an embodiment of the present invention, for use with the conical magnet and support mounting and orienting apparatus of Fig. 5A.

[0033] Fig. 6A illustrates the conical magnet support mounting and orienting apparatus of Fig. 5A in conjunction with the SUI stage and support and positioning apparatus of Fig. 5B, with the conical magnet oriented behind the SUI, according to an embodiment of the invention.

[0034] Fig. 6B illustrates the configuration of Fig. 6A as arranged with the conical magnet oriented below the SUI, according to an embodiment of the invention.

[0035] Fig. 6C illustrates the configuration of Fig. 6A as arranged with the conical magnet oriented in front of the SUI, according to an embodiment of the invention.

[0036] Fig. 6D illustrates the configuration of Fig. 6A as arranged with the conical magnet oriented above the SUI, according to an embodiment of the invention.

[0037] Fig. 6E illustrates the configuration of Fig. 6A as arranged with the conical magnet oriented to the left of the SUI, according to an embodiment of the invention.

[0038] Fig. 6F illustrates the configuration of Fig. 6A as arranged with the conical magnet oriented in front of the SUI, according to an embodiment of the invention.

[0039] Fig. 6G illustrates the configuration of Fig. 6A as arranged with the conical magnet oriented to the right of the SUI, according to an embodiment of the invention.

[0040] It will be appreciated that for simplicity and clarity of illustration, elements shown in the figures have not necessarily been drawn to scale. For example, the dimensions of some of the elements may be exaggerated relative to other elements for clarity. Further, where considered appropriate, reference numerals may be repeated among the figures to indicate corresponding or analogous elements.

### DETAILED DESCRIPTION

[0041] In the following detailed description, numerous specific details are set forth in order to provide a thorough understanding of the invention. However, it will be understood by those skilled in the art that the present invention may be practiced without these specific details. In other instances, well-known methods, procedures, and components have not been described in detail so as not to obscure the present invention.

[0042] Fig. 1A illustrates a permanent bar magnet **101** mounted on a disk-shaped ferromagnetic yoke **102** according to an embodiment of the invention. In related embodiments, yoke **102** takes other shapes. According to further embodiments of the invention, yoke material is steel. In still other embodiments, bar magnet **101** is a stack of individual magnets. Fig. 1B shows an isometric view of bar magnet **101** on yoke **102**.

[0043] Fig. 2 illustrates a magnet **201** in proximity to a similar magnet **202**, wherein the two magnets have a predetermined angular displacement  $\theta$  **203**. In a related embodiment, the angular displacement  $\theta$  is  $60^\circ$ , which in some cases maximizes the field strength for magnets of a given weight and composition.

[0044] Fig. 3 illustrates a cylindrical arrangement **300** of Halbach arrays, with a dual independent synchronizing mechanism, according to an embodiment of the present invention, to make and use a system for creating and manipulating a magnetic field to propel a magnetic device in a specimen. In this embodiment, arrangement **300** has two independent Halbach arrays, herein denoted as array A and array B, respectively. Each element of a

Halbach array is in the form of a rod shaped or alternative magnet having a transverse magnetization, so that rotating a magnet changes the direction of its magnetic field. The term “rod magnet having a transverse magnetization” herein denotes a rod-shaped or related magnet, being a cylinder like object whose length is greater than its diameter, and whose magnetic field lines lie substantially in planes orthogonal to the axis of the said cylinder, such that the poles of the magnet are on the curved exterior surfaces of the cylinder. The magnets are cylindrically-disposed to enclose a hollow space **320**, which can accommodate a specimen treated with a nano or micro device featuring magnetic properties. The magnets of the two arrays are interleaved, as shown for two representative samplings in Fig. 3. Rod or rod like magnets **301**, **302**, **303**, **304**, **305**, and **306** belong to array A, whereas rod or rod like magnets **311**, **312**, and **313** belong to array B, and the two arrays are interleaved, such that every magnet of array A lies between two magnets of array B, and every magnet of array B lies between two magnets of array A. In Fig. 3, array A magnets are shown as light-colored, whereas array B magnets are shown as dark colored. For the sake of illustration, a motor drive **310** moves the gears that rotate all array A magnets simultaneously, and independently rotate all array B magnets in a related fashion, for example simultaneously. The gear drives for array B are on the back side of Halbach array **300**, and are related in construction to those of array A, which are visualized in Fig. 3. The Halbach array of Fig. 3 establishes a relatively uniform field in internal space **320**.

[0045] Fig. 4 illustrates a conical magnet **401** with a hollow internal space **402**, according to an embodiment of the invention. In a related embodiment, conical magnet **401** is made of individual segments, one of which is shown as a segment **403**. According to these embodiments, magnet **401** is characterized by a 3-dimensional gradient, and specimens can be placed inside of the resulting hollow internal space **402**.

[0046] One of the key features provided by embodiments of the present invention is the ability to position magnet **401** at any desired location around a specimen, and to move magnet **401** continuously in any trajectory from that location to any other location. Mathematically, this requires being able to move magnet **401** continuously over a complete solid angle of  $4\pi$  steradians. The described dynamics is accomplished by the apparatus shown in Fig. 5A, and 5B; and illustrated in different arrangements providing  $4\pi$  steradian coverage in Fig. 6A through Fig. 6G. In related embodiments of the invention, motion over

the  $4\pi$  steradian range includes cyclic motion, rocking, vibration, oscillation, and other repetitive movement.

[0047] In the following description, a system for positioning and orienting a magnet to propel a magnetic device in a specimen is described and illustrated for clarity in the specific case of a conical magnet. It is understood that this is a non-limiting example; in related embodiments, the same apparatus is used to position and orient other magnetic devices, including, but not limited to magnets of other shapes and having other field distributions, and arrays of magnets.

[0048] It is also contemplated that devices with a magnetic component for use in systems according to embodiments of the present invention will include devices described in International Patent Application PCT/US2018/030960 filed on May 3, 2018 and titled "METHODS AND SYSTEMS TO CONTROL PARTICLES AND IMPLANTABLE DEVICES," which is hereby incorporated by reference in its entirety. Briefly, such devices with a magnetic component are microelectromechanical (MEM) devices, which comprise: (i) an actuator; (ii) a responsive element; (iii) a sensor; and (iv) an electronic circuit; wherein: said actuator controls and operates said responsive element; said electronic circuit controls said actuator; and said sensor receives signals transmitted by a remote unit. It is also contemplated that systems according to embodiments of the present invention will be included in the platforms described in International Patent Application PCT/US2018/030960. Briefly, such platforms comprise the following modules: (a) one or more devices with a magnetic component and comprising embedded logic and various MEM components; (b) a delivery and/or retraction module, configured to deliver and/or retract the devices; (c) an external signal generator; (d) an imaging module, configured to monitor said particles; and (e) an integration module configured to receive inputs from and to provide output control commands to other modules; wherein: said modules are configured to interact/communicate with each other; and said modules are internally controlled, externally controlled or both; and wherein said platform provides active, pre-determined, fully controlled, precise delivery of said devices *in vitro*, *in vivo*, and/or in a patient.

[0049] Fig. 5A illustrates a support mounting and orienting apparatus for a conical magnet **501**, according to an embodiment of the present invention. An upper structural member **502** supports the entire weight of the apparatus and provides stability for the elements that hang from it. A rotatable offset bracket **503** pivots around a vertical axis **505**. The pivoting of

offset bracket **503** is provided by a positioning drive apparatus containing a motor (not shown), which is able to rotate offset bracket **503** around a vertical axis **505** to any desired angular position. Attached to offset bracket **503** is another rotatable offset bracket **504** which supports magnet **501** and pivots around a horizontal axis **515** to any desired angular position. The pivoting of rotatable offset bracket **504** is provided by another positioning drive apparatus containing a motor (not shown), which is able to rotate offset bracket **504** around horizontal axis **515** to any desired angular position.

[0050] Fig. 5B illustrates a support and positioning apparatus for a stage **506** upon which is placed a specimen under investigation (SUI) **507**. A rotatable offset bracket **508** supports stage **506**. Offset bracket **508** is attached to and supported by a plinth **512**, which is rotated by a positioning drive apparatus **510** containing a motor, which is able to rotate offset bracket **508** to any desired angle around vertical axis **505**. This is the same vertical axis **505** around which offset bracket **503** is rotated. That is, during operation, the apparatus of Fig. 5A is precisely aligned with the apparatus of Fig. 5B, such that offset brackets **503** and **508** both rotate simultaneously around vertical axis **505**. A freely-rotating connector **509** maintains a stationary angular orientation of stage **506** as offset bracket **508** rotates. The apparatus of Fig. 5B is supported and stabilized by a lower structural member **511**.

[0051] According to various embodiments of the present invention, offset brackets **503** and **508** provide support that is offset from vertical axis **505**, and offset bracket **504** provides support that is offset from horizontal axis **515**. This enables magnet **501** to be positioned directly in-line along both vertical axis **505** and horizontal axis **515**, without interference from any supporting members that would block magnet **501** from being positioned as desired. In this manner, magnet **501** covers the full  $4\pi$  steradian solid angle surrounding the specimen. According to these embodiments, the  $4\pi$  steradian solid angle coverage is readily achieved by rotating offset bracket **508** so that it is always oriented  $180^\circ$  opposite to the rotated angular position of offset bracket **503**. Meeting this orientation constraint guarantees that offset bracket **504** (to which magnet **501** is directly affixed) can be rotated to any angle around horizontal axis **515** without having magnet **501** blocked by offset bracket **508**. In certain embodiments of the invention, offset bracket **508** is continuously rotated synchronously with respect to offset bracket **503** so that the above orientation constraint is always met; in other embodiments, however, offset bracket **508** is rotated only when necessary to avoid blocking magnet **501** by offset bracket **508**.

[0052] The combination of magnet **501** with the above apparatus constitutes a system for creating and manipulating a magnetic field to propel a magnetic device in a specimen. The following discussion and drawings illustrate how such a combination can be constructed and used.

[0053] Fig. 6A through Fig. 6G illustrate how magnet **501** can be positioned to six polar positions – two on each of the three coordinate axes (*i.e.*,  $\pm x$ ,  $\pm y$ ,  $\pm z$ ). Note that there are multiple configurations that position magnet **501** in the same location. For example, Fig. 6C and Fig. 6F both position magnet **501** in the same location relative to the specimen, but with different but equivalent configurations. These polar positions are special cases, but it can readily be seen that this apparatus is capable of moving magnet **501** into any position relative to stage **506**, over a complete solid angle of  $4\pi$  steradians. That is, in spherical coordinates  $r$ ,  $\theta$ , and  $\varphi$ , apparatus according to these embodiments of the invention can position magnet **501** for any angular values of  $\theta$  and  $\varphi$ . According to certain embodiments,  $r$  is constant – and this condition is illustrated in Fig. 6A through Fig. 6G. In further embodiments, however,  $r$  can be varied somewhat by changing one or more of the  $x$ ,  $y$ ,  $z$  coordinates of stage **506**, and in related embodiments this is accomplished by including  $x$ - $y$ - $z$  control into the apparatus, non-limiting examples of which include introducing  $x$ - $y$ - $z$  control into the positioning of stage **506** and/or the positioning of plinth **512**.

[0054] Fig. 6A illustrates magnet **501** with the support mounting and orienting apparatus of Fig. 5A in conjunction with SUI stage **506** and support and positioning apparatus of Fig. 5B, with conical magnet **501** oriented behind the SUI, according to an embodiment of the invention.

[0055] Fig. 6B illustrates magnet **501** with the support mounting and orienting apparatus of Fig. 5A in conjunction with SUI stage **506** and support and positioning apparatus of Fig. 5B, with conical magnet **501** oriented below the SUI, according to an embodiment of the invention.

[0056] Fig. 6C illustrates magnet **501** with the support mounting and orienting apparatus of Fig. 5A in conjunction with SUI stage **506** and support and positioning apparatus of Fig. 5B, with conical magnet **501** oriented in front of the SUI, according to an embodiment of the invention. Compare with Fig. 6F, as described below, in light of the remarks above concerning multiple configurations for achieving the same orientation of magnet **501**.

[0057] Fig. 6D illustrates magnet **501** with the support mounting and orienting apparatus of Fig. 5A in conjunction with SUI stage **506** and support and positioning apparatus of Fig. 5B, with conical magnet **501** oriented above the SUI, according to an embodiment of the invention.

[0058] Fig. 6E illustrates magnet **501** with the support mounting and orienting apparatus of Fig. 5A in conjunction with SUI stage **506** and support and positioning apparatus of Fig. 5B, with conical magnet **501** oriented to the left of the SUI, according to an embodiment of the invention.

[0059] Fig. 6F illustrates magnet **501** with the support mounting and orienting apparatus of Fig. 5A in conjunction with SUI stage **506** and support and positioning apparatus of Fig. 5B, with conical magnet **501** oriented in front of the SUI, according to an embodiment of the invention. Compare with Fig. 6C, as described above, in light of the remarks above concerning multiple configurations for achieving the same orientation of magnet **501**.

[0060] Fig. 6G illustrates magnet **501** with the support mounting and orienting apparatus of Fig. 5A in conjunction with SUI stage **506** and support and positioning apparatus of Fig. 5B, with conical magnet **501** oriented to the right of the SUI, according to an embodiment of the invention.

## CLAIMS

### What is claimed is:

1. A system for creating and controlling a magnetic field to manipulate a device with a magnetic component in a specimen, the system comprising:  
a cylindrical or similar organization of rod or rod like magnets enclosing a hollow space for the specimen;  
wherein the plurality of magnets form a Halbach array which includes:  
a first array of magnets; and  
a second array of magnets; and  
and a motor drive operative to:  
rotate all the magnets of the first array; and  
rotate all the magnets of the second array.
2. The system of claim 1, wherein each magnet has a diametral magnetization.
3. The system of claim 1, wherein the first array of magnets and the second array of magnets are interleaved in an alternating fashion such that magnets from the first array always have magnets from the second array as their nearest neighbors.
4. The system of claim 1, wherein the rotation of the magnets of the first array is independent of the rotation of the magnets of the second array.
5. The system of claim 1, wherein the manipulation of the device with the magnetic component is propulsion of the device within the specimen.
6. The system of claim 1, wherein the manipulation of the device with the magnetic component is expulsion of a payload from the device into the specimen.
7. A system for creating and controlling a magnetic field to manipulate a device with a magnetic component in a specimen under investigation (SUI), the system comprising:  
a magnet for creating the magnetic field;  
a stage for holding the specimen;  
support and orienting apparatus for the magnet, to which the magnet is attached;

support and orienting apparatus for the stage, to which the stage is attached;  
and  
at least one positioning drive apparatus containing a motor;  
wherein the system is operative to orient the magnet over a solid  
angle of  $4\pi$  steradians with respect to the stage.

8. The system of claim 7, wherein the support and orienting apparatus for the magnet includes at least a first rotatable offset bracket.
9. The system of claim 8, wherein the support and orienting apparatus for the stage includes at least a second rotatable offset bracket.
10. The system of claim 9, wherein the second rotatable offset bracket is rotated according to a position of the first rotatable offset bracket, so as to allow the first rotatable offset bracket to rotate to any angular position without having the magnet blocked by the second rotatable offset bracket.
11. The system of claim 7, wherein the SUI may be inserted inside the magnet and the magnet may be rotated  $4\pi$  steradians with respect to the SUI is inside the magnet.
12. The system of claim 7, further comprising a control system that integrates all components and allows for both an operational and a diagnostics interface.
13. The system of claim 7, wherein the magnet is a conical or related shape magnet (e.g., pyramid, trapezoid).
14. The system of claim 7, wherein the manipulation of the device with the magnetic component is propulsion of the device within the specimen.
15. The system of claim 7, wherein the manipulation of the device with the magnetic component is expulsion of a payload from the device into the specimen.

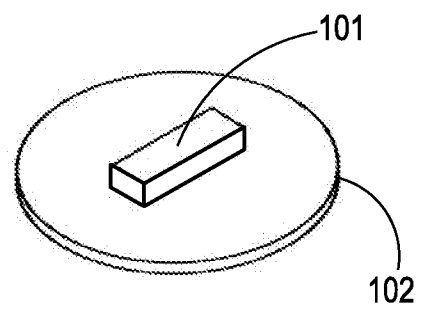
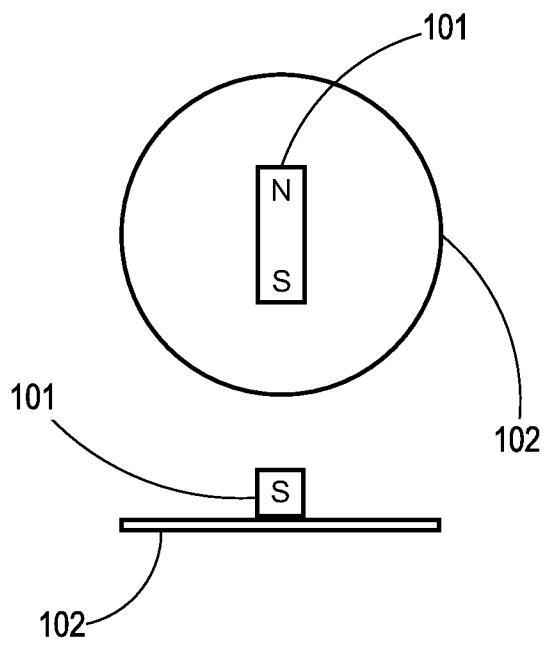

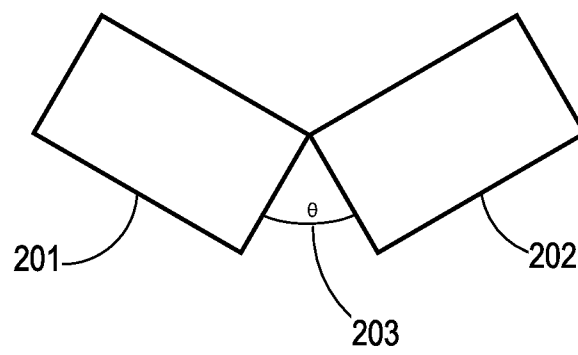

FIG. 2

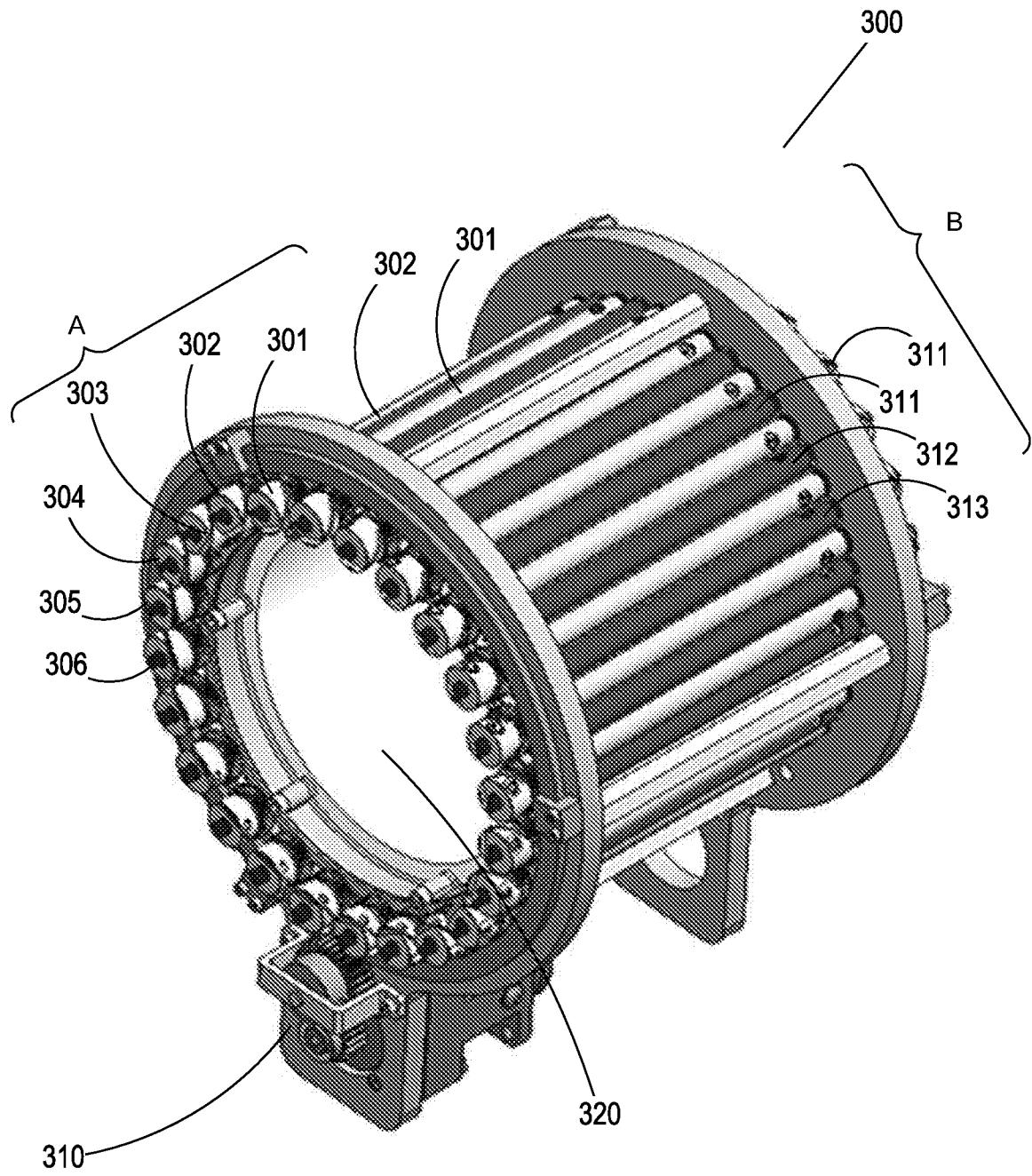

FIG. 3

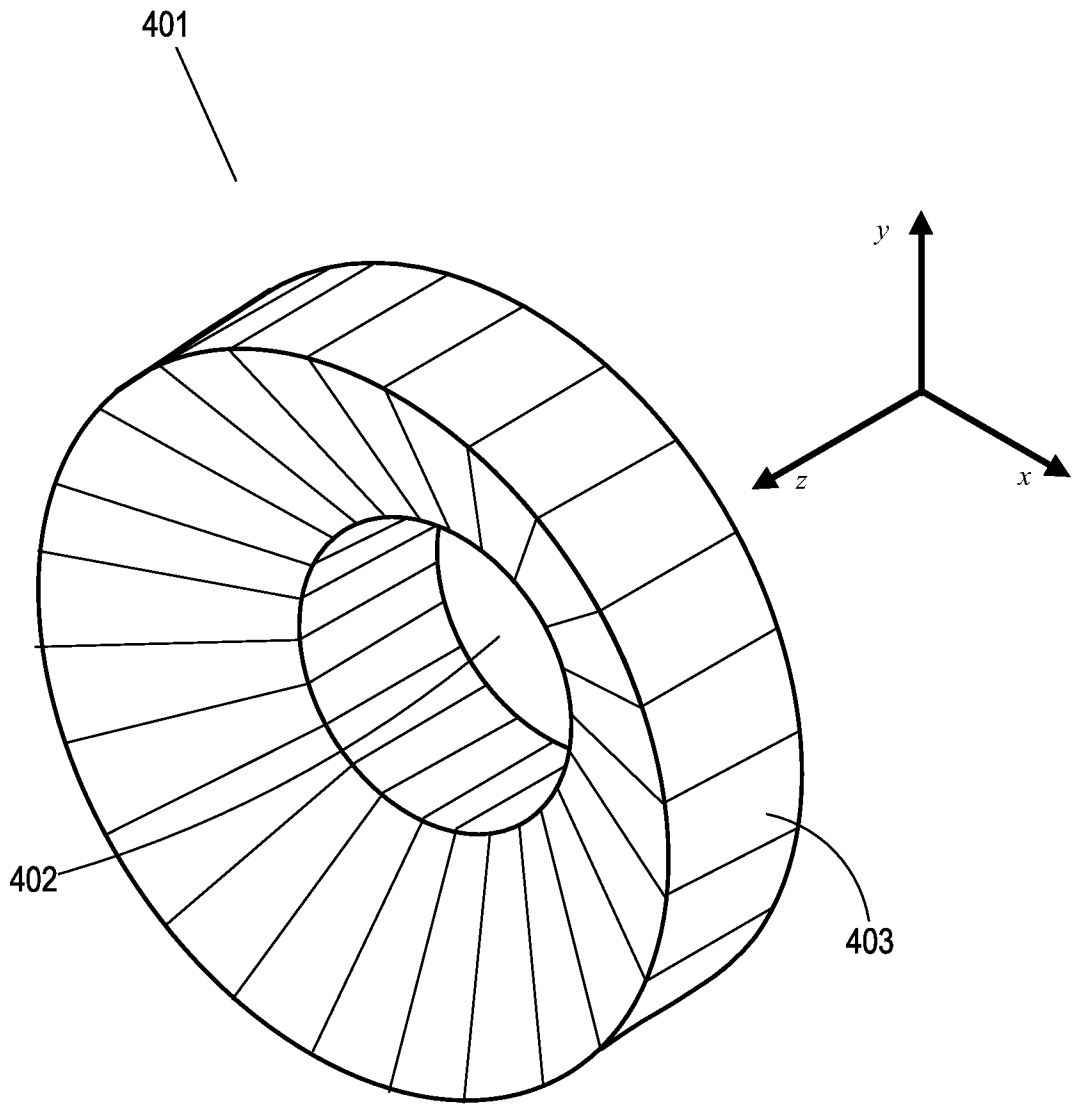
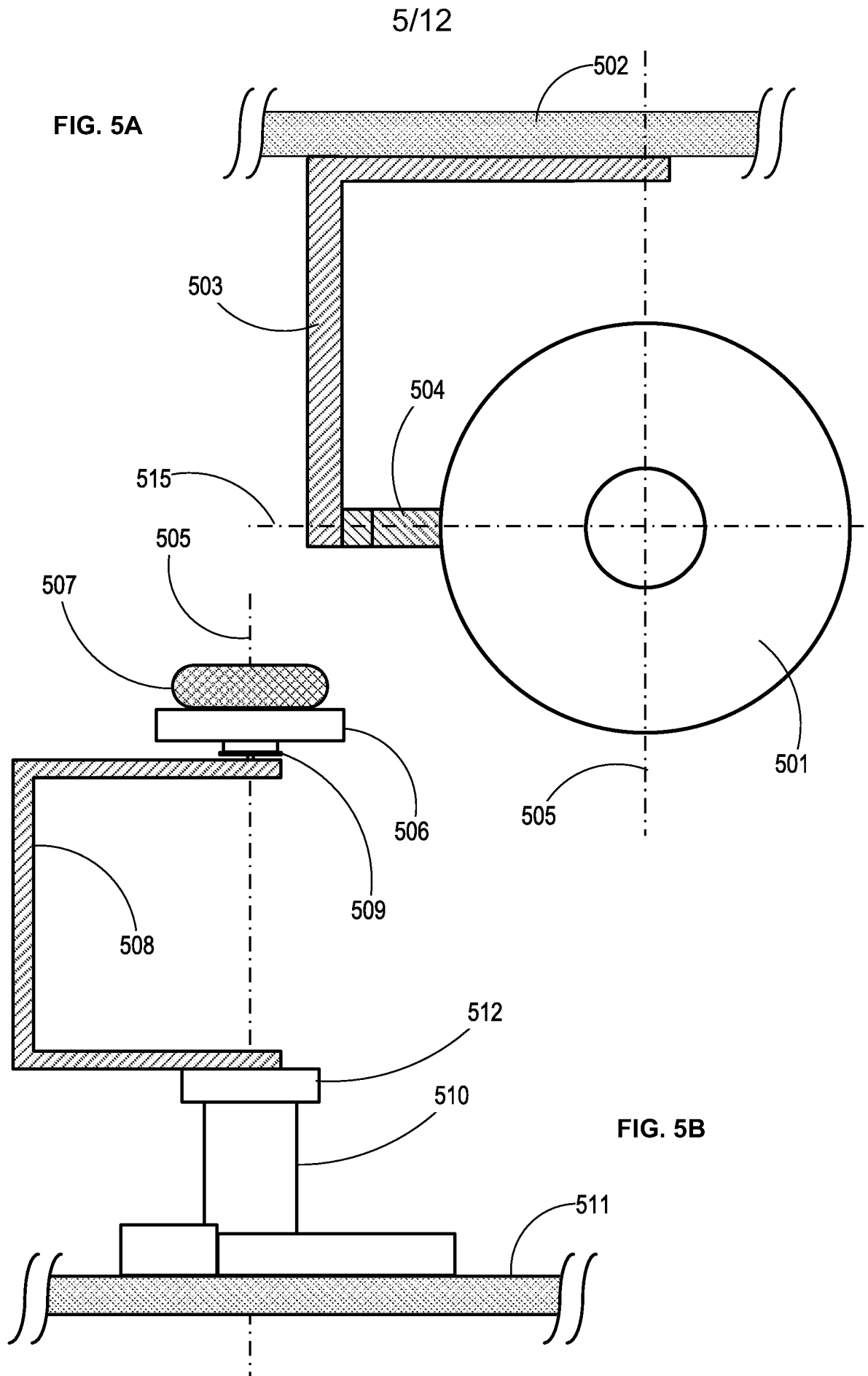

FIG. 4



6/12

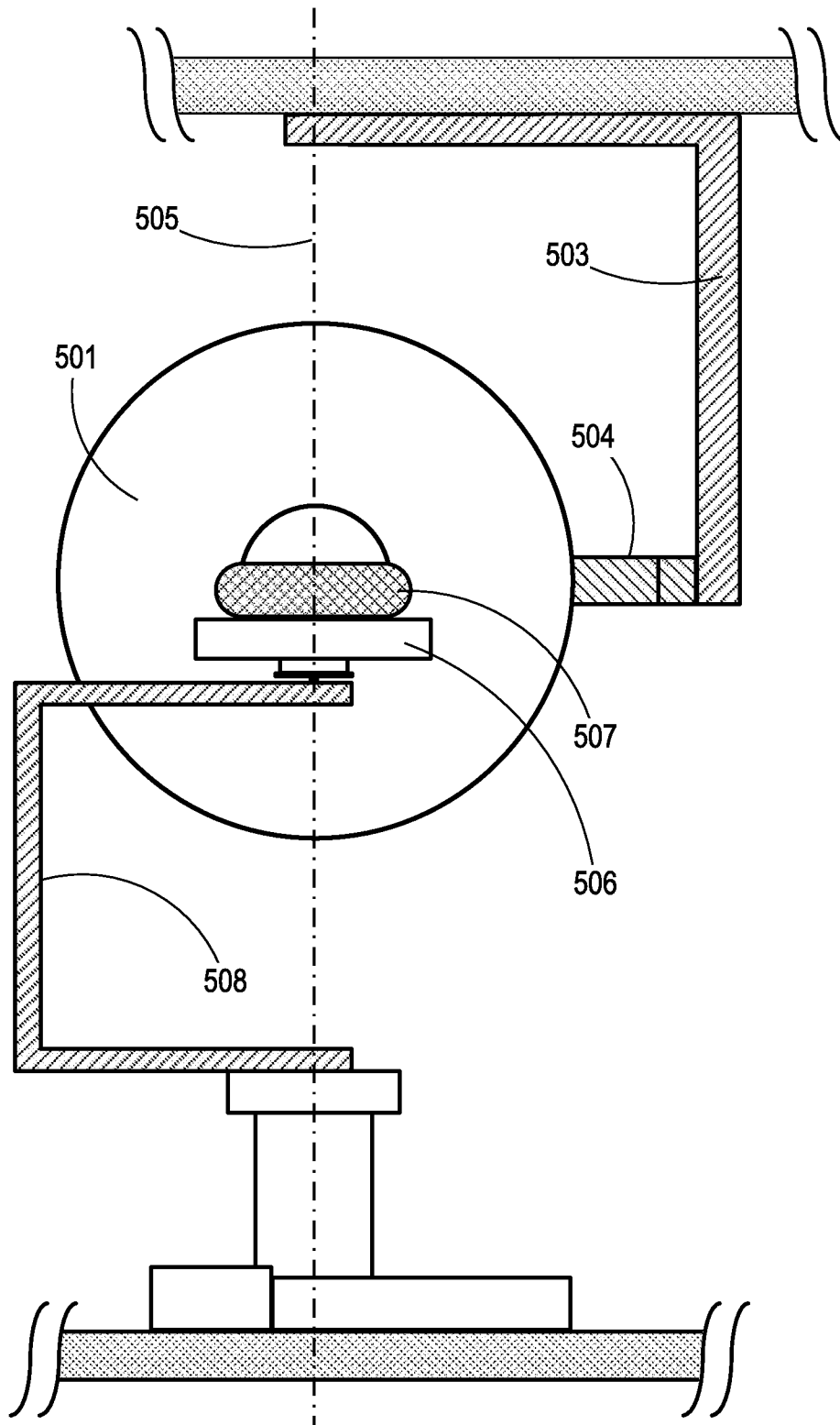

FIG. 6A

7/12

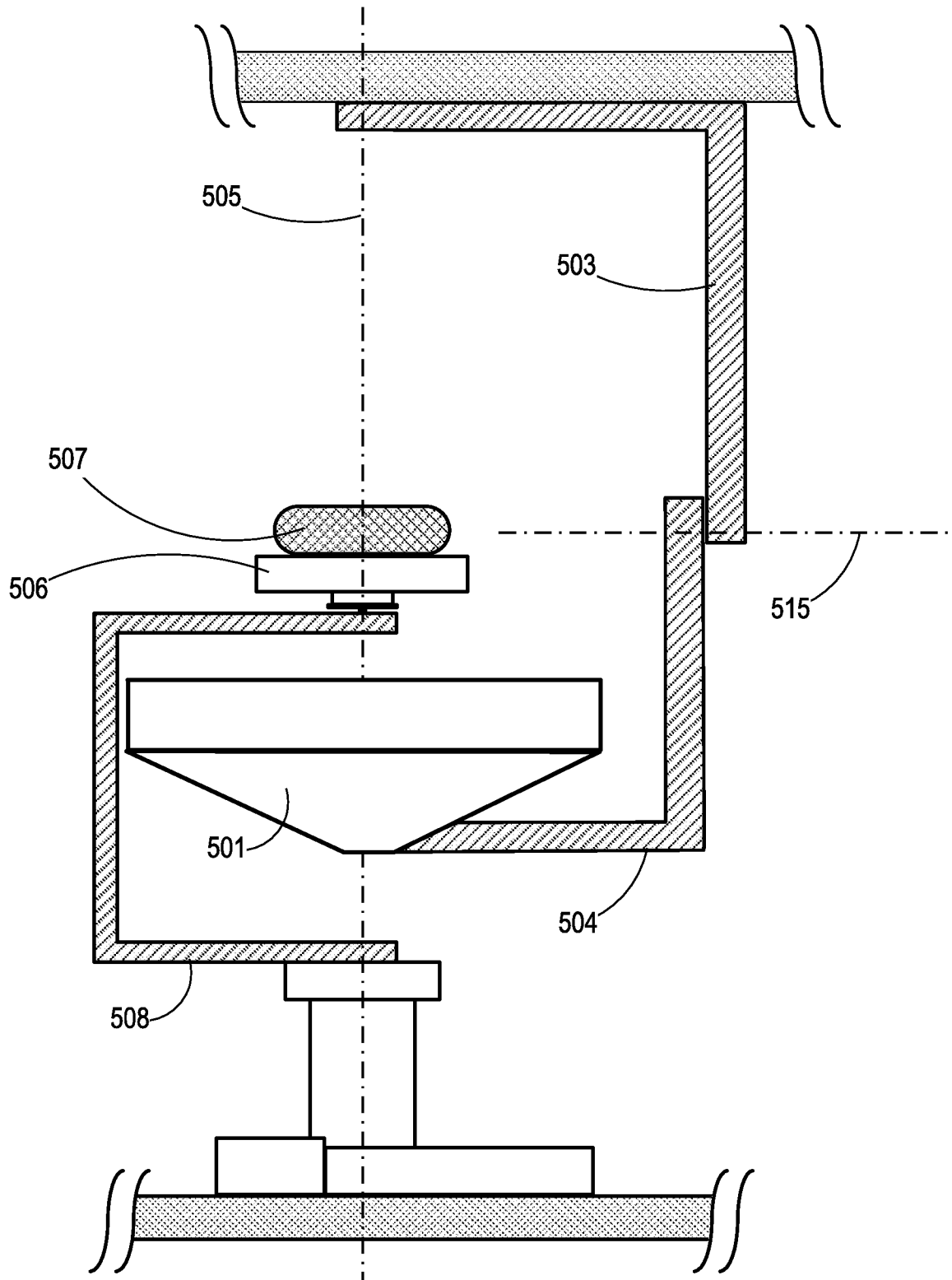

FIG. 6B

8/12

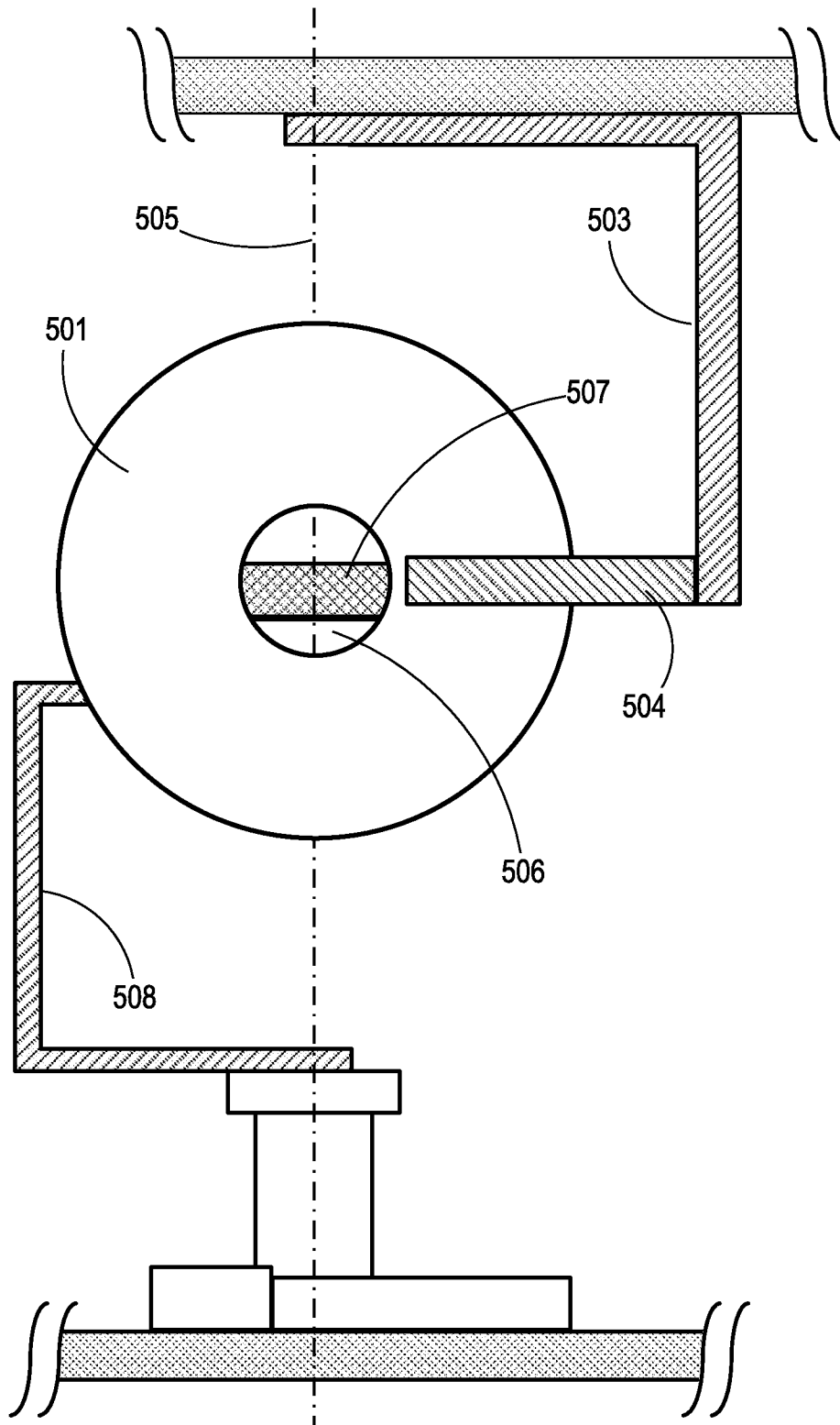

FIG. 6C

9/12

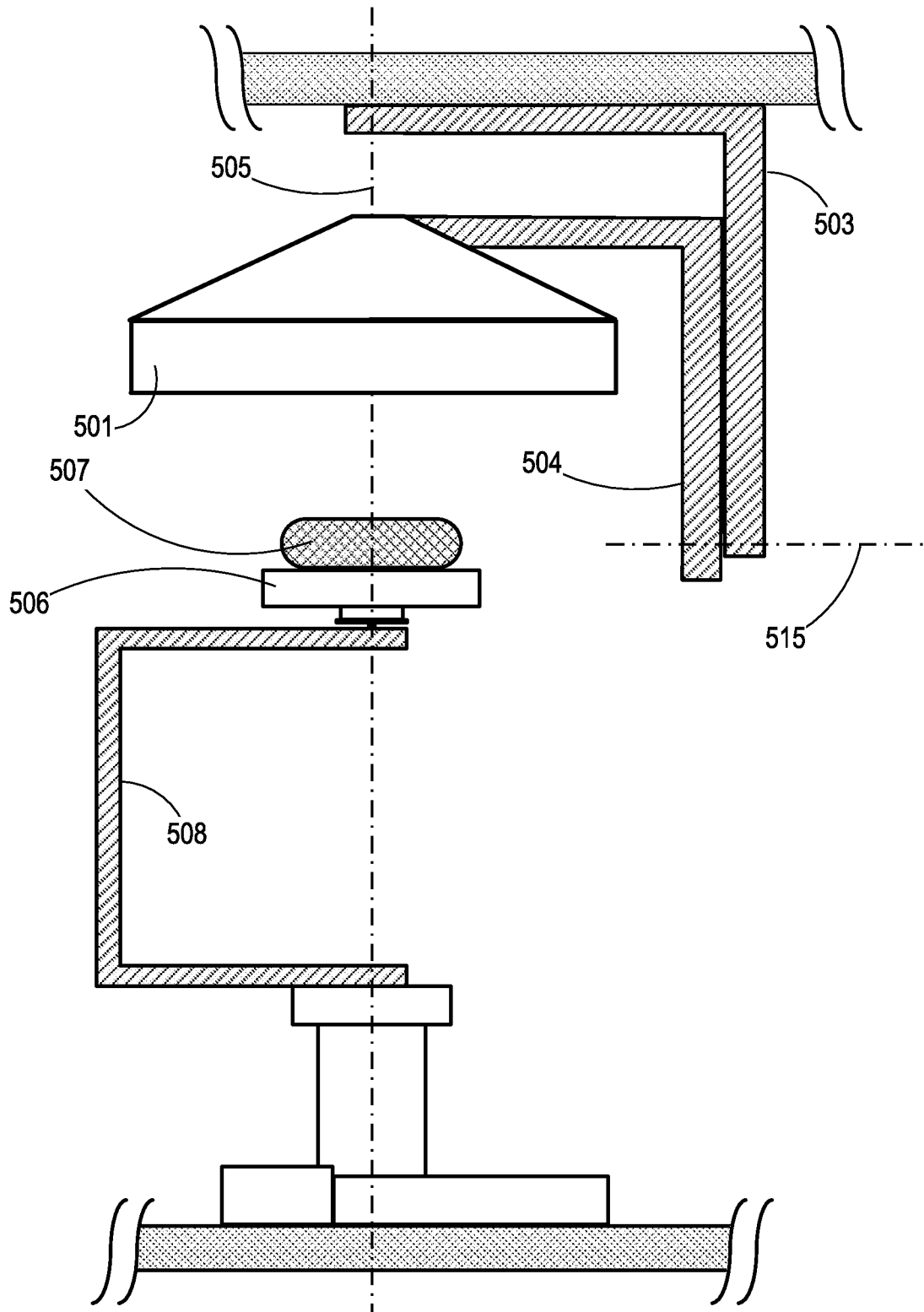

FIG. 6D

10/12

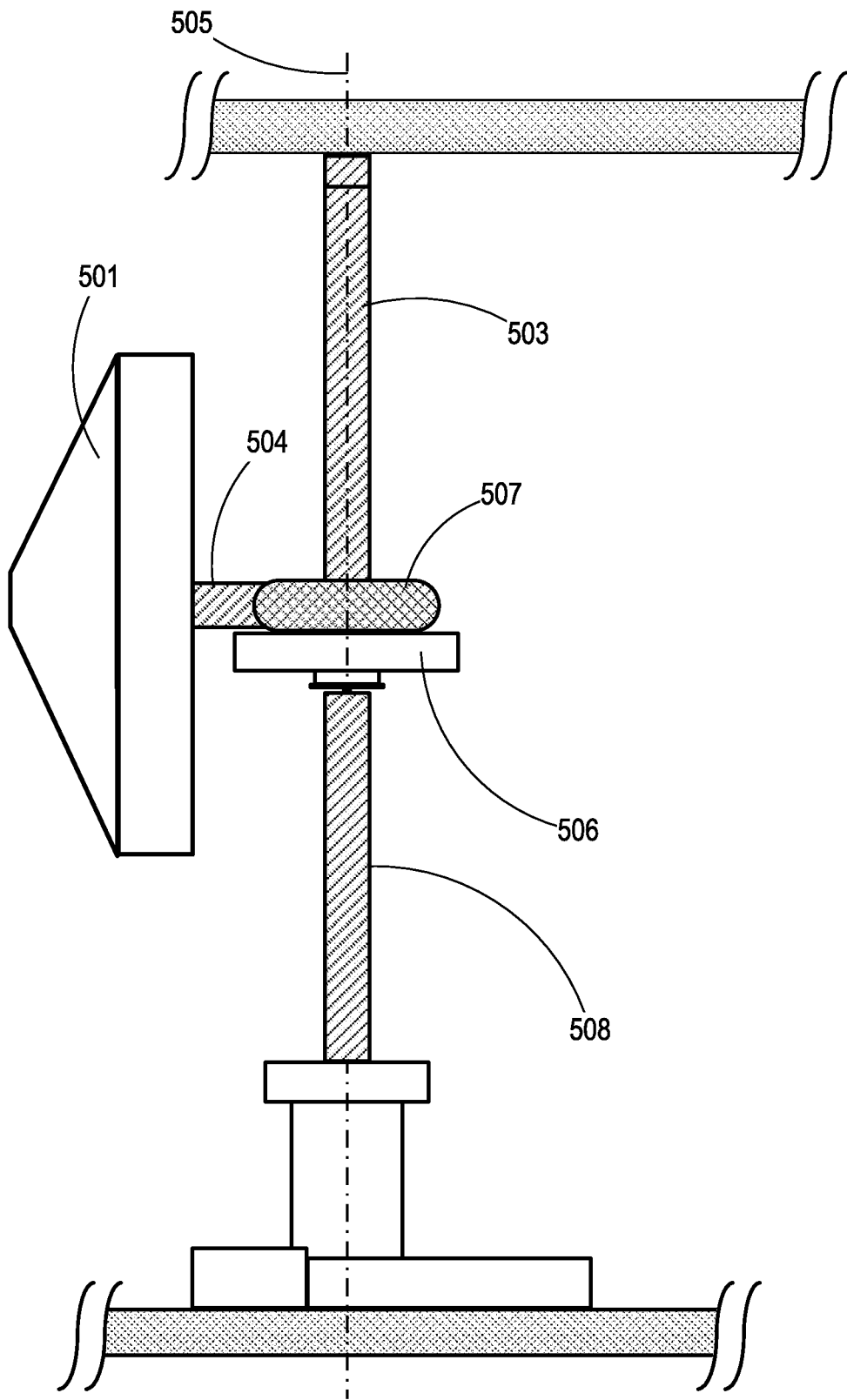

FIG. 6E

11/12

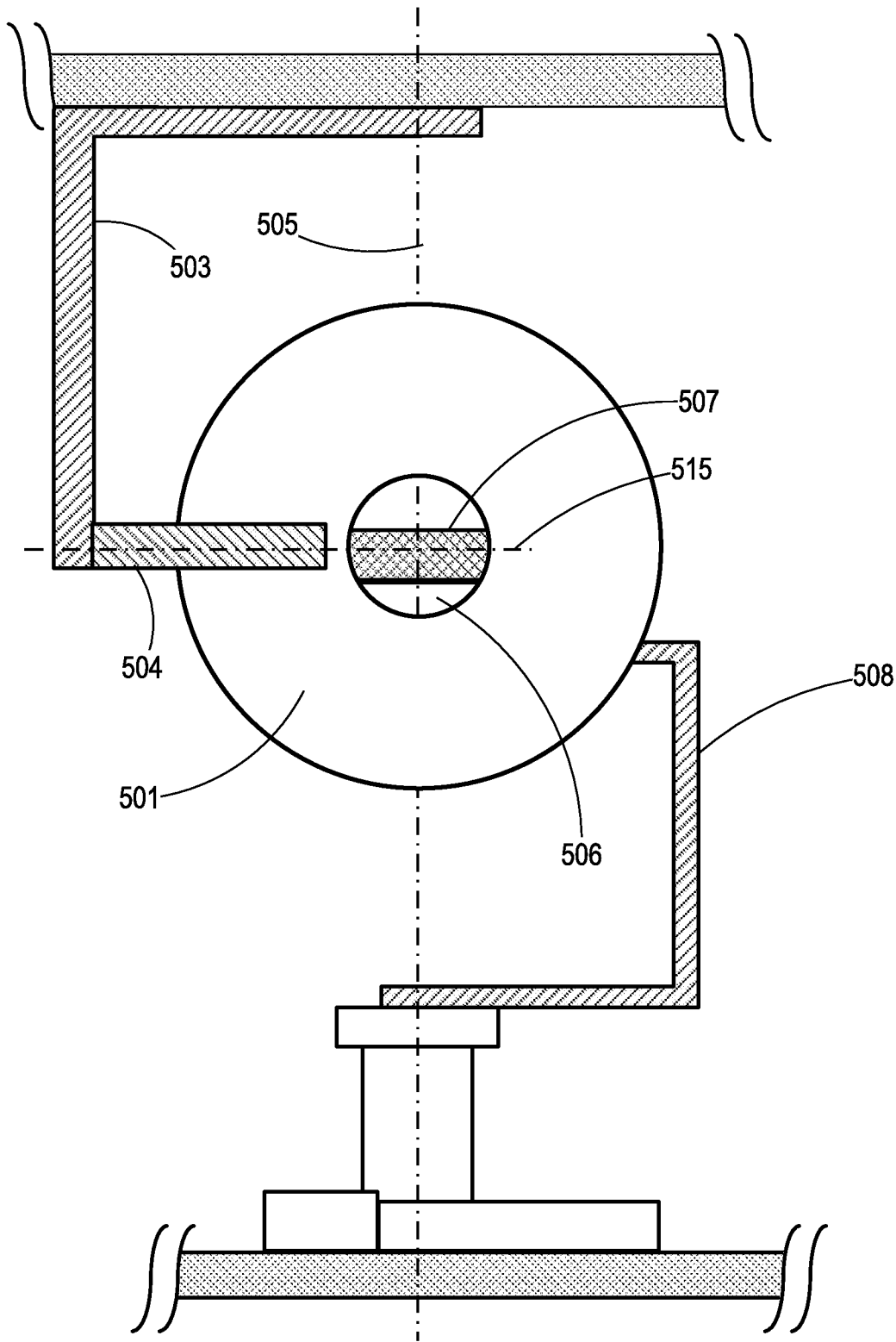

FIG. 6F

12/12

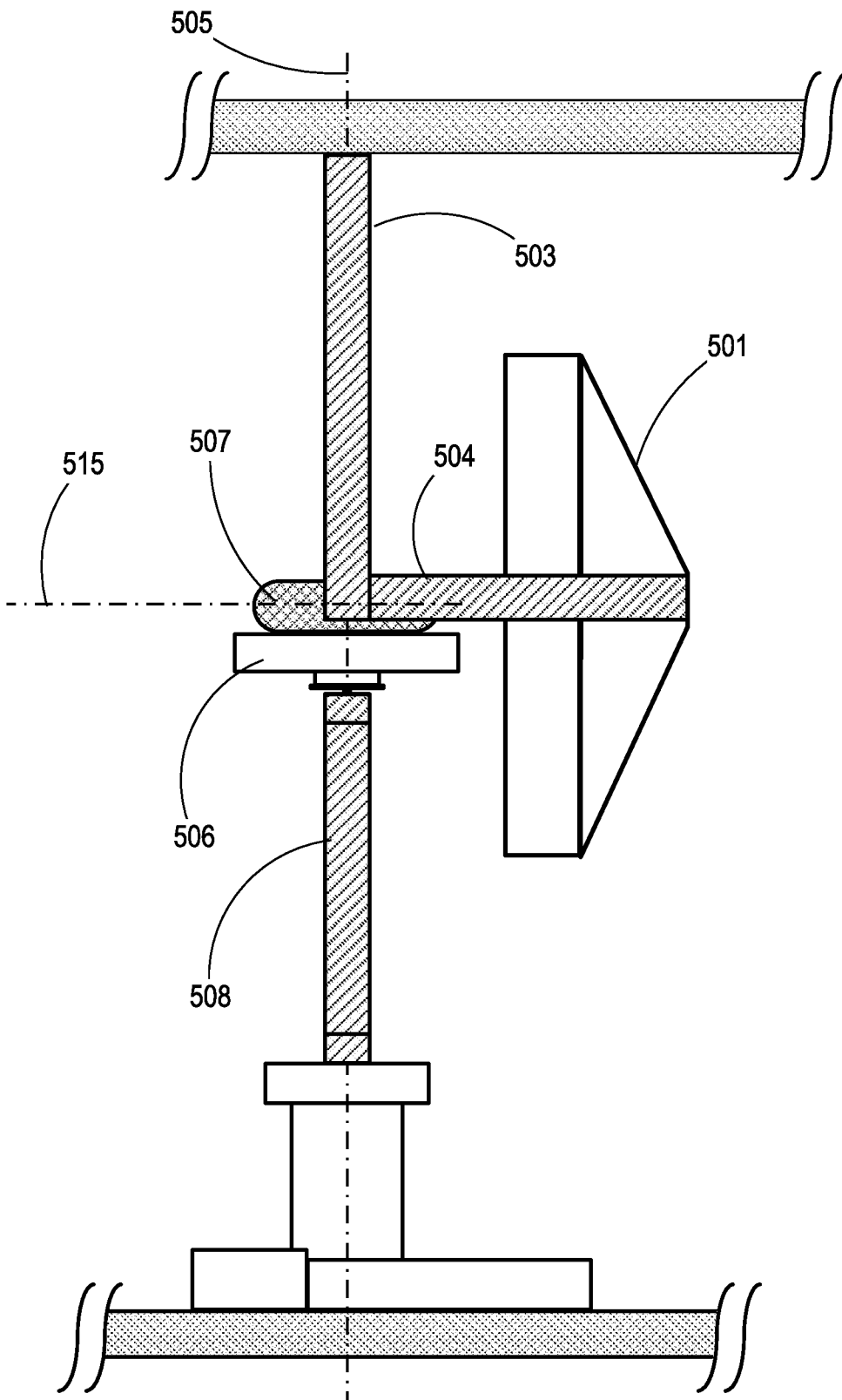

FIG. 6G

## INTERNATIONAL SEARCH REPORT

International application No.

PCT/US19/59096

## A. CLASSIFICATION OF SUBJECT MATTER

IPC - A61N 2/02, 2/06, 2/12; B82Y 5/00; G01R 33/383 (2020.01)

CPC - B01F 13/0818; G03F 7/70758; G01R 33/3873, 33/383; H01F 7/0284; H02N 11/008; A61N 2/006, 2/008, A61N 2/02, 2/06, 2/12; B82Y 5/00

According to International Patent Classification (IPC) or to both national classification and IPC

## B. FIELDS SEARCHED

Minimum documentation searched (classification system followed by classification symbols)

See Search History document

Documentation searched other than minimum documentation to the extent that such documents are included in the fields searched

See Search History document

Electronic data base consulted during the international search (name of data base and, where practicable, search terms used)

See Search History document

## C. DOCUMENTS CONSIDERED TO BE RELEVANT

Category*	Citation of document, with indication, where appropriate, of the relevant passages	Relevant to claim No.
Y	JOSHI, P et al. "Circular Halbach array for fast magnetic separation of hyaluronan-expressing tissue progenitor". Anal Chem. 2015 October 06; 87(19): 9908-9915. Publication [online]. Published 06 October 2015 [retrieved 03 January 2020]. Retrieved from Internet: <https://www.researchgate.net/publication/281778106_Circular_Halbach_Array_for_Fast_Magnetic_Separation_of_Hyaluronan-Expressing_Tissue_Progenitors><DOI:10.1021/acs.analchem.5b02431> ; figure 1; pages 3, 7-8; abstract	1-6
Y	WO 2018/187826 A1 (THE UNIVERSITY OF QUEENSLAND) 18 October 2018; figures 5C & 5D; paragraphs [0096]-[0097], [0101], [0164]	1-6
A	US 2015/0177343 A1 (GENERAL HOSPITAL CORPORATION) 25 June 2015; entire document	1-6
E, X	WO 2019/213362 A1 (BIONAUT LABS LTD) 07 November 2019; entire document	1-6
P, X	WO 2019/005293 A1 (BIONAUT LABS LTD) 03 January 2019; entire document	1-6

 Further documents are listed in the continuation of Box C. See patent family annex.

\* Special categories of cited documents:

"A" document defining the general state of the art which is not considered to be of particular relevance

"D" document cited by the applicant in the international application

"E" earlier application or patent but published on or after the international filing date

"L" document which may throw doubts on priority claim(s) or which is cited to establish the publication date of another citation or other special reason (as specified)

"O" document referring to an oral disclosure, use, exhibition or other means

"P" document published prior to the international filing date but later than the priority date claimed

"T" later document published after the international filing date or priority date and not in conflict with the application but cited to understand the principle or theory underlying the invention

"X" document of particular relevance; the claimed invention cannot be considered novel or cannot be considered to involve an inventive step when the document is taken alone

"Y" document of particular relevance; the claimed invention cannot be considered to involve an inventive step when the document is combined with one or more other such documents, such combination being obvious to a person skilled in the art

"&amp;" document member of the same patent family

Date of the actual completion of the international search

03 January 2020 (03.01.2020)

Date of mailing of the international search report

**18 MAR 2020**

Name and mailing address of the ISA/US

Mail Stop PCT, Attn: ISA/US, Commissioner for Patents  
P.O. Box 1450, Alexandria, Virginia 22313-1450  
Facsimile No. 571-273-8300

Authorized officer

Shane Thomas

Telephone No. PCT Helpdesk: 571-272-4300

INTERNATIONAL SEARCH REPORT

International application No.

PCT/US19/59096

Box No. II Observations where certain claims were found unsearchable (Continuation of item 2 of first sheet)

This international search report has not been established in respect of certain claims under Article 17(2)(a) for the following reasons:

- 1.  Claims Nos.:  
because they relate to subject matter not required to be searched by this Authority, namely:
  
- 2.  Claims Nos.:  
because they relate to parts of the international application that do not comply with the prescribed requirements to such an extent that no meaningful international search can be carried out, specifically:
  
- 3.  Claims Nos.:  
because they are dependent claims and are not drafted in accordance with the second and third sentences of Rule 6.4(a).

Box No. III Observations where unity of invention is lacking (Continuation of item 3 of first sheet)

This International Searching Authority found multiple inventions in this international application, as follows:

\*\*\*-Please see Supplemental Page-\*\*\*

- 1.  As all required additional search fees were timely paid by the applicant, this international search report covers all searchable claims.
- 2.  As all searchable claims could be searched without effort justifying additional fees, this Authority did not invite payment of additional fees.
- 3.  As only some of the required additional search fees were timely paid by the applicant, this international search report covers only those claims for which fees were paid, specifically claims Nos.:
- 4.  No required additional search fees were timely paid by the applicant. Consequently, this international search report is restricted to the invention first mentioned in the claims; it is covered by claims Nos.:  
1-6

Remark on Protest

- The additional search fees were accompanied by the applicant's protest and, where applicable, the payment of a protest fee.
- The additional search fees were accompanied by the applicant's protest but the applicable protest fee was not paid within the time limit specified in the invitation.
- No protest accompanied the payment of additional search fees.

INTERNATIONAL SEARCH REPORT

International application No.

PCT/US19/59096

-\*\*\*-Continued from Box No. III Observations where unity of invention is lacking-\*\*\*-

This application contains the following inventions or groups of inventions which are not so linked as to form a single general inventive concept under PCT Rule 13.1. In order for all inventions to be examined, the appropriate additional examination fee must be paid.

Group I: Claims 1-6 are directed toward a system for creating and controlling a magnetic field to manipulate a device with a magnetic component in a specimen, the system comprising: a cylindrical or similar organization of rod or rod like magnets enclosing a hollow space for the specimen; a first array of magnets; and a second array of magnets; and rotate all the magnets of the first array; and rotate all the magnets of the second array.

Group II: Claims 7-15 are directed toward a system for creating and controlling a magnetic field to manipulate a device with a magnetic component in a specimen under investigation, the system comprising: a stage for holding the specimen; support and orienting apparatus for the magnet, to which the magnet is attached; support and orienting apparatus for the stage, to which the stage is attached.

The inventions listed as Groups I & II do not relate to a single general inventive concept under PCT Rule 13.1 because, under PCT Rule 13.2, they lack the same or corresponding special technical features for the following reasons:

The special technical features of Group I include at least a cylindrical or similar organization of rod or rod like magnets enclosing a hollow space for the specimen; wherein the plurality of magnets form a Halbach array which includes: a first array of magnets; and a second array of magnets; and rotate all the magnets of the first array; and rotate all the magnets of the second array, which are not present in Group II.

The special technical features of Group II include at least a stage for holding the specimen; support and orienting apparatus for the magnet, to which the magnet is attached; support and orienting apparatus for the stage, to which the stage is attached; wherein the system is operative to orient the magnet over a solid angle of  $4\pi$  steradians with respect to the stage, which are not present in Group I.

The common technical features shared by Groups I & II are a system for creating and controlling a magnetic field to manipulate a device with a magnetic component in a specimen, the system comprising: a magnet for creating the magnetic field; and at least one positioning drive apparatus containing a motor.

However, these common features are previously disclosed by US 2015/0374395 A1 to Pulse Therapeutics Inc (Pulse Therapeutics) discloses a system for creating and controlling a magnetic field to manipulate a device with a magnetic component in a specimen (a system for creating and controlling a magnetic field to rotate magnetic particles (device) in blood (specimen); paragraphs [0027] & [0130]), the system comprising: a magnet for creating the magnetic field (a magnet 102 for creating the magnetic field; figures 1A & 1B; paragraphs [0027] & [0130]); and at least one positioning drive apparatus containing a motor (a drive motor 120 for rotating the magnet; figures 1A & 1B; paragraphs [0028] & [0137]).

Since the common technical features are previously disclosed by the Pulse Therapeutics reference, these common features are not special and so Groups I & II lack unity.