



(12) **DEMANDE DE BREVET CANADIEN
CANADIAN PATENT APPLICATION**

(13) **A1**

(86) Date de dépôt PCT/PCT Filing Date: 2017/10/27
(87) Date publication PCT/PCT Publication Date: 2018/06/07
(85) Entrée phase nationale/National Entry: 2019/03/20
(86) N° demande PCT/PCT Application No.: EP 2017/077666
(87) N° publication PCT/PCT Publication No.: 2018/099663
(30) Priorité/Priority: 2016/11/29 (EP16201194.4)

(51) Cl.Int./Int.Cl. *A61M 15/06* (2006.01),
A24F 47/00 (2006.01)
(71) Demandeur/Applicant:
PHILIP MORRIS PRODUCTS S.A., CH
(72) Inventeurs/Inventors:
BESSANT, MICHEL, CH;
MAZUR, BEN, GB;
SAADE LATORRE, EVA, CH;
TABASSO, ALAIN, CH
(74) Agent: RIDOUT & MAYBEE LLP

(54) Titre : SYSTEME DE GENERATION D'AEROSOL A DEBIT DE POMPE REGLABLE
(54) Title: AEROSOL-GENERATING SYSTEM WITH ADJUSTABLE PUMP FLOW RATE

Fig. 1

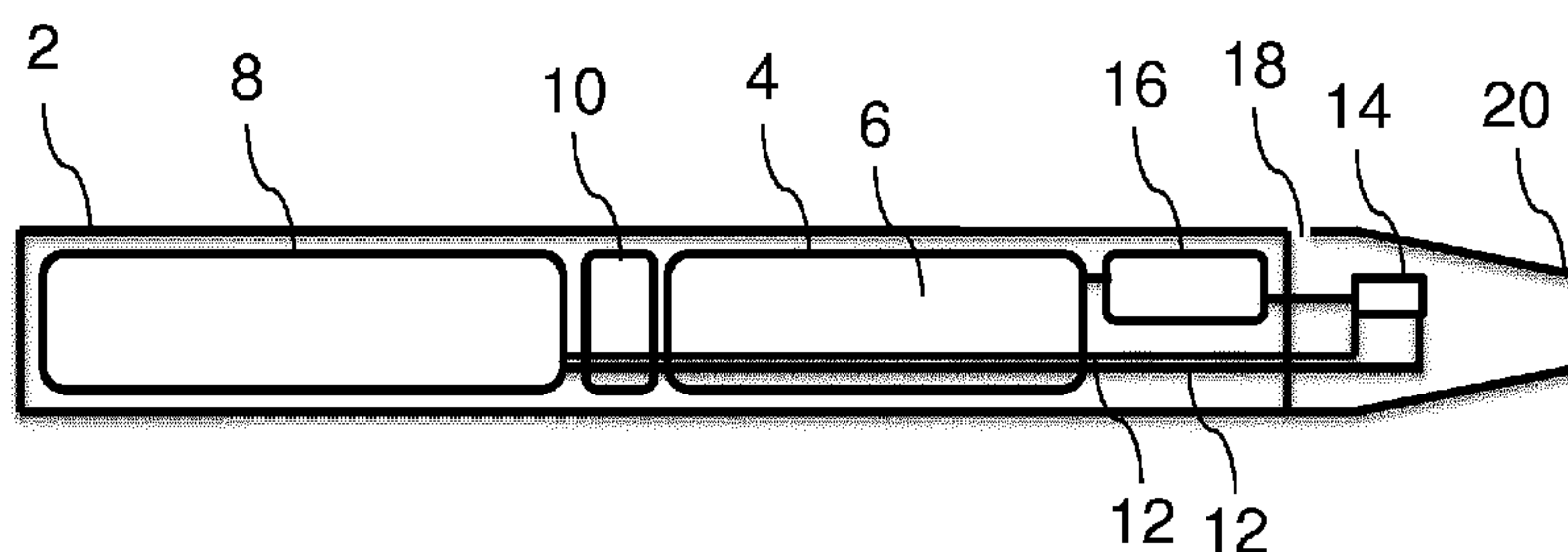

(57) **Abrégé/Abstract:**

The invention relates to a method for generating an aerosol in an aerosol-generating system. The method comprises the steps of storing liquid aerosol-forming substrate (6) in a liquid storage portion (4) and delivering via a pump (16) a liquid aerosol-forming substrate from the liquid storage portion to a vaporizer comprising a heating element (14). The method further comprises the step of providing a puff sensor in an airflow path of the aerosol-generating system for determining a puff intensity during a puff, and providing a controller (10) operatively connected to the puff sensor, the controller being configured to determine the puff intensity based on the puff sensor reading, and being configured to adjust the delivery flow rate of the pump and the electrical power supplied to the heating element in response to the determined puff intensity.

(12) INTERNATIONAL APPLICATION PUBLISHED UNDER THE PATENT COOPERATION TREATY (PCT)

(19) World Intellectual Property
Organization
International Bureau(43) International Publication Date
07 June 2018 (07.06.2018)(10) International Publication Number
WO 2018/099663 A1

- (51) **International Patent Classification:**
A61M 15/06 (2006.01) A24F 47/00 (2006.01)
- (21) **International Application Number:**
PCT/EP2017/077666
- (22) **International Filing Date:**
27 October 2017 (27.10.2017)
- (25) **Filing Language:** English
- (26) **Publication Language:** English
- (30) **Priority Data:**
16201194.4 29 November 2016 (29.11.2016) EP
- (71) **Applicant:** PHILIP MORRIS PRODUCTS S.A. [CH/CH]; Quai Jeanrenaud 3, 2000 Neuchâtel (CH).
- (72) **Inventors:** BESSANT, Michel; Rue Arnold-Guyot 5, 2000 Neuchâtel (CH). MAZUR, Ben; 44 Ralph Road, Ashley Down Bristol BS7 9QP (GB). SAADE LATORRE, Eva; Chemin de Bel-Air 47, 2000 Neuchâtel (CH). TABASSO, Alain; Route d'Echallens 27, 1417 Essertines-sur-Yverdon (CH).
- (74) **Agent:** GRITSCHNEDER, Sebastian et al.; Abitz & Partner Patentanwälte mbB, Arabellastr. 17, 81925 München (DE).
- (81) **Designated States** (unless otherwise indicated, for every kind of national protection available): AE, AG, AL, AM, AO, AT, AU, AZ, BA, BB, BG, BH, BN, BR, BW, BY, BZ, CA, CH, CL, CN, CO, CR, CU, CZ, DE, DJ, DK, DM, DO, DZ, EC, EE, EG, ES, FI, GB, GD, GE, GH, GM, GT, HN, HR, HU, ID, IL, IN, IR, IS, JO, JP, KE, KG, KH, KN, KP, KR, KW, KZ, LA, LC, LK, LR, LS, LU, LY, MA, MD, ME, MG, MK, MN, MW, MX, MY, MZ, NA, NG, NI, NO, NZ, OM, PA, PE, PG, PH, PL, PT, QA, RO, RS, RU, RW, SA, SC, SD, SE, SG, SK, SL, SM, ST, SV, SY, TH, TJ, TM, TN, TR, TT, TZ, UA, UG, US, UZ, VC, VN, ZA, ZM, ZW.
- (84) **Designated States** (unless otherwise indicated, for every kind of regional protection available): ARIPO (BW, GH, GM, KE, LR, LS, MW, MZ, NA, RW, SD, SL, ST, SZ, TZ, UG, ZM, ZW), Eurasian (AM, AZ, BY, KG, KZ, RU, TJ, TM), European (AL, AT, BE, BG, CH, CY, CZ, DE, DK, EE, ES, FI, FR, GB, GR, HR, HU, IE, IS, IT, LT, LU, LV, MC, MK, MT, NL, NO, PL, PT, RO, RS, SE, SI, SK, SM,

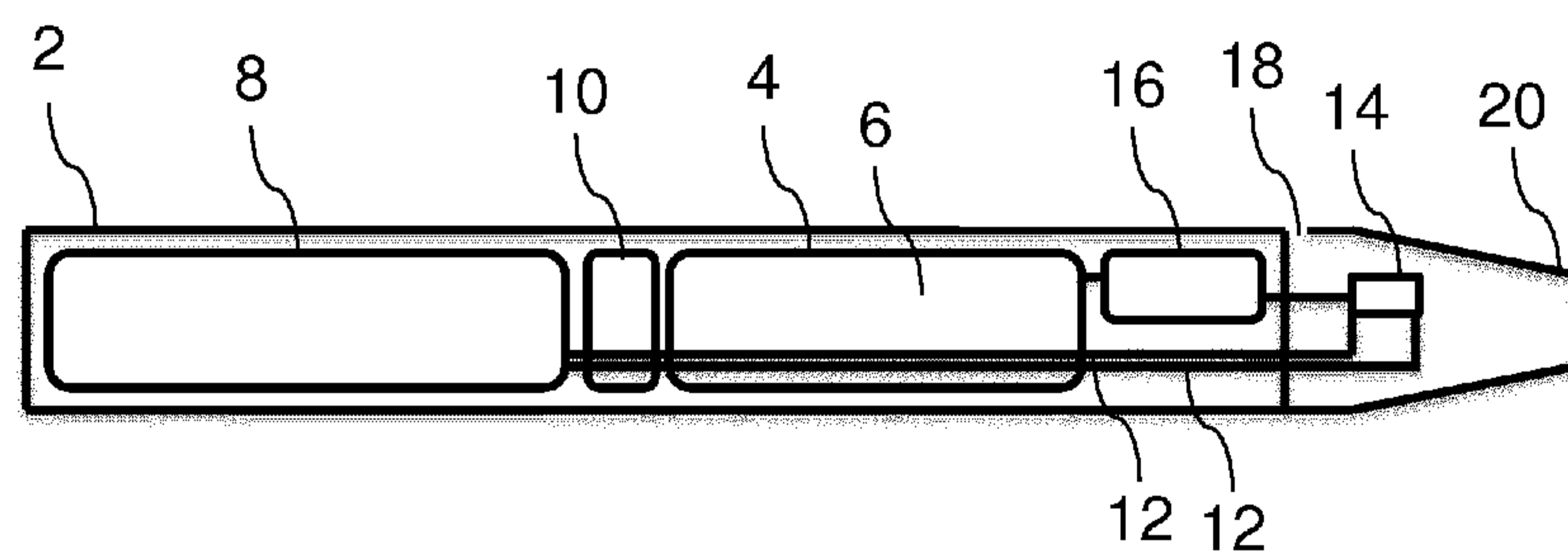
(54) **Title:** AEROSOL-GENERATING SYSTEM WITH ADJUSTABLE PUMP FLOW RATE**Fig. 1**

(57) **Abstract:** The invention relates to a method for generating an aerosol in an aerosol-generating system. The method comprises the steps of storing liquid aerosol-forming substrate (6) in a liquid storage portion (4) and delivering via a pump (16) a liquid aerosol-forming substrate from the liquid storage portion to a vaporizer comprising a heating element (14). The method further comprises the step of providing a puff sensor in an airflow path of the aerosol-generating system for determining a puff intensity during a puff, and providing a controller (10) operatively connected to the puff sensor, the controller being configured to determine the puff intensity based on the puff sensor reading, and being configured to adjust the delivery flow rate of the pump and the electrical power supplied to the heating element in response to the determined puff intensity.

[Continued on next page]

WO 2018/099663 A1 

TR), OAPI (BF, BJ, CF, CG, CI, CM, GA, GN, GQ, GW,
KM, ML, MR, NE, SN, TD, TG).

Declarations under Rule 4.17:

- *as to the identity of the inventor (Rule 4.17(i))*
- *as to applicant's entitlement to apply for and be granted a patent (Rule 4.17(ii))*

Published:

- *with international search report (Art. 21(3))*

-1-

AEROSOL-GENERATING SYSTEM WITH ADJUSTABLE PUMP FLOW RATE

The present invention relates to an aerosol-generating system comprising a pump, an atomizer and a puff sensor, wherein the delivery flow rate of the pump is adjusted in response to the determined puff intensity. The invention further relates to a corresponding method for generating an aerosol.

One type of aerosol-generating systems available on the market today comprises a vaporizer employing a so-called wick-and-coil arrangement. In these systems a part of a capillary wick extends into a liquid storage portion containing e-liquid to be volatilized. Another part of the wick is wound with a coil of heating wire. Upon application of an electric current, the heating wire evaporates the e-liquid comprised in the wick. In these systems, dose delivery may be difficult to control as it may depend on the puff frequency of the user and on the capillary properties of the wick.

In another type of aerosol-generating systems a reservoir, a micropump and a vaporizer are employed. During a puff a constant stream of e-liquid is actively pumped from the liquid storage portion to the vaporizer. In these systems, the flow rate of the micropump is kept constant such that an active control of the delivered dose is achieved. In this way a homogenous delivery of nicotine during an inhaling experience is provided.

It has been noted that the consumers' preferences for nicotine usage vary, as some users prefer a more intensive puffing regime than others. Therefore it would be desirable to provide an aerosol-generating system which may be configured to adjust e-liquid delivery per puff depending on the puff intensity of the user.

According to a first aspect of the invention the method for generating an aerosol in an aerosol-generating system, comprises the steps of storing liquid aerosol-forming substrate in a liquid storage portion, delivering via a pump the liquid aerosol-forming substrate from the liquid storage portion to an atomizer, and providing a sensor in an airflow path of the aerosol-generating system for determining a puff intensity during a puff. The delivery flow rate of the liquid aerosol-forming substrate to the atomizer is adjusted in response to the determined puff intensity.

The present invention offers the advantage that the flow rate of the pump, by which the liquid-aerosol-forming substrate is delivered to the atomizer, is adjusted to the intensity of the puff of the individual person using the aerosol-generating system. In this way, the aerosol composition experienced by the users may remain constant independent from the inhalation intensity.

It was surprisingly found by the inventors of the present method that typical puff profiles taken from a plurality of users share common characteristics. In particular it was

-2-

noted that independent from the overall intensity of a puff, the maximum intensity of a puff is reached after 0.3 to 0.6 seconds or 0.5 seconds after initiation of the puff. It was further noted that this maximum intensity can be used as a measure of the overall intensity of the puff. Thus, in the present invention the measured airflow rate or the measured pressure drop
5 in the airflow path after 0.3 to 0.6 seconds or 0.5 seconds of initiation of a puff may be used as a measure for the overall puff intensity. The delivery flow rate of the pump is adjusted according to the puff intensity. The pump may be configured as a micropump.

The sensor may be configured as an airflow sensor and may measure the airflow rate. The airflow rate is a parameter characterizing the amount of air that is drawn through
10 the airflow path of the aerosol-generating system per time by the user. Depending upon the detected airflow rate, the puff intensity may be determined. The higher the detected airflow rate is, the higher the determined puff intensity is. The airflow rate may – as described above – preferably be detected 0.3 to 0.6 seconds or 0.5 seconds after the initiation of the puff. The initiation of the puff may be detected by the airflow sensor when the airflow exceeds a
15 predetermined threshold. Initiation may also be detected upon a user activating a button.

The sensor may also be configured as a pressure sensor to measure the pressure of the air inside the aerosol-generating system which is drawn through the airflow path of the system by the user during a puff. The sensor may be configured to measure a pressure difference or pressure drop between the pressure of ambient air outside of the aerosol-
20 generating system and of the air which is drawn through the system by the user. The pressure of the air may be detected at an air inlet, preferably a semi-open inlet, a mouth end of the system, an aerosol formation chamber or any other passage or chamber within the aerosol-generating system, through which the air flows. When the user draws on the aerosol-generating system, a negative pressure or vacuum is created inside the system, wherein the
25 negative pressure may be detected by the pressure sensor. The term “negative pressure” is to be understood as a relative pressure with respect to the pressure of ambient air. In other words, when the user draws on the system, the air which is drawn through the system has a pressure which is lower than the pressure of ambient air outside of the system. The air pressure is – as described above – preferably be detected 0.3 to 0.6 seconds or 0.5 seconds
30 after the initiation of the puff. The initiation of the puff may be detected by the pressure sensor if the pressure difference exceeds a predetermined threshold. Initiation may also be detected upon a user activating a button. The higher the detected pressure difference is, i.e. the lower the pressure of the air which is drawn through the system is, the higher the determined puff intensity is.

-3-

The airflow rate or the pressure drop may also be continuously measured by the sensor and the puff intensity may be determined on basis of the highest airflow rate or highest pressure drop value in the course of a puff duration.

Depending upon the determined puff intensity, the delivery flow rate of the liquid aerosol-forming substrate from the pump towards the atomizer is adjusted. The flow rate of the liquid aerosol-forming substrate may be increased, when a high puff intensity is determined and decreased, when a low puff intensity is determined. The flow rate of liquid aerosol-forming substrate is a measure of the amount of liquid aerosol-forming substrate that is pumped from the liquid storage portion by the pump to the atomizer per time. In this regard, the atomizer may be operated for a predetermined time during the puff of a user, for example 0.5 seconds to 10 seconds or 1 second to 4 seconds or about 2 seconds. During this predetermined time, the amount of liquid aerosol-forming substrate which is pumped to the atomizer per time may be adjusted once the puff intensity is determined. Alternatively, the atomizer may be operated for as long as a puff lasts, i.e. as long as the user draws upon the aerosol-generating system. In this case, the amount of liquid aerosol-forming substrate which is pumped to the atomizer per time may be adjusted for the time during which the user draws upon the aerosol-generating system once the puff intensity is determined.

The atomizer is provided to atomize the liquid aerosol-forming substrate to form an aerosol, which can subsequently be inhaled by a user. The atomizer may comprise a heating element for vaporizing the liquid aerosol-forming substrate, in which case the atomizer will be denoted as a vaporizer. Generally, the atomizer may be configured as any device which is able to atomize the liquid aerosol-forming substrate. For example, the atomizer may comprise a nebulizer or an atomizer nozzle based on the Venturi effect to atomize the liquid aerosol-forming substrate. Thus, the atomization of the liquid aerosol-forming substrate may be realized by a non-thermally aerosolization technique. A mechanically vibrating vaporizer with vibrating elements, vibrating meshes, a piezo-driven nebulizer or surface acoustic wave aerosolization may be used.

The atomizer may be configured as a vaporizer and the heating regime of the heating element may be additionally adjusted. The heating element may be heated faster or to a higher temperature or with a higher electric power, when a high puff intensity is determined. Consequently, if a low puff intensity is determined, the heating of the heating element is conducted slower or to a lower temperature or with less electric power. By adjusting the heating regime of the vaporizer, the vaporization or aerosolization of the liquid aerosol-forming substrate may be adjusted to the puff intensity. Thereby, the user experiences a similar puff experience independent of the intensity, with which he draws upon the system. The flow rate of the liquid aerosol-forming substrate may be adjusted together with the

-4-

adjustment of the heating regime of the vaporizer, such that the puff experience of the user may be synergistically enhanced.

For determining the puff intensity and controlling the adjustment of the delivery flow rate of the liquid aerosol-forming substrate, a controller may be provided. The controller may also control the heating regime of the vaporizer. The controller may be operatively connected to the puff sensor. The controller may be operatively connected to the heating element. The controller may be configured to determine the puff intensity based on the puff sensor reading, that is, based on the detected parameter of the sensor. The controller may be configured to adjust the delivery flow rate of the pump and the electrical power supplied to the heating element in response to the determined puff intensity. For example, when the sensor detects a high airflow or a large pressure difference, the controller determines a high puff intensity and increases the flow rate of the liquid aerosol-forming substrate. Additionally, the controller may increase the heating temperature of the heating element of the vaporizer.

For determining the puff intensity, predetermined airflow values and/or pressure values may be stored in a look-up table. The controller may be configured to compare the parameter values which are detected by the sensor with the values which are stored in the look-up table to determine the puff intensity. The controller may compare the value, which is detected by the sensor after 0.3 to 0.6 seconds or around 0.5 second after the puff initiation with the values stored in the look-up table. The controller may also compare the highest value, which is detected by the sensor after 1 second or 0.7 seconds or 0.5 seconds after the initiation of the puff with the values stored in the look-up table. Alternatively, the controller may compare the highest value, which is measured by the sensor during a puff duration with the values stored in the look-up table.

The controller may comprise a microprocessor, which may be a programmable microprocessor. The controller may be part of electric circuitry, comprising further electronic components. The controller may be configured to regulate a supply of power to the atomizer. Power may be supplied to the atomizer continuously following activation of the system or may be supplied intermittently, such as on a puff-by-puff basis. The power may be supplied to the atomizer in the form of pulses of electrical current. The pump may be activated until the end of a puff is detected by the sensor.

The pump may be activated for the whole duration of the puff. The heating element of the vaporizer may stay activated for an additional predefined period of time, preferably 0.5 seconds after the pump is deactivated. Upon initialization of a puff, the heating element may be pre-heated to enhance the aerosol quality of the generated aerosol.

The electrical power supplied to the heating element may be adjusted by means of pulse width modulation. Hereto, a switch may be provided and used for switching between

-5-

supply and load on and off at a fast rate. During use of pulse width modulation, power loss in the switch is very low. When the switch is off there is practically no current, and when it is on and power is being transferred to the vaporizer, there is almost no voltage drop across the switch. Power loss is thus in both cases very low, increasing the efficiency of the vaporizer.

5 According to a second aspect of the invention, an aerosol-generating system is provided, the system comprising a housing with an air inlet or semi-open inlet and an air outlet, defining an airflow path there between. The system further comprises an atomizer for atomizing an aerosol-forming substrate and a pump configured for delivering liquid aerosol-forming substrate from a liquid storage portion to the atomizer. A puff sensor is provided
10 located in the airflow path, for determining a puff intensity during a puff. The delivery flow rate of the liquid aerosol-forming substrate to the atomizer is adjusted in response to the determined puff intensity.

The atomizer of the system may comprise a heating element for vaporizing the liquid aerosol-forming substrate, in which case the atomizer will be denoted as a vaporizer.

15 The system may further comprise a controller. The controller may be operatively connected to the puff sensor and to the heating element. The controller may be configured to determine the puff intensity based on the puff sensor reading. The controller may be configured to adjust the delivery flow rate of the pump and the electrical power supplied to the heating element in response to the determined puff intensity.

20 An adjusted amount of liquid aerosol-forming substrate may be pumped from the liquid storage portion to a deposition region of the heating element. By depositing the liquid aerosol-forming substrate to the heating element directly, the liquid aerosol-forming substrate can remain in its liquid state until it reaches the heating element. Consequently, few residues might be produced during liquid transport. Such a design can allow for production of
25 cartridges without atomizers. Due to the improved liquid transport, tubing segments and atomizers might not need to be disposed once the liquid storage portion is empty. By using a pump instead of a capillary wick or any other passive medium to draw liquid, only the actually required amount of liquid aerosol-forming substrate may be transported to the heating element. Liquid aerosol-forming substrate may only be pumped upon demand, for example a
30 request for a puff by a user.

Preferably, the aerosol-generating system further comprises a chamber into which the liquid aerosol-forming substrate is delivered, and wherein the heating element is arranged inside the chamber downstream of the outlet of the liquid storage portion.

35 As used herein, the terms 'upstream', 'downstream', 'proximal', 'distal', 'front' and 'rear', are used to describe the relative positions of components, or portions of components,

-6-

of the aerosol-generating system in relation to the direction in which a user draws on the aerosol-generating system during use thereof.

The aerosol-generating system may comprise a mouth end through which in use an aerosol exits the aerosol-generating system and is delivered to a user. The mouth end may also be referred to as the proximal end. In use, a user draws on the proximal or mouth end of the aerosol-generating system in order to inhale an aerosol generated by the aerosol-generating system. The aerosol-generating system comprises a distal end opposed to the proximal or mouth end. The proximal or mouth end of the aerosol-generating system may also be referred to as the downstream end and the distal end of the aerosol-generating system may also be referred to as the upstream end. Components, or portions of components, of the aerosol-generating system may be described as being upstream or downstream of one another based on their relative positions between the proximal, downstream or mouth end and the distal or upstream end of the aerosol-generating system.

Preferably, the aerosol-generating system further comprises a tubing segment through which the liquid aerosol-forming substrate is delivered from the liquid storage portion to the atomizer, and wherein the atomizer is arranged downstream of an open end of the tubing segment.

The tubing segment, also referred to as tube, may be a nozzle. The tubing segment may comprise any appropriate material, for example glass, metal, for example stainless steel, or plastics material, for example PEEK. For example, the tube may have a diameter of about 1 to 2 millimetres but other sizes are possible. Preferably, the tubing segment comprises a capillary tube. The cross-section of the capillary tube may be circular, ellipsoid, triangular, rectangular or any other suitable shape to convey liquid. At least a width dimension of the cross-sectional area of the capillary tube is preferably chosen to be sufficiently small such that on the one hand capillary forces are present. At the same time, the cross-sectional area of the capillary tube is preferably sufficiently large such that a suitable amount of liquid aerosol-forming substrate can be conveyed to the heating element. In general, the cross-sectional area of the capillary tube is preferably below 4 square millimetres, below 1 square millimetre, or below 0.5 square millimetres.

The atomizer may comprise a heating coil extending from the tubing segment in longitudinal direction. In some examples, the heating coil may be mounted transverse to the tubing segment. The heating coil may overlap with the open end of the tubing segment for up to 3 millimetres, preferably for up to 1 millimetre. In some examples, there may be a distance between the open end of the tubing segment and the heating coil. The length of the heating coil may be 2 millimetres to 9 millimetres, preferably 3 millimetres to 6 millimetres. The diameter of the heating coil may be chosen such that one end of the heating coil can be

-7-

mounted around the tubing segment. The diameter of the heating coil may be 1 millimetre to 5 millimetres, preferably 2 millimetres to 4 millimetres.

Preferably, the aerosol-generating system comprises a main unit and a cartridge, wherein the cartridge is removably coupled to the main unit, wherein the main unit comprises
5 a power supply, wherein the liquid storage portion is provided in the cartridge, and wherein the pump is provided in the main unit. Preferably, the main unit further comprises the atomizer. The main unit may comprise a tubing segment.

The aerosol-generating system advantageously comprises a power supply, typically a battery, within the main body of the housing. In some examples, the power supply may be
10 another form of charge storage device such as a capacitor. The power supply may require recharging and may have a capacity that allows for the storage of enough energy for one or more smoking experiences; for example, the power supply may have sufficient capacity to allow for the continuous generation of aerosol for a period of around six minutes or for a period that is a multiple of six minutes. In some examples, the power supply may have
15 sufficient capacity to allow for an estimated predetermined number of puffs or discrete activations of the heater assembly.

For allowing ambient air to enter the aerosol-generating system, a wall of the housing of the aerosol-generating system, preferably a wall opposite the atomizer, preferably a bottom wall, is provided with at least one semi-open inlet or air inlet. The semi-open inlet
20 allows air to enter the aerosol-generating system, but no air or liquid to leave the aerosol-generating system through the semi-open inlet. A semi-open inlet may for example be a semi-permeable membrane, permeable in one direction only for air, but is air- and liquid-tight in the opposite direction. A semi-open inlet may for example also be a one-way valve. Preferably, the semi-open inlets allow air to pass through the inlet only if specific conditions
25 are met, for example a minimum depression in the aerosol-generating system or a volume of air passing through the valve or membrane.

The liquid aerosol-forming substrate is a substrate capable of releasing volatile compounds that can form an aerosol. The volatile compounds may be released by heating the liquid aerosol-forming substrate. The liquid aerosol-forming substrate may comprise
30 plant-based material. The liquid aerosol-forming substrate may comprise tobacco. The liquid aerosol-forming substrate may comprise a tobacco-containing material containing volatile tobacco flavour compounds, which are released from the liquid aerosol-forming substrate upon heating. The liquid aerosol-forming substrate may alternatively comprise a non-tobacco-containing material. The liquid aerosol-forming substrate may comprise
35 homogenized plant-based material. The liquid aerosol-forming substrate may comprise homogenized tobacco material. The liquid aerosol-forming substrate may comprise at least

-8-

one aerosol-former. The liquid aerosol-forming substrate may comprise other additives and ingredients, such as flavourants.

The aerosol-generating system may be an electrically operated aerosol-generating system. Preferably, the aerosol-generating system is portable. The aerosol-generating
5 system may have a size comparable to a conventional cigar or cigarette. The aerosol-generating system may have a total length between approximately 30 millimetres and approximately 150 millimetres. The aerosol-generating system may have an external diameter between approximately 5 millimetres and approximately 30 millimetres.

The cartridge may be a disposable article to be replaced with a new cartridge once
10 the liquid storage portion of the cartridge is empty or below a minimum volume threshold. Preferably, the cartridge is pre-loaded with liquid aerosol-forming substrate. The cartridge may be refillable.

The aerosol-generating system may be in a preheat mode when the aerosol-generating system has been powered on. The electric circuitry preferably heats the heating
15 element constantly until the heating element reaches a predetermined operating temperature. The operating temperature may be 250 °C. The duration of the preheat mode may be controlled by the preheat duration parameter. Preferably, the preheat duration parameter is set to a value between 3 and 4 seconds. Under normal conditions, the aerosol-generating system may reach its operating temperature within the preheat duration. Once the
20 operating temperature is reached, the pump may be activated for at least one pump cycle to transport an adjusted amount of liquid aerosol-forming substrate through the pump to make the aerosol-generating system ready to use.

The aerosol-generating system may then enter the temperature hold mode until the electric circuitry detects a puff or until a hold timeout duration is reached as defined by the
25 value of the hold timeout duration parameter.

In temperature hold mode, a sequence of heating pulses may be sent to the heating element which can have the effect of maintaining a lower preheat temperature below the operating temperature until the hold timeout is reached. The lower preheat temperature may be 150 °C.

30 Once a puff has been detected and the heating element has reached the operating temperature, the controller may activate the pump and set an adjusted flow rate for delivering liquid aerosol-forming substrate to the deposition region of the heating element for the duration of the puff, wherein the flow rate depends upon the puff intensity.

Once the puff stops, the aerosol-generating system may return to the temperature
35 hold mode. If no input is detected during the temperature hold duration, the device may automatically cool down and wait for input.

The invention will be further described, by way of example only, with reference to the accompanying drawings in which:

Fig. 1 shows an aerosol-generating system in accordance with the present invention;

5 Fig. 2 shows experimental measurements of the relative pressure within an aerosol-generating system during a puff;

Fig. 1 shows an aerosol-generating system comprising a main body with a housing 2. Within the housing 2, a liquid storage portion 4 is provided. The liquid storage portion 4 holds liquid aerosol-forming substrate 6. The liquid storage portion 4 is not part of the main body and provided as a cartridge which can be disposed when the liquid aerosol-forming substrate 6 in the liquid storage portion 4 is depleted. After disposal of the liquid storage portion 4, a new liquid storage portion 4 is inserted into the housing 2.

The main body of the aerosol-generating system comprises a battery 8, which is connected to a controller 10. The controller 10 is configured to control the flow of electric current from the battery 8 via conductors 12 to a heating element 14 of a vaporizer. The controller 10 is further connected to a pump 16, which is provided to pump liquid aerosol-forming substrate 6 from the liquid storage portion 4 to the heating element 14 of the vaporizer. The pump 16 is configured as a micropump inside the main body of the aerosol-generating system.

20 The aerosol-generating system further comprises a pressure or airflow sensor, which is arranged in an airflow path near an air inlet 18. The sensor detects the airflow or pressure of the air within the airflow path, which is drawn by a user towards a mouth end 20 of the aerosol-generating system. In this regard, the sensor detects an airflow rate or pressure drop in the airflow path and the controller 10 determines the puff intensity based upon the sensor reading after 0.5 seconds after the puff initiation. The airflow rate denotes the amount of air per unit of time that flows through the airflow path.

The controller 10 is configured to adjust the delivery flow rate of liquid aerosol-forming substrate 6 from the liquid storage portion 4 to the heating element 14 of the vaporizer. The controller 10 increases the delivery flow rate if a high puff intensity is determined and decreases the delivery flow rate if a low puff intensity is determined. A high puff intensity is determined by the controller 10 when the sensor detects a high airflow rate or a high pressure drop.

In a further embodiment, the controller 10 is further configured to control the heating temperature of the heating element 14 of the vaporizer. The controller 10 increases the heating temperature if a high puff intensity is determined and decreases the heating temperature if a low puff intensity is determined.

-10-

After a puff initiation is detected by the sensor or a button, which the user presses, the controller controls the pump 16 to pump the liquid aerosol-forming substrate 6 from the liquid storage portion 4 to the heating element 14 of the vaporizer. The controller 10 adjusts the delivery flow rate based upon the determined puff intensity. The liquid aerosol-forming substrate 6 is vaporized by the vaporizer to form an aerosol. The aerosol is formed by mixing of the vaporized liquid aerosol-forming substrate 6 with ambient air which is drawn through the air inlet 18. The generated aerosol is subsequently inhaled by a user through the mouth end 20.

Fig. 2 shows a diagram of measurements of pressure drop values, measured in hectopascal (1 hPa = 100 Pa), over the time, measured in milliseconds, of a puff. The different measurements show that 0.3 to 0.6 seconds and especially around 0.5 seconds after the initiation of the puff, the pressure difference is the highest. After that, the pressure difference slowly decreases. Thus, the controller determines the puff intensity by evaluating the sensor measurement after around 0.5 seconds after the puff initiation.

15

-11-

CLAIMS

1. A method for generating an aerosol in an aerosol-generating system, comprising:

5 storing liquid aerosol-forming substrate in a liquid storage portion,
delivering via a pump a liquid aerosol-forming substrate from the liquid storage portion to an atomizer, wherein the atomizer is a vaporizer comprising a heating element for vaporizing the liquid aerosol-forming substrate,

10 providing a puff sensor in an airflow path of the aerosol-generating system for determining a puff intensity during a puff, and

providing a controller operatively connected to the puff sensor, the controller being configured to determine the puff intensity based on the puff sensor reading, and being configured to adjust the delivery flow rate of the pump and the electrical power supplied to the heating element in response to the determined puff intensity.

15

2. The method according to claim 1, wherein the step of determining the puff intensity is based on the puff sensor reading obtained after between 0.1 seconds and 0.9 seconds, preferably between 0.3 seconds and 0.7 seconds, more preferably between 0.3 seconds and 0.6 seconds, such as 0.5 seconds after initiation of the puff.

20

3. The method according to claim 2, further comprising the sub-step of
- detecting the initiation of the puff by the puff sensor, or
- detecting the initiation of the puff by the user activating a button.

25 4. The method according to any one of claims 1 to 3, further comprising the step of adjusting the electrical power supplied to the heating element in response to the delivery flow rate of the liquid aerosol-forming substrate.

30 5. The method according to any one of claims 1 to 4, wherein the controller is configured to determine the puff intensity and the corresponding delivery flow rate of the pump by comparing the puff sensor reading with values stored in a corresponding look-up table.

35 6. The method according to any one of claims 1 to 5, further comprising the sub-steps of activating the pump until the end of puff is detected.

-12-

7. The method according to any one of claims 1 to 6, further comprising the sub-steps of pre-heating the heating element upon initiation of a puff.

8. The method according to any one of claims 1 to 7, further comprising the sub-
5 steps of activating the heating element for the duration of the puff.

9. The method according to any one of claims 1 to 8, further comprising the step of activating the heating element for an additional predefined period of time, preferably 0.5 seconds after the pump has been deactivated.

10

10. An aerosol-generating system, the system comprising:
a housing with an air inlet and an air outlet, defining an airflow path there between,
an atomizer for atomizing an aerosol-forming substrate, wherein the atomizer is a
vaporizer comprising a heating element,

15 a pump configured for delivering liquid aerosol-forming substrate from a liquid storage portion to the atomizer,

a puff sensor located in the airflow path, for determining a puff intensity during a puff,
and

20 a controller operatively connected to the puff sensor and to the heating element, the controller being configured to determine the puff intensity based on the puff sensor reading and to adjust the delivery flow rate of the pump and the electrical power supplied to the heating element in response to the determined puff intensity.

11. The aerosol-generating system according to claim 10, wherein the puff sensor
25 is a pressure sensor or an airflow sensor.

Fig. 1

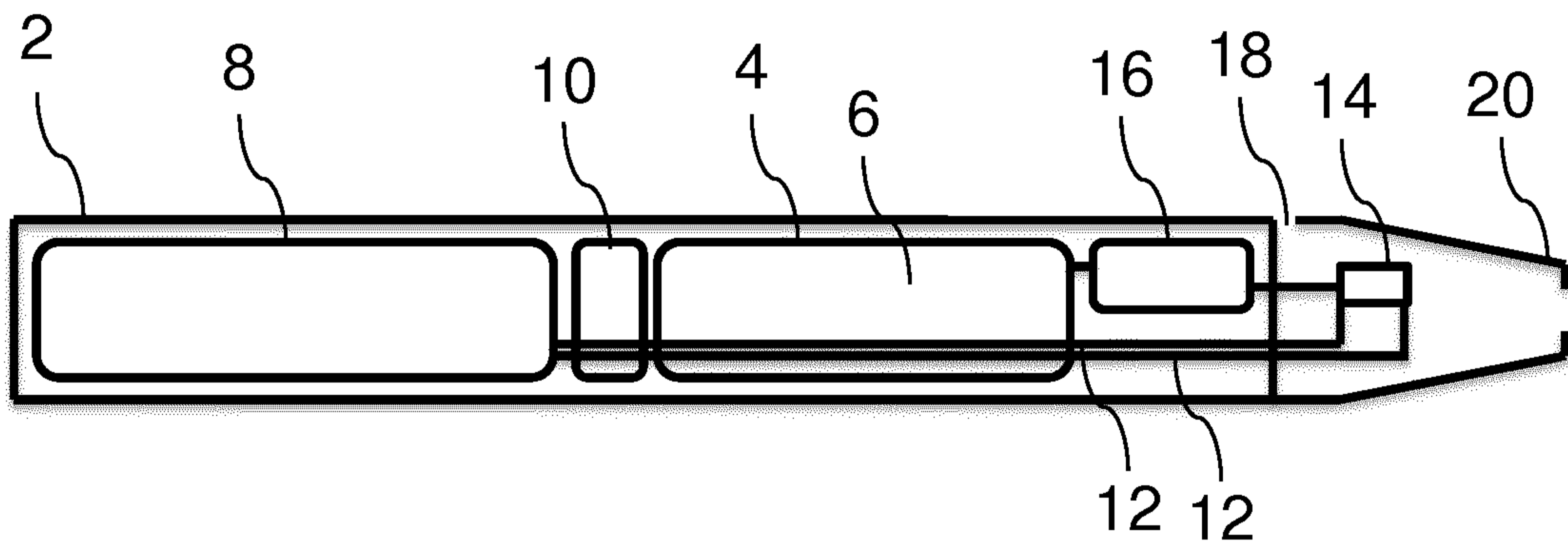

Fig. 2

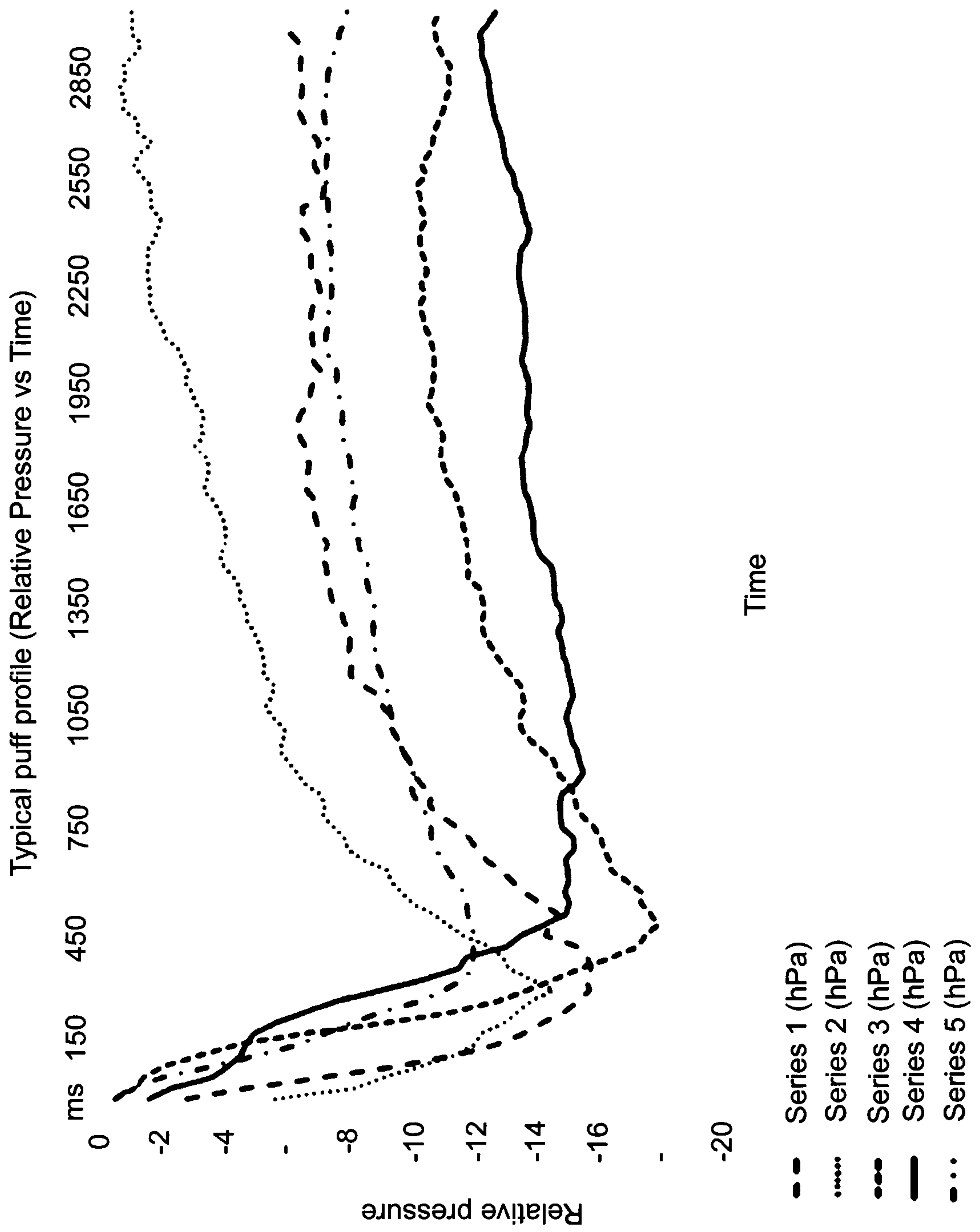

Fig. 1

