

(No Model.)

A. B. RONEY.  
ELECTRIC ARC LAMP.

No. 525,743.

Patented Sept. 11, 1894.

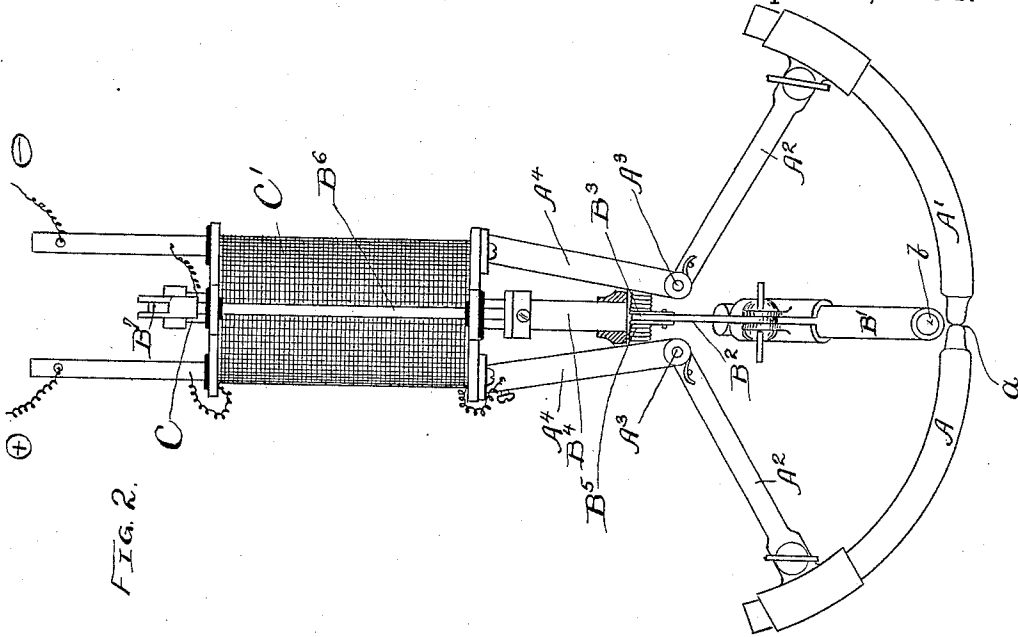

FIG. 2.

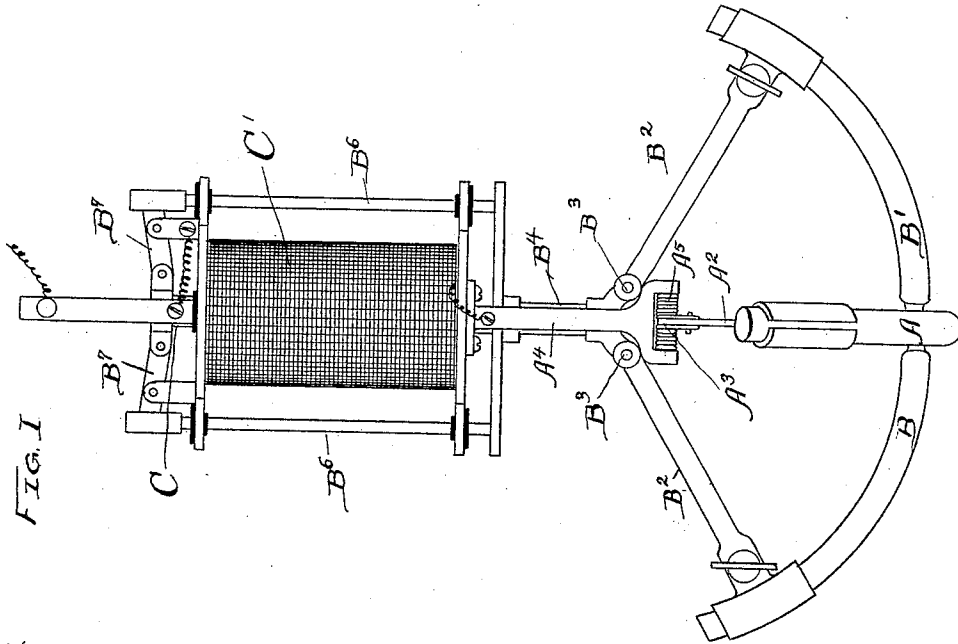

FIG. 1.

WITNESSES:

*Geo. C. Curtis*  
*A. W. Murray*

INVENTOR:  
ALEXANDER B. RONEY

BY *Munday, Curtis & Adcock.*

HIS ATTORNEY.

# UNITED STATES PATENT OFFICE.

ALEXANDER B. RONEY, OF CHICAGO, ILLINOIS, ASSIGNOR TO JOHN E. JACOBS, OF SAME PLACE.

## ELECTRIC-ARC LAMP.

SPECIFICATION forming part of Letters Patent No. 525,743, dated September 11, 1894.

Application filed March 7, 1894. Serial No. 502,676. (No model.)

*To all whom it may concern:*

Be it known that I, ALEXANDER B. RONEY, a citizen of the United States, residing in Chicago, in the county of Cook and State of Illinois, have invented a new and useful Improvement in Electric-Arc Lamps, of which the following is a specification.

This invention relates to an improvement in electric arc lamps, the purpose being to simplify and cheapen the mechanism and to produce a better light.

The nature of the invention will be understood by those skilled in the art from the following specification taken in connection with the accompanying drawings, which form a part of the same, and in which—

Figure 1 is a front elevation of the improved lamp; and Fig. 2 a side elevation, partly in section, of the same.

Like letters of reference denote like parts wherever used in the drawings.

In the present invention I make each of the carbon electrodes in two pieces, the pieces of each pair constituting a single electrode and being fed into contact with each other to supply the waste of carbon due to the burning. The arc is formed between the two electrodes opposite the juncture formed between the two pieces of each, so that the wasting occurs in each electrode at the meeting point of its two separate pieces of carbon. This arrangement dispenses with the necessity for any clutch carbon feeder, such as are so commonly used, produces a strong and brilliant light of a peculiar character, makes the lamp compact and obviates in great measure the shadows in a downward direction.

In the drawings A A' are the two pieces of carbon constituting the stationary electrode and B B' the two pieces constituting the movable electrode. The two pieces A A' are fed automatically into contact at the point *a*, and the two pieces B B' in like manner at the point *b*. The arc is formed between the points *a* and *b* and the carbon adjacent thereto. I prefer to construct the pieces A A' B B' of curvilinear form as shown in the drawings, and to suspend each piece in a pivoted holder as this greatly simplifies the automatic feed-

ing of the pieces together as the carbon consumes during the use of the lamp. A<sup>2</sup> A<sup>2</sup> are the holders for the pieces A A', and these holders are pivoted at A<sup>3</sup> to the stationary frame work of the lamp and preferably to the dependent standards A<sup>4</sup>. When so constructed the weight of the holders themselves and the carbon they contain will tend to keep the pieces A and A' constantly in contact at the junction point *a*; but I prefer to provide a spring A<sup>5</sup> to assist this tendency and to hold the carbon pieces more evenly and forcibly in contact. It is desirable that the pivots A<sup>3</sup> shall be brought as near a common center as possible in the construction of the lamp.

B<sup>2</sup> B<sup>2</sup> are similar pivotally suspended holders for the pieces B B', and they are pivoted at B<sup>3</sup> B<sup>3</sup> to the movable standard B<sup>4</sup>, and springs B<sup>5</sup> similar to the springs A<sup>5</sup> are provided for these holders. The movable standard B<sup>4</sup> is attached to the movable frame work B<sup>6</sup>, the upper end of which is attached by means of levers B<sup>7</sup> to the core C of the solenoid C'. The electric current is led into the lamp, passing through the movable frame work to the parts B B' of the movable pair of carbons, thence through the stationary pair of carbons, to the stationary frame work, thence through the solenoid and out to the line. A switch between the lamp and the line should of course be provided, but it is not shown in the drawings.

The operation of the lamp is as follows:— When the current is turned on, the solenoid being energized draws its core down which operates to lift the movable frame B<sup>6</sup>, the holders attached thereto and the carbon pieces B B' separating the latter from contact with the carbon pieces A A', and thus establishing between the carbons A A' and the carbons B B' an electric arc opposite the points *a b*, whereupon the lamp is burning. The solenoid now constantly regulates and maintains the arc so formed by permitting the movable carbons to approach the stationary ones as the current is weakened by the resistance caused by a too great lengthening of the arc on the one hand, and by separating the movable carbons

from the stationary ones when the arc becomes too short and the resistance too small, on the other hand.

I claim—

5 1. The electric arc lamp comprising in combination two pairs of carbons, each pair feeding to a common center, one of said pairs being mounted in a movable frame work, a lever for moving said frame work and electro  
10 magnetic means for forming and maintaining the electric arc between the two pairs of carbons, substantially as specified.

2. In an electric arc lamp, the combination  
15 of the solenoid C', the levers B<sup>7</sup> attached to the core of the solenoid, the movable frame work B<sup>6</sup> carrying the pivotally suspended

holders B<sup>2</sup>, said holders B<sup>2</sup>, the stationary frame work A<sup>4</sup>, and the holders A<sup>2</sup> pivotally connected thereto, substantially as specified.

3. In an electric arc lamp, the combination  
20 of the solenoid C', the levers B<sup>7</sup> attached to the core of the solenoid, the movable frame work B<sup>6</sup> carrying the pivotally suspended holders B<sup>2</sup>, said holders B<sup>2</sup>, the stationary  
25 frame work A<sup>4</sup>, and the holders A<sup>2</sup> pivotally connected thereto, said holders A<sup>2</sup> and B<sup>2</sup> being furnished with springs, substantially as specified.

ALEXANDER B. RONEY.

Witnesses:

H. M. MUNDAY,  
S. E. CURTIS.