



(22) Date de dépôt/Filing Date: 2004/06/25

(41) Mise à la disp. pub./Open to Public Insp.: 2005/12/25

(45) Date de délivrance/Issue Date: 2007/02/27

(51) Cl.Int./Int.Cl. *B60R 9/00* (2006.01),
B60R 11/06 (2006.01)

(72) Inventeur/Inventor:
GRAFTON, ROBERT D., US

(73) Propriétaire/Owner:
GRAFTON, ROBERT D., US

(74) Agent: BERESKIN & PARR

(54) Titre : COFFRE A TIROIRS COULISSANTS POUR VEHICULE

(54) Title: SLIDING TRAY TRUNK FOR A VEHICLE

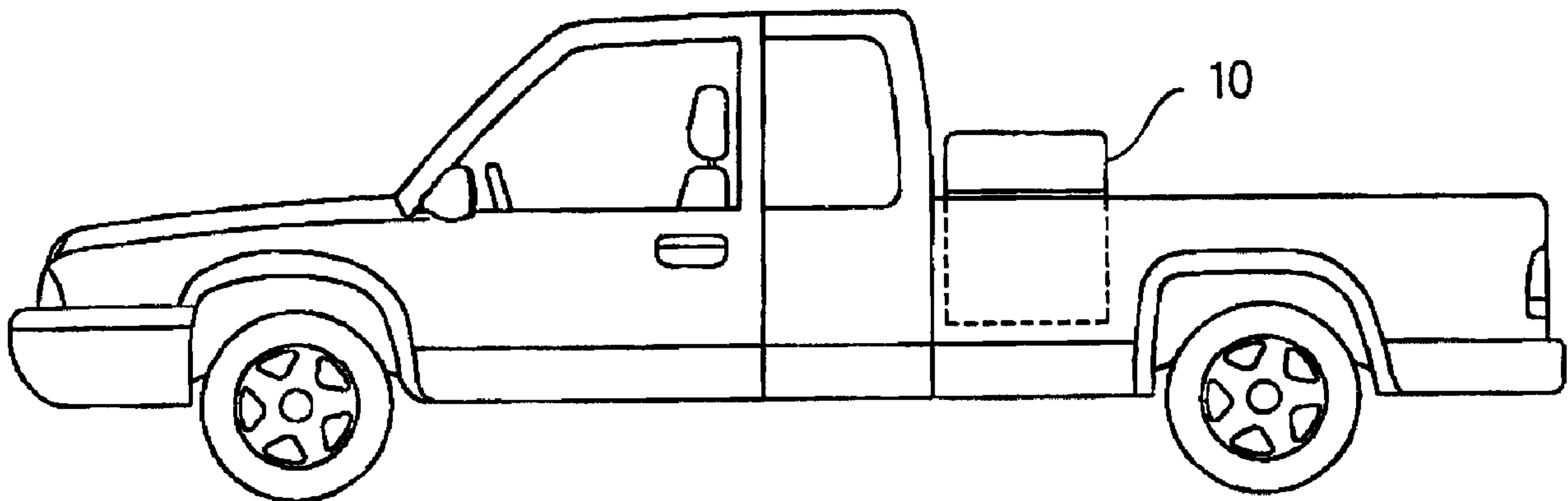

(57) Abrégé/Abstract:

A sliding tray trunk for a vehicle having a lower storage box, an upper storage box slidably attached on top of the storage box, a locking cover that secures the upper storage box over the lower storage box, and one or more stops to limit sliding of the upper storage box on the lower storage box to a predetermined distance is provided. The lower storage box has a substantially rectangular shape. The lower storage box has two rails on which the upper storage box can slide. A plurality of wheels are rotatably attached on each of the rails, and the upper storage box slides by rotation of the wheels.



ABSTRACT

A sliding tray trunk for a vehicle having a lower storage box, an upper storage box slidably attached on top of the storage box, a locking cover that secures the upper storage box over the lower storage box, and one or more stops to limit sliding of the upper storage box on the lower storage box to a predetermined distance is provided. The lower storage box has a substantially rectangular shape. The lower storage box has two rails on which the upper storage box can slide. A plurality of wheels are rotatably attached on each of the rails, and the upper storage box slides by rotation of the wheels.

15

20

25

SLIDING TRAY TRUNK FOR A VEHICLE**By****ROBERT D. GRAFTON**

5

BACKGROUND OF THE INVENTION

The present invention relates to a storage trunk for a truck. More particularly, the invention relates to a two-compartment storage trunk for a truck that provides enhanced accessibility to the inside of the trunk.

10

Pickup truck cross bed tool/storage boxes have been in use for many years in various shapes, sizes and materials. In general, all have a common design feature which allows the user to access the contents of the box from the top by standing at the side or climbing into the bed of the vehicle. Because of the design nature of these cross bed boxes, contents are often difficult to access because the user must reach over the higher sides of the cross bed box or climb into the rear of the vehicle to reach contents. Several prior art trunks for pickup trucks are explained below.

15

20

U.S. Patent 4,993,771 to Ingerson et al. discloses a trunk for pickup trucks having a horizontally slidable panel across the top of the trunk. The storage space of the trunk is not partitioned thus creating a disorganized mix of large and small items.

25

U.S. Patent 5,121,959 to King discloses a slide
mount for moving a trunk to the rear of the vehicle
within the bed of a pickup truck. In order to slide the
trunk to the rear, the storage area of the bed should be
5 completely cleared.

U.S. Patent 5,299,722 to Cheney discloses a trunk
having a rectangular box and a lower lid hinged on the
box. An upper lid is hinged on the lower lid. The space
between the lower lid and the upper lid may be used for
10 storing slim items.

U.S. Patent 5,439,150 to Trahms discloses a trunk
having a box covered with pivotable top parts to allow
access into the box. The user should reach through the
top parts to access contents in the box.

15 U.S. Patent 5,484,092 to Cheney discloses a trunk
having a first larger storage compartment and a second
smaller storage compartment that is positioned inside the
first compartment.

20

SUMMARY OF THE INVENTION

The present invention contrives to provide a trunk
for pickup truck that implements effective portioning of
storage space and superior accessibility from positions
convenient to the user.

25

Therefore, an object of the invention is to provide
a two-compartment trunk in which the upper compartment is

movable on the lower compartment to allow easy access
into both compartments.

Another object of the invention is to provide a
mechanism for stable and smooth movement of the upper
5 compartment.

Still another object of the invention is to provide
a trunk that maximizes storage space in the upper
compartment.

Still another object of the invention is to provide
10 a trunk that has accessibility to contents of the upper
compartment from either side of the vehicle.

Still another object of the invention is to provide
a trunk that has accessibility to the lower compartment
without bending over the upper compartment.

15 To achieve the above-described objects, the
invention provides a sliding tray trunk for a vehicle
that comprises a lower storage box attached to the
vehicle, an upper storage box slidably attached on top of
the lower storage box, and a stop device to limit sliding
20 of the upper storage box on the lower storage box to a
predetermined distance.

The sliding tray trunk also includes a sliding
device that enables sliding movement of the upper storage
box on the lower storage box.

25 The lower storage box has a substantially
rectangular shape, and has a front wall, a rear wall, two

side walls, a bottom wall, and a top wall. The top wall has an opening to allow access into the lower storage box, and one or more rails on which the upper storage box can slide. The two rails protrude upward from the top wall.

5 A plurality of wheels are rotatably attached on each of the rails, and the upper storage box slides by rotation of the wheels. Each of the plurality of wheels comprises a shaft rotatably attached on one of the rails, and a plastic ring surrounding the shaft and fixed to the
10 shaft. Preferably, the wheels are impregnated with grease.

The upper storage box has a substantially rectangular shape and comprises a front wall, a rear wall, two side walls, a bottom wall, and a cover. The cover is pivotally attached to the rear wall of the upper storage
15 box. The bottom wall of the upper storage box comprises two recesses for receiving the wheels of the lower storage box. Each of the recesses comprises a horizontal wall that contacts the wheels such that the wheels can roll on the horizontal wall when the upper storage box
20 slides, a vertical wall that extends downward from the horizontal wall, and a horizontal flange that extends horizontally from the vertical wall toward the rail.

Each of the recesses further comprises a vertical flange that extends downward from the horizontal wall,
25 and is oppositely positioned with the vertical wall such

that each of the recesses substantially surrounds the
wheels.

One or more gas-operated springs are installed
between the cover and the side walls of the upper storage
5 box to facilitate opening and closing of the cover.

The cover comprises a tool tray that is pivotally
attached under the cover. The tool tray pivots downward
when the cover is opened, and remains horizontal during
the full travel range of the cover between the closed and
10 open positions.

The cover further comprises reinforcements, and the
tool tray is positioned between the reinforcements.

The stop device of the sliding tray trunk includes
two spring-loaded handles positioned on the side walls of
15 the upper storage box, snap protrusions, a link
connecting the handles and the snap protrusions, and
recesses provided in one of the rails of the lower
storage box for receiving the snap protrusions. Grasping
one of the handles lifts the snap protrusions out of the
20 recesses so that the upper storage box can slide on the
rails, and releasing the handle makes the snap
protrusions snap into the recesses when the snap
protrusions are aligned with the recesses.

The recesses are positioned at the center of the
25 rail and at predetermined distances from the center of
the rail. Therefore, the upper storage box stops sliding

at the center of the rail or at the predetermined distances from the center.

To ensure safety related to the sliding operation of the upper storage box, the stop device further includes a first protrusion fixed at the bottom wall of the upper storage box near the front wall of the upper storage box, a first stop fixed at the top wall of the lower storage box near the front wall of the lower storage box, a second protrusion fixed at the bottom wall of the upper storage box near the rear wall of the upper storage box, and a second stop fixed at the top wall of the lower storage box near the rear wall of the lower storage box, in the manner that the sliding of the upper storage box is blocked when the first protrusion abuts the first stop, or the second protrusion abuts the second stop allowing the upper storage box to be slid in either direction with a positive safety stop limiting travel.

The cover of the upper storage box has a top plate and two side plates connected with the top plate. When the cover is closed, the side plates are positioned near ends of the rails, and block sliding of the upper storage box.

The front wall of the upper storage box has a pin, and the cover of the upper storage box has a latch engaging with the pin so that the cover of the upper

1468.03CAN

storage box can be locked to and unlocked from the upper
storage box.

The advantages of the present invention are numerous
in that: (1) the user can access into the upper storage
5 box outside the bed of the truck; (2) use of the space
inside the upper storage box is maximized; (3) the user
can access into the lower storage box without climbing
onto the bed; (4) although the user will still need to
bend over the side of the vehicle to access the contents
10 of the lower box but he/she will not have to reach over
the lip or side of the upper storage box because it has
been pushed away; and (5) the user can access into the
trunk at either side of the truck.

Although the present invention is briefly summarized,
15 the fuller understanding of the invention can be obtained
by the following drawings, detailed description and
appended claims.

BRIEF DESCRIPTION OF THE DRAWINGS

20 These and other features, aspects and advantages of
the present invention will become better understood with
reference to the accompanying drawings, wherein:

Fig. 1 is a side elevational view of a vehicle on
which the sliding tray trunk of the present invention is
25 installed;

Fig. 2 is a rear elevational view of the vehicle and the trunk showing a lower storage box, and an upper storage box;

Fig. 3 is a front elevational view of the trunk with
5 the upper storage box locked;

Fig. 4 is a side elevational view of the trunk;

Fig. 5 is a front elevational view of the trunk with the upper storage box slid to the driver's side;

Fig. 6 is a front elevational view of the trunk with
10 the upper storage box slid to the passenger's side;

Fig. 7 is a top view of the trunk with the upper storage box slid to the passenger's side;

Fig. 8 is a cross-sectional view taken along the line 8-8 of Fig. 3;

Fig. 9 is an enlarged cross-sectional view of the
15 circled portion of Fig. 8;

Fig. 10 is a top view of the lower storage box;

Fig. 11 is a side elevational view of the upper storage box with the cover fully opened;

Fig. 12 is a top view of the upper storage box with
20 the cover fully opened;

Fig. 13 is a side elevational view of the upper storage box with the cover closed;

Fig. 14 is a view similar to Fig. 13 but with the
25 cover opened and the tool tray is lowered;

Fig. 15 is a rear view of the trunk with the upper storage box slid to the driver's side, and the cover open;

Fig. 16 is a schematic elevational view showing a stop device for the sliding tray trunk;

Fig. 17 is a schematic plan view showing a safety stop for the sliding tray trunk when the upper storage box is centered;

Fig. 18 is a schematic plan view showing the safety stop when the upper storage box is slid to the driver's side; and

Fig. 19 is a schematic elevational view showing the safety stop.

DETAILED DESCRIPTION OF THE PREFERRED EMBODIMENTS

Fig. 1 shows a pick up truck on which a sliding tray trunk 10 of the present invention is installed. Fig. 2 shows the trunk 10 has a lower storage box 12 and an upper storage box 14. The lower storage box 12 is mounted on the sides of the pickup truck and is suspended over the bed.

The upper storage box 14 is slidably attached to the lower storage box 12 with a sliding device 15.

Figs. 3 and 4 show that the upper storage box 14 is secured on top of the lower storage box 12. Except when a user wants to access the contents in either of the upper

storage box 14 and the lower storage box 12, the upper
storage box 14 is secured to the lower storage box 12 by
a lock that is explained later referring to Fig. 15. The
lock also prevents the upper storage box 14 from rattling
5 when the truck moves.

Fig. 5 shows that the upper storage box 14 is slid
to the left. This corresponds to driver's side of the
vehicle and the street side. Figs. 6 and 7 show that the
upper storage box 14 is slid to the right. This
10 corresponds to passenger's side of the vehicle and the
curbside. The sliding distance of the upper storage box
14 is limited to a predetermined distance by a stop
device that is explained later referring to Figs. 16 and
17. The predetermined distance is chosen such that the
15 upper storage box 14 is rigidly supported by the lower
storage box 12 even when the upper storage box 14 is slid
up to the predetermined distance. Preferably, the
predetermined distance is two thirds of the length of the
upper storage box 14.

20 Figs. 8 and 9 show a mechanism for sliding the upper
storage box 14 on top of the lower storage box 12. The
lower storage box 12 has a substantially rectangular
shape, and comprises a front wall 16, a rear wall 18, two
side walls 20 (refer to Figs. 5 and 6), a bottom wall 24,
25 and a top wall 26. The top wall 26 comprises an opening
28 to allow access into the lower storage box 12. The

sliding device 15 includes two rails 30 on which the upper storage box 14 can slide. The two rails 30 protrude upward from the top wall 26 and extend parallel with the front wall 16 and the rear wall 18.

5 As shown in Figs. 9 and 10, a plurality of wheels 32 are rotatably attached on each of the rails 30, and the upper storage box 14 slides on the lower storage box 12 by rotation of the wheels 32. Preferably, the number of wheels 32 is twelve on each rail 30. The number of wheels
10 may vary with the design size of the storage trunk in order to accommodate various vehicle sizes.

Each of the plurality of wheels 32 comprises a shaft 34 rotatably attached on one of the rails 30, and a plastic ring 36 surrounding the shaft 34 and fixed to the
15 shaft 34. The plastic ring 36 provides smooth and silent sliding movement of the upper storage box 14. Preferably, the plastic ring 36 is made of Nylon. The wheels 32 may be impregnated with grease. Thus, the wheels 32 are self-lubricated, and rattles and squeaks are inhibited
20 further.

As shown in Figs. 11 and 12, the upper storage box 14 has a substantially rectangular shape and comprises a front wall 38, a rear wall 40, two side walls 42, a bottom wall 44, and a cover 46. The cover 46 is pivotally
25 attached to the rear wall 40.

Referring back to Figs. 8 and 9, the bottom wall 44 has two recesses 48 for receiving the wheels 32 of the lower storage box 12. Each of the recesses 48 has a horizontal wall 50 that contacts the wheels 32 such that the wheels 32 can roll on the horizontal wall 50 when the upper storage box 14 slides, a vertical wall 52 that extends downward from the horizontal wall 50, a horizontal flange 54 that extends horizontally from the vertical wall 52 toward the rail 30. The horizontal flange 54 prevents the upper storage box 14 from being lifted upward from the lower storage box 12. The recess 48 further has a vertical flange 56 that extends downward from the horizontal wall 50, and is oppositely positioned with the vertical wall 52 such that the recess 48 substantially surrounds the wheel 32. In this way, the upper storage box 14 is properly guided when it is slid. The wheels 32 provide smooth movement of the upper storage box 14. The clearances or tolerances between the wheels 32 and the vertical wall 52 and the horizontal flange 54 are made as small as possible, thereby minimizing lateral or vertical movement of the upper storage box 14 in relation to the lower storage box 12. The wheels 32 and the recesses 48 rigidly support the upper storage box 14 even when the upper storage box 14 is slid to the fully opened position.

Fig. 14 and 15 show that two gas-operated springs 58 are installed between the cover 46 and the side walls 42 of the upper storage box 14 to facilitate opening and closing of the cover 46.

5 A tool tray 60 is pivotally attached under the cover 46. The tool tray 60 provides a storage space for frequently used tools. The tool tray 60 pivots downward when the cover 46 is opened, and becomes and remains horizontal during the full travel range of the cover 46
10 between the closed and open position. This pivoting of the tool tray 60 may be guided and limited by a wire, a rope or a hinge.

The cover 46 further has reinforcements 62 to strengthen the cover 46. The tool tray 60 is positioned
15 between the reinforcements 62.

Fig. 16 shows that the stop device of the trunk 10 includes two spring-loaded handles 64 positioned on the side walls 42 of the upper storage box 14, a plurality of snap protrusions 66, a link 68 connecting the handles 64
20 and the snap protrusions 66, and a plurality of recesses 70 provided in one of the rails 30 of the lower storage box 12 for receiving the snap protrusions 66. The handles 64 are spring-loaded by springs 72.

In order to slide the upper storage box 14, the user
25 grasps and lifts the handle 64 on either side of the truck. Then the link 68 lifts the snap protrusions 66 out

of the recesses 70 so that the upper storage box 14 can slide on the rails 30. When the user releases the handle 64, by the returning force of the springs 72, the link 68 forces the snap protrusions 66 down, and the snap protrusions 66 snap into the recesses 70 as soon as the snap protrusions 66 are aligned with the recesses 70, and the sliding stops. The recesses 70 are positioned at the center of the rail 30 and at predetermined distances from the center of the rail 30. In this way, the upper storage box 14 stops sliding at the center of the rail 30 or at the predetermined distances from the center of the rail 30. The predetermined distances correspond to being slid one-half open or full opened. Even if the cover 46 was inadvertently left open and the driver moved the vehicle causing the upper storage box 14 to slide in either direction, the sliding would stop when the snap protrusions 66 snap into the nearest recesses 70.

Figs. 17 - 19 show a safety stop that prevents the upper storage box 14 from separating from the lower storage box 12 and falling to the ground. The safety stop includes a first protrusion 74 fixed at the bottom wall 44 of the upper storage box 14 near the front wall 38 of the upper storage box 14, a first stop 76 fixed at the top wall 26 of the lower storage box 12 near the front wall 16 of the lower storage box 12, a second protrusion 78 fixed at the bottom wall 44 of the upper storage box

14 near the rear wall 40 of the upper storage box 14, and
a second stop 80 fixed at the top wall 26 of the lower
storage box 12 near the rear wall 18 of the lower storage
box 12. In this way, the sliding of the upper slide box
5 14 is blocked when the first protrusion 74 abuts the
first stop 76 in case that the upper storage box 14 is
slid to the driver side as shown in Figs. 18 and 19, or
when the second protrusion 78 abuts the second stop 80 in
case that the upper storage box 14 is slid to the
10 passenger side. The protrusions 74, 78 and stops 76, 80
are positioned to prevent the upper storage box 14 from
sliding further than the fully opened position of the
stop device.

Referring back to Figs. 13 - 15, the cover 46 of the
15 upper storage box 14 has a top plate 82, a front plate 84
and two side plates 86 connected with the top plate 82
and the front plate 84. When the cover 46 is closed, the
side plates 86 are positioned near ends of the rails 30,
and block sliding of the upper storage box 14. Fig. 3
20 shows this state. The cover 46 can be closed only when
the upper storage box 14 is centered on the lower storage
box 12.

Fig. 15 shows that the cover 46 of the upper storage
box 14 has one or more latches or locks 88 on its front
25 plate 84, and the front wall 38 of the upper storage box
14 has one or more pins 90 engaging with the latches 88

1468.03CAN

so that the cover 46 of the upper storage box 14 can be locked to and unlocked from the upper storage box 14. A commercially available rotary latch can be used as the latch 88.

5 With the above trunk, the necessity of climbing onto the bed of the vehicle and reaching over the higher side of the top portion of the trunk is eliminated. The trunk allows for increased and segregated storage in the upper sliding storage box of the trunk. The trunk allows making
10 use of full space inside the upper storage box since the user can access into the lower storage box without passing through the upper storage box. Since the upper storage box can be pulled out over either side of the vehicle, all contents stored in the upper storage box can
15 be easily reached with no need to walk around to the far side of the vehicle, and the user can choose street or curbside access depending on the user's preference and working conditions. Sliding away of the upper storage box either toward or away from user allows easy access to
20 contents stored in the lower storage box from either side of the vehicle. Sliding the upper storage box allows the user to access the contents of the lower storage box without reaching over the additional height of the upper storage box thus allowing further reach into the middle
25 of the lower storage box. Access to the lower storage box is improved particularly on vehicles with higher bed

sides. The trunk allows for separation of small tools and equipment from large and/or bulky items. The trunk also facilitates access to the stored contents even when the vehicle bed is filled with items.

5 The upper storage box will slide off either side of the vehicle allowing the user to stand directly in front of and over items stored without having to reach over and across the bed of the carrying vehicle. The sliding of the storage box allows access to items stored opposite
10 the user's position without requiring the user to walk around to the other side of the vehicle to access items on that side of the storage tray. Because no access to the lower storage box is required through the upper storage box, the use of storage space in the upper
15 storage box can be maximized, and the upper storage box can be organized to fit any manner of trade or hobby as the user may wish through the user of dividers, additional trays, removable trays, mounting points, etc. Because there is no need to reach through the top portion
20 of the trunk to get to the contents of the lower portion of the trunk, a permanent bottom is allowed on the upper storage box across the entire length thereof. This full bottom along the entire length may be used for attaching permanent mounting brackets for small tools.

25 While the sliding tray trunk illustrated in the drawings are shown with the upper storage box moves side

by side with respect to the vehicle, the sliding tray trunk can be installed in any direction so that the upper storage box can move in any direction including front-to-rear direction with respect to the vehicle.

5 Although the invention has been described in considerable detail, other versions are possible by converting the aforementioned construction. Therefore, the scope of the invention shall not be limited by the specification specified above.

10

What is claimed is:

1. A sliding tray trunk for a vehicle comprising:

a) a lower storage box;

5 b) an upper storage box slidably attached on top of the lower storage box; and

c) a stop device to limit sliding of the upper storage box on the lower storage box
to a predetermined distance;

10 wherein the lower storage box has a substantially rectangular shape, and comprises a front wall, a rear wall, two side walls, a bottom wall, and a top wall, wherein the top wall comprises an opening to allow access into the lower storage box, and two rails on which the upper storage box can slide, and wherein the two rails protrude upward from the top wall and extend parallel with the front wall and the rear wall.

15 2. The sliding tray trunk of claim 1 wherein a plurality of wheels are rotatably attached on each of the rails, and the upper storage box slides by rotation of the wheels.

20 3. The sliding tray trunk of claim 2 wherein each of the plurality of wheels comprises a shaft rotatably attached on one of the rails, and a plastic ring surrounding the shaft and fixed to the shaft.

25 4. The sliding tray trunk of any one of claims 2 or 3 wherein the upper storage box has a substantially rectangular shape and comprises a front wall, a rear wall, two side walls, a bottom wall, and a cover, wherein the cover is pivotally attached to the rear wall of the upper storage box, wherein the bottom wall of the upper storage box comprises two recesses for receiving the wheels of the lower storage box.

5. The sliding tray trunk of claim 4 wherein one or more gas-operated springs are installed between the cover and the side walls of the upper storage box to facilitate opening and closing of the cover.
- 5
6. The sliding tray trunk of claim 4 wherein the cover comprises a tool tray that is pivotally attached under the cover.
7. The sliding tray trunk of claim 6 wherein the tool tray pivots downward when the cover is opened, and is kept horizontal during the full travel range of the cover.
- 10
8. The sliding tray trunk of any one of claims 6 or 7 wherein the cover further comprises reinforcements, and the tool tray is positioned between the reinforcements.
- 15
9. The sliding tray trunk of any one of claims 4 to 8 wherein the stop device comprises two spring-loaded handles positioned on the side walls of the upper storage box, a plurality of snap protrusions, a link connecting the handles and the snap protrusions, and a plurality of recesses provided in one of the rails of the lower storage box for receiving the snap protrusions, wherein grasping one of the handles lifts the snap protrusions out of the recesses so that the upper storage box can slide on the rails, and releasing the handle makes the snap protrusions snap into the recesses when the snap protrusions are aligned with the recesses.
- 20
10. The sliding tray trunk of claim 9 wherein the recesses are positioned at the center of the rail and at predetermined distances from the center of the rail, whereby the upper
- 25

storage box stops sliding at the center of the rail or at the predetermined distances from the center.

11. The sliding tray trunk of any one of claims 4 to 8 wherein the stop device comprises a first protrusion fixed at the bottom wall of the upper storage box near the front wall of the upper storage box, a first stop fixed at the top wall of the lower storage box near the front wall of the lower storage box, a second protrusion fixed at the bottom wall of the upper storage box near the rear wall of the upper storage box, and a second stop fixed at the top wall of the lower storage box near the rear wall of the lower storage box, in the manner that the sliding of the upper storage box is blocked when the first protrusion abuts the first stop, or the second protrusion abuts the second stop.
12. The sliding tray trunk of any one of claims 9 or 10 wherein the stop device further comprises a first protrusion fixed at the bottom wall of the upper storage box near the front wall of the upper storage box, a first stop fixed at the top wall of the lower storage box near the front wall of the lower storage box, a second protrusion fixed at the bottom wall of the upper storage box near the rear wall of the upper storage box, and a second stop fixed at the top wall of the lower storage box near the rear wall of the lower storage box, in the manner that the sliding of the upper storage box is blocked when the first protrusion abuts the first stop, or the second protrusion abuts the second stop.
13. The sliding tray trunk of any one of claims 4 to 12 wherein the cover of the upper storage box has a top plate and two side plates connected with the top plate, wherein

when the cover is closed, the side plates are positioned near ends of the rails, and the side plates prevent sliding of the upper storage box on the rails.

14. The sliding tray trunk of any one of claims 4 to 13 wherein the cover of the upper
5 storage box has a latch, and the front wall of the upper storage box has a pin engaging
with the latch so that the cover of the upper storage box can be locked to and
unlocked from the upper storage box.
15. The sliding tray trunk of any one of claims 2 to 14 wherein the wheels are
10 impregnated with grease.

1/8

Fig. 1

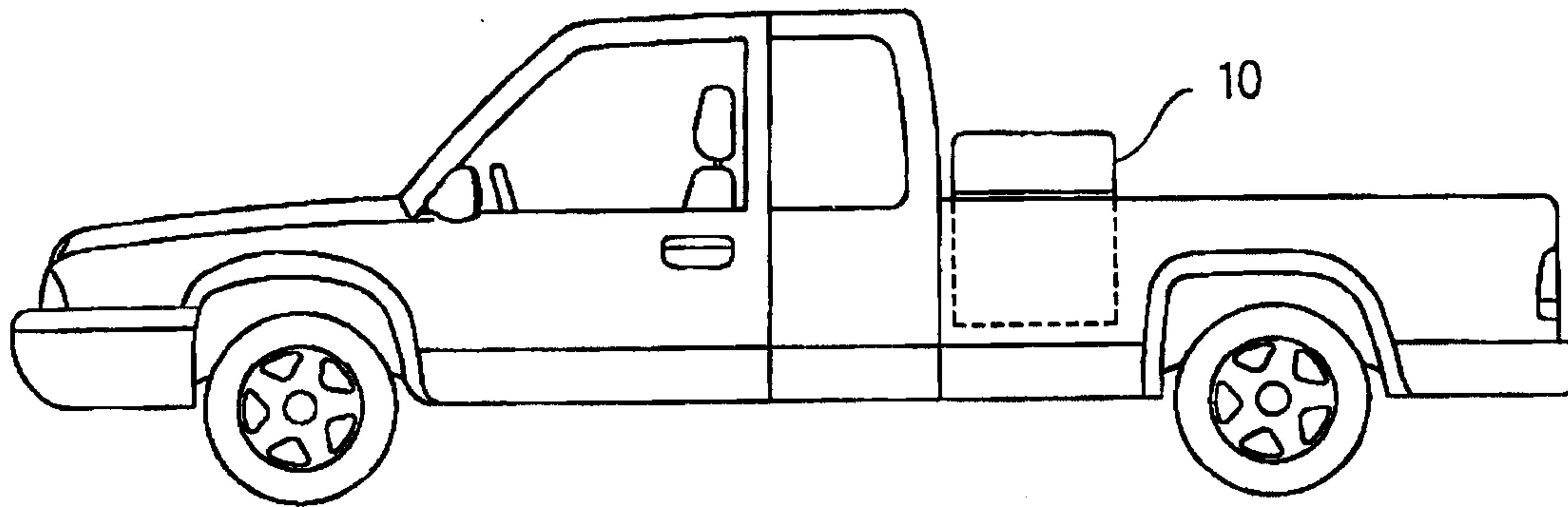
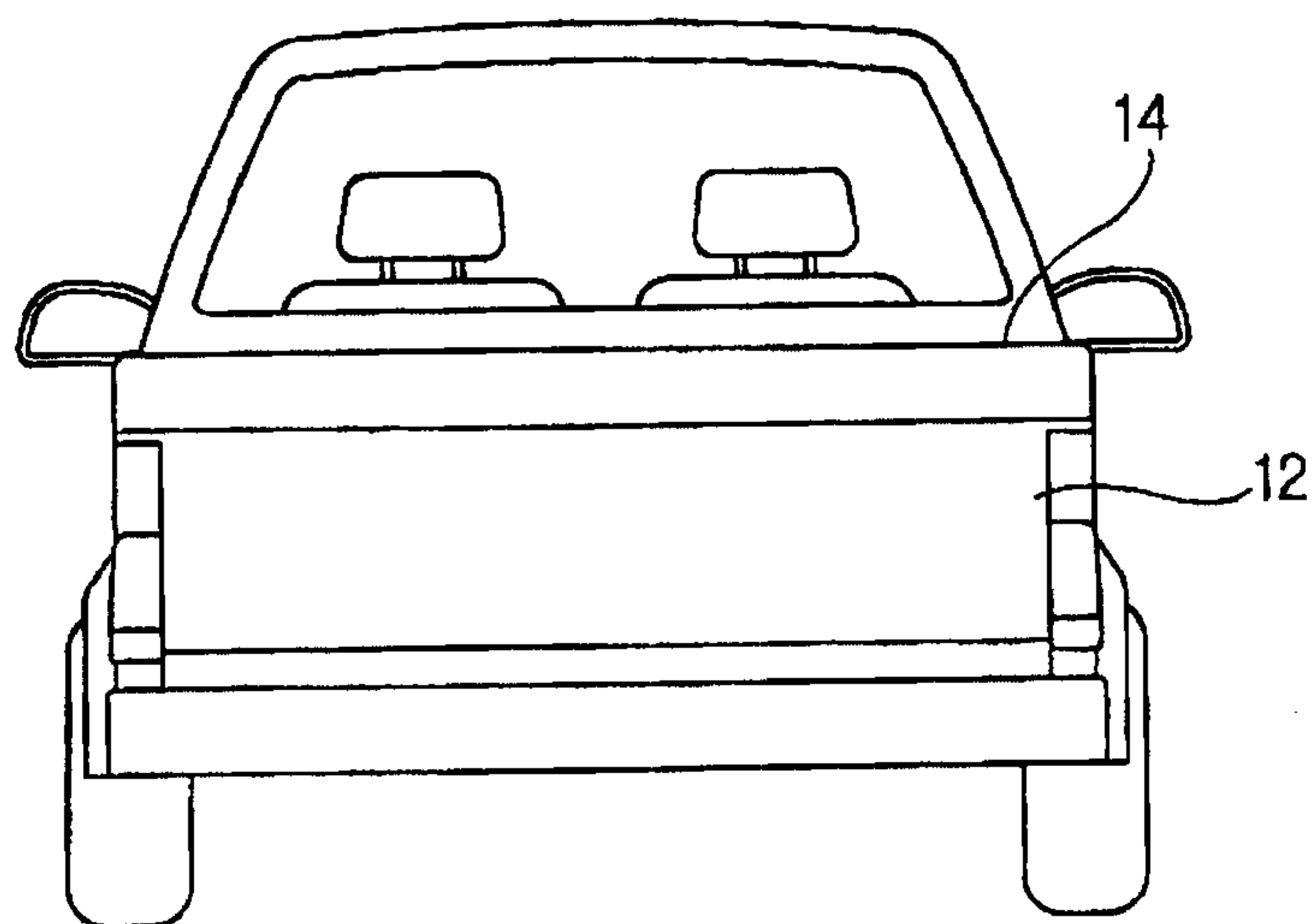

Fig. 2



2/8

Fig. 3

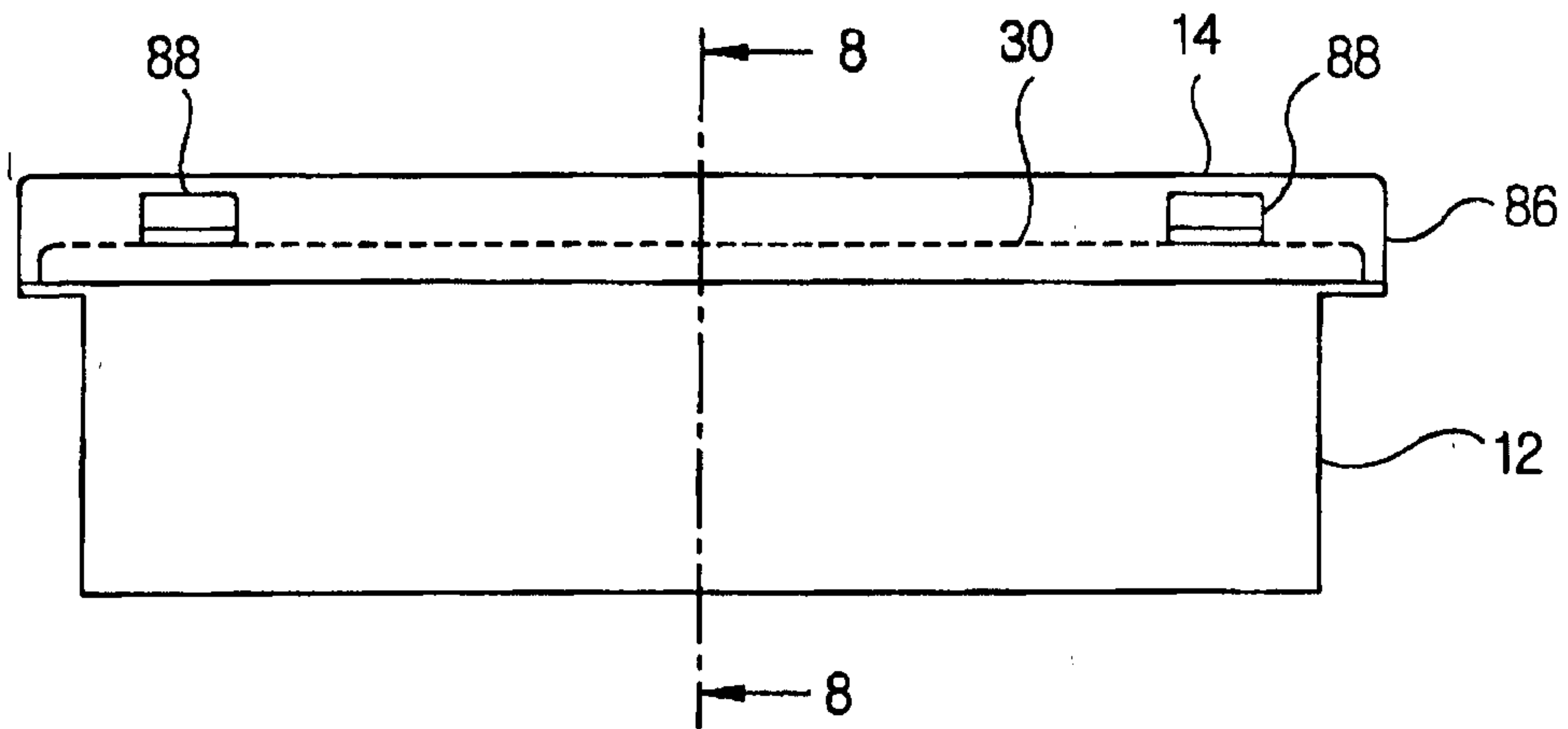
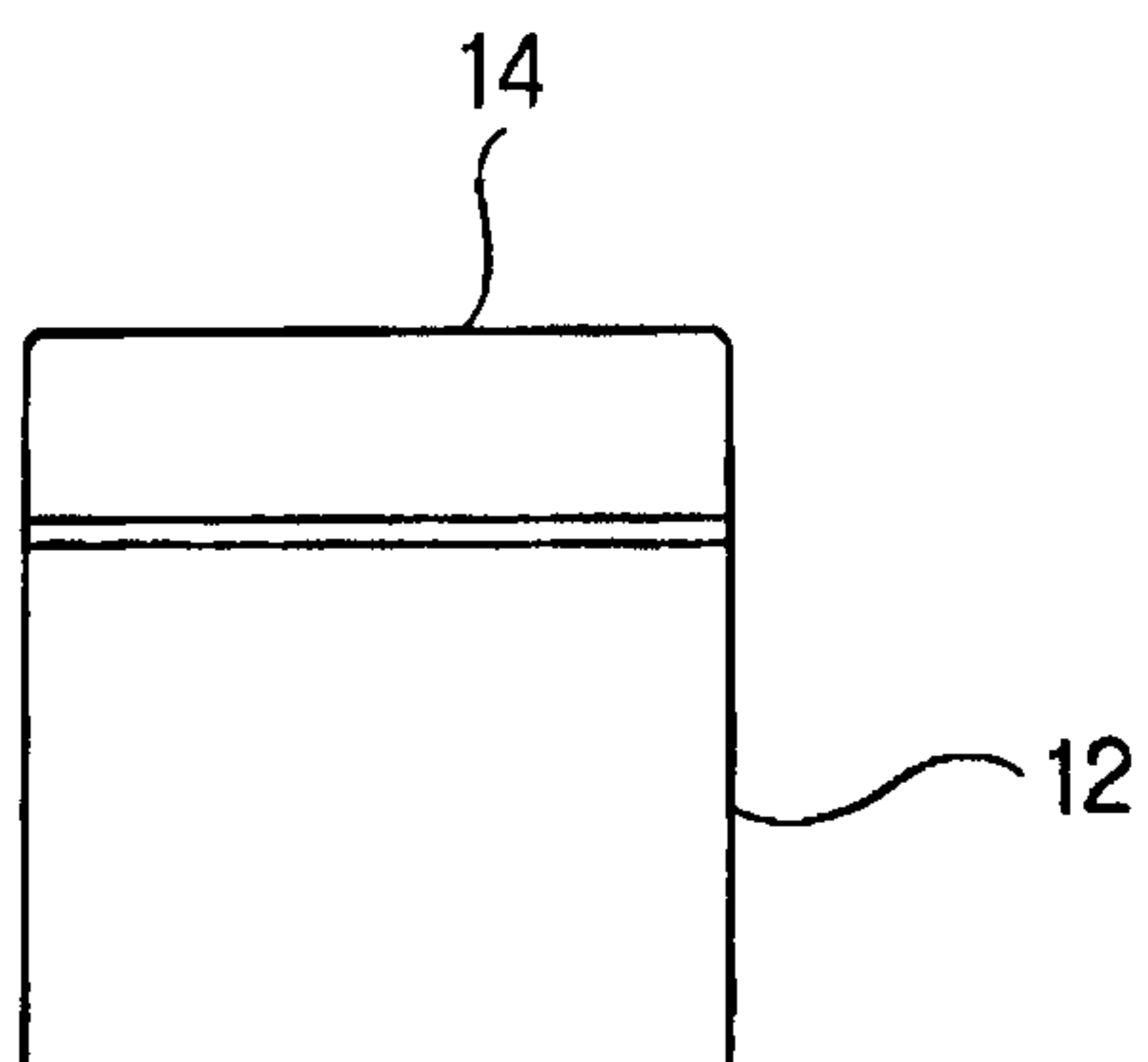

Fig. 4



3/8

Fig. 5

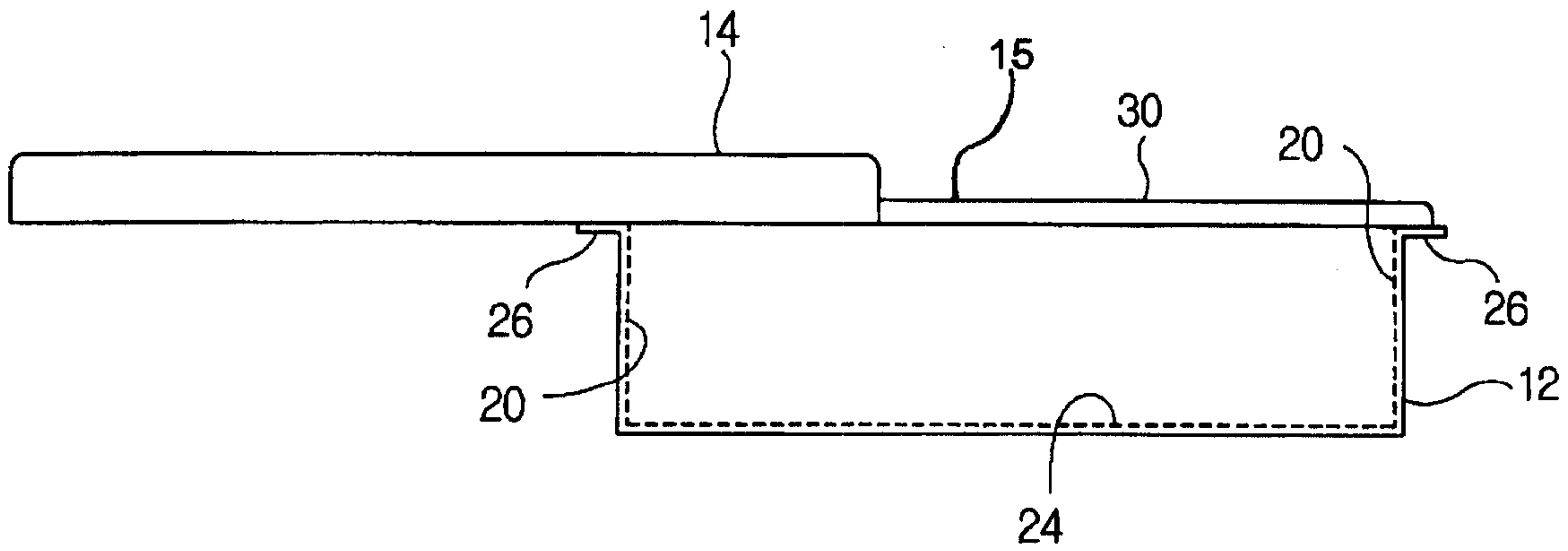

Fig. 6

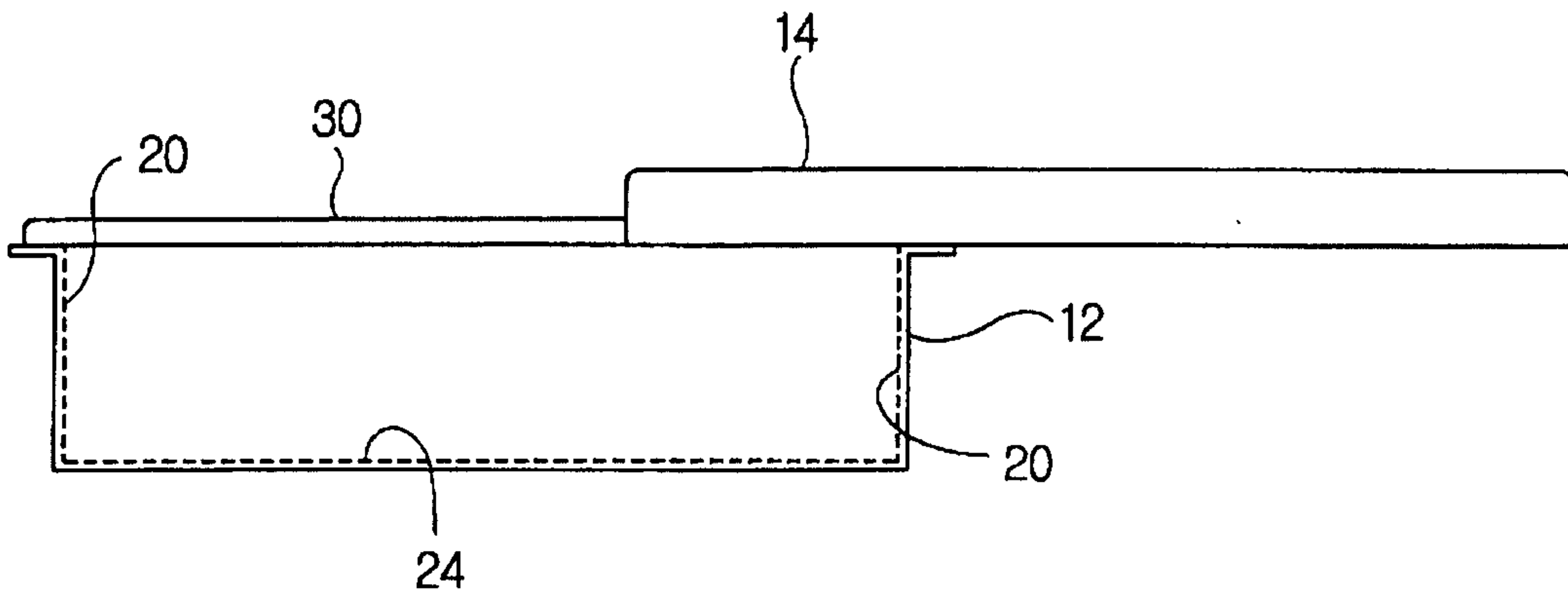
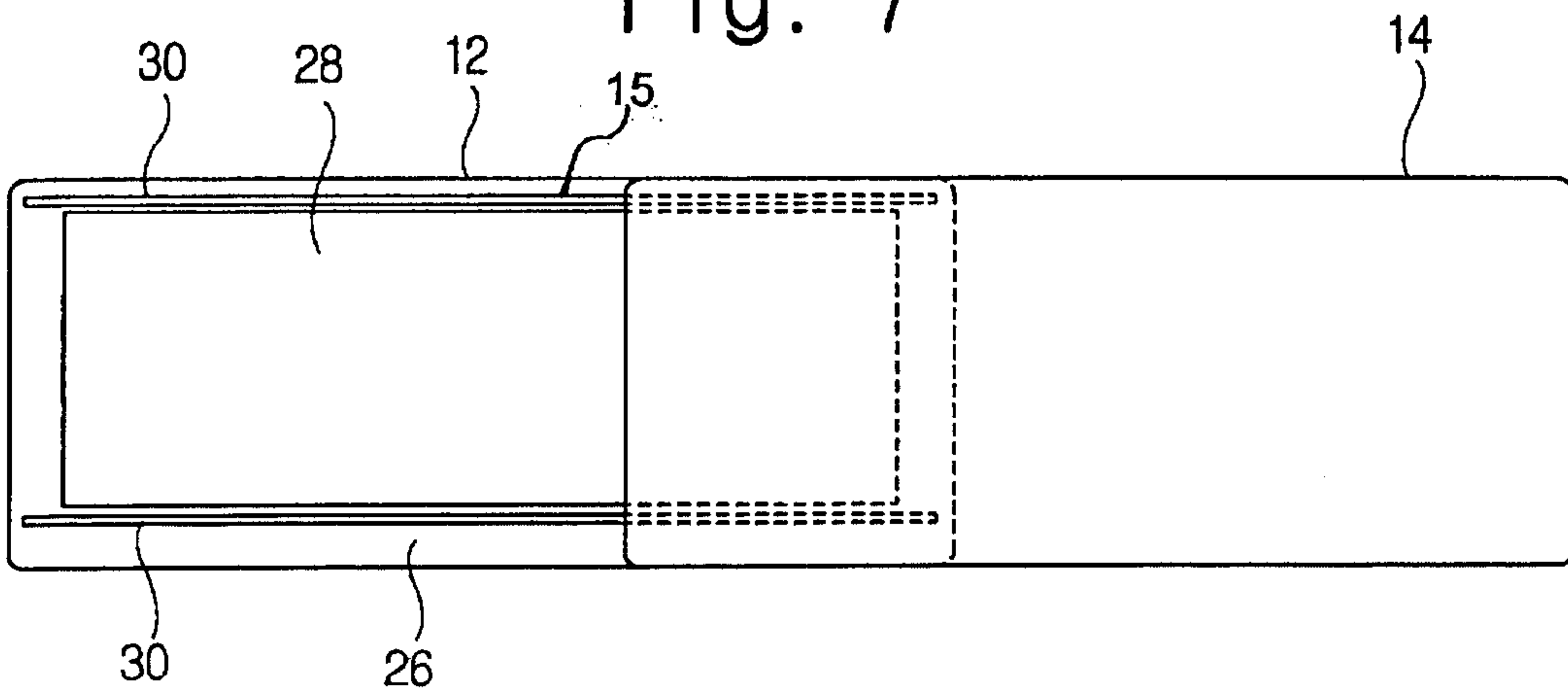

Fig. 7



4/8

Fig. 8

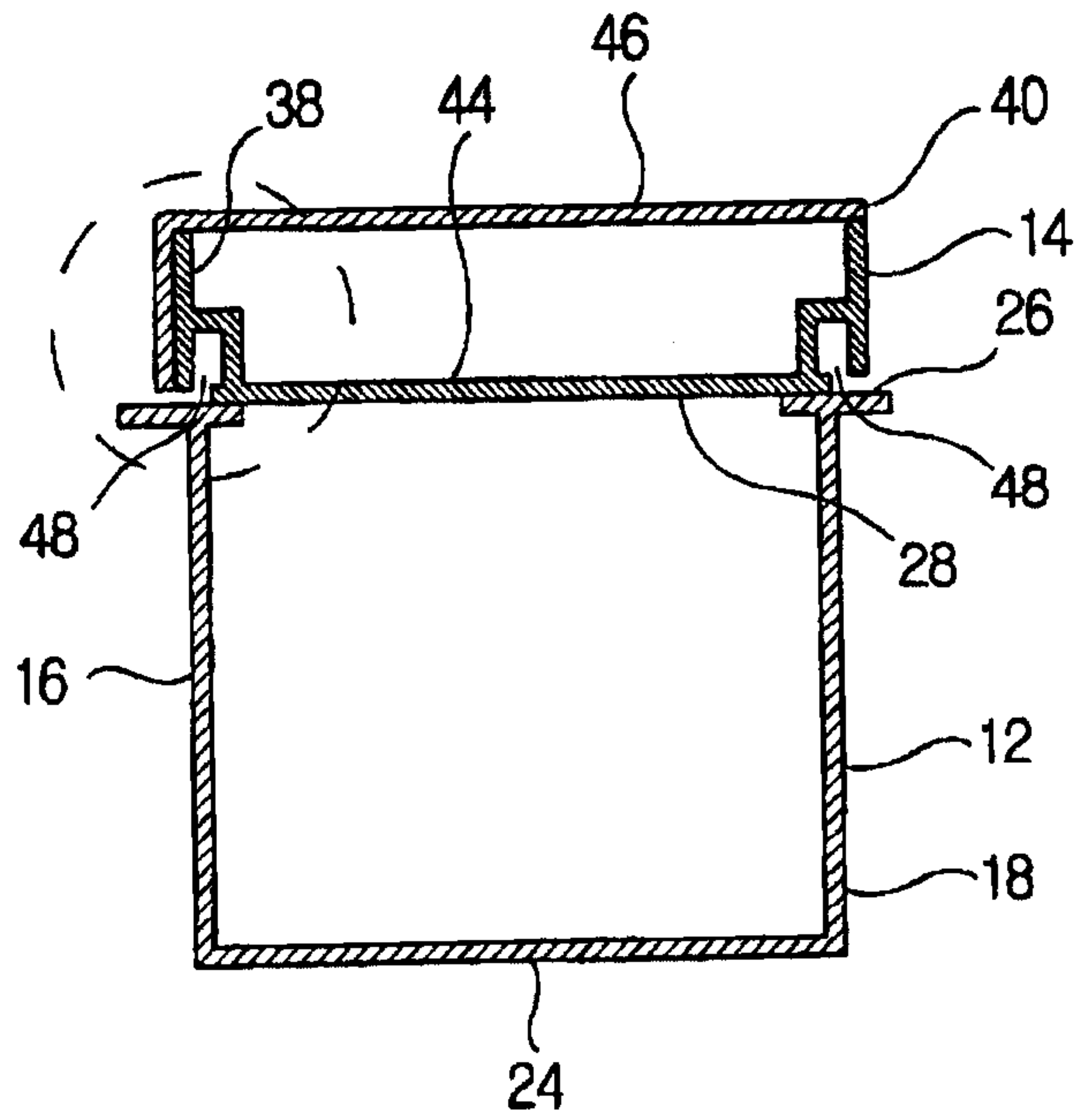
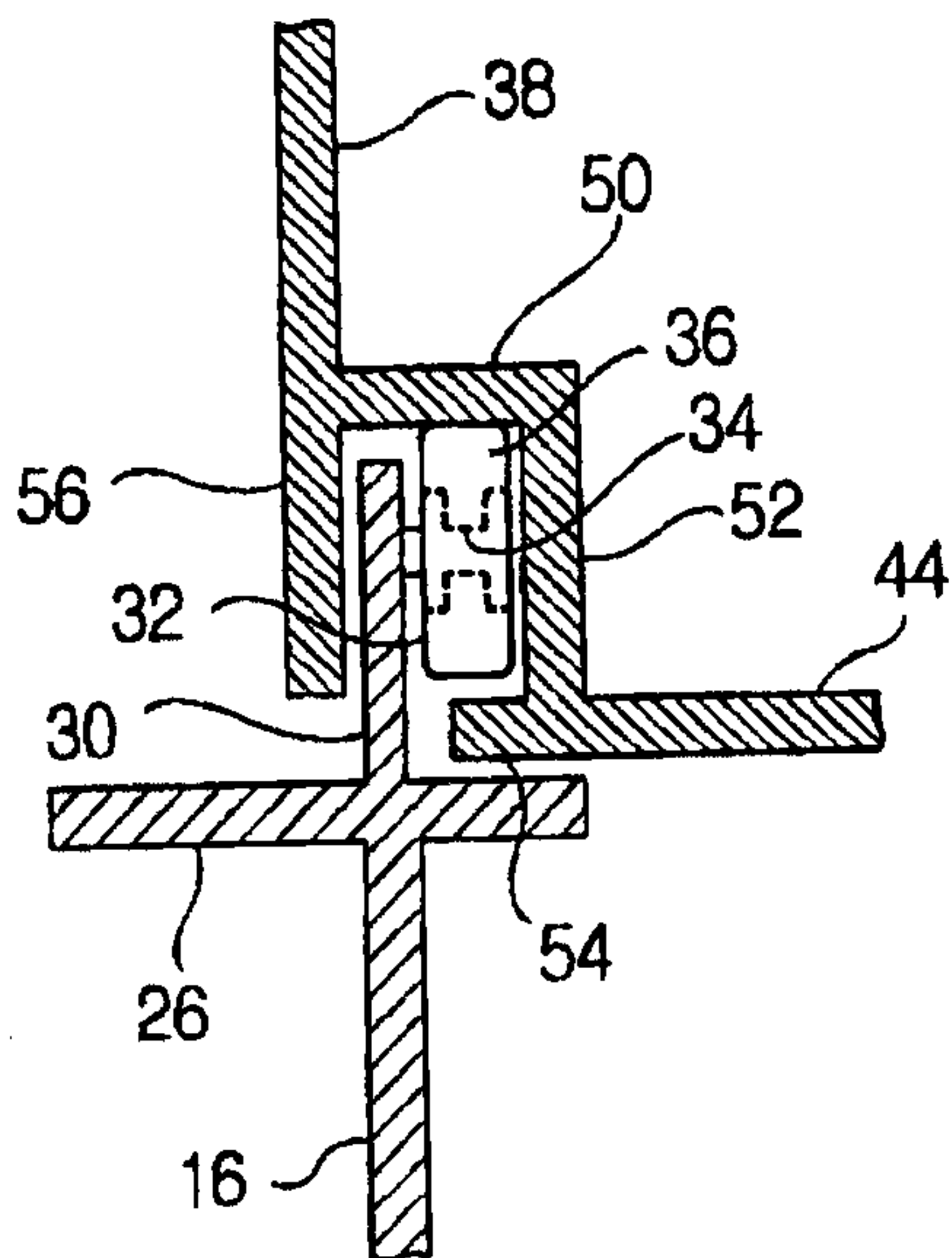

Fig. 9



5/8

Fig. 10

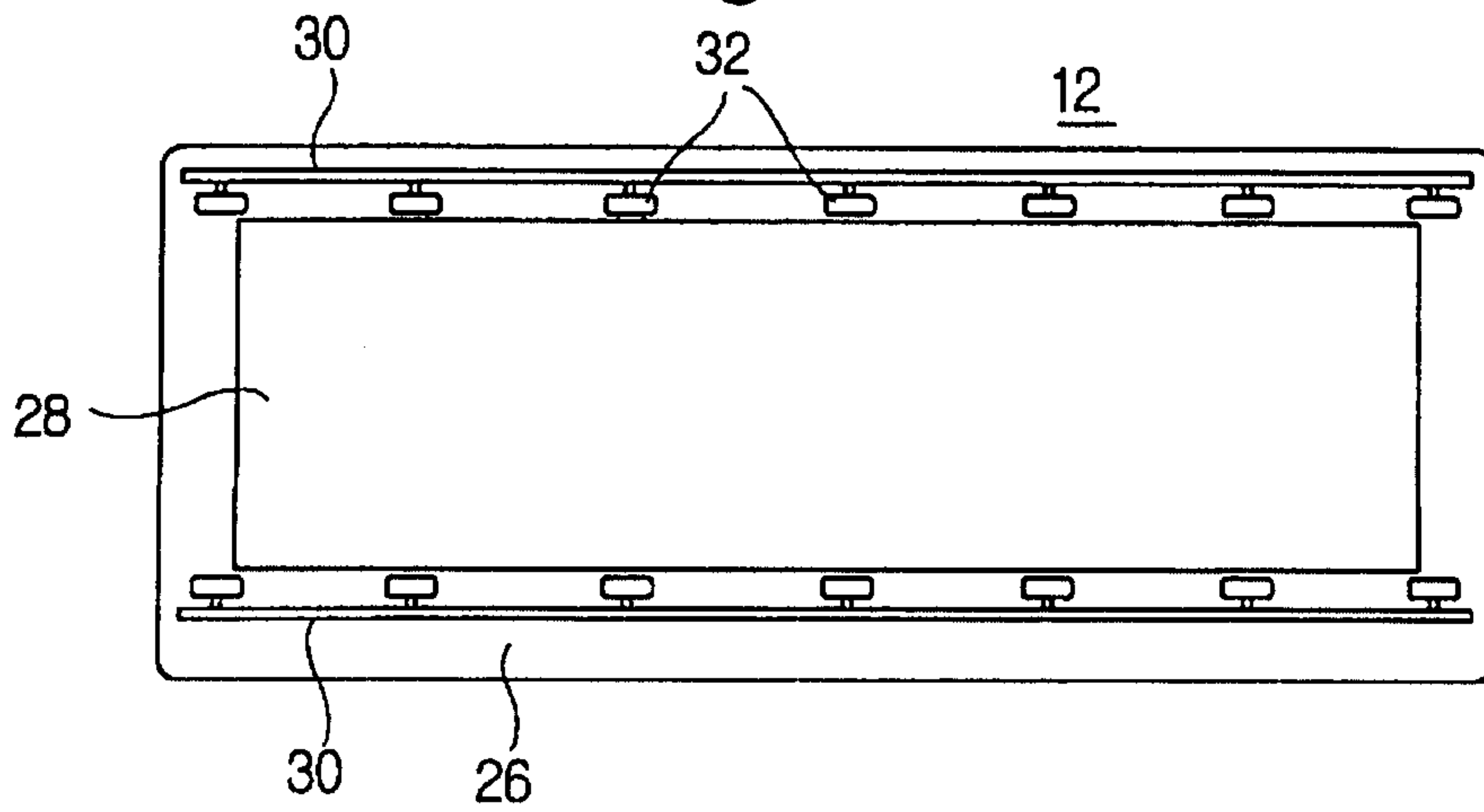

Fig. 11

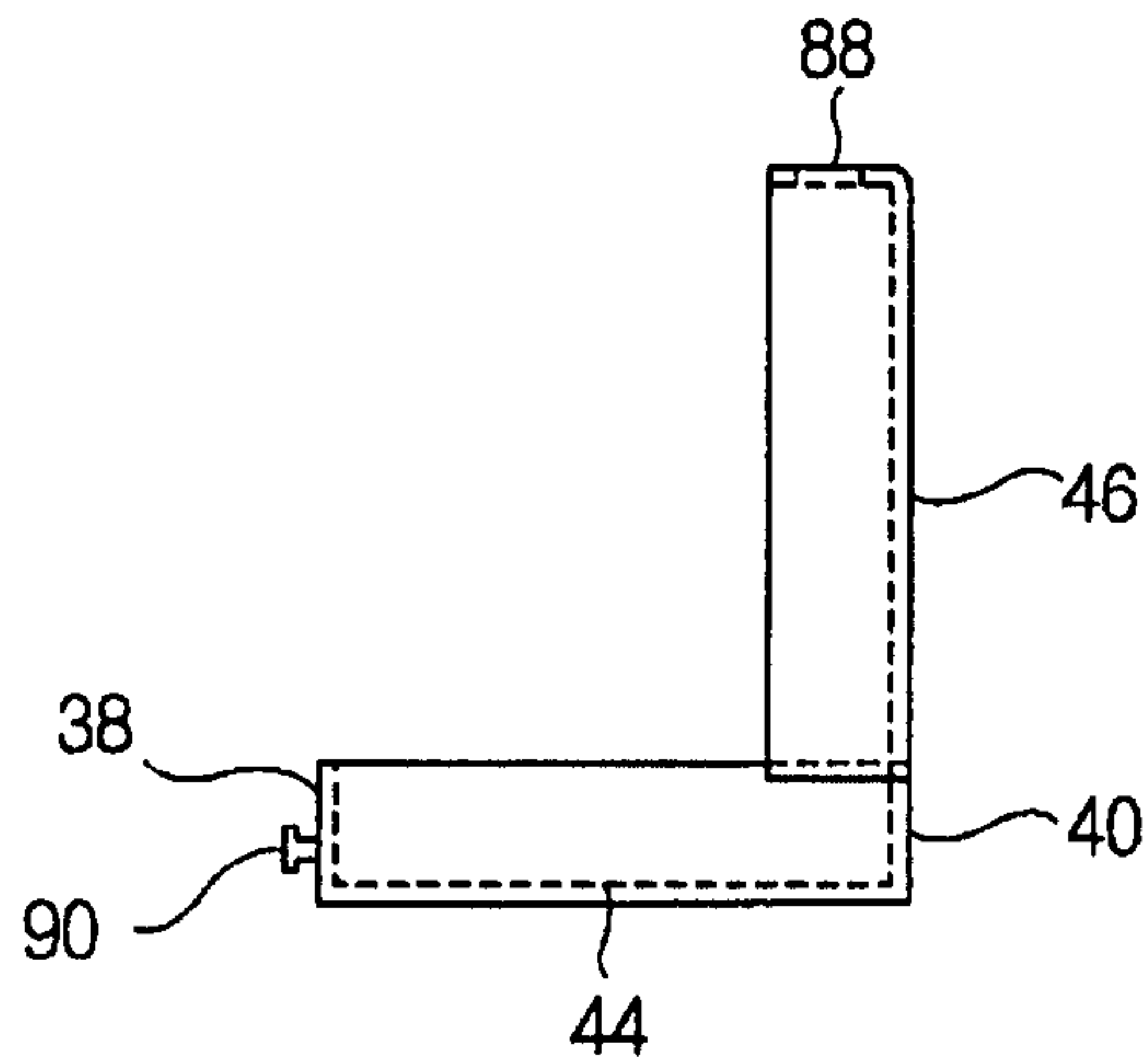

Fig. 12

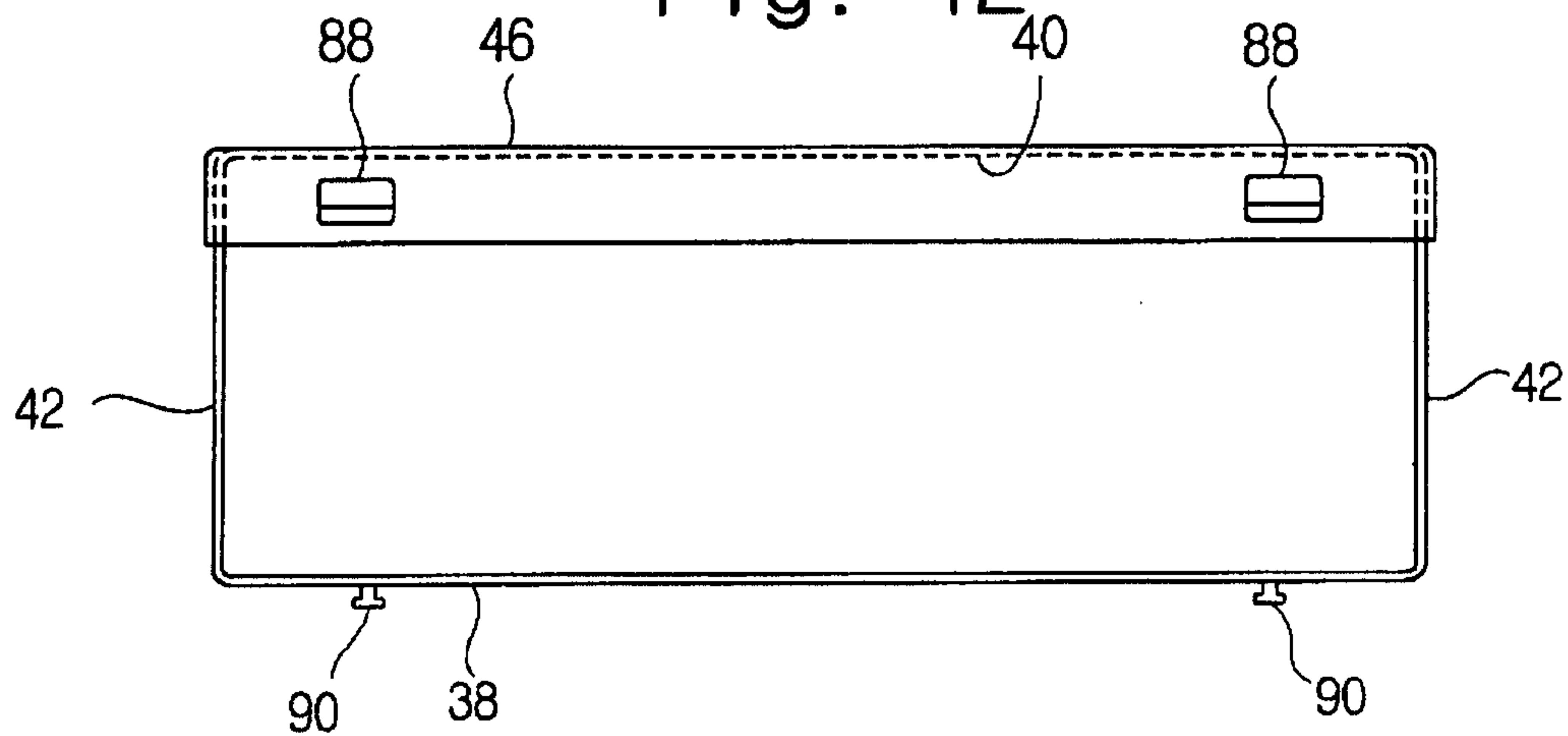

Fig. 13

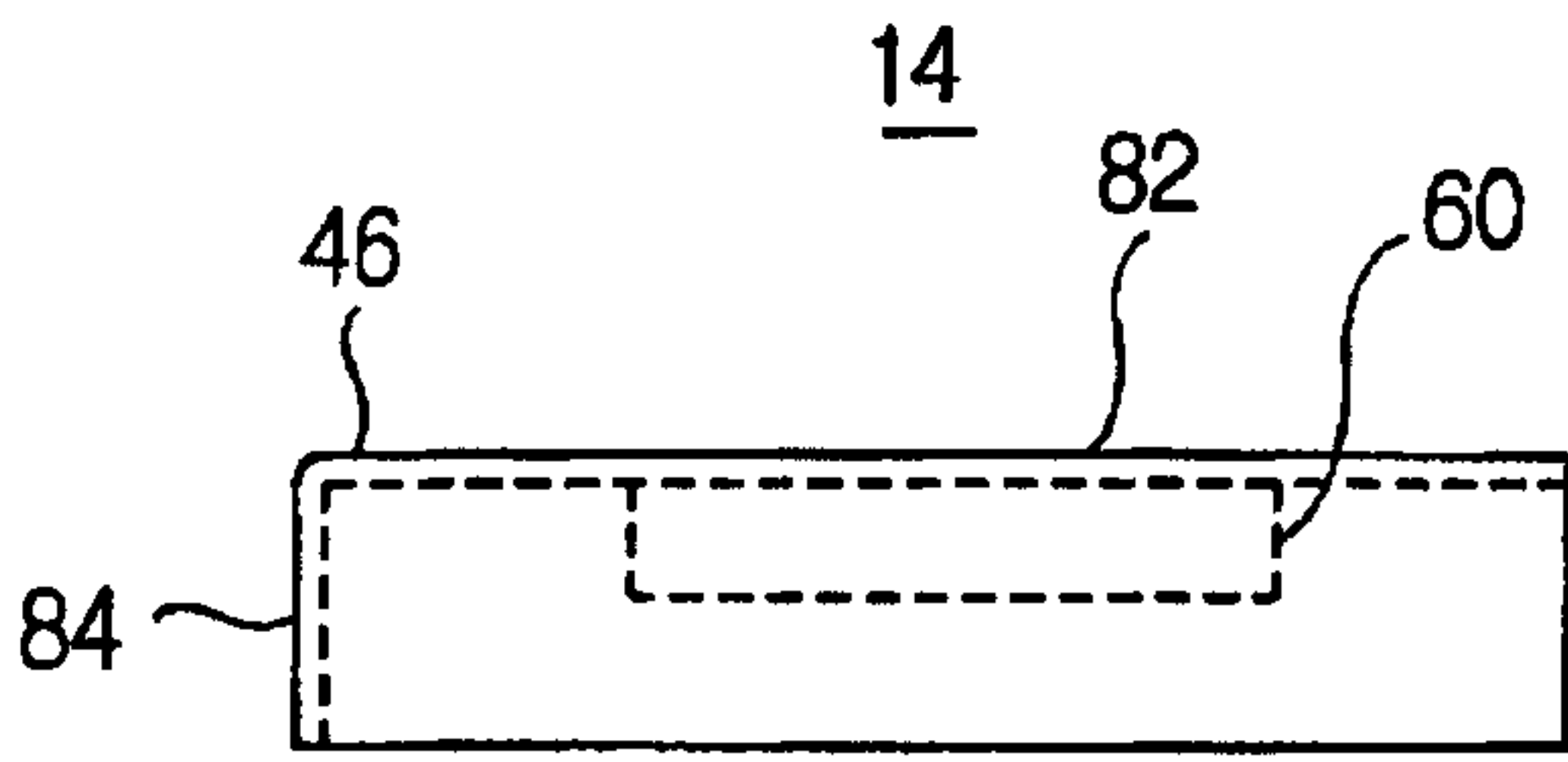

Fig. 14

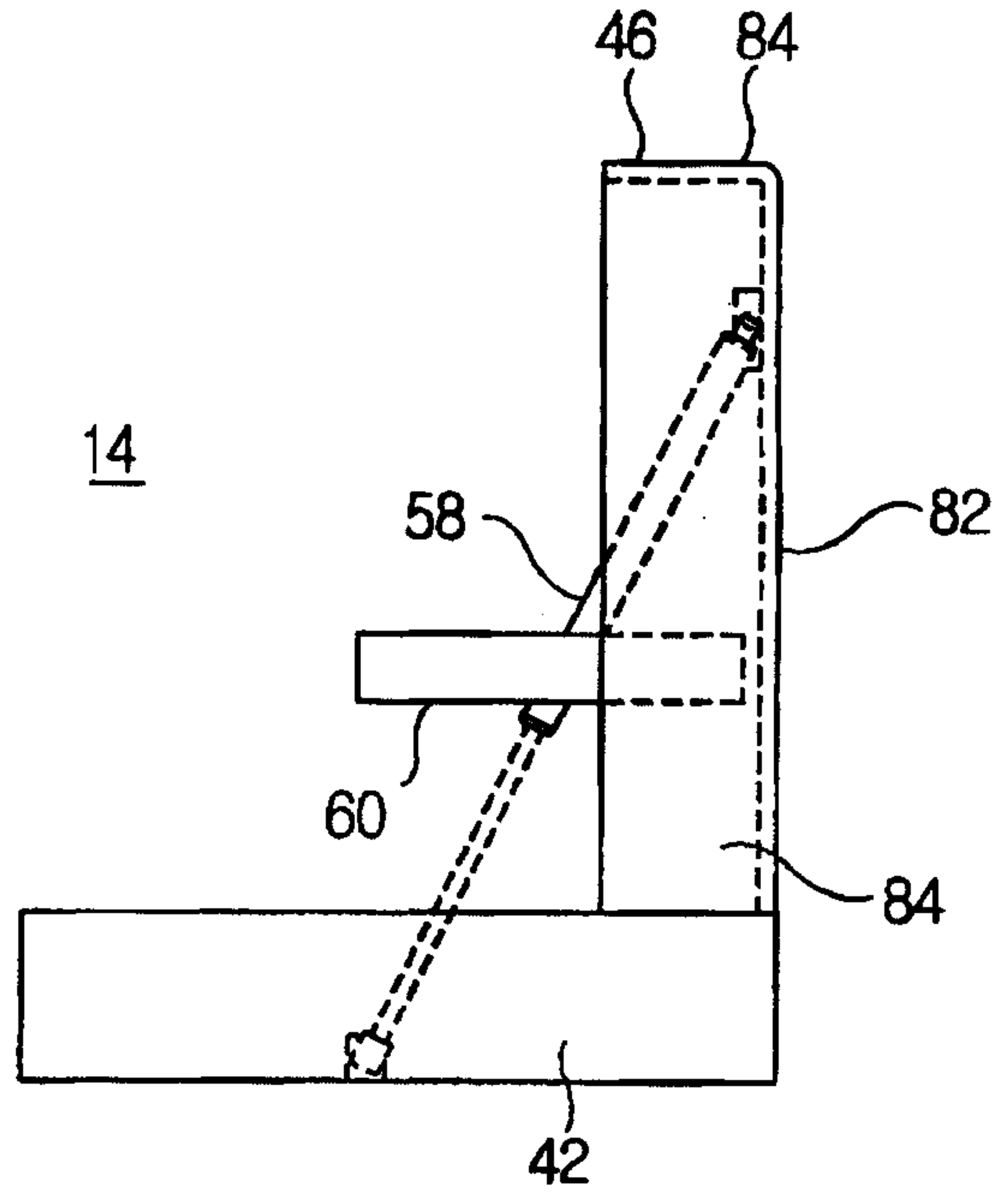
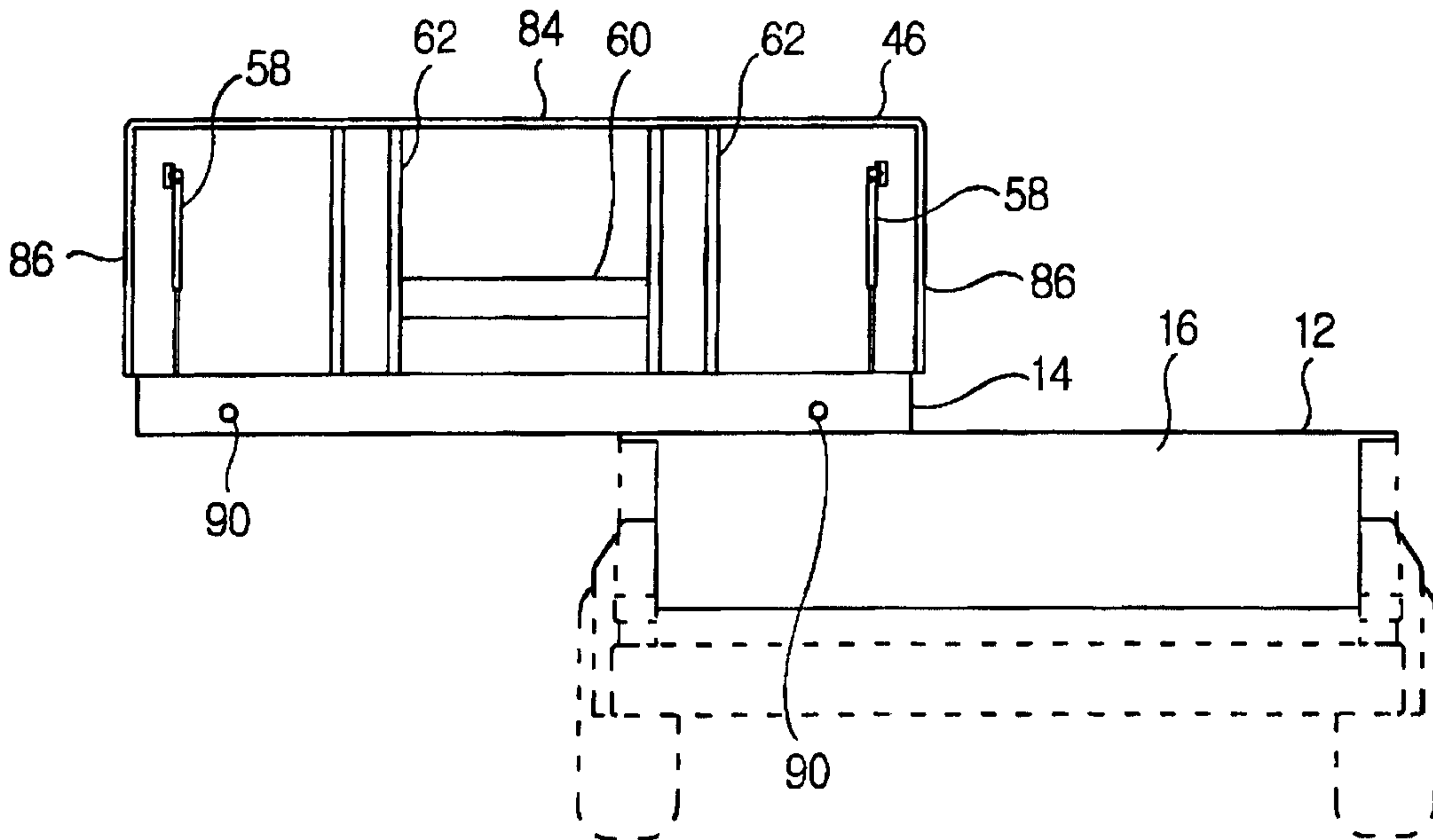

Fig. 15



7/8

Fig. 16

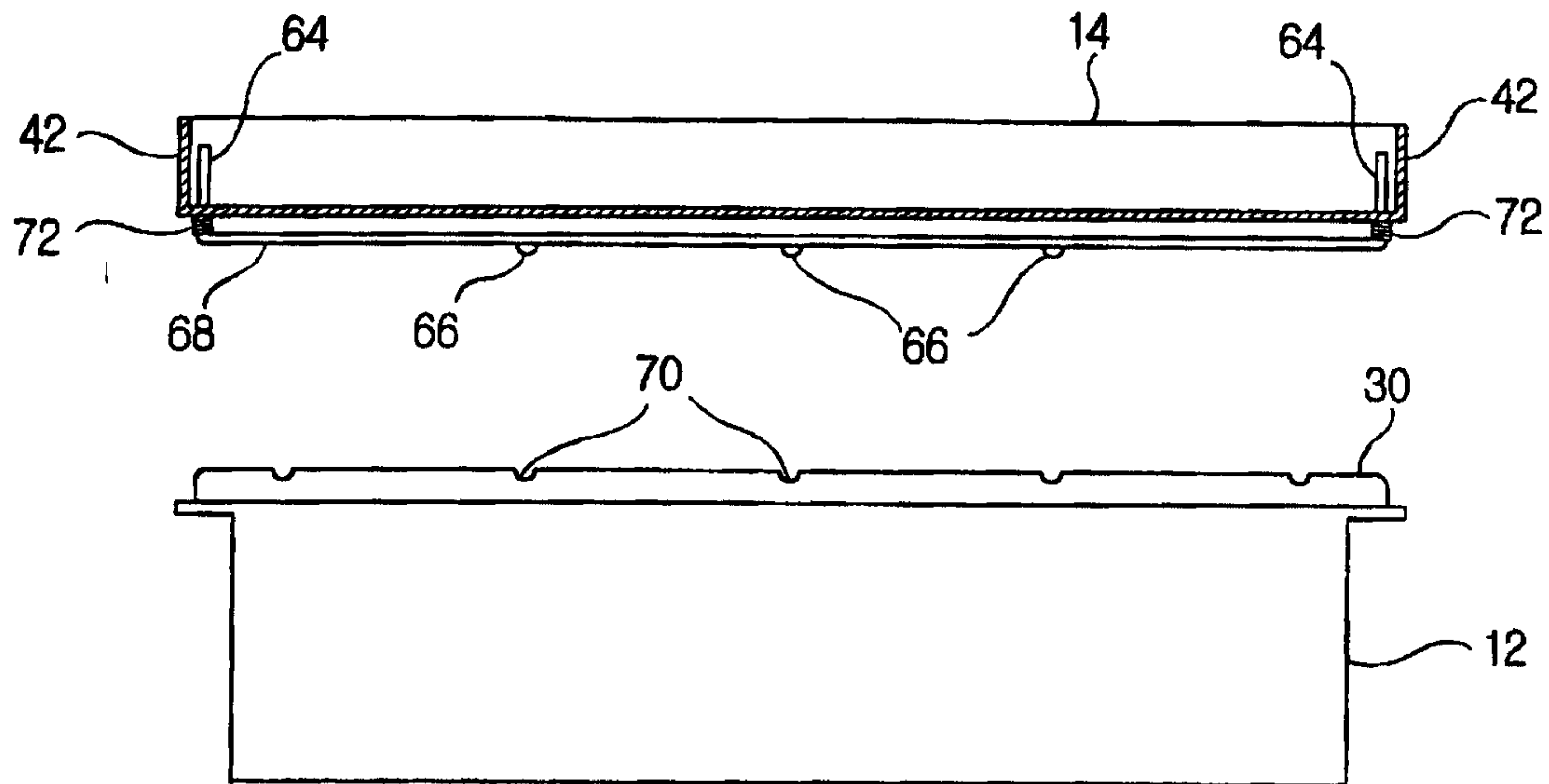

Fig. 17

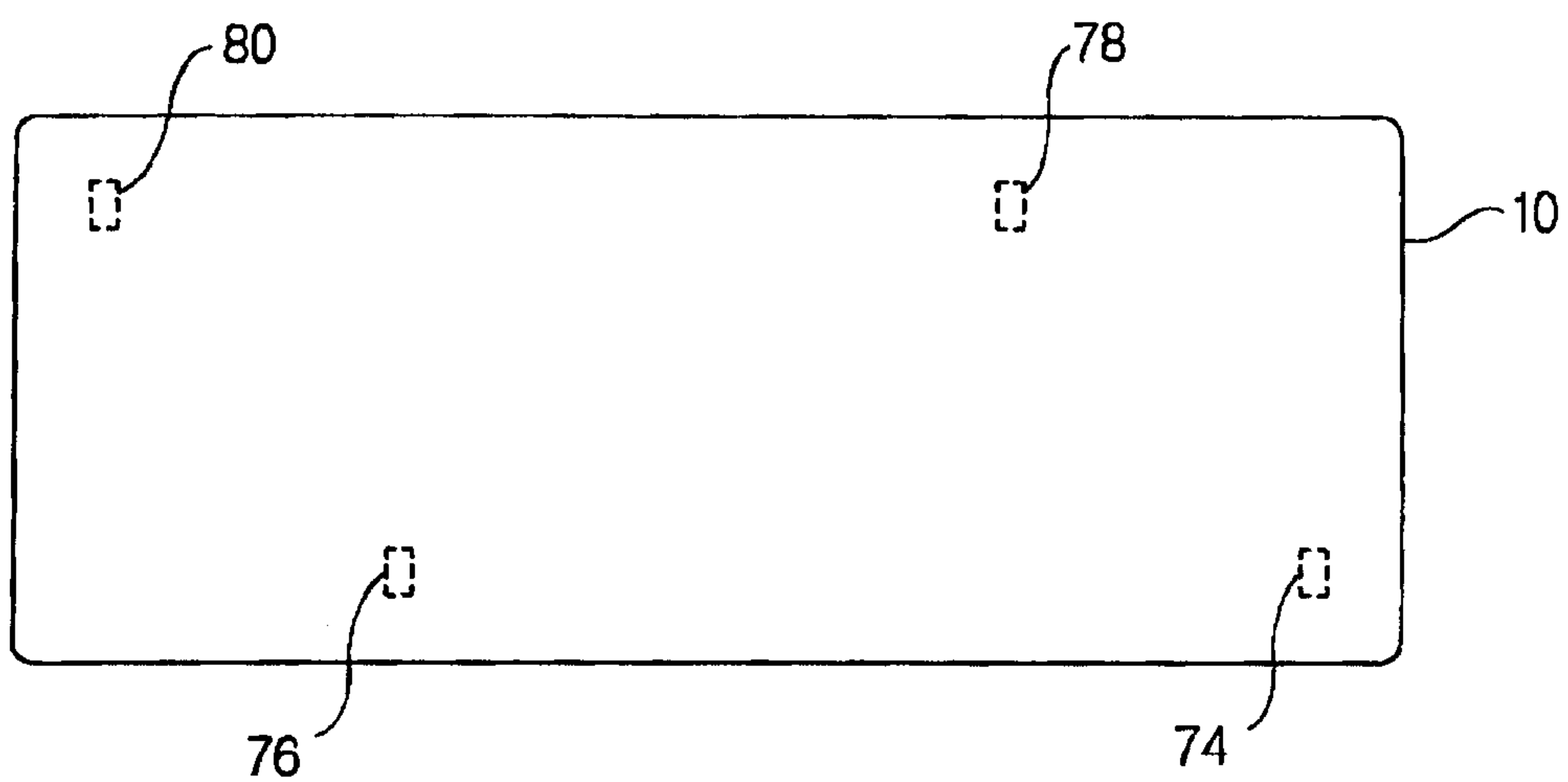

Fig. 18

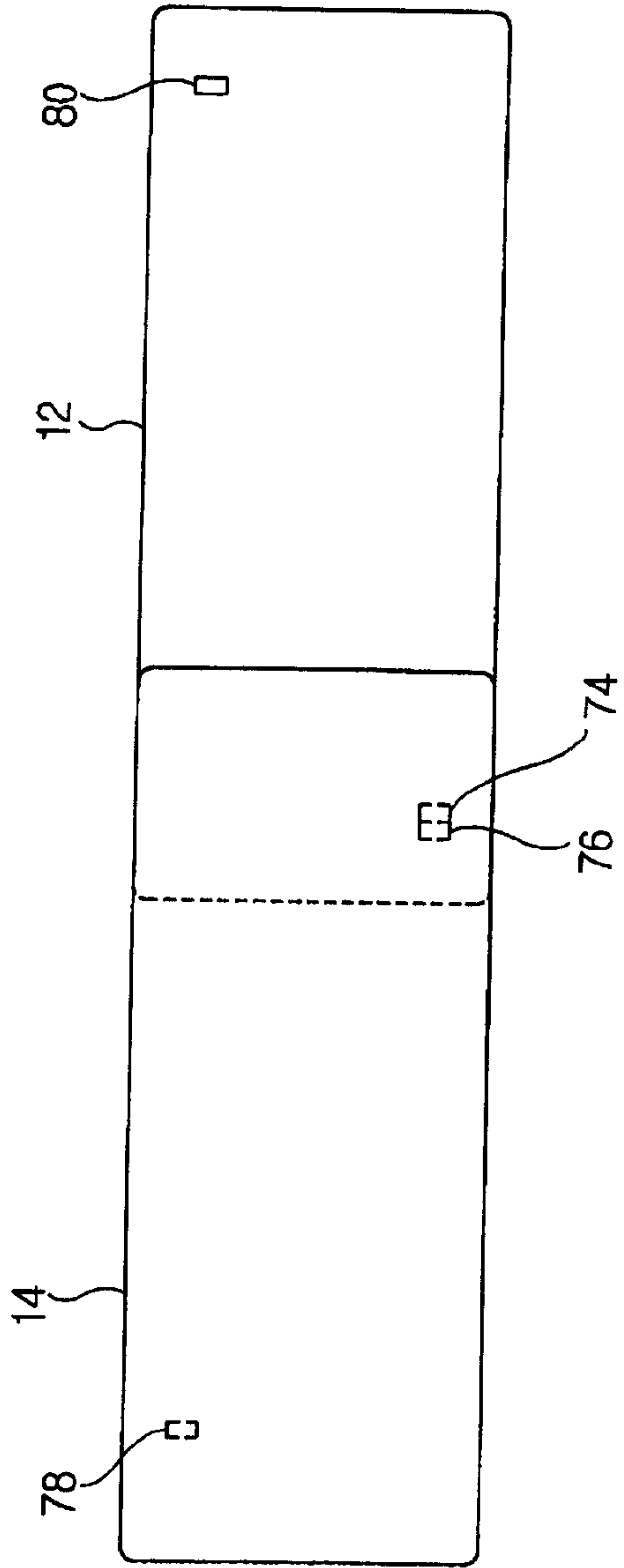

Fig. 19

