

A. BOUCHARD.

Improvement in Machines for the Treatment of Fibrous Plants.

No. 114,400.

Patented May 2, 1871.

Fig. 1.

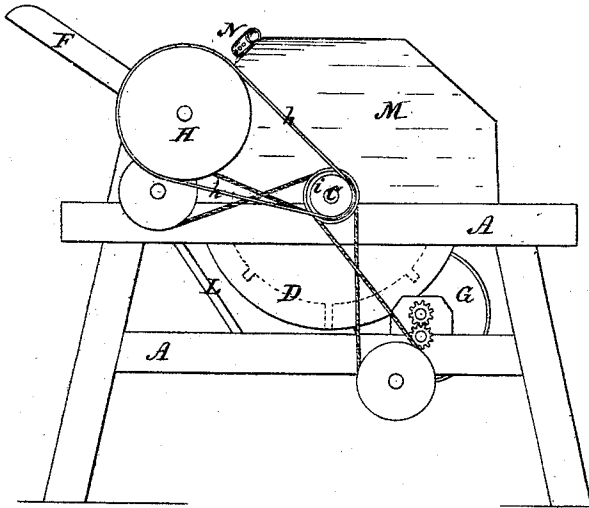

Fig. 2.

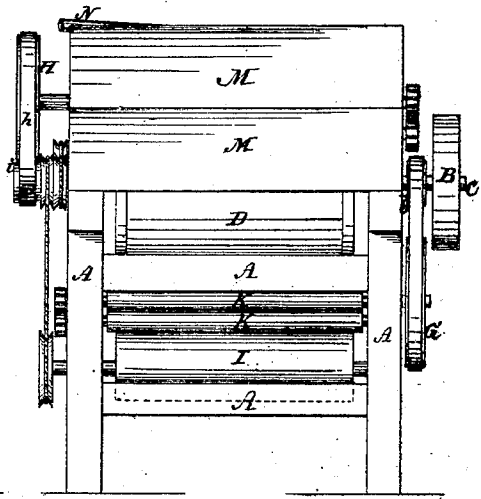
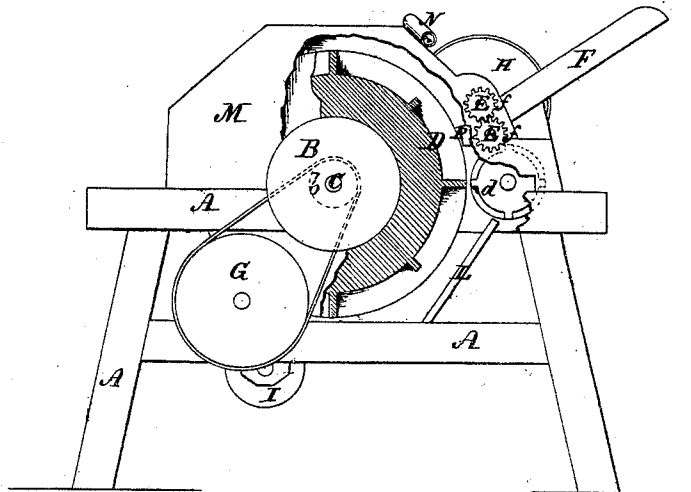

Fig. 3.



Witnesses.

Edmund Masson

H. B. Egner

Inventor.

Adolph Bouchard.

By O. J. Lovell  
His Attorney

A. BOUCHARD.

Improvement in Machines for the Treatment of Fibrous Plants.

No. 114,400.

Patented May 2, 1871.

Fig. 4.

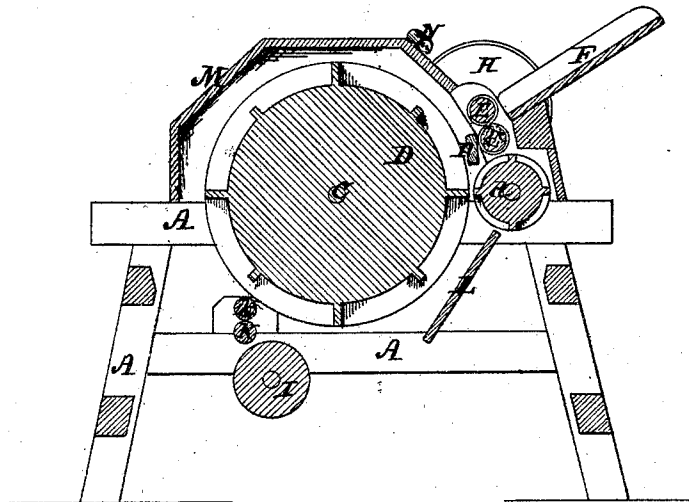

Witnesses

Edmund Masson

A. Moore

Inventor

Adolphe Bouchard

By O. S. Lovell  
His Attorney

# UNITED STATES PATENT OFFICE.

ADOLPH BOUCHARD, OF NEW ORLEANS, LOUISIANA.

IMPROVEMENT IN MACHINES FOR THE TREATMENT OF FIBROUS PLANTS.

Specification forming part of Letters Patent No. **114,400**, dated May 2, 1871.

I, ADOLPH BOUCHARD, of the city of New Orleans, parish of Orleans, and State of Louisiana, have invented a new process for treating the ramie and other plants having fibrous and textile qualities, and for which process I have invented a certain machine, by the use of which I secure all the fibrous portions of plants by separating them from all the other parts, and thus prepare the fibers so as to make them suitable for commerce and manufacture.

I denominate my machine a "ramie-decoricator," although this name but partially defines its manipulations, and do not limit its use alone to this one plant, but intend its application to all similar vegetable products composed in part of fibrous or textile qualities, and which have a bark or covering.

The following is a specification of my invention.

### *Nature and Object.*

My invention relates to the combination of a rotary masher and scraper, with feeding-rollers in such relative positions that the feeding-rollers shall supply the plant to the masher and scraper, which bruise and scrape off the outer bark or covering, and entirely separate the same from the fibrous or textile portions.

It also relates to the combination of a drum with flanges and scrapers, with two rollers placed underneath, so arranged as to draw away the fiber after it has passed through its several operations, and to pass it away from the machine.

### *Description of the Annexed Drawing.*

Figure 1 is a side elevation of the machine. Fig. 2 is a front elevation. Fig. 3 is a side elevation, showing an open sectional view of the main drum with scrapers and flanges. Fig. 4 is a sectional view of the machine.

### *General Description.*

A A A is the frame of the machine, substantially constructed of sufficient strength to resist the vibration when power is applied. B is the driving-pulley attached to the main shaft C, from which motion is communicated to the operating parts. D is a drum, made preferably of iron, covered with sheet metal. This drum should be about two feet in diameter,

and is shown in the drawing as having four flanges and four scrapers; but their number may be varied, as experience may dictate.

E E are two feeding-rollers, connected by finger-pinions *f f*. F is a table, on which the raw material is placed and guided up to the feeding-rollers E E. H is the pulley attached to the feeding-rollers E E, connected by the belt *h h* with the pulley *i i* and the main shaft C. *d d* is a small revolving drum, with small flanges, about four in number, and when used in connection with a large drum, D, of two feet in diameter, they should be about one inch in width, driven by a pulley connected with the main shaft C. This small drum scrapes off and separates the outside covering of the plant.

P is a bar placed between the feeding-rollers E E and drum D, firmly secured to the frame A, with an angular projection of about two inches, forming a lever, by which the plant is held in proper position until caught by the revolving drum, which eventually crushes it into a fibrous mass. I is a roller placed at suitable distance below the drum D, which leads the fiber off after it has been separated and passed through the rollers K K, and from which it is received from the machine in its finished condition.

The roller I is connected by a belt to the pulley *i i* on the main shaft C.

G is the pulley on the rollers K K, which is connected by suitable gearing with the pulley *b b*. L is a panel, attached and firmly secured to the frame A A, so that the plant may be kept near the drum compactly and prevent it being carried round the small drum *d d*. M is the cover of the drum D. N is a pipe or tube, made preferably of india-rubber, with several small perforations on its lower side, to which a stream of water is led, and through which the plant is kept moistened as it passes to and through the feeding-rollers E E, thus removing all the glutinous or other soluble matter, and assisting in the disintegration of the fiber, and enabling it to pass out from the drum D its full length free from all extraneous matter.

### *Operation.*

The plant should be placed upon the table

F, and introduced by the lower end of the stalk through the rollers E E, and then the machine set in motion, the supply being maintained, when the small drum *d d* will do the decortication, the pipe N supply the water, which will partly macerate the plant, and then the mass will be projected by the lever P toward the drum D, which, in its revolutions, will totally disintegrate it and pass it through the rollers K K, fibrated and filamented and deprived of all its gummy and glutinous substance.

*Claim.*

The combination of the drums D and *d*, supported with their flanges and scrapers, as described, the feeding-rollers E E, the lever P, the rollers K K, the roller I, the table F, the cover M, and perforated tube N, for the purpose of filamenting the ramie and similar fibrous plants by decortication and partial maceration, substantially as described.

Witnesses:

A. BOUCHARD.

JAMES J. TINER,  
ALONZO FOLSE.