



(19) **United States**
 (12) **Reissued Patent**
Jeong et al.

(10) **Patent Number:** **US RE50,339 E**
 (45) **Date of Reissued Patent:** **Mar. 18, 2025**

(54) **ELECTRONIC DEVICE FOR SHARING APPLICATION AND CONTROL METHOD THEREOF**

(71) Applicant: **Samsung Electronics Co., Ltd.**, Suwon-si (KR)

(72) Inventors: **Sun-Young Jeong**, Suwon-si (KR); **Kang-Tae Kim**, Seongnam-si (KR); **Chul-Joo Kim**, Suwon-si (KR); **Kun-Woo Baek**, Suwon-si (KR); **Hee-Ran Youn**, Seoul (KR)

(73) Assignee: **Samsung Electronics Co., Ltd.**, Suwon-si (KR)

(21) Appl. No.: **17/887,117**

(22) Filed: **Aug. 12, 2022**

Related U.S. Patent Documents

Reissue of:

(64) Patent No.: **10,893,092**
 Issued: **Jan. 12, 2021**
 Appl. No.: **14/517,092**
 Filed: **Oct. 17, 2014**

(30) **Foreign Application Priority Data**

Oct. 30, 2013 (KR) 10-2013-0130328

(51) **Int. Cl.**
H04L 29/08 (2006.01)
G06F 3/14 (2006.01)
 (Continued)

(52) **U.S. Cl.**
 CPC **G06F 3/1454** (2013.01); **G06F 3/1423** (2013.01); **G06F 9/452** (2018.02); **H04L 67/01** (2022.05); **H04L 67/10** (2013.01); **G09G 5/14** (2013.01); **G09G 2340/0407** (2013.01); **G09G 2354/00** (2013.01); **G09G 2358/00** (2013.01);
 (Continued)

(58) **Field of Classification Search**

CPC G06F 3/1454; G06F 9/452; G06F 3/1423; H04L 67/10; H04L 67/01; G09G 5/14; G09G 2370/04; G09G 2340/0407; G09G 2358/00; G09G 2370/16; G09G 2354/00
 See application file for complete search history.

(56) **References Cited**

U.S. PATENT DOCUMENTS

6,686,852 B1 2/2004 Guo
 8,271,907 B2 9/2012 Kim et al.
 (Continued)

FOREIGN PATENT DOCUMENTS

CN 1344989 A 4/2002
 CN 1458576 A 11/2003
 (Continued)

OTHER PUBLICATIONS

Extended European Search Report dated Apr. 19, 2022, issued in European Patent Application No. 22153064.5.
 (Continued)

Primary Examiner — William H. Wood

(74) *Attorney, Agent, or Firm* — Jefferson IP Law, LLP

(57) **ABSTRACT**

A control method of a host electronic device communicating with a client electronic device is provided. The control method includes forming a connection with the client electronic device, determining an application to be shared with the client electronic device, generating shared data for the application to be shared, and transmitting the shared data to the client electronic device.

28 Claims, 23 Drawing Sheets

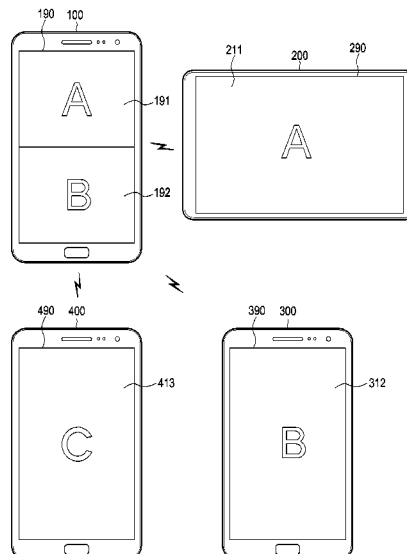

(51)	Int. Cl. G06F 9/451 (2018.01) G09G 5/14 (2006.01) H04L 29/06 (2006.01) H04L 67/01 (2022.01) H04L 67/10 (2022.01)	2013/0283193 A1* 10/2013 Griffin G06F 3/1446 715/761 2014/0040803 A1* 2/2014 Briand G06F 3/0486 715/769 2014/0089385 A1* 3/2014 Thayer H04N 21/4402 709/203 2014/0170978 A1* 6/2014 Wolman G06F 9/54 455/41.2 2014/0245194 A1* 8/2014 Wright G06F 9/452 715/761 2014/0351344 A1 11/2014 Wu et al. 2015/0200998 A1* 7/2015 Gu H04L 67/131 709/208
(52)	U.S. Cl. CPC G09G 2370/04 (2013.01); G09G 2370/16 (2013.01)	
(56)	References Cited	

U.S. PATENT DOCUMENTS

9,077,811 B2*	7/2015	Liang	H04M 1/72412
2003/0076362 A1	4/2003	Terada	
2004/0056903 A1	3/2004	Sakai	
2005/0235220 A1	10/2005	Duperrouzel et al.	
2007/0192726 A1	8/2007	Kim et al.	
2008/0172609 A1	7/2008	Rytivaara	
2008/0214239 A1	9/2008	Hashimoto et al.	
2008/0320396 A1	12/2008	Mizrachi et al.	
2009/0307631 A1	12/2009	Kim et al.	
2009/0322690 A1	12/2009	Hiltunen et al.	
2010/0062811 A1	3/2010	Park et al.	
2010/0088634 A1	4/2010	Tsuruta et al.	
2010/0138780 A1	6/2010	Marano et al.	
2010/0169791 A1	7/2010	Pering et al.	
2010/0214278 A1	8/2010	Miura	
2010/0248788 A1	9/2010	Yook et al.	
2010/0262673 A1*	10/2010	Chang	G06F 3/1454 709/217
2010/0312817 A1	12/2010	Steakley	
2011/0066971 A1*	3/2011	Forutanpour	G06F 9/451 715/788
2011/0106954 A1	5/2011	Chatterjee et al.	
2012/0054640 A1	3/2012	Nancke-Krogh	
2012/0088548 A1	4/2012	Yun et al.	
2012/0159334 A1	6/2012	Messerly et al.	
2012/0159472 A1*	6/2012	Hong	H04W 4/21 717/178
2012/0176322 A1	7/2012	Karmi et al.	
2012/0303476 A1	11/2012	Krzyzanowski et al.	
2013/0219303 A1	8/2013	Eriksson et al.	
2013/0278484 A1*	10/2013	Hwang	G06F 3/1423 345/2.3

FOREIGN PATENT DOCUMENTS

CN	101352057 A	1/2009
CN	102 638 586 A	8/2012
JP	10-260784 A	9/1998
JP	2004-046796 A	2/2004
JP	2006-073015 A	3/2006
JP	2006-115213 A	4/2006
JP	2008-117181 A	5/2008
JP	2008-134348 A	6/2008
KR	10-0478920 B1	3/2005
KR	10-2006-0039503 A	5/2006
KR	10-0650257 B1	11/2006
KR	10-0652626 B1	12/2006
KR	10-0700171 B1	3/2007
KR	10-2008-0018396 A	2/2008
KR	2008/090902 A1	7/2008
KR	10-2009-0016044 A	2/2009
KR	10-0900295 B1	5/2009
KR	10-2010-0030968 A	3/2010
KR	10-2010-0053823 A	5/2010
KR	10-2010-0080394 A	7/2010
WO	2008/090902 A1	7/2008
WO	2009/017175 A1	2/2009
WO	2009/028892 A2	3/2009

OTHER PUBLICATIONS

Examination report dated Sep. 28, 2018, issued in the European application No. 14 190 689.1.

* cited by examiner

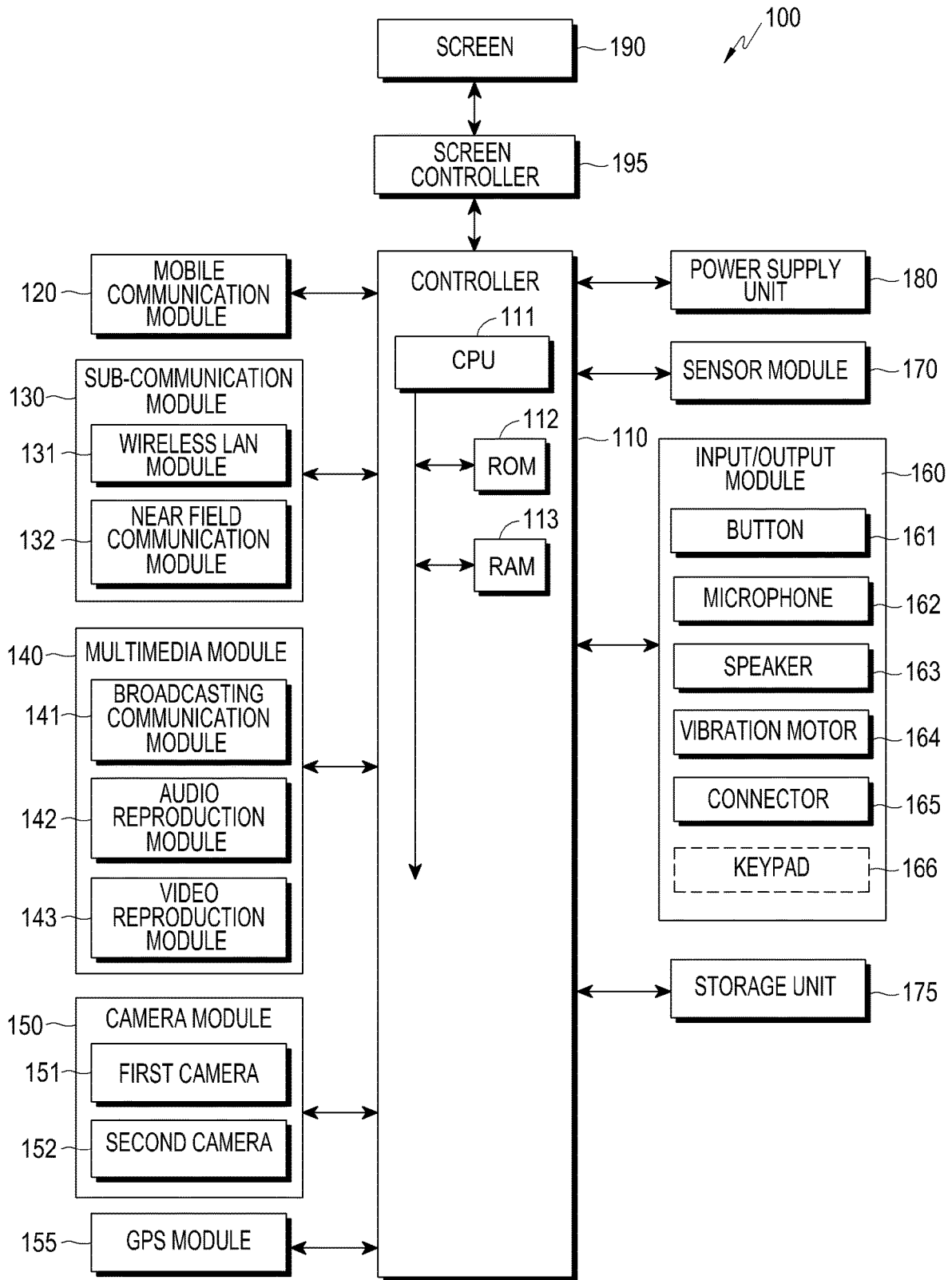

FIG. 1

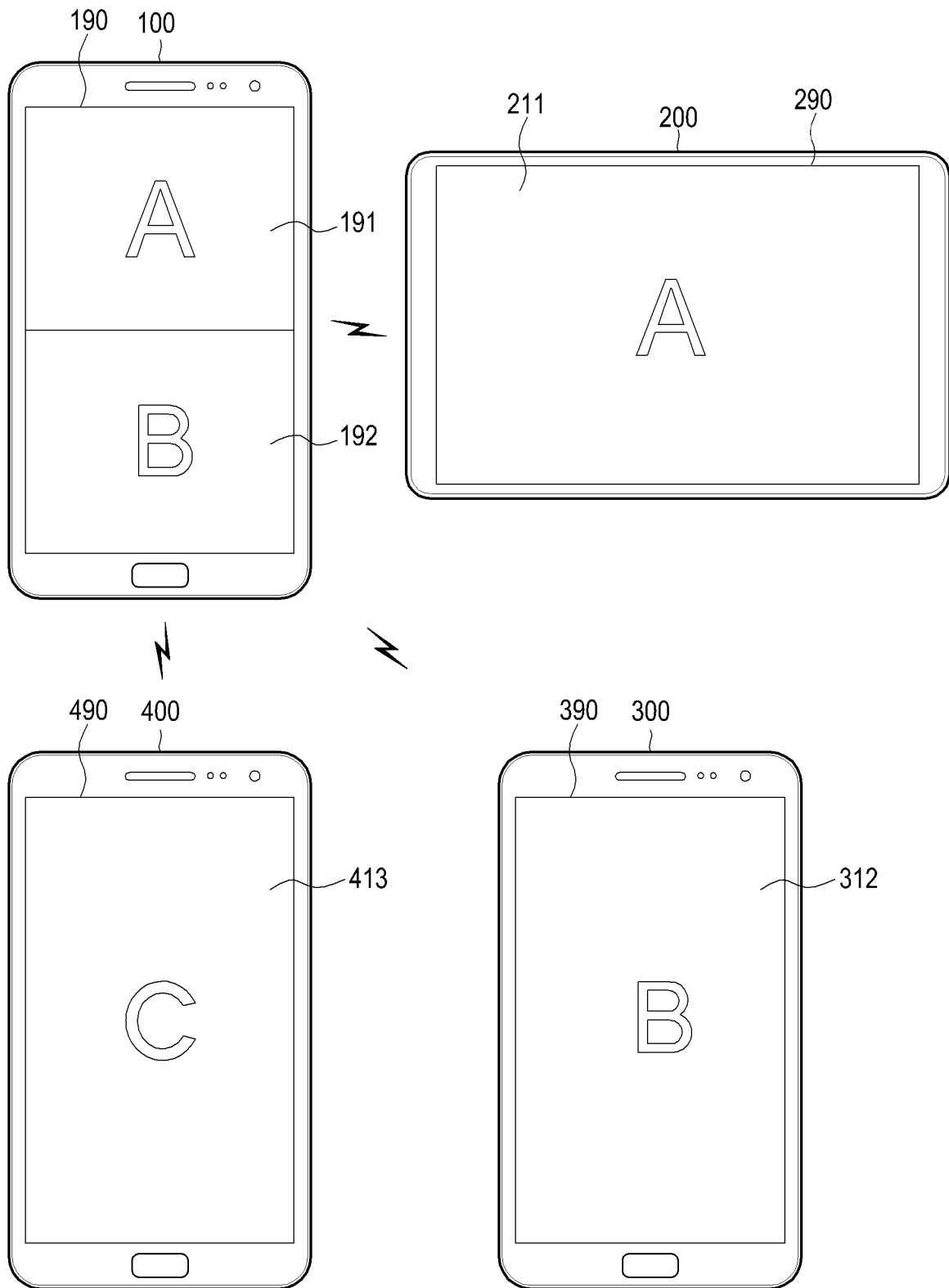

FIG. 2

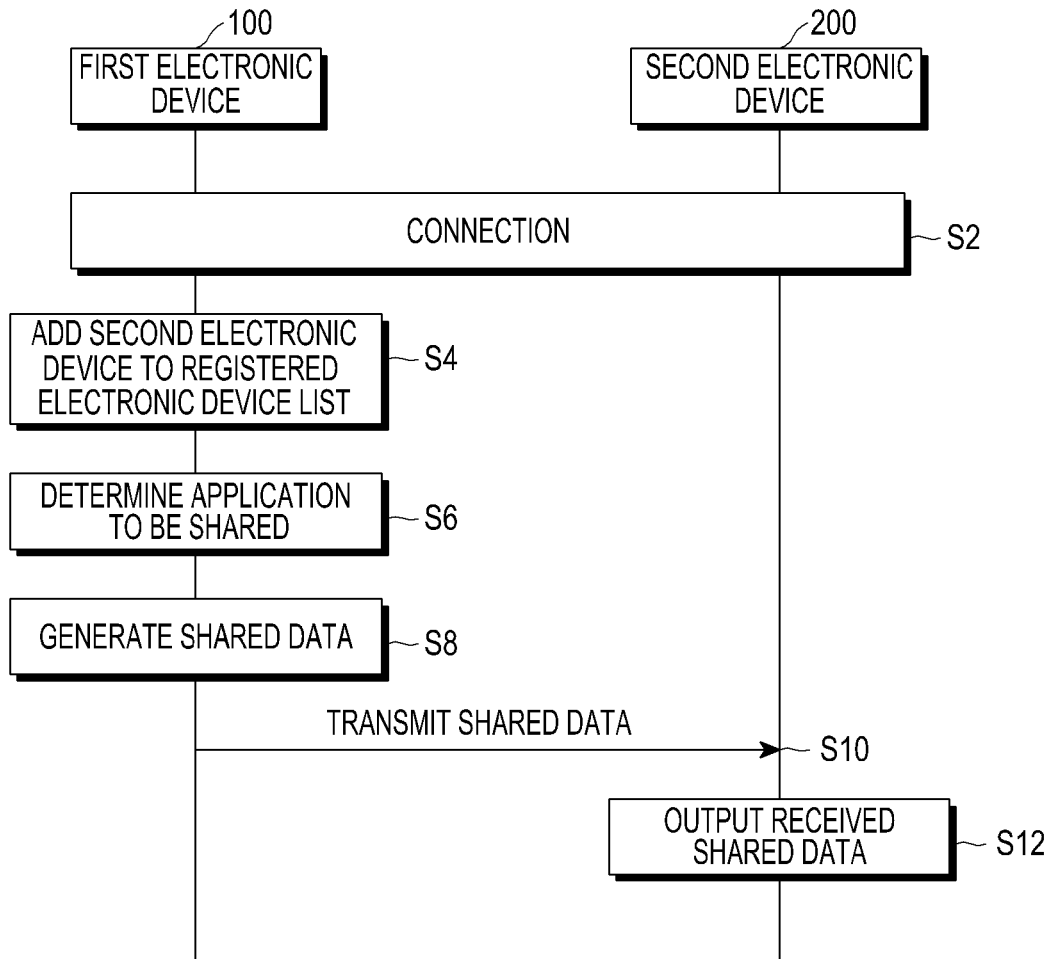

FIG.3

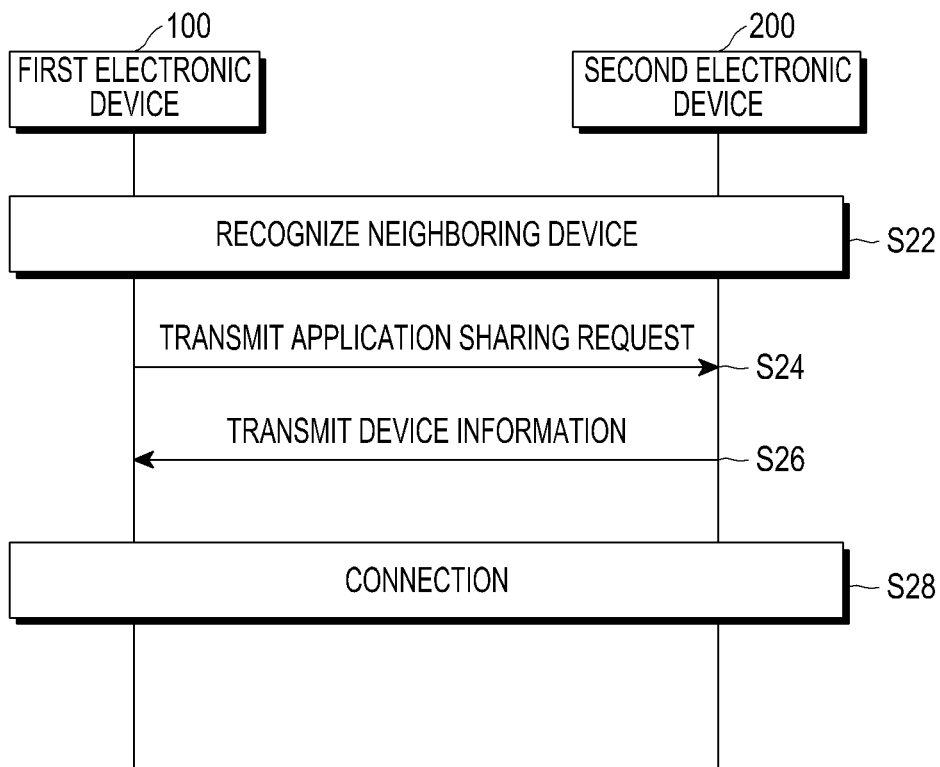

FIG. 4

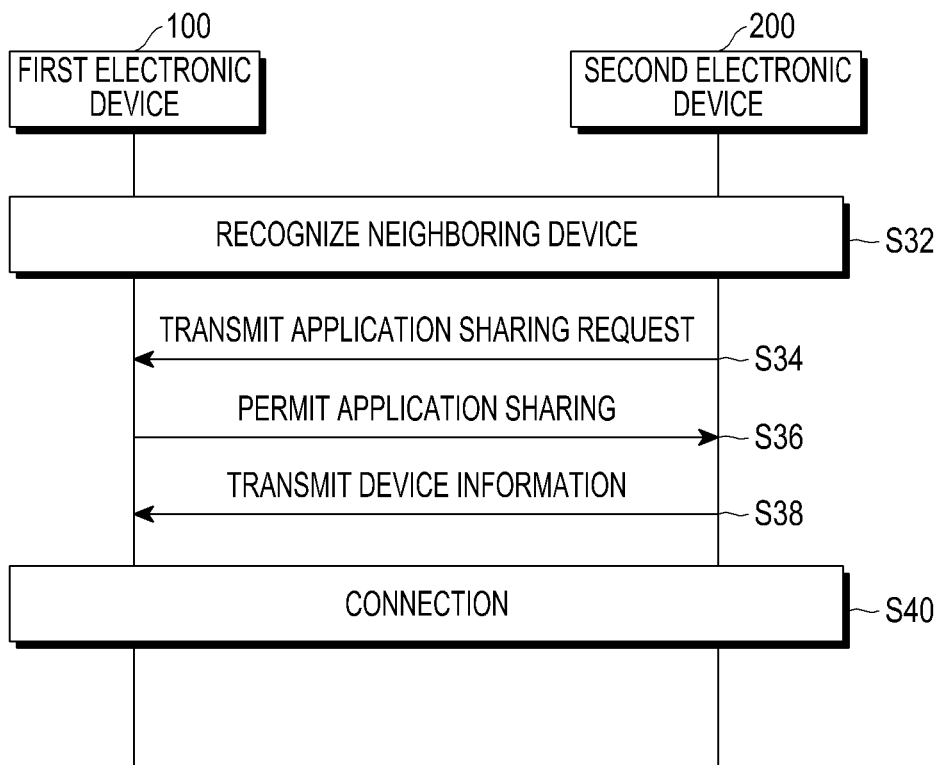

FIG. 5

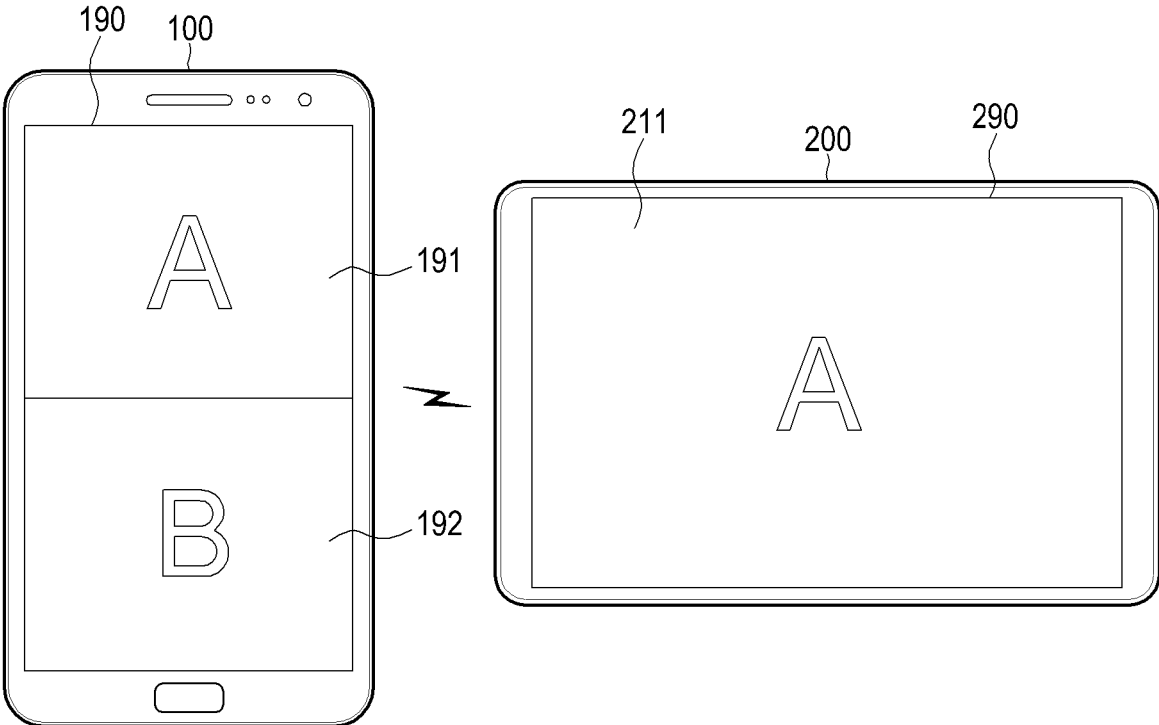

FIG.6A

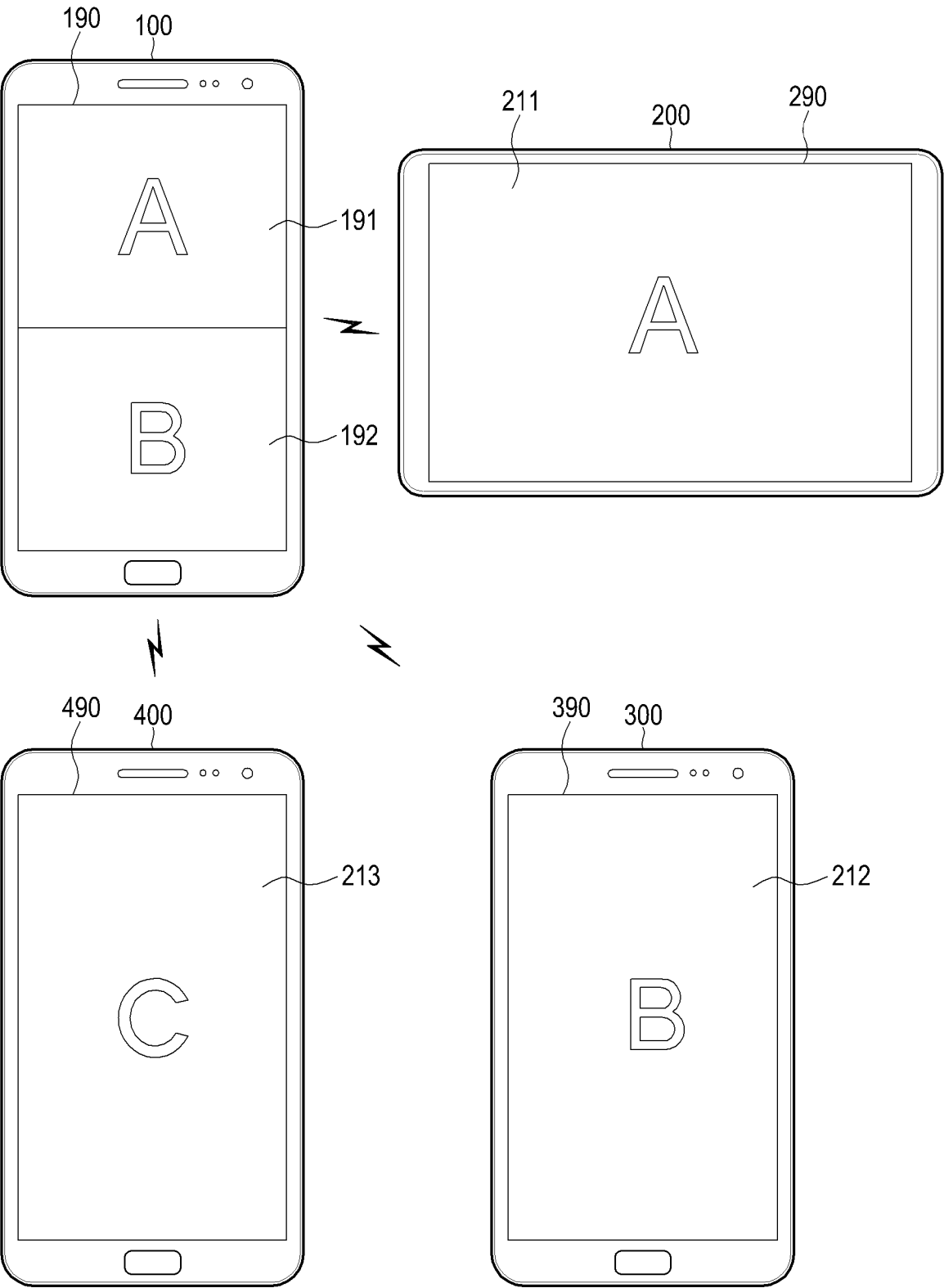

FIG.6B

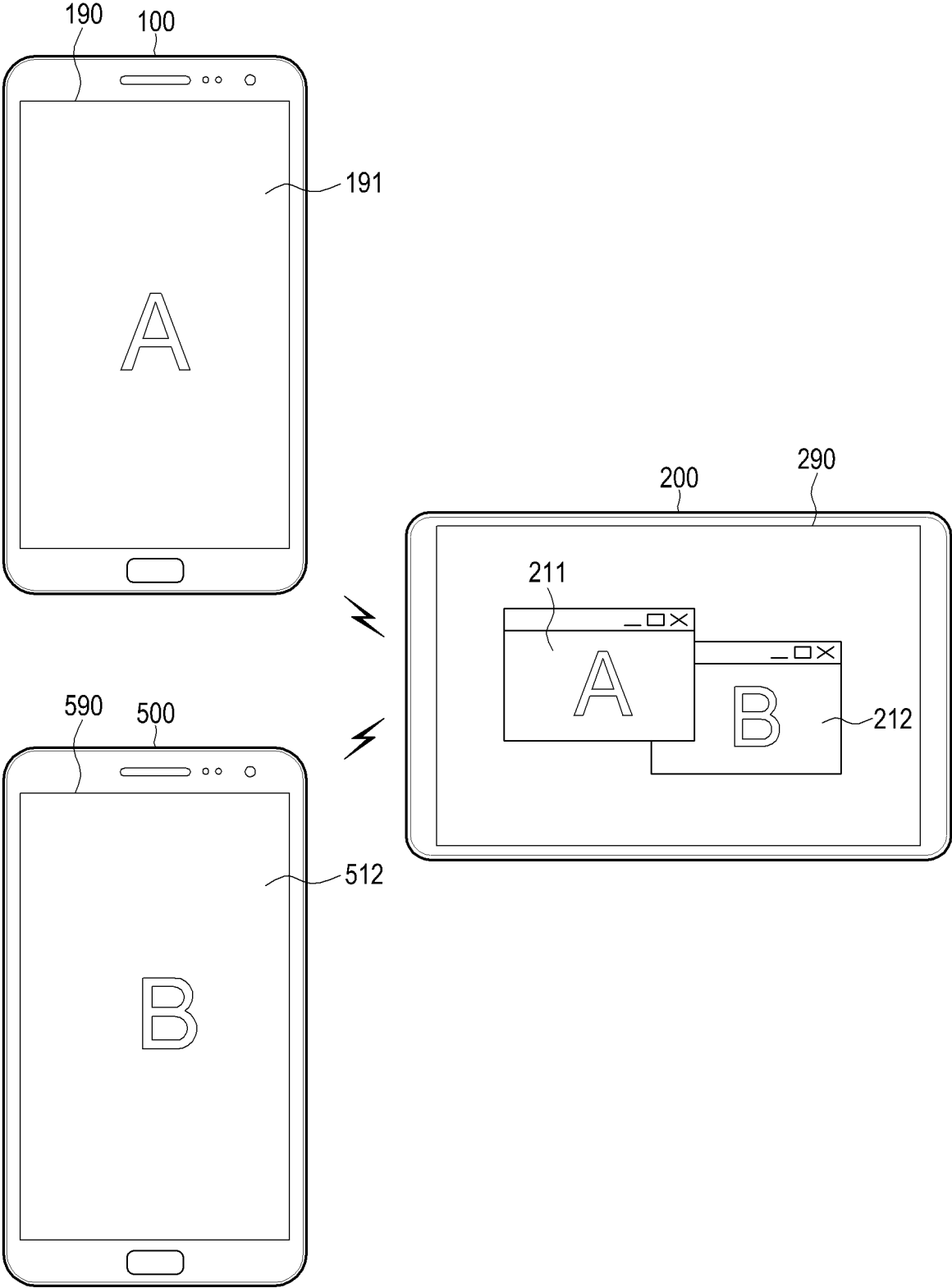

FIG.6C

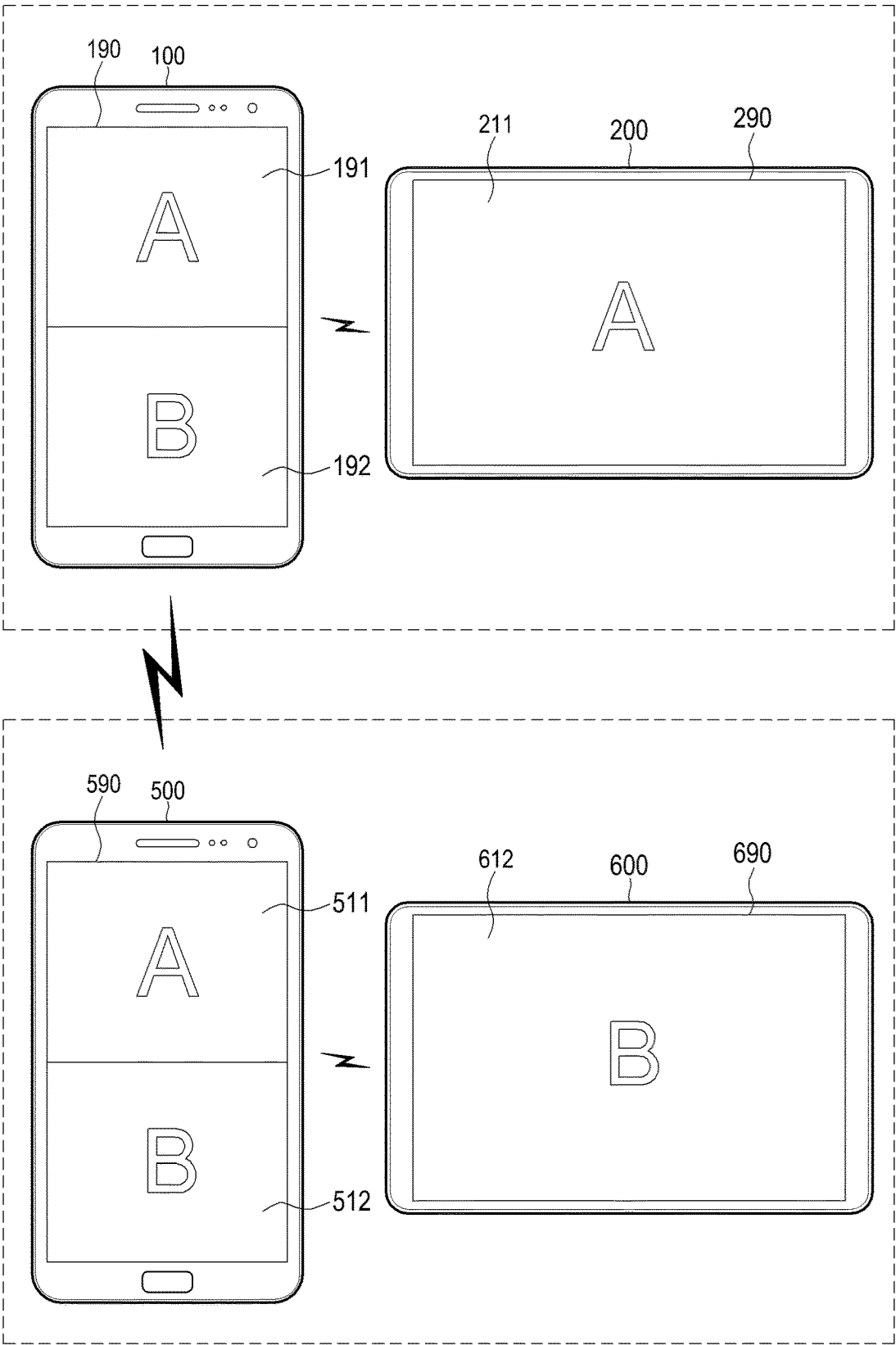

FIG.6D

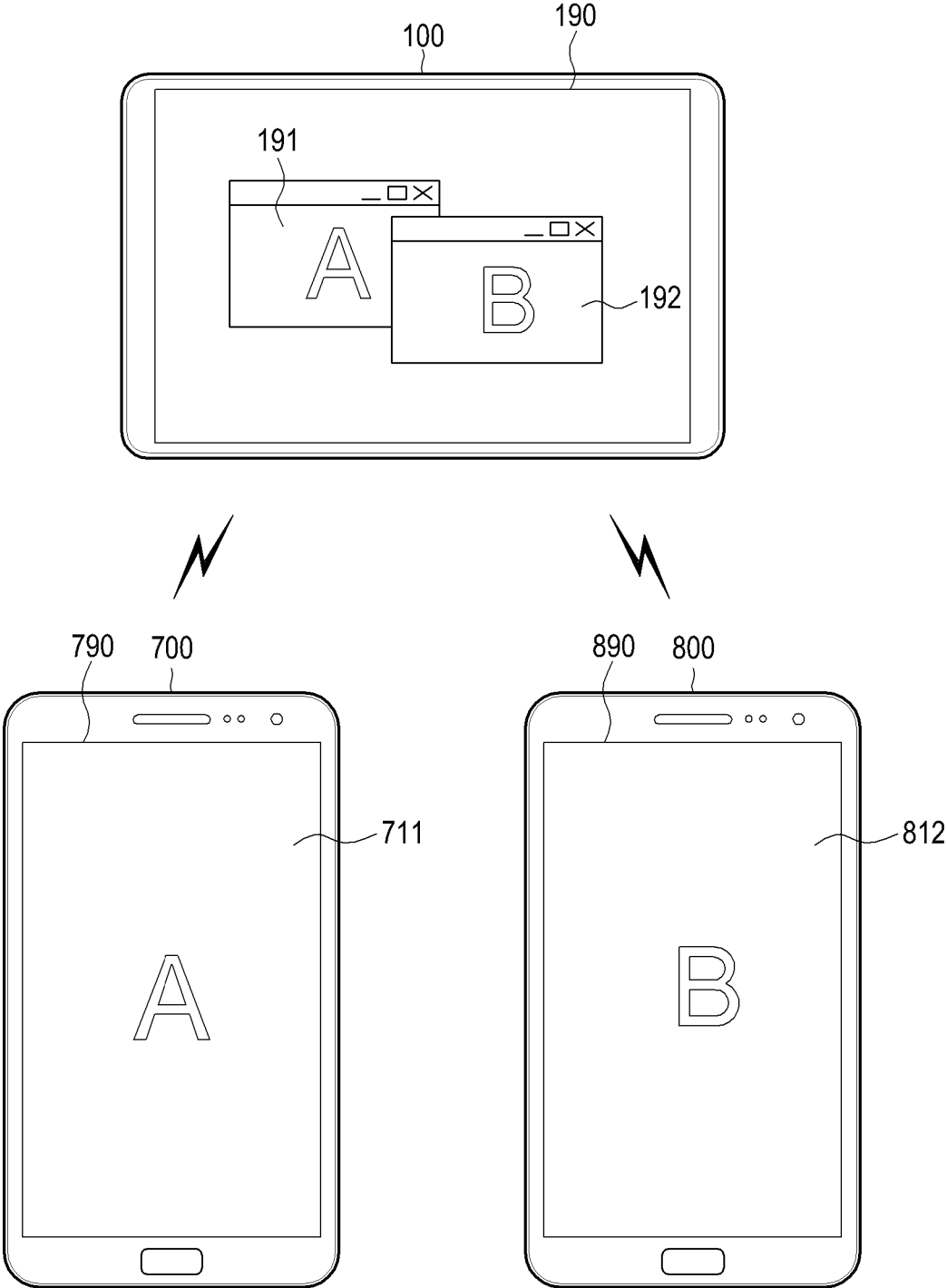

FIG.6E

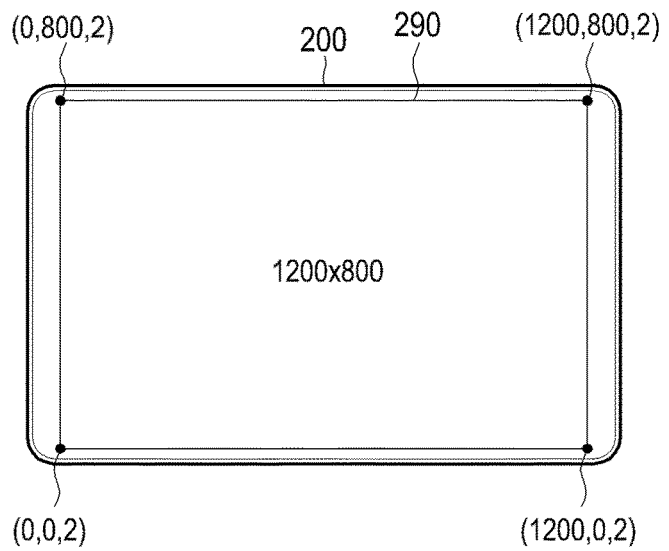
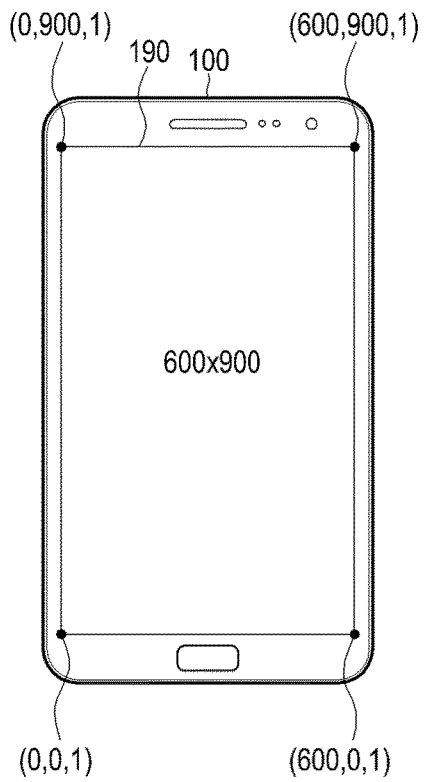

FIG. 7A

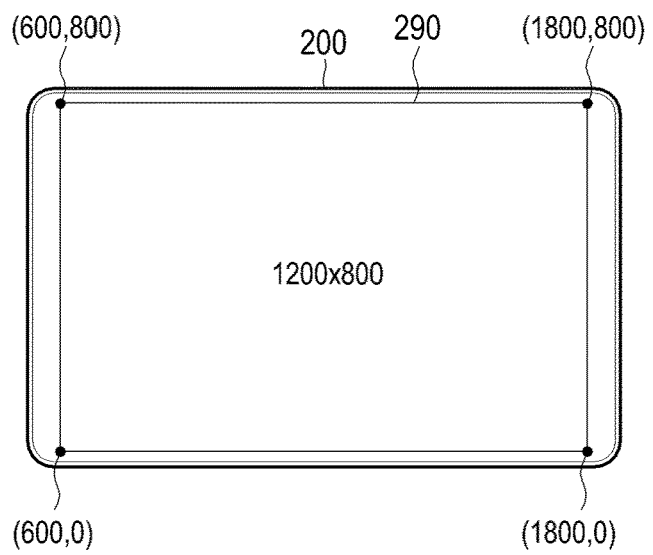
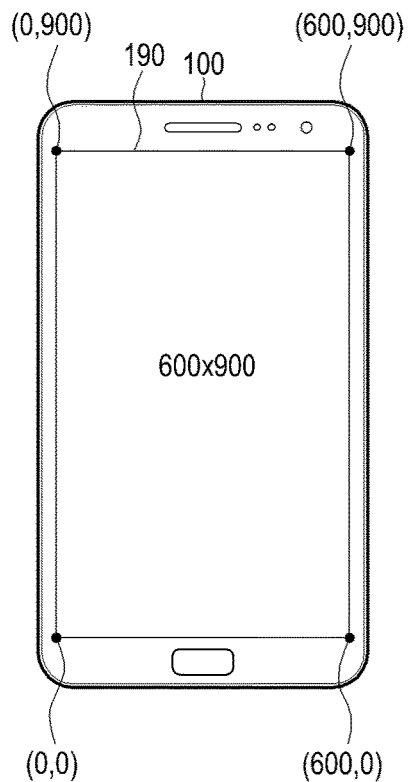

FIG. 7B

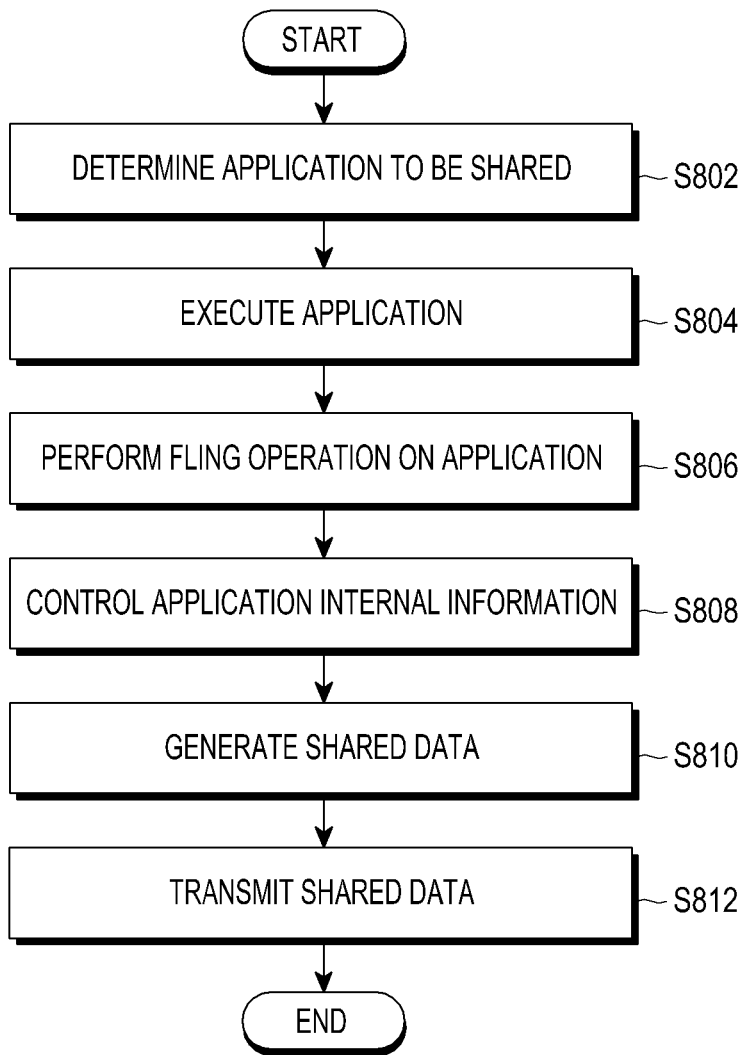

FIG.8

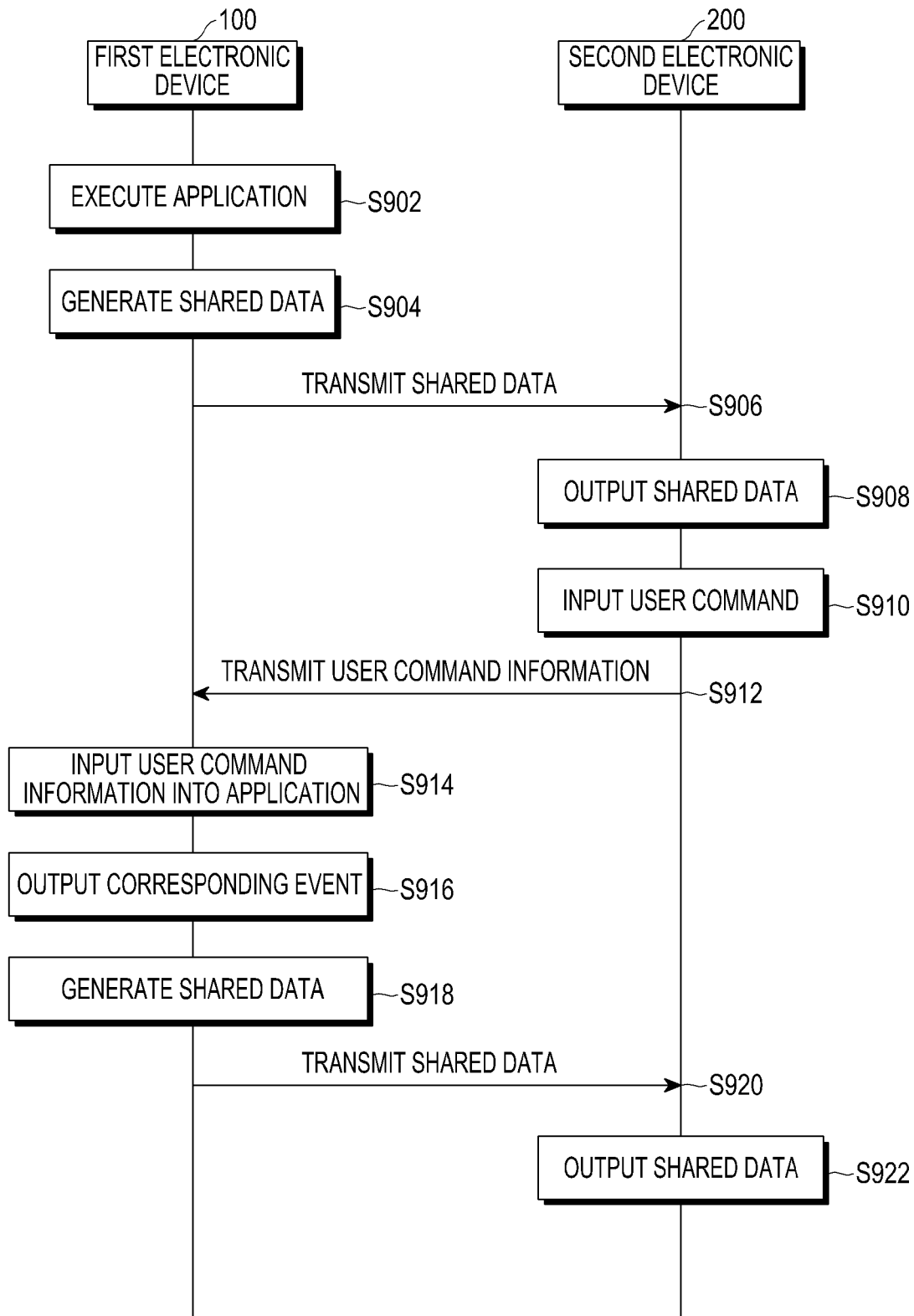

FIG. 9

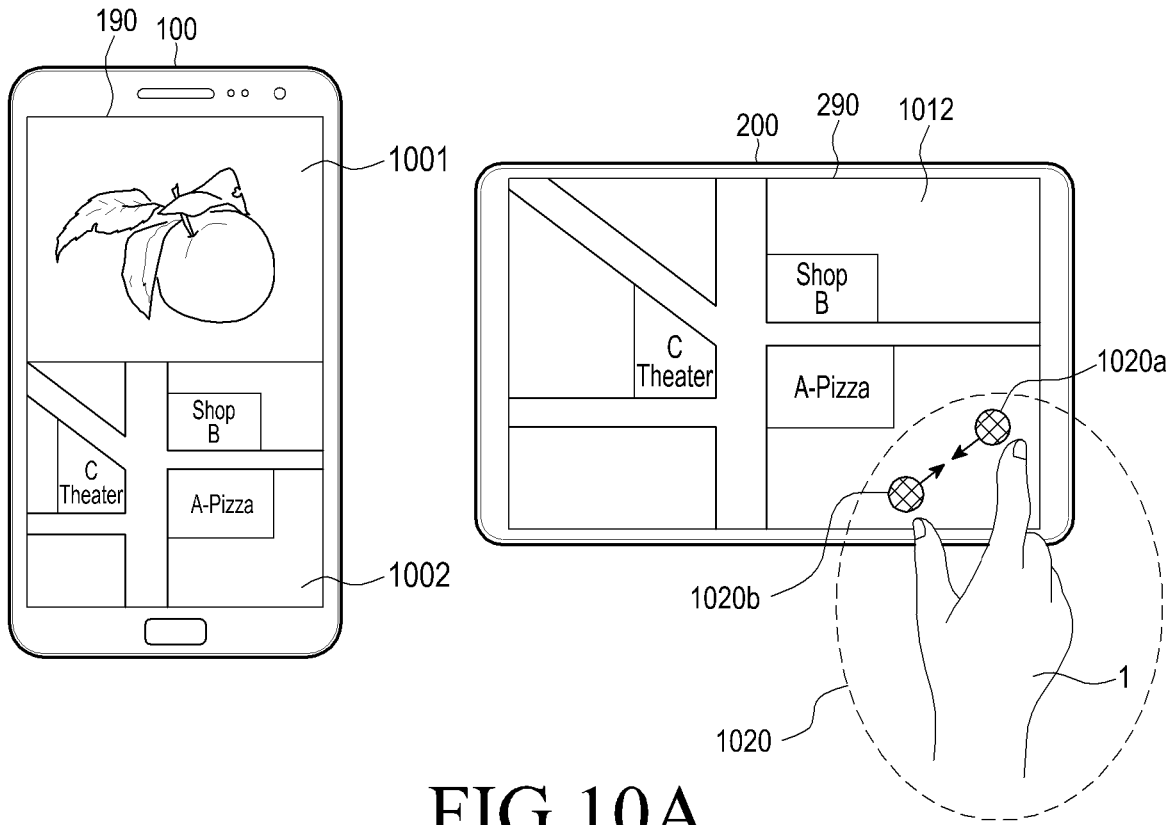

FIG. 10A

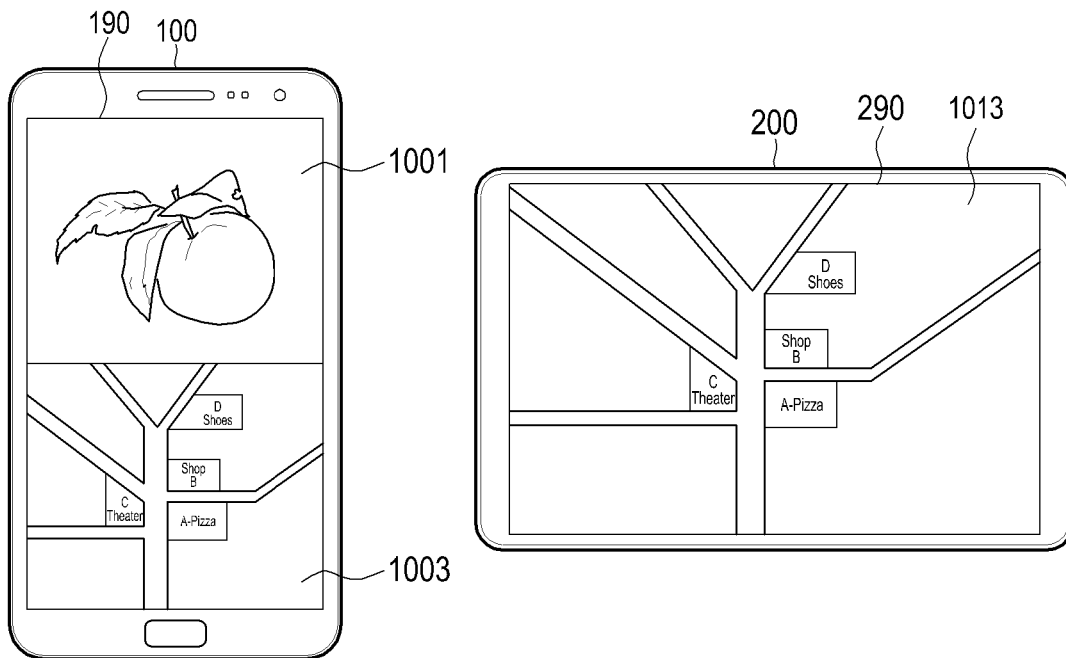

FIG. 10B

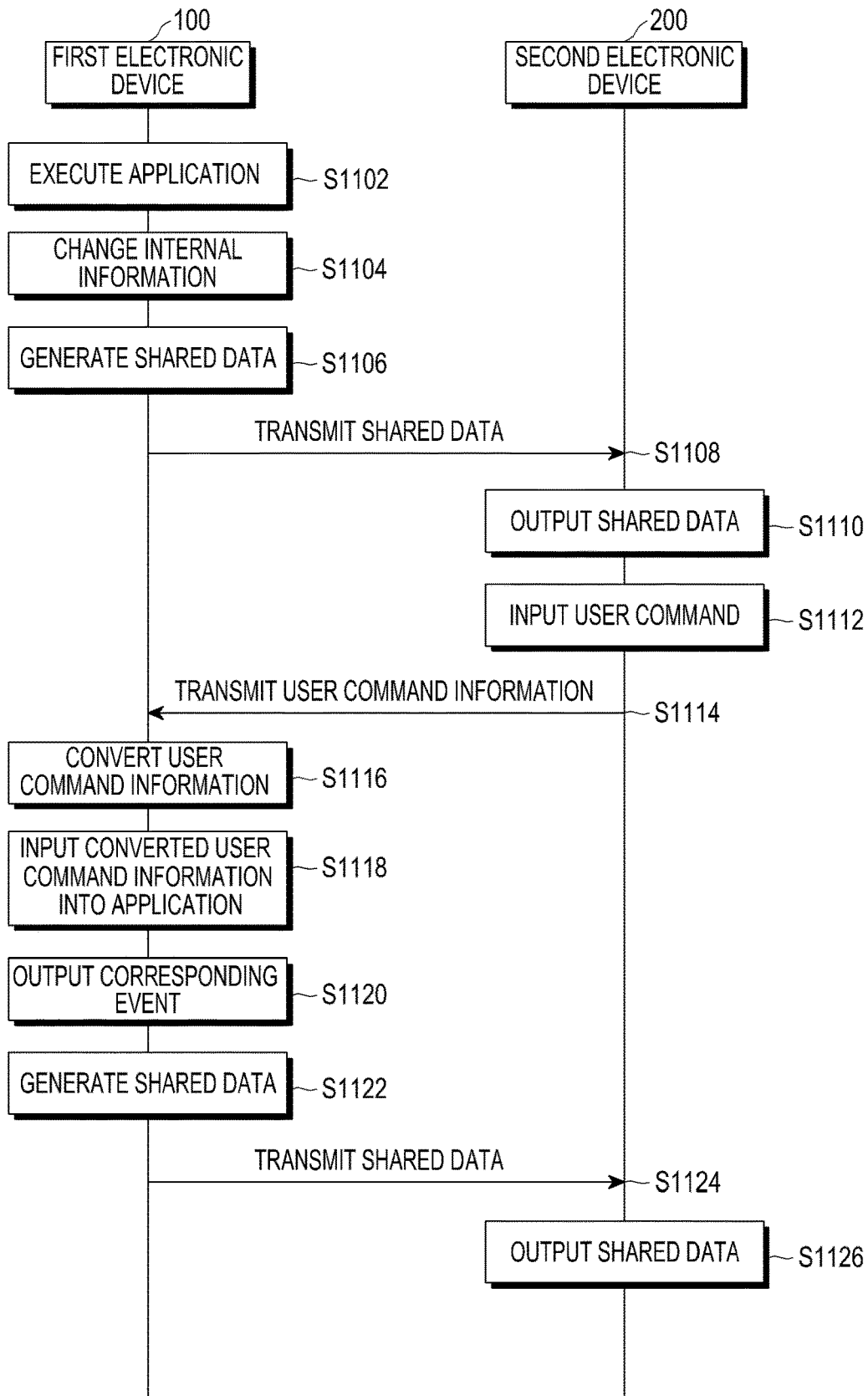

FIG.11

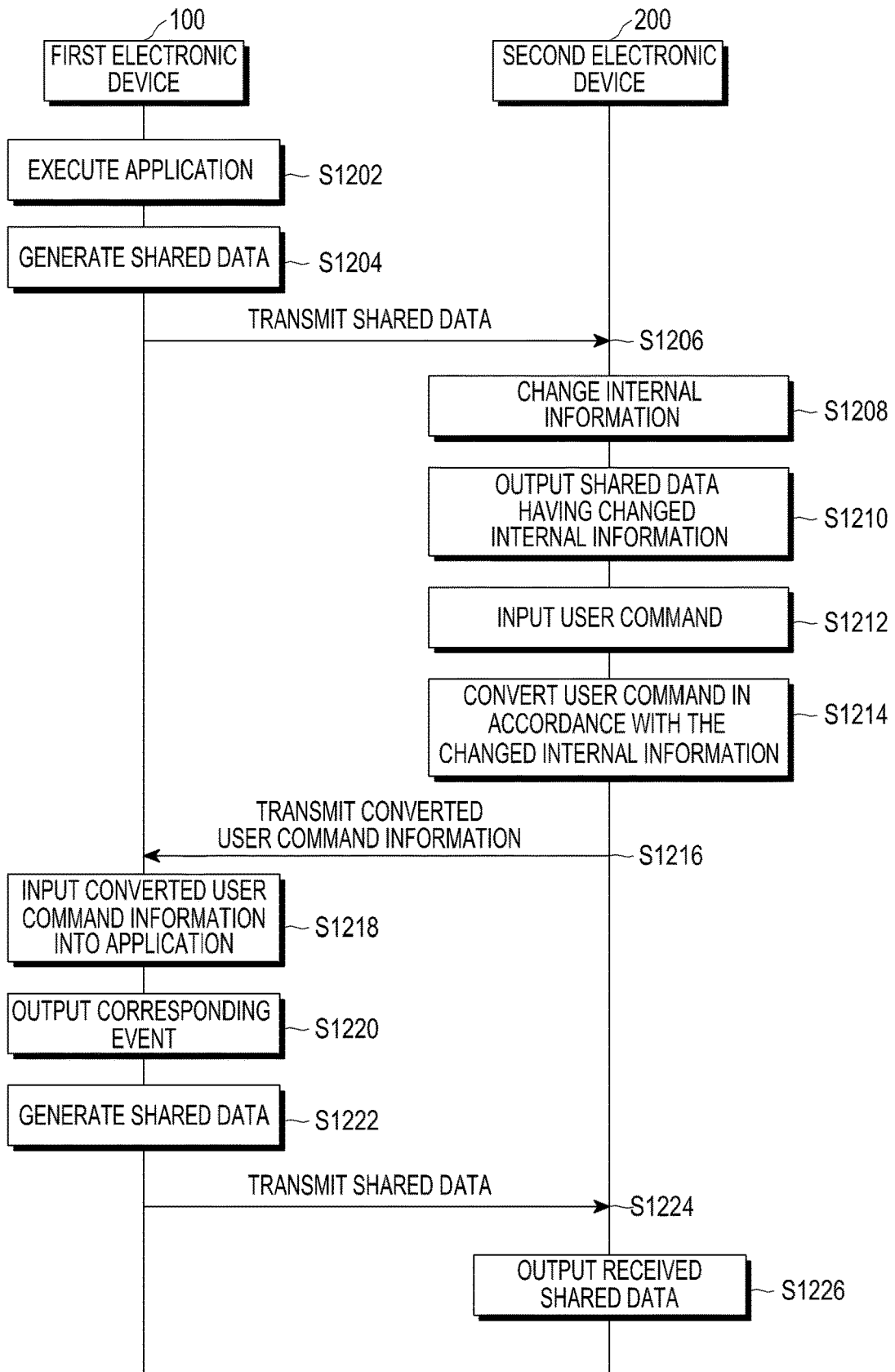

FIG. 12

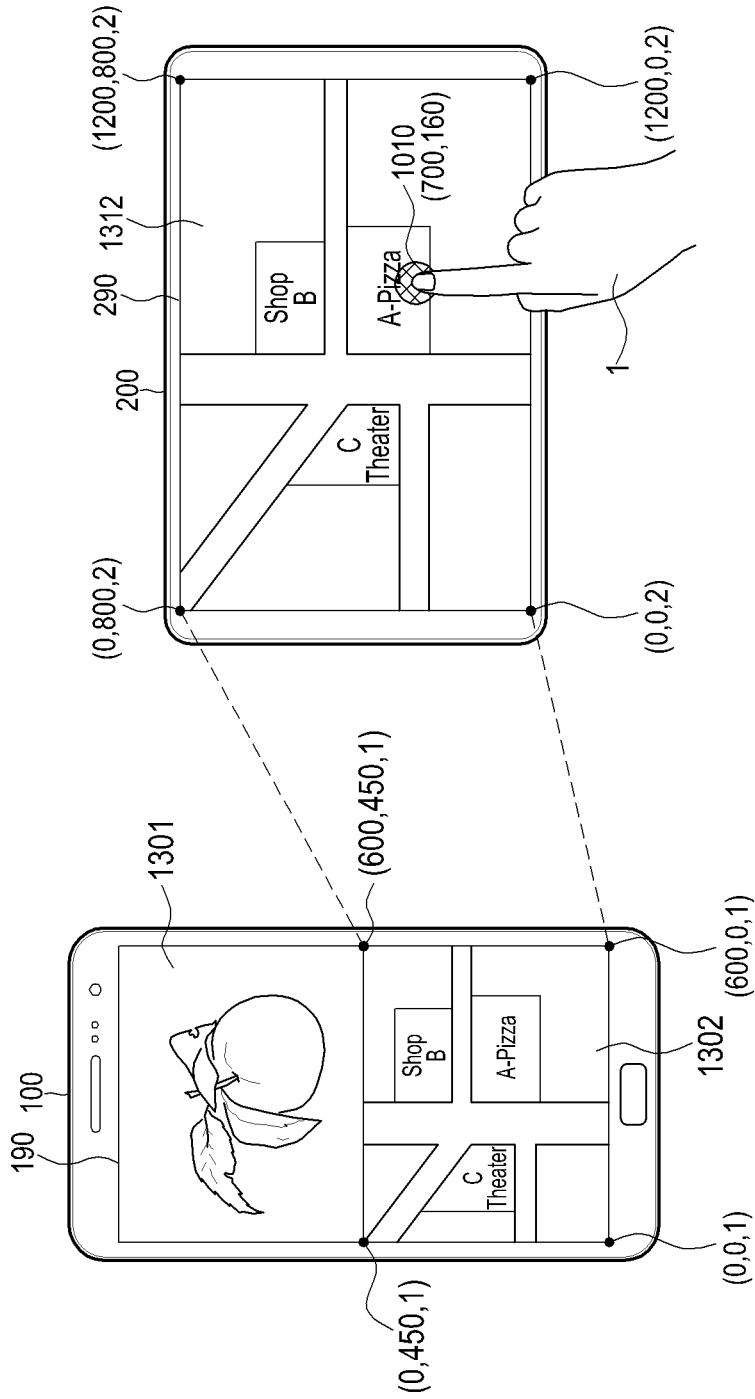

FIG.13A

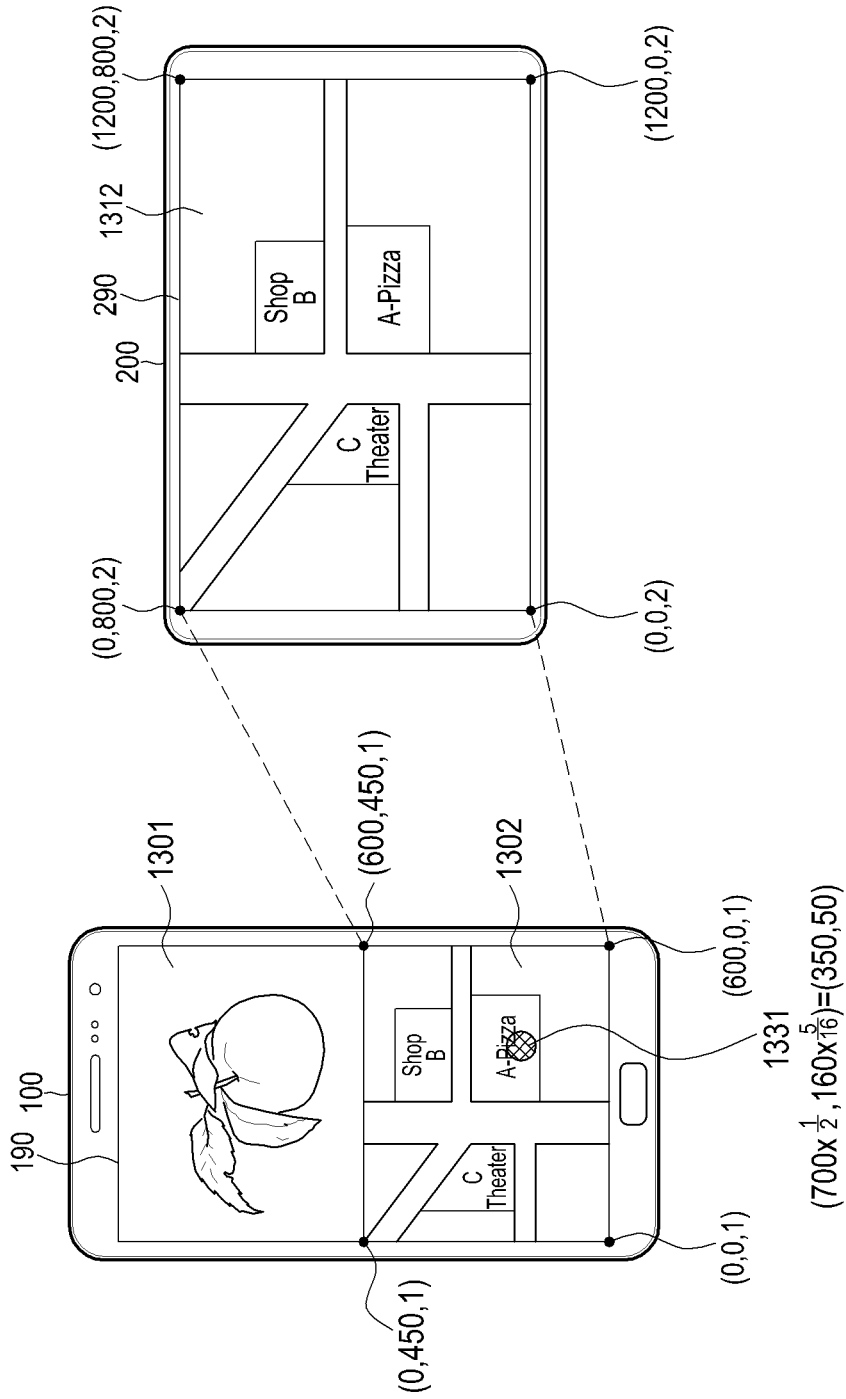

FIG.13B

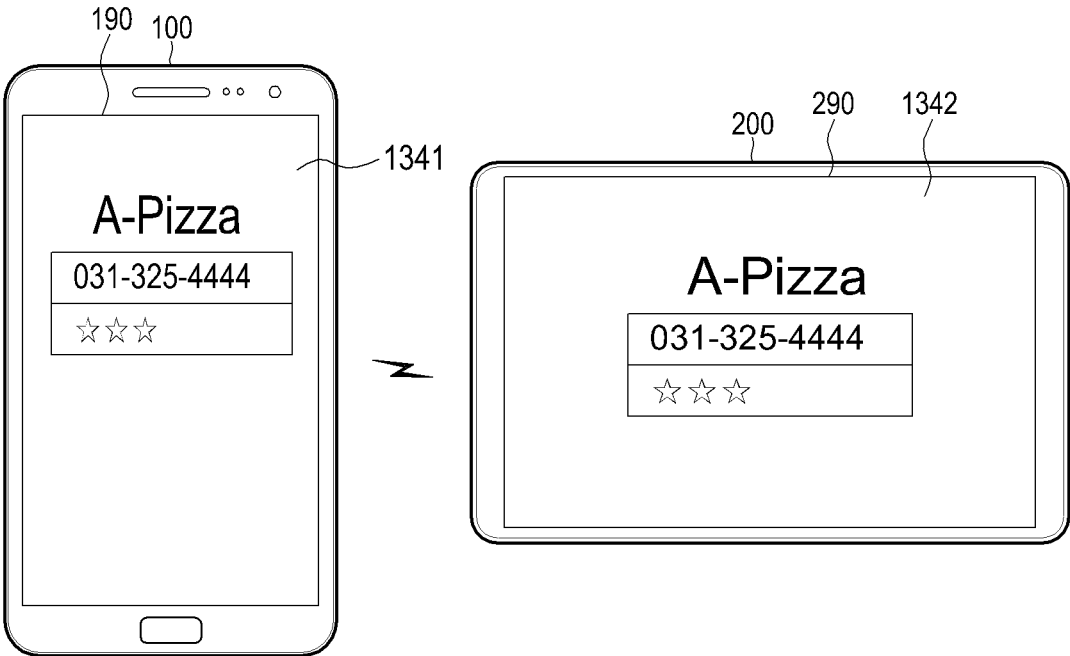

FIG.13C

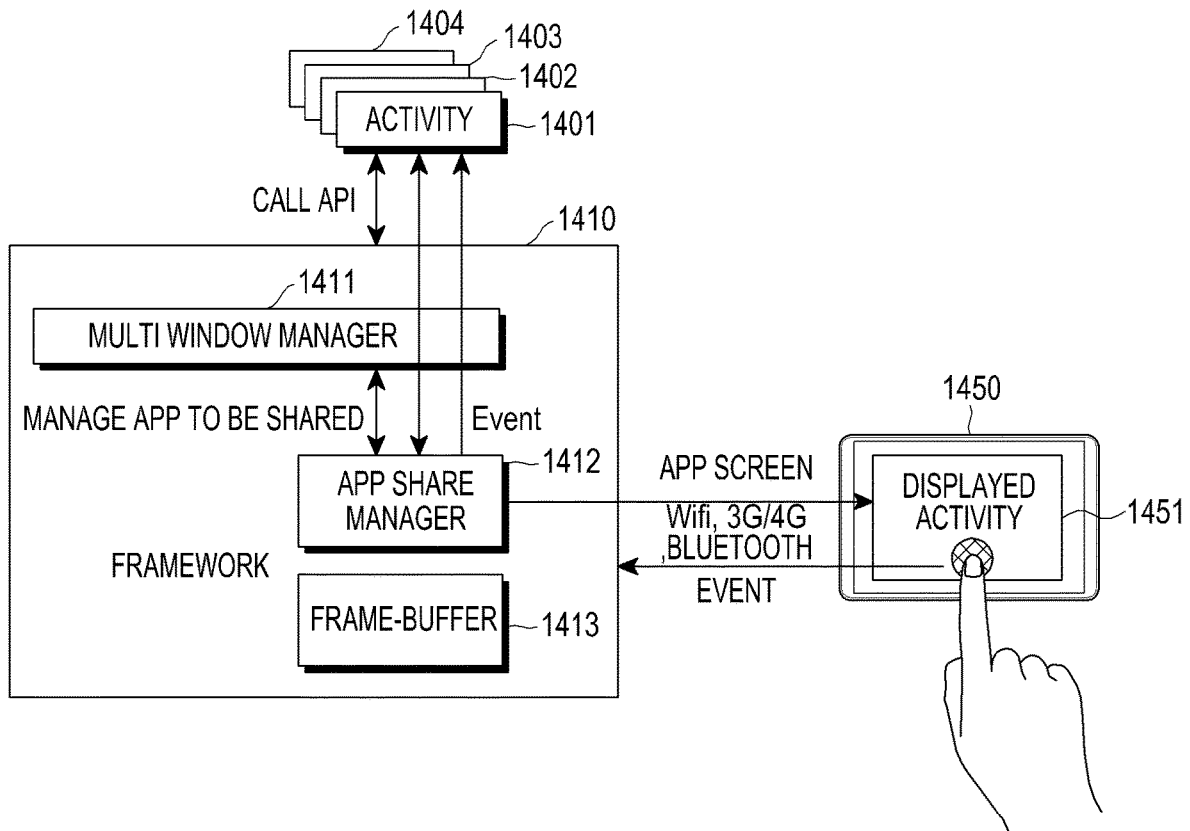

FIG.14

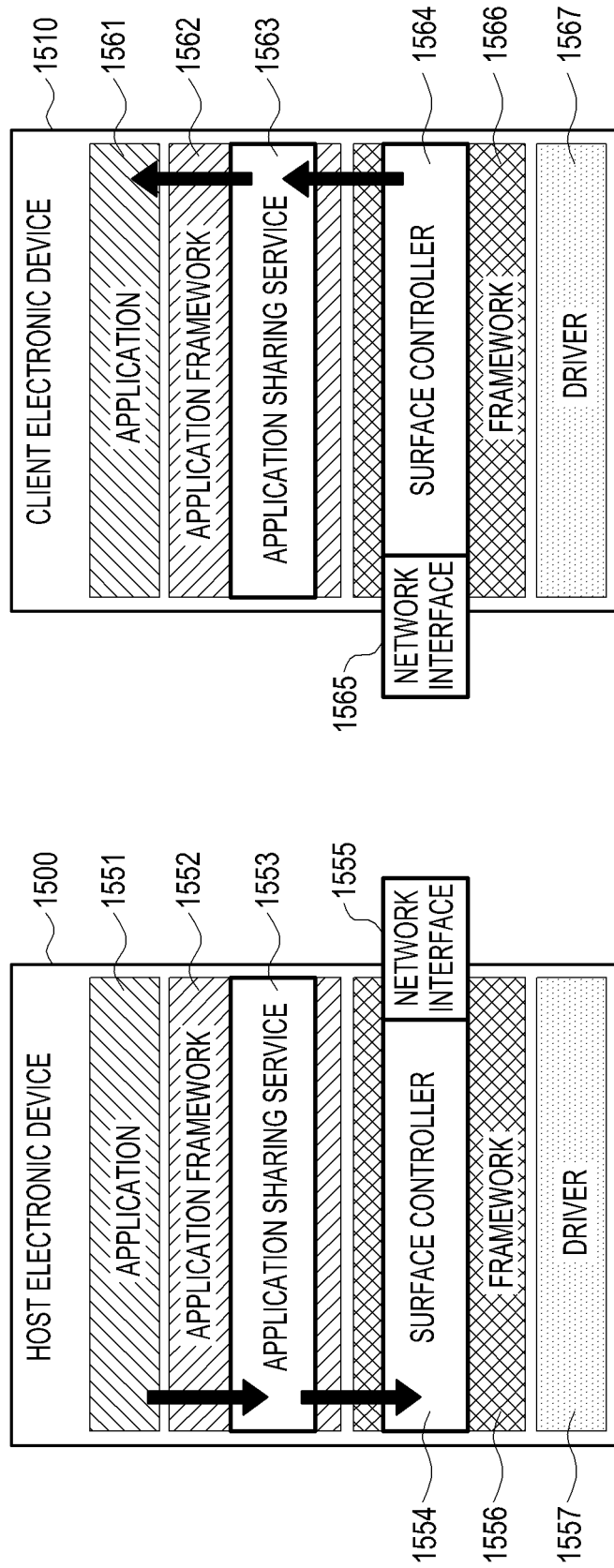
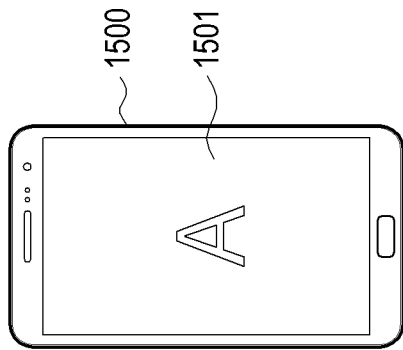
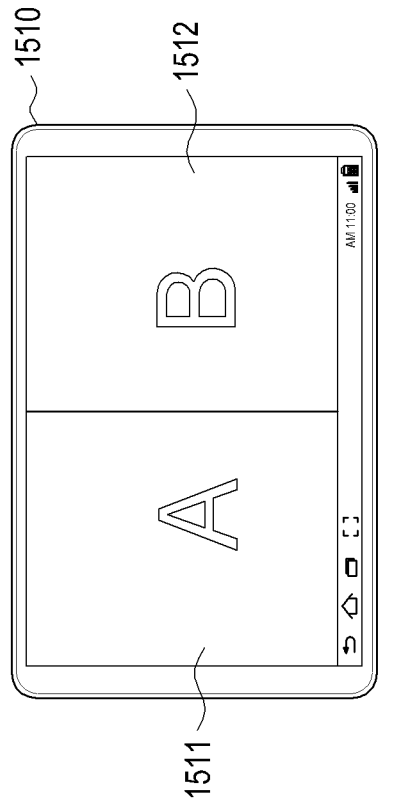

FIG.15

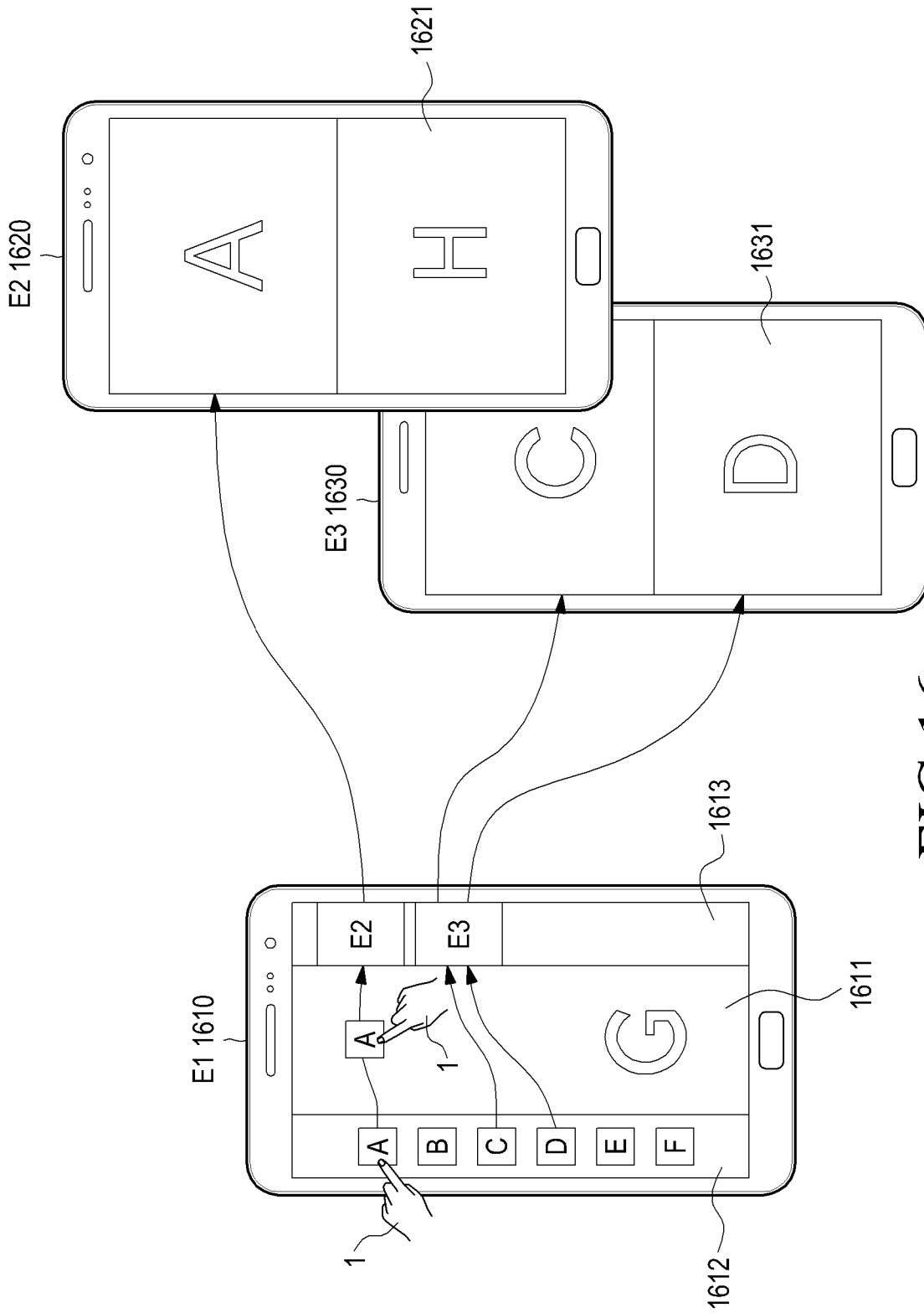

FIG.16

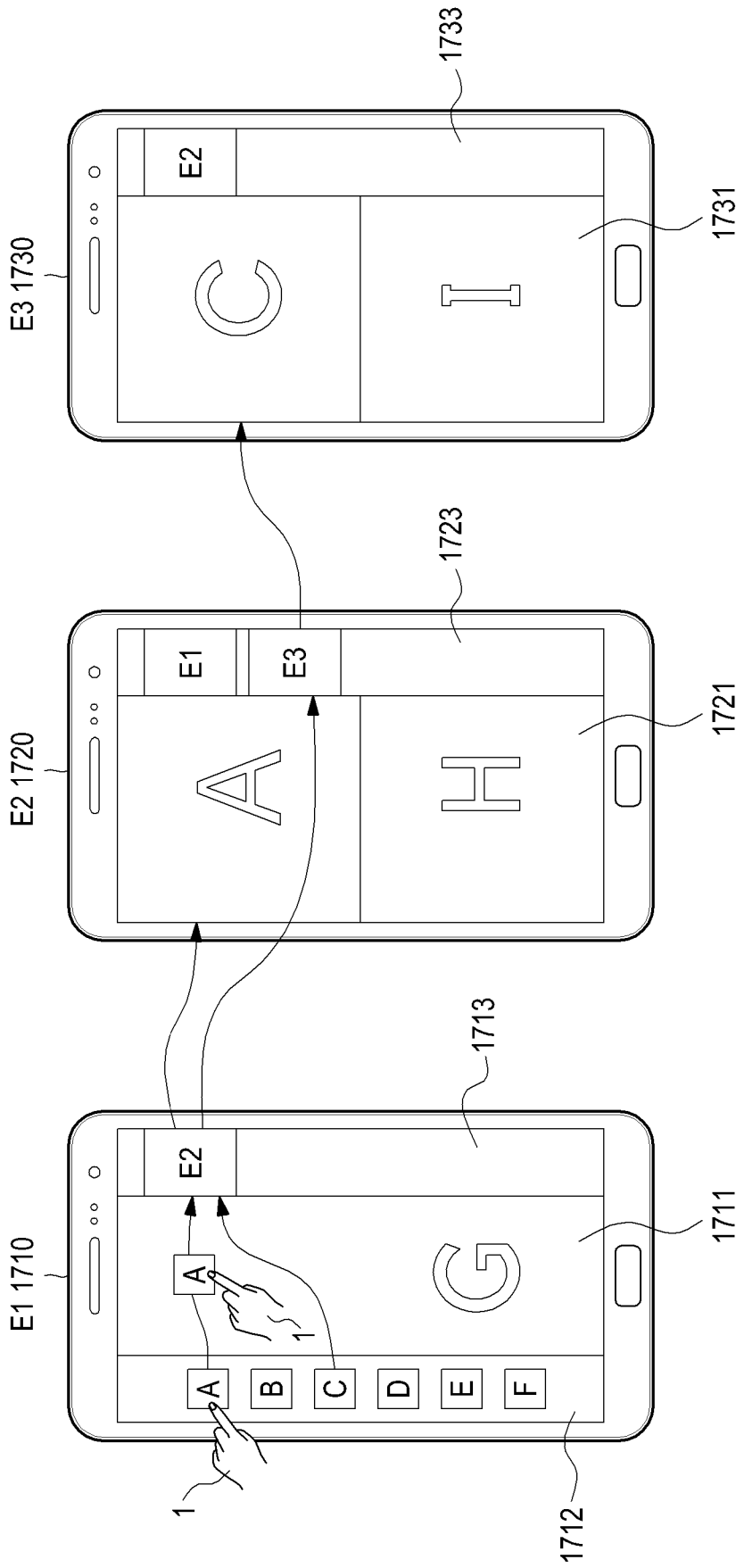

FIG.17

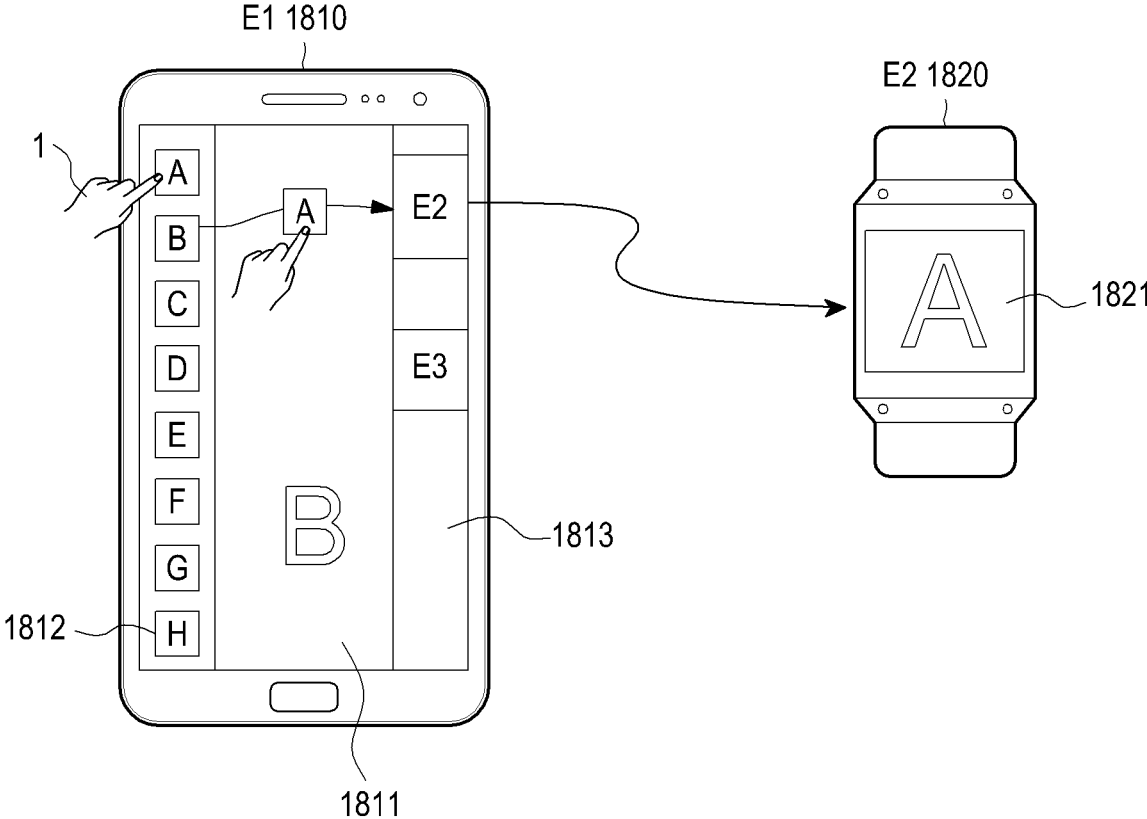

FIG.18

**ELECTRONIC DEVICE FOR SHARING
APPLICATION AND CONTROL METHOD
THEREOF**

Matter enclosed in heavy brackets [] appears in the original patent but forms no part of this reissue specification; matter printed in italics indicates the additions made by reissue; a claim printed with strikethrough indicates that the claim was canceled, disclaimed, or held invalid by a prior post-patent action or proceeding.

CROSS-REFERENCE TO RELATED
APPLICATION(S)

This application claims the benefit under 35 U.S.C. § 119(a) of a Korean patent application filed on Oct. 30, 2013 in the Korean Intellectual Property Office and assigned Serial number 10-2013-0130328, the entire disclosure of which is hereby incorporated by reference.

TECHNICAL FIELD

The present disclosure relates to an electronic device for sharing an application and a control method thereof. More particularly, the present disclosure relates to an electronic device for performing communication in a predetermined scheme to share an application and a control method thereof.

BACKGROUND

A desktop computer has at least one display device (for example, a monitor). A mobile device (for example, a mobile phone, a smart phone, or a tablet Personal Computer (PC)) using a touch screen has one display device.

A user of the desktop computer may divide a screen of the display device according to a working environment (for example, horizontally or vertically divide the screen while displaying a plurality of windows) and may use the divided screens. When a web browser is executed, the user can move in an upward or downward direction of the web page by using a page up button or a page down button arranged in a keyboard. When the user uses a mouse instead of the keyboard, the user can move in the upward or downward direction of the web page by selecting a scroll bar located on a side part of the web page by using a cursor of the mouse. Further, the user can move in the upward or downward direction of the web page by selecting a top button displayed as text or as an icon located at a bottom part of the web page.

The mobile device has a smaller size of the displayed screen in comparison with the desktop computer and a corresponding size limitation in regard to generating an input. The user may also have difficulty in dividing a display screen of the mobile device and then using the mobile device.

Further, the mobile device can execute various applications, such as basic applications produced by a manufacturer of the mobile device, and which are installed in the mobile device, and additional applications which may be downloaded from an application selling site through the Internet. The additional applications may be developed by ordinary users and may be registered in the application selling site. Accordingly, anyone can freely sell applications developed by himself or herself to users of the mobile device through the application selling site. As a result, mobile devices are currently provided with tens of thousands to hundreds of

thousands of applications free of charge or at costs which may vary among different products.

A various applications which stimulate consumers' curiosity and satisfy consumers' demands are provided in mobile devices, the mobile device is provided to have a portable size, and thus it has a limitation according to its size and a User Interface (UI) thereof. Accordingly, users may feel inconvenienced when executing a plurality of applications in the mobile device. As described above, this is because the display means of such a smart phone or a tablet Personal Computer (PC) is small, and thus there exists difficulty in identifying the plurality of applications. In order to overcome the limitations of the display, it is required to develop a technology to share an application with another electronic device. The related art provides a mirroring service in which an entire screen displayed on a display of one electronic device is shared with another electronic device. However, in the mirroring service of the related art, the entire screen of the display is shared with another electronic device so that a user has no choice but to share all parts of the screen, including a part which the user may not desire to share, with the other electronic device. Further, in the mirroring service, the other electronic device simply receives and displays only a screen, and cannot input any additional commands. As a result, the convenience felt by the user of the other electronic device deteriorates.

The above information is presented as background information only to assist with an understanding of the present disclosure. No determination has been made, and no assertion is made, as to whether any of the above might be applicable as prior art with regard to the present disclosure.

SUMMARY

Aspects of the present disclosure are to address at least the above-mentioned problems and/or disadvantages and to provide at least the advantages described below.

The present disclosure has been made to address the above problems and in response to a technology development request. Accordingly, an aspect of the present disclosure is to provide an electronic device which can share an application with another electronic device and a control method thereof.

In accordance with an aspect of the present disclosure, a control method of a host electronic device communicating with a client electronic device is provided. The control method includes forming a connection with the client electronic device, determining an application to be shared with the client electronic device, generating shared data for the application to be shared, and transmitting the shared data to the client electronic device.

In accordance with another aspect of the present disclosure, a host electronic device communicating with a client electronic device is provided. The host electronic device includes a communication unit configured to form a connection with the client electronic device, a controller configured to determine an application to be shared with the client electronic device, to generate shared data for the application to be shared, and to control the communication unit to transmit the shared data to the client electronic device, and a screen configured to display an execution screen of the application to be shared.

In accordance with another aspect of the present disclosure, a control method of a client electronic device sharing an application with a host electronic device is provided. The control method includes forming a connection with the host electronic device, receiving shared data for an application to

be shared with the host electronic device from the host electronic device, and outputting the shared data.

In accordance with another aspect of the present disclosure, an electronic device sharing an application with a host electronic device is provided. The electronic device includes a communication unit configured to form a connection with the host electronic device, and to receive shared data for an application to be shared with the host electronic device from the host electronic device, and a screen configured to output the shared data.

Other aspects, advantages, and salient features of the disclosure will become apparent to those skilled in the art from the following detailed description, which, taken in conjunction with the annexed drawings, discloses various embodiments of the present disclosure.

BRIEF DESCRIPTION OF THE DRAWINGS

The above and other aspects, features, and advantages of certain embodiments of the present disclosure will be more apparent from the following description taken in conjunction with the accompanying drawings, in which:

FIG. 1 is a block diagram illustrating a configuration of an electronic device according to an embodiment of the present disclosure;

FIG. 2 is an illustration of electronic devices sharing at least one application according to an embodiment of the present disclosure;

FIG. 3 is a flowchart illustrating operations of electronic devices which share at least one application according to an embodiment of the present disclosure;

FIG. 4 is a flowchart illustrating a process of a connection between one electronic device and another electronic device according to an embodiment of the present disclosure;

FIG. 5 is a flowchart illustrating a process of a connection between one electronic device and another electronic device according to an embodiment of the present disclosure;

FIGS. 6A, 6B, 6C, 6D, and 6E illustrate connection between electronic devices according to an embodiment of the present disclosure;

FIGS. 7A and 7B illustrate a coordinate setting method of a host electronic device according to an embodiment of the present disclosure;

FIG. 8 is a flowchart illustrating a control method of a host electronic device according to an embodiment of the present disclosure;

FIG. 9 is a flowchart illustrating a control method of a host electronic device and a client electronic device according to an embodiment of the present disclosure;

FIGS. 10A and 10B illustrate a host electronic device and a client electronic device sharing data according to an embodiment of the present disclosure;

FIG. 11 is a flowchart illustrating a method in which a host electronic device and a client electronic device share data according to an embodiment of the present disclosure;

FIG. 12 is a flowchart illustrating a method in which a host electronic device and a client electronic device share data according to an embodiment of the present disclosure;

FIGS. 13A, 13B, and 13C illustrate a method in which a host electronic device and a client electronic device share data according to an embodiment of the present disclosure;

FIG. 14 illustrates a system architecture of a host electronic device according to an embodiment of the present disclosure;

FIG. 15 illustrates layers in a host electronic device and a client electronic device according to an embodiment of the present disclosure;

FIG. 16 illustrates a method in which a host electronic device and a client electronic device share shared data according to an embodiment of the present disclosure;

FIG. 17 illustrates a method in which a host electronic device and a client electronic device share shared data according to an embodiment of the present disclosure; and

FIG. 18 illustrates a method in which a host electronic device and a client electronic device share shared data according to an embodiment of the present disclosure.

Throughout the drawings, like reference numerals will be understood to refer to like parts, components, and structures.

DETAILED DESCRIPTION

The following description with reference to the accompanying drawings is provided to assist in a comprehensive understanding of various embodiments of the present disclosure as defined by the claims and their equivalents. It includes various specific details to assist in that understanding but these are to be regarded as merely exemplary. Accordingly, those of ordinary skill in the art will recognize that various changes and modifications of the various embodiments described herein can be made without departing from the scope and spirit of the present disclosure. In addition, descriptions of well-known functions and constructions may be omitted for clarity and conciseness.

The terms and words used in the following description and claims are not limited to the bibliographical meanings, but, are merely used by the inventor to enable a clear and consistent understanding of the present disclosure. Accordingly, it should be apparent to those skilled in the art that the following description of various embodiments of the present disclosure is provided for illustration purpose only and not for the purpose of limiting the present disclosure as defined by the appended claims and their equivalent.

It is to be understood that the singular forms “a,” “an,” and “the” include plural referents unless the context clearly dictates otherwise. Thus, for example, reference to “a component surface” includes reference to one or more of such surfaces.

While terms including ordinal numbers, such as “first” and “second,” etc., may be used to describe various components, such components are not limited by the above terms. The terms are used merely for the purpose to distinguish an element from the other elements. For example, without departing from the scope of the present disclosure, a first structural element may be named a second structural element. Similarly, the second structural element also may be named the first structural element. The terms “and/or” includes combinations of a plurality of related items or a certain item among the plurality of related items.

The terms used in this application are for the purpose of describing various embodiments only and are not intended to be limiting of the disclosure. As used herein, the singular forms are intended to include the plural forms as well, unless the context clearly indicates otherwise. In the description, it should be understood that the terms “include” or “have” indicate existences of a feature, a number, a step, an operation, a structural element, parts, or a combination thereof, and do not exclude the existences or probability of addition of one or more another features, numeral, steps, operations, structural elements, parts, or combinations thereof.

Unless defined differently, all terms used herein, which include technical terminologies or scientific terminologies, have the same meaning as a person skilled in the art to which the present disclosure belongs. It should be interpreted that the terms, which are identical to those defined in general

dictionaries, have the meaning identical to that in the context of the related technique. The terms should not be ideally or excessively interpreted as a formal meaning.

FIG. 1 is a block diagram illustrating a configuration of an electronic device according to an embodiment of the present disclosure.

Referring to FIG. 1, the electronic device **100** may be connected to an external device (not shown) by using an external device connector such as a sub-communication module **130**, a connector **165**, and an earphone connecting jack **167** (not shown). The “external device” may include various devices attached to or detached from the electronic device **100** through a cable, such as an earphone, an external speaker, a Universal Serial Bus (USB) memory, a charger, a cradle, a docking station, a Digital Multimedia Broadcasting (DMB) antenna, a mobile payment related device, a health management device (e.g., a blood sugar tester, or the like), a game machine, a car navigation device, and the like. Further, the “external device” may include one of a short-range communication unit, such as a Bluetooth communication unit, a Near Field Communication (NFC) unit and a Wi-Fi direct communication device, and a wireless Access Point (AP), which are wirelessly connected to the electronic device **100** via short-range communication. In addition, the external device may include another device, a portable phone, a smart phone, a tablet Personal Computer (PC), a desktop PC, and a server.

The electronic device **100** may be a mobile electronic device as a representative example, but may be a tablet PC, a desktop PC, a smart TV, a notebook computer, an MP3 player and the like.

Referring to FIG. 1, the electronic device **100** may include a screen **190** and a screen controller **195**, and may further include at least one of a controller **110**, a communication unit including a mobile communication module **120** or the sub-communication module **130**, a multimedia module **140**, a camera module **150**, a Global Positioning System (GPS) module **155**, an input/output module **160**, a sensor module **170**, a storage unit **175**, and a power supply unit **180**. The sub-communication module **130** may include at least one of a wireless Local Area Network (LAN) module **131** and an -NFC module **132**, and the multimedia module **140** may include at least one of a broadcasting communication module **141**, an audio reproduction module **142**, and a video reproduction module **143**. The camera module **150** may include at least one of a first camera **151** and a second camera **152**. The input/output module **160** may include at least one of a button **161**, a microphone **162**, a speaker **163**, a vibration motor **164**, a connector **165**, a keypad **166**, and an earphone connecting jack **167**.

The controller **110** may include a Central Processing Unit (CPU) **111**, a Read Only Memory (ROM) **112** storing a control program for controlling the electronic device **100**, and a Random Access Memory (RAM) **113** used as a storage area for storing a signal or data input from the outside of the electronic device **100** or for work performed in the electronic device **100**. The CPU **111** may include a single core CPU, a dual core CPU, a triple core CPU, or a quadruple core CPU. The CPU **111**, the ROM **112** and the RAM **113** may be connected with one another through internal buses.

The controller **110** may control at least one of the mobile communication module **120**, the sub-communication module **130**, the multimedia module **140**, the camera module **150**, the GPS module **155**, the input/output module **160**, the sensor module **170**, the storage unit **175**, the power supply unit **180**, the screen **190**, and the screen controller **195**.

The mobile communication module **120** enables the electronic device **100** to be connected with the external device through mobile communication by using at least one antenna or a plurality of antennas (not shown) under a control of the controller **110**. The mobile communication module **120** may transmit/receive a wireless signal for a voice call, a video call, a Short Message Service (SMS), or a Multimedia Message Service (MMS) to/from a mobile phone (not shown), a smart phone (not shown), a tablet PC, or another device (not shown) having a phone number input into the electronic device **100**.

The sub-communication module **130** may include at least one of the wireless LAN module **131** and the short-range communication module **132**. For example, the sub-communication module **130** may include only the wireless LAN module **131**, only the short-range communication module **132**, or both the wireless LAN module **131** and the short-range communication module **132**.

The wireless LAN module **131** may be connected to the Internet at a location in which the wireless Access Point (AP) is installed, under a control of the controller **110**. The wireless LAN module **131** supports a wireless LAN standard (IEEE802.11x) of the Institute of Electrical and Electronics Engineers (IEEE). The short-range communication module **132** may wirelessly perform short distance communication between the electronic device **100** and an image forming apparatus (not shown) under a control of the controller **110**. A short-range communication scheme may include a Bluetooth communication scheme, an Infrared Data Association (IrDA) communication scheme, a WiFi-Direct communication scheme, a Near Field Communication (NFC) scheme and the like.

The electronic device **100** may include at least one of the mobile communication module **120**, the wireless LAN module **131**, and the short-range communication module **132** according to a performance of the electronic device **100**. For example, the electronic device **100** may include a combination of the mobile communication module **120**, the wireless LAN module **131**, and the short-range communication module **132** according to a performance of the electronic device **100**.

The multimedia module **140** may include the broadcasting communication module **141**, the audio reproduction module **142** or the video reproduction module **143**. The broadcasting communication module **141** can receive a broadcasting signal, e.g., a TV broadcasting signal, a radio broadcasting signal, or a data broadcasting signal, and broadcasting supplement information, e.g., Electric Program Guide (EPG) or Electric Service Guide (ESG), output from a broadcasting station through a broadcasting and communication antenna (not shown) under a control of the controller **110**. The audio reproduction module **142** may reproduce a stored or received digital audio file, e.g., a file having a file extension of mp3, wma, ogg, or wav, under a control of the controller **110**. The video reproduction module **143** may reproduce a stored or received digital video file, e.g., a file of which the file extension is mpeg, mpg, mp4, avi, mov, or mkv, under a control of the control unit **110**. The video reproduction module **143** may reproduce a digital audio file.

In various embodiments, the multimedia module **140** may include only the audio reproduction module **142** and the video reproduction module **143** except for the broadcasting communication module **141**. Although FIG. 1 illustrates that the audio reproduction module **142** and the video reproduction module **143** are included in the multimedia module **140**, the audio reproduction module **142** and the video reproduction module **143** of the multimedia module **140** may be

included in the controller **110** according to another embodiment of the present disclosure.

The camera module **150** may include at least one of the first camera **151** and the second camera **152** each of which photographs a still image or a video under a control of the control unit **110**. Further, the first camera **151** or the second camera **152** may include an auxiliary light source (for example, a flash (not shown)) providing light required for the photographing. The first camera **151** may be disposed on a front surface of the electronic device **100** and the second camera **152** may be disposed on a rear surface of the electronic device **100**. Alternatively, the first and second cameras **151** and **152** may be adjacently arranged (for example, an interval between the first camera **151** and the second camera **152** is larger than 1 cm and smaller than 8 cm), so as to photograph a three-dimensional still image or a three-dimensional video.

The GPS module **155** may receive radio waves from a plurality of GPS satellites (not shown) in Earth's orbit and calculate a position of the electronic device **100** by using Time of Arrival from the GPS satellites to the electronic device **100**.

The input/output module **160** may include at least one of the button **161**, the microphone **162**, the speaker **163**, the vibration device **164**, the connector **165**, and the keypad **166**.

The button **161** may be formed on a front surface, a side surface, or a rear surface of a housing of the electronic device **100**, and may include at least one of a power/lock button, a volume button, a menu button, a home button, a back button, and a search button.

The microphone **162** receives a voice or a sound to generate an electrical signal according to a control of the controller **110**.

The speaker **163** may output sounds corresponding to various signals (for example, a wireless signal, a broadcasting signal, a digital audio file, a digital video file, photographing or the like) of the mobile communication module **120**, the sub-communication module **130**, the multimedia module **140**, or the camera module **150** to the outside of the electronic device **100** under a control of the controller **110**. The speaker **163** may output a sound (for example, button tone corresponding to phone communication, ringing tone, and a voice of another user) corresponding to a function performed by the electronic device **100**. One or more speakers **163** may be formed on a proper position or positions of the housing of the electronic device **100**.

The vibration motor **164** may convert an electric signal to a mechanical vibration under a control of the control unit **110**. For example, when the electronic device **100** in a vibration mode receives a voice call from another device (not shown), a vibration motor is operated. One or more vibration motors **164** may be formed within the housing of the electronic device **100**. The vibration motor **164** may operate in response to a touch action of the user made on the screen **190** or successive movements of the touch on the screen **190**.

The connector **165** may be used as an interface for connecting the electronic device **100** with an external device (not shown) or a power source (not shown). The electronic device **100** may transmit or receive data stored in the storage unit **175** of the electronic device **100** to or from an external device (not shown) through a wired cable connected to the connector **165** according to a control of the controller **110**. At this time, the external device may be a docking station, and the data may be an input signal transmitted from an external input device, for example, a mouse, a keyboard or the like. Further, the electronic device **100** may receive

power from the power source (not shown) through the wired cable connected to the connector **165** or charge a battery (not shown) by using the power source.

The keypad **166** may receive a key input from the user for the control of the electronic device **100**. The keypad **166** may include a physical keypad (not shown) formed in the electronic device **100** or a virtual keypad (not shown) displayed on the screen **190**. The physical keypad (not shown) formed in the electronic device **100** may be excluded according to the performance or a structure of the electronic device **100**.

An earphone (not shown) may be inserted into the earphone connecting jack **167** to be connected with the electronic device **100**.

The sensor module **170** may include at least one sensor for detecting a status of the electronic device **100**. For example, the sensor module **170** may include a proximity sensor for detecting proximity of a user to the electronic device **100**, and an illumination sensor for detecting the amount of light near the electronic device **100**. Further, the sensor module **170** may include a gyro sensor. The gyro sensor may detect the operation of the electronic device **100** (for example, rotation of the electronic device **100**, or acceleration or vibration applied to the electronic device **100**), may detect a point of the compass using the magnetic field on Earth, or may detect a gravity acting direction. Further, the sensor module **170** may include an altimeter for measuring an atmospheric pressure to detect an altitude. As described above, at least one sensor included in the sensor module **170** may detect the status of the electronic device **100** according to each function thereof, generate a signal corresponding to the detection, and transmit the generated signal to the controller **110**. The sensors of the sensor module **170** may be added or omitted according to the performance of the electronic device **100**.

The storage unit **175** may store an input/output signal or data corresponding to the operation of the communication module **120**, the sub-communication module **130**, the multimedia module **140**, the camera module **150**, the GPS module **155**, the input/output module **160**, the sensor module **170**, or the screen **190**. The storage unit **175** may store a control program and applications for controlling the electronic device **100** or the controller **110**.

The term "storage unit" includes the storage unit **175**, the ROM **112** or the RAM **113** within the controller **110**, or a memory card (not shown) (for example, an SD card or a memory stick) mounted to the electronic device **100**. Further, the storage unit may include a nonvolatile memory, a volatile memory, a Hard Disk Drive (HDD), or a Solid State Drive (SSD).

The power supplier **180** may supply power to one or more batteries (not shown) disposed on the housing of the electronic device **100** according to a control of the controller **110** and the one or more batteries (not shown) may supply power to the electronic device **100**. Further, the power supplier **180** may supply power input from an external power source (not shown) through the wired cable connected to the connector **165** to the electronic device **100**. In various embodiments, the power supplier **180** may supply power wirelessly input from the external electric power source through a wireless charging technology to the electronic device **100**.

The screen **190** may be implemented by a touch screen which can detect a touch as an input of the user. The screen **190** may provide the user with a UI corresponding to various services (for example, a voice call, data transmission, broadcasting, and photographing). The screen **190** may transmit an analog signal corresponding to at least one touch input

into the user interface, to the screen controller **195**. The screen **190** may receive at least one touch through a body of the user (for example, fingers including a thumb) or a touchable input means (for example, a stylus pen or the like). Further, the screen **190** may receive successive movements of one touch among the at least one touch. The screen **190** may transmit an analog signal corresponding to the successive movements of the input touch to the screen controller **195**.

In the present disclosure, the touch is not limited to a contact between the screen **190** and the user's body or to the touchable input means, and may include a non-contact touch event. A distance of the non-contact touch event, which can be detected by the screen **190**, may be changed according to the performance or the structure of the electronic device **100**.

The screen **190** may be implemented in various screen types, for example, a resistive type, a capacitive type, an Electronic Magnetic Resonance (EMR) type (hereinafter, referred to as an EMR type), an infrared type, an acoustic wave type, or a combination thereof.

The screen controller **195** converts an analog signal received by the screen **190** to a digital signal (for example, X and Y coordinates) and transmits the converted digital signal to the controller **110**. The controller **110** may control the screen **190** by using the digital signal received from the screen controller **195**. For example, the controller **110** may allow a short-cut icon (not shown) displayed on the screen **190** to be selected or execute an operation corresponding to the short-cut icon (not shown) in response to the touch. The screen controller **195** may be included in the controller **110** in various embodiments.

FIG. 2 is an illustration of electronic devices sharing at least one application according to an embodiment of the present disclosure.

Referring to FIG. 2, a host electronic device, that is, a first electronic device **100** which shares at least one application with each of client electronic devices, such as a second electronic device **200**, a third electronic device **300**, and a fourth electronic device **400** will be described herein. The first electronic device **100** may share at least one application which is being executed in the first electronic device **100** with the second electronic device **200**, the third electronic device **300**, and the fourth electronic device **400**. In an embodiment, the first electronic device **100**, which executes the application and shares the executed application or a screen displaying the executed application with other electronic devices, is referred to as a "host electronic device". Further, the second to fourth electronic devices **200**, **300**, and **400**, which receive data related to the application to be shared, for example, the screen displaying the executed application from the host electronic device and output the received data, are referred to as "client electronic devices".

The first electronic device **100** may display a first application execution screen **191** executing a first application A and a second application execution screen **192** executing a second application B. The first electronic device **100** may display the first application execution screen **191** and the second application execution screen **192** on the screen **190** in a split mode. That is, the first electronic device **100** may display the first application execution screen **191** and the second application execution screen **192** on different separated regions of the screen **190** as illustrated in FIG. 2.

According to another embodiment, the first electronic device **100** may display the first application execution screen **191** and the second application execution screen **192** on the screen **190** in a free style mode. The first electronic device **100** may assign a display priority to each of the first

application execution screen **191** and the second application execution screen **192**, and the first application execution screen **191** and the second application execution screen **192** may be overlappingly displayed on the screen **190** based on the assigned priority. As described above, the host electronic device, for example, the first electronic device **100** may output the screens executing a plurality of applications to the screen **190** in the split mode or the free style mode and also display the screens on the screen **190** in various ways.

Referring to FIG. 2, the first electronic device **100** displays the first application execution screen **191** and the second application execution screen **192** in the split mode. A plurality of objects related to the applications A and B may be displayed on the first application execution screen **191** and the second application execution screen **192**. The objects which can be displayed on the application execution screens may include various forms, such as text, a figure, an icon, a button, a checkbox, a picture, a video, a web, a map and the like. When a user touches an object displayed on the screen, the controller **110** of the first electronic device **100** may control an application to execute a function predetermined for the object or an event corresponding to the object. Further, the object may be called a view according to an operating system.

In the embodiment of FIG. 2, it is assumed that the first electronic device **100** further executes a third application C. That is, it is assumed that the first electronic device **100** executes the first application A, the second application B, and the third application C. Further, it is assumed that the first electronic device **100** of FIG. 2 does not display the third application C on the screen **190**. As described above, the first electronic device **100** can perform a calculation by the third application C while executing the third application C, but may not display a result of the execution of the third application C on the screen **190**.

It is assumed that the first electronic device **100** shares the first application A with the second electronic device **200**. Further, it is assumed that the first electronic device **100** shares the second application B with the third electronic device **300**. In addition, it is assumed that the first electronic device **100** shares the third application C with the fourth electronic device **400**. Accordingly, the first electronic device **100** may form a connection with each of the second electronic device **200**, the third electronic device **300** and the fourth electronic device **400**. The first electronic device **100** may transmit first shared data, second shared data and third shared data to the second electronic device **200**, the third electronic device **300**, and the fourth electronic device **400**, respectively. At this time, the first shared data may include at least one of video data, graphic data, audio data, and display information as an output result of the first application A. The second shared data may be an output result of the second application B and the third shared data may be an output result of the third application C.

The second electronic device **200** may output the first shared data received from the first electronic device **100** on the screen **290**. For example, the second electronic device **200** may display a first application execution screen **211** on a screen **290**. The third electronic device **300** may output the received second shared data on a screen **390**. For example, the third electronic device **300** may display a second application execution screen **312** on a screen **390**. The fourth electronic device **400** may output the third shared data received from the first electronic device **100** on a screen **490**. For example, the fourth electronic device **400** may display a third application execution screen **413** on the screen **490**.

11

Although FIG. 2 illustrates that the client electronic devices (for example, the second electronic device 200, the third electronic device 300 and the fourth electronic device 400) simply display predetermined data on their displays, it is only an example. In various embodiments, the client electronic device (for example, the second electronic device 200, the third electronic device 300 or the fourth electronic device 400) may receive at least one of display data and voice or vibration multimedia output related data from the host electronic device (for example, the first electronic device 100), and accordingly may display predetermined data on displays (for example, screens) and may also provide various voice or vibration multimedia outputs.

The client electronic devices, that is, the second electronic device 200 to the fourth electronic device 400, may output the shared data received from the host electronic device without any change or after changing the shared data in accordance with characteristics of the devices. For example, the second electronic device 200 may display the first application execution screen 211 at the same aspect ratio as that of the first application execution screen 191 displayed by the first electronic device 100. The third electronic device 300 receives the second application execution screen 192 displayed by the first electronic device 100 and may display the second application execution screen 312 of which an aspect ratio has been converted in accordance with the third electronic device 300. Alternatively, in another embodiment, the shared data may be transmitted without any change or after a conversion according to each of the client electronic devices (for example, the second electronic device 200, the third electronic device 300 and the fourth electronic device 400) connected to the first electronic device 100 corresponding to the host electronic device. For example, the first electronic device 100 may transmit the first application execution screen 211 to the second electronic device 200, the second application execution screen 312 to the third electronic device 300 and the third application execution screen 413 to the fourth electronic device 400.

Referring to FIG. 2, the second electronic device 200 receives the first shared data corresponding to the first application execution screen 191 from the first electronic device 100 and may display the first application execution screen 211 on the screen 290. The third electronic device 300 receives the second shared data corresponding to the second application execution screen 192 from the first electronic device 100 and may display the second application execution screen 312 on the screen 390. The fourth electronic device 400 receives the third shared data corresponding to the third application execution screen (not shown) from the first electronic device 100 and may display the third application execution screen 413 on the screen 490.

In various embodiments, the host electronic device determines the client electronic device as a connected output device, and thus may be designed to not influence a conventional application execution mechanism. The client electronic device may recognize the host electronic device as an external device or a cloud server.

FIG. 3 is a flowchart illustrating operations of electronic devices which share at least one application according to an embodiment of the present disclosure.

Referring to FIG. 3, the first electronic device 100 forms a connection with the second electronic device 200 in S2. When the connection with the second electronic device 200 is formed, the first electronic device 100 adds the second electronic device 200 to a registered electronic device list in operation S4. In order to add the second electronic device 200 to the registered electronic device list in operation S4,

12

the first electronic device 100 may receive second electronic device information from the second electronic device 200 and store the received second electronic device information. The second electronic device information may include at least one of an identification, display size information, resolution information, display information, Dots Per Inch (DPI), and voice or vibration multimedia output related information of the second electronic device 200. In various embodiments, the second electronic device information may be encrypted and thus improve security.

The first electronic device 100 determines an application to be shared with the second electronic device 200 in operation S6. For example, the first electronic device 100 may determine an application to be shared with the second electronic device 200 based on a user input. The first electronic device 100 may display a list of applications which can be shared with the second electronic device 200 on the screen 190, and the user may make a user input for designating at least one application included in the application list displayed on the screen 190. The first electronic device 100 may determine the application to be shared based on the user input. Such a method of determining the application to be shared based on the user input may be performed through a menu or according to a system function, such as an environment setting. When the application to be shared is determined through the menu, the user may select the application to be shared according to a sharing sequence or an assigned identification. According to another embodiment, the first electronic device 100 may display a function key for designating the application to be shared on the screen 190 and determine the application to be shared based on a designation of the displayed function key by the user.

According to another embodiment, the first electronic device 100 may store the application to be shared in a default form. For example, when the first electronic device 100 executes the application to be shared set by default, the first electronic device 100 may share the application with the second electronic device 200. The first electronic device 100 may set the corresponding application as an application to be shared by default in a file configuring attributes of the application. For example, in a case of an Android platform, the first electronic device 100 may set a manifest file as an application to be shared by default. A framework may make a control such that the application to be shared set by default in accordance with the application attributes is shared with another electronic device.

When the application to be shared is determined, the first electronic device 100 generates shared data in operation S8. The shared data may be an output of the application to be shared. The first electronic device 100 may generate shared data including voice or vibration data output from the application to be shared as well as display data of the application to be shared. In various embodiments, the first electronic device 100 may extract and generate only data output from the application to be shared as the shared data instead of all data output from the first electronic device 100.

When the shared data is generated, the first electronic device 100 transmits the generated shared data to the second electronic device 200 in operation S10. The first electronic device 100 may transmit the shared data to the second electronic device 200 based on a short distance communication scheme, such as Bluetooth, Bluetooth low energy, IrDA, WiFi-Direct communication, NFC or the like.

According to an embodiment, the client electronic devices (for example, the second electronic device 200 to the fourth electronic device 400) may use an accessory supporting WiFi-Direct. For example, when NFC is used, based on

13

bumping detected by an NFC reader, automatic sharing may be performed in the detection. The host electronic device (for example, the first electronic device 100) may use the client electronic devices and a network protocol or a mechanism, such as streaming or Virtual Private Network (VPN).

In various embodiments, the first electronic device 100 may transmit the shared data to a relay server (not shown) based on wireless data transmission and the relay server (not shown) may relay the shared data received from the first electronic device 100 to the second electronic device 200. Accordingly, the first electronic device 100 may share an application with the second electronic device 200 at a distance exceeding a range within which the short distance communication is possible.

According to another embodiment, the first electronic device 100 may transmit the share data to the second electronic device 200 based on a wired communication scheme. For example, the first electronic device 100 may transmit the shared data to the second electronic device 200 through a High Definition Multimedia Interface (HDMI) cable or a USB cable.

The second electronic device 200 having received the shared data from the first electronic device 100 in operation S10 outputs the shared data received from the first electronic device 100 in operation S12. The second electronic device 200 may receive at least one of display data and voice or vibration multimedia output related data from the first electronic device 100, and accordingly, display predetermined data on the display and also provide various voice or vibration multimedia outputs.

As described above, the first electronic device 100 may share the application with the second electronic device 200. Hereinafter, operation S2 in which the first electronic device 100 forms the connection with the second electronic device 200 will be described in more detail.

FIG. 4 is a flowchart illustrating a process of forming a connection between one electronic device and another electronic device according to an embodiment of the present disclosure.

Referring to FIG. 4, the connection between the first electronic device 100 and the second electronic device 200 will be described. In FIG. 4, it is assumed that the first electronic device 100 is the host electronic device and the second electronic device 200 is the client electronic device.

The first electronic device 100 first recognizes a neighboring device, for example, the second electronic device in operation S22. The neighboring device may refer to an electronic device which can perform short distance communication with the first electronic device 100. In various embodiments, the neighboring device may refer to an electronic device which can transmit/receive data through a relay server (not shown).

For example, when the first electronic device 100 is set to share an application with another electronic device through a Bluetooth low energy scheme, the first electronic device 100 may recognize the second electronic device 200 based on an advertisement signal transmitted from the second electronic device 200. Further, the first electronic device 100 may recognize a neighboring device based on a method of recognizing another electronic device in the preset short distance communication scheme. In various embodiments, when the first electronic device 100 is set to share an application with another device, for example, the second electronic device 200 through a relay server (not shown), the first electronic device 100 may recognize a neighboring device based on whether the second electronic device 200 is connected to the relay server (not shown).

14

When the first electronic device 100 recognizes the neighboring device, such as the second electronic device 200, the first electronic device 100 transmits an application sharing request to the second electronic device 200 in operation S24. The application sharing request may include requests for information regarding the application to be shared, device information of the first electronic device 100, an identification of the first electronic device 100, device information of the second electronic device 200 and the like.

The second electronic device 200 transmits the device information of the second electronic device 200 in response to the application sharing request of the first electronic device 100 in operation S26. In various embodiments, the second electronic device 200 may inform the user of application sharing by displaying an inquiry message of the application sharing on the screen 290. Further, the second electronic device 200 may transmit the device information to the first electronic device 100 when the user agrees to the application sharing.

As described above, when the first electronic device 100 receives the device information from the second electronic device 200 in operation S26, the connection between the first electronic device 100 and the second electronic device 200 is formed in operation S28.

FIG. 5 is a flowchart illustrating a process of forming a connection between one electronic device and another electronic device according to an embodiment of the present disclosure.

Referring to FIG. 5, like in FIG. 4, it is assumed that the first electronic device 100 is the host electronic device and the second electronic device 200 is the client electronic device. On the contrary to the embodiment of FIG. 4, FIG. 5 describes a case in which the second electronic device 200 corresponding to the client electronic device makes a request for sharing an application to the first electronic device 100 corresponding to the host electronic device.

Referring to FIG. 5, the second electronic device 200 first recognizes a neighboring device, for example, the first electronic device 100 in operation S32. As described above in FIG. 4, the second electronic device 200 may recognize a neighboring device based on a method of recognizing another electronic device in the preset short distance communication scheme. In various embodiments, the first electronic device 100 may be set to share an application with the second electronic device 200 through a relay server (not shown). In this event, the second electronic device 200 may recognize the neighboring device, for example, the first electronic device 100 based on whether the first electronic device 100 is connected to the relay server (not shown).

When the second electronic device 200 recognizes the neighboring device, the second electronic device transmits an application sharing request to the first electronic device 100 in operation S34. The application sharing request may include at least one of information regarding the application to be shared and a purpose of the application sharing.

For example, the second electronic device 200 may receive a list of applications which can be shared from the first electronic device 100 and display the application list on the screen 290. Further, the second electronic device 200 may transmit a sharing request for sharing an application selected by user from the applications included in the application list, which can be shared, displayed on the screen 290 as the application to be shared to the first electronic device 100.

The first electronic device 100 having received the application sharing request from the second electronic device 200 permits the corresponding application sharing in operation

S36. The first electronic device **100** having received the inquiry message of the application sharing from the second electronic device **200** in operation S34 may display the corresponding inquiry message on the screen **190**. The first electronic device **100** may receive a user input for determining whether to share the application with the second electronic device **200** from the user.

The first electronic device **100** may make a request for device information corresponding to the second electronic device **200** to the second electronic device **200** when the user agrees to the application sharing. Accordingly, the second electronic device **200** transmits the device information to the first electronic device **100** in response to the request for the device information in operation S38. When the first electronic device **100** receives the device information from the second electronic device **200**, the connection between the first electronic device **100** and the second electronic device **200** is formed in operation S40.

As described above, the first electronic device **100** may form the connection with the second electronic device **200** by itself or form the connection in response to a request for the connection by the second electronic device **200**.

FIGS. 6A 6B, 6C, 6D, and 6E illustrate a connection between electronic devices according to an embodiment of the present disclosure.

Referring to FIGS. 6A to 6E, it is assumed that the first electronic device **100** is the host electronic device.

As illustrated in FIG. 6A, the first electronic device **100** corresponding to the host electronic device may be connected with the client electronic device, for example, the second electronic device **200** in a 1:1 correspondence. When the first electronic device **100** and the second electronic device **200** are connected to each other, the first electronic device **100** may share the executed first application A with the second electronic device **200**. In various embodiments, the first electronic device **100** may share all the executed applications A and B with the second electronic device **200**. Further, the first electronic device **100** may share the third application C which is being executed but is not displayed with the second electronic device **200**.

Referring to FIG. 6A, the first electronic device **100** corresponding to the host electronic device is connected with the second electronic device **200** corresponding to the client electronic device. Further, the first electronic device **100** executes the first application A and the second application B. The first application execution screen **191** executing the first application A is displayed and the second application execution screen **192** executing the second application B is displayed on the screen **190** of the first electronic device **100**. In FIG. 6A, it is assumed that the first electronic device **100** and the second electronic device **200** share only the first application A. The first electronic device **100** may generate shared data corresponding to the first application A or the first application execution screen **191** and transmit the generated shared data to the second electronic device **200**. The second electronic device **200** sharing the first application A with the first electronic device **100** may receive the shared data from the first electronic device **100** and display the first application execution screen **211** on the screen **190**.

Referring to FIG. 6B, it is assumed that the first electronic device **100** is the host electronic device, and each of the second electronic device **200**, the third electronic device **300**, and the fourth electronic device **400** is the client electronic device.

As illustrated in FIG. 6B, the first electronic device **100** may share at least one of the first application A, the second application B, and the third application C with each of the

second electronic device **200**, the third electronic device **300**, and the fourth electronic device **400**. In FIG. 6B, the first electronic device **100** executes the first application A, the second application B, and the third application C, but displays only the first application execution screen **191** and the second application execution screen **192** on the screen **190**. Further, it is assumed that the first electronic device **100** shares the first application A with the second electronic device **200**, the second application B with the third electronic device **300**, and third application C with the fourth electronic device **400**. In FIG. 6B, even though the application execution screen executing the third application C is not displayed on the screen **190** of the first electronic device **100**, the first electronic device **100** according to the an embodiment may share the third application C with the fourth electronic device **400** by generating shared data corresponding to the third application and transmitting the generated shared data to the fourth electronic device **400**.

Accordingly, the first application execution screen **211** executing the first application A may be displayed on the screen **290** of the second electronic device **200** which shares the first application A with the first electronic device **100**. The second application execution screen **212** executing the second application B may be displayed on the screen **390** of the third electronic device **300** which shares the second application B with the first electronic device **100**. Further, the third application execution screen **213** executing the third application C may be displayed on the screen **490** of the fourth electronic device **400** which shares the third application C with the first electronic device **100**.

Referring to FIG. 6C, the figure illustrates a concept for describing connections among a plurality of host electronic devices. In FIG. 6C, it is assumed that the host electronic devices are the first electronic device **100** and a fifth electronic device **500**.

The first electronic device **100** executes the first application A and accordingly displays the first application execution screen **191** on the screen **190**. The fifth electronic device **500** executes the second application B and accordingly displays a second application execution screen **512** on a screen **590**.

Referring to FIG. 6C, it is assumed that the first electronic device **100** shares the first application A with the second electronic device **200** corresponding to the client electronic device, and the fifth electronic device **500** share the second application B with the second electronic device **200**. Accordingly, the first electronic device **100** may generate first shared data corresponding to the first application A and transmit the first shared data to the second electronic device **200**. Further, the fifth electronic device **500** may generate second shared data corresponding to the second application B and transmit the second shared data to the second electronic device **200**.

The second electronic device **200** may output the first shared data and the second shared data received from the first electronic device **100** and the fifth electronic device **500** on the screen **290**. The second electronic device **200** may display the first application execution screen **211** and the second application execution screen **212** on the screen **290** as illustrated in FIG. 6C.

Further, the second electronic device **200** may display each of the first application execution screen **211** and the second application execution screen **212** in a window form as illustrated in FIG. 6C. The second electronic device **200** may assign a display priority to each of the first application execution screen **211** and the second application execution screen **212**. For example, the second electronic device **200**

17

may assign a higher display priority to the first application execution screen 211 in comparison with the second application execution screen 212. Accordingly, the second electronic device 200 may display the application execution screens such that the first application execution screen 211 overlaps a part or all of the second application execution screen 212.

FIG. 6D illustrates concepts of electronic devices according to another embodiment of the present disclosure. In FIG. 6D, it is assumed that the first electronic device 100 and the fifth electronic device 500 are the host electronic devices, and the second electronic device 200 and a sixth electronic device 600 are the client electronic devices. Further, in FIG. 6D, it is assumed that the fifth electronic device 500 operates as the host electronic device with respect to the sixth electronic device 600 and as the client electronic device with respect to the first electronic device 100. Like the fifth electronic device 500, the electronic devices according to an embodiment may operate as both the host electronic device and the client electronic device.

Referring to FIG. 6D, the first electronic device 100 executes the first application A and the second application B. Accordingly, the first application execution screen 191 executing the first application A and the second application execution screen 192 executing the second application B may be displayed on the screen of the first electronic device 100. Further, the first electronic device 100 operating as the host electronic device shares the first application A the second electronic device 200 corresponding to the client electronic device. Accordingly, the second electronic device 200 may display the second application execution screen 211 executing the second application B on the screen 290.

Referring to FIG. 6D, the first electronic device 100 operating as the host electronic device shares the first application A and the second application B with the fifth electronic device 500 operating as the client electronic device. Accordingly, a first application execution screen 511 executing the first application A and a second application execution screen 512 executing the second application B may be displayed on a screen 590 of the fifth electronic device 500.

The fifth electronic device 500 operates as the host electronic device and may share the second application B with the sixth electronic device 600 corresponding to the client electronic device. That is, the fifth electronic device 500 may share the application execution screen 512 executing the second application B with the sixth electronic device 600. Accordingly, the sixth electronic device 600 may display a second application execution screen 612 executing the second application B on a screen 690.

Referring to FIG. 6E, the figure illustrates concepts of electronic devices according to still another embodiment of the present disclosure. In FIG. 6E, it is assumed that the first electronic device 100 is the host electronic device and a seventh electronic device 700 and an eighth electronic device 800 are the client electronic devices. The first electronic device 100 executes the first application A and the second application B. Accordingly, the first electronic device 100 displays the first application execution screen 191 executing the first application A and the second application execution screen 192 executing the second application B on the screen 190. In FIG. 6E, it is assumed that the first electronic device 100 displays the first application execution screen 191 and the second application execution screen 192 in the freestyle mode. That is, the first electronic device 100 may assign a display priority to each of the first application execution screen 191 and the second application execution

18

screen 192. For example, in FIG. 6E, the first electronic device 100 may assign a higher display priority to the second application execution screen 192 in comparison with the first application execution screen 191. Accordingly, the first electronic device 100 may make a control such that the second application execution screen 192 is displayed on the screen 190 in an area of the screen 190 where the first application execution screen 191 and the second application execution screen 192 overlap with each other. That is, the first application execution screen 191 may not be displayed on the screen 190 in an area of the screen 190 where the first application execution screen 191 and the second application execution screen 191 overlap with each other.

Referring to FIG. 6E, it is assumed that the first electronic device 100 corresponding to the host electronic device shares the first application A with the seventh electronic device 700 corresponding to the client electronic device. Further, it is assumed that the first electronic device 100 shares the second application B with the eighth electronic device 800 corresponding to the client electronic device. The first electronic device 100 may transmit the first application execution screen 191 executing the first application A to the seventh electronic device 700 as the first shared data. Further, the first electronic device 100 may transmit the second application execution screen 192 executing the second application B to the eighth electronic device 800 as the second shared data. Accordingly, a first application execution screen 711 executing the first application A may be displayed on a screen 790 of the seventh electronic device 700 and a second application execution screen 812 executing the second application B may be displayed on a screen 890 of the eighth electronic device 800. Particularly, on the contrary to the first application execution screen 191 partially displayed on the screen 190 of the first electronic device 100, the seventh electronic device 700 may display the second application execution screen 711 executing all the first application A on the screen 790.

As described above, the host electronic device may share the application with the client electronic device according to various embodiments. Particularly, the host electronic device may receive shared data from another host electronic device and then share the received shared data with the client electronic device. The first electronic device 100 may preset a group of client electronic devices to be connected with the first electronic device 100. Further, the first electronic device 100 may preset an application to be shared corresponding to a client electronic device to be connected with the first electronic device 100.

Hereinafter, a method in which the host electronic device recognizes the screen will be described.

FIGS. 7A and 7B illustrate a coordinate setting method of a host electronic device according to an embodiment of the present disclosure. In FIGS. 7A and 7B, it is assumed that the first electronic device 100 is the host electronic device and the second electronic device 200 is the client electronic device.

Referring to FIG. 7A, it is assumed that the first electronic device 100 corresponding to the host electronic device includes a display having a size of 600 horizontal pixels and 900 vertical pixels, that is, the screen 190. Further, it is assumed that the second electronic device 200 corresponding to the client electronic device includes a display having a size of 1200 horizontal pixels and 800 vertical pixels, that is, the screen 290. As described above, the pixel described as a size unit of the displays, that is, the screens 190 and 290 is only an example, and a display size setting unit may be changed to various units other than the pixel unit by those

skilled in the art. Further, the scope of the present disclosure is not limited by the size unit of the screens 190 and 290.

Referring to FIG. 7A, it is assumed that the first electronic device 100 corresponding to the host electronic device forms a connection with the second electronic device 200 corresponding to the client electronic device. As described above, the host electronic device may receive device information corresponding to the client electronic device from the client electronic device while forming the connection with the client electronic device. Accordingly, it is noted through the device information that the first electronic device 100 in FIG. 7A has a display of a size corresponding to 1200 horizontal pixels and 800 vertical pixels, which is implemented by the screen 290 of the second electronic device 200.

In an embodiment, the first electronic device 100 may set a display coordinate of the first electronic device 100 and a display coordinate of the second electronic device 200 based on the device information of the second electronic device 200. At this time, the first electronic device 100 may assign an independent coordinate to each of the first electronic device 100 and the second electronic device 200.

Referring to FIG. 7A, the first electronic device 100 assigns a coordinate of (0, 0, 1) to a lower left end of the screen 190 of the first electronic device 100, a coordinate of (600, 0, 1) to a lower right end of the screen 190, a coordinate of (0, 900, 1) to an upper left end of the screen 190, and a coordinate of (600, 900, 1) to an upper right end of the screen 190. Two first digits of the coordinate may refer to an x-axis coordinate and a y-axis coordinate on the screen 190 of the first electronic device 100. Further, one last digit may be an electronic device identification number, and it is assumed that an identification number of the first electronic device 100 corresponding to the host electronic device is "1".

The first electronic device 100 corresponding to the host electronic device assigns a coordinate of (0, 0, 2) to a lower left end of the screen 290 of the second electronic device 200 corresponding to the client electronic device, a coordinate of (1200, 0, 2) to a lower right end of the screen 290 of the second electronic device, a coordinate of (0, 800, 2) to an upper left end of the screen 290 of the second electronic device 200, and a coordinate of (1200, 800, 2) to an upper right end of the screen 290 of the second electronic device 200. Two first digits of the coordinate may refer to an x-axis coordinate and a y-axis coordinate on the screen 290. Further, one last digit may be an electronic device identification number, and it is assumed that an identification number of the second electronic device 200 corresponding to the client electronic device is "2".

In an embodiment shown in FIG. 7B, the first electronic device 100 corresponding to the host electronic device may assign one coordinate system to the first electronic device 100 and the second electronic device 200 corresponding to the client electronic device. In FIG. 7B, the first electronic device 100 assigns a coordinate of (0, 0) to a lower left end of the screen 190 of the first electronic device 100, a coordinate of (600, 0) to a lower right end of the screen 190, a coordinate of (0, 900) to an upper left end of the screen 190, and a coordinate of (600, 900) to an upper right end of the screen 190. Two digits of the coordinate may refer to an x-axis coordinate and a y-axis coordinate on the screen 190.

The first electronic device 100 assigns a coordinate of (600, 0) to a lower left end of the screen 290 of the second electronic device 200 corresponding to the client electronic device, a coordinate of (1800, 0) to a lower right end of the screen 290 of the second electronic device, a coordinate of

(600, 800) to an upper left end of the screen 290 of the second electronic device 200, and a coordinate of (1800, 800) to an upper right end of the screen 290 of the second electronic device 200. Two digits of the coordinate may refer to an x-axis coordinate and a y-axis coordinate on the screen 290.

As described above, the first electronic device 100 may set an x-axis coordinate of a start point of the screen 290 of the second electronic device 200 as 600. Accordingly, the first electronic device 100 may assign coordinates which can create an effect as if the screen 290 of the second electronic device 200 is located at a right side of the screen 190 of the first electronic device 100. That is, the first electronic device 100 may assign coordinates such that the screen 290 of the second electronic device 200 has directivity. When the coordinates are assigned as described above, the coordinate (600, 0) of the lower right end of the first electronic device 100 and the coordinate (600, 0) of the lower left end of the second electronic device 200 may be the same. An embodiment may create an effect of using one display by making a setting such that the coordinates of the display of the host electronic device are continuous to the coordinates of the display of the client electronic device. That is, in an embodiment, the screen 190 of the first electronic device 100 and the screen 290 of the second electronic device 200 are connected to each other, and thus may operate as one display.

Assigning the coordinates as if the screen 290 of the second electronic device 200 corresponding to the client electronic device is located at the right side of the screen 190 of the first electronic device 100 corresponding to the host electronic device is only an example. The first electronic device 100 corresponding to the host electronic device may assign coordinates to each of the client electronic devices including the second electronic device 200 as well as the first electronic device 100 in consideration of various directivities of up/down/left/right directions. Accordingly, the first electronic device 100 corresponding to the host electronic device may recognize the screen of the second electronic device 200 corresponding to the client electronic device as a screen expanded from the screen of the first electronic device 100.

An application sharing manager defined by a framework of the first electronic device 100 corresponding to the host electronic device may assign coordinates to the screen 190 of the first electronic device 100 and the screen 290 of the second electronic device 200 corresponding to the client electronic device and manage the coordinates.

FIG. 8 is a flowchart illustrating a control method of a host electronic device according to an embodiment of the present disclosure. In FIG. 8, it is assumed that the first electronic device 100 is the host electronic device and the second electronic device 200 is the client electronic device.

Referring to FIG. 8, the first electronic device 100 first determines an application to be shared in operation S802. When the application to be shared, the first electronic device 100 executes the corresponding application to be shared in operation S804 and performs a surface fling operation on the corresponding application in operation S806. As the surface fling operation is performed as described above, the first electronic device 100 may generate shared data to be transmitted to the second electronic device 200 corresponding to the client electronic device. In an embodiment, the first electronic device 100 may first generate display data including an execution screen executing an application shared with the second electronic device 200 as the shared data. In various embodiments, the first electronic device 100 may

extract the display data before composing the display data with other display data such as, for example, background screen or other application display data.

In various embodiments, the first electronic device **100** may control internal information of the execution screen of the application to be shared, as the surface fling operation of the application to be shared in operation **S808**. The first electronic device **100** may control internal information of an application execution screen to be shared, in accordance with the device information of the client electronic device, for example, the second electronic device **200**. For example, when the second electronic device **200** is a PC, the first electronic device **100** may convert a version of the application to be shared to a version of the PC or converts a resolution of the application execution screen to be shared to the version of the PC. In various embodiments, when a resolution of the second electronic device **200** is different from a resolution of the first electronic device **100**, the first electronic device **100** may convert the resolution of the application execution screen to be shared to the resolution of the second electronic device **200**.

Further, although FIG. **8** illustrated operation **S808**, the control of the internal information in operation **S808** can be omitted according to another embodiment. For example, when the first electronic device **100** and the second electronic device **200** are the same device, the internal control process may be omitted.

Thereafter, the first electronic device **100** generates shared data in operation **S810**. The first electronic device **100** may generate the execution screen of the application to be shared or the application screen in which internal information of the execution screen of the application to be shared is controlled, as the shared data. According to an embodiment of the present disclosure, the first electronic device **100** may generate the shared data by combining the execution screen having the controlled internal information with a voice or vibration multimedia output. That is, the shared data may include the voice or vibration multimedia data as well as the execution screen of the application to be shared. When the shared data is generated in operation **S810**, the first electronic device **100** transmits the shared data to the second electronic device **200** in operation **S812**. Although an embodiment has been described in which the first electronic device **100** generates the shared data to be transmitted to the second electronic device **200** corresponding to the client electronic device by performing the surface fling operation for the application to be shared, there may be several methods in which the host electronic device generates the shared data to be shared with the client electronic device according to another embodiment. For example, the first electronic device **100** may generate the shared data by mirroring the screen **190**.

Further, according to another embodiment, a screen or an application may be shared between the host electronic device and the client electronic device through the use of a Remote Frame Buffer (RFB) or the like. Accordingly, the host electronic device may generate control information allowing the application to be shared to be executed in the client electronic device and transmit the control information to the client electronic device.

FIG. **9** is a flowchart illustrating a control method of a host electronic device and a client electronic device according to an embodiment of the present disclosure. FIGS. **10A** and **10B** illustrate an example in which the host electronic device and the client electronic device of FIG. **9** share shared data according to an embodiment of the present disclosure. For convenience of the description, in FIGS. **9**, **10A**, and **10B**,

it is assumed that the first electronic device **100** is the host electronic device and the second electronic device **200** is the client electronic device.

Referring to FIG. **9**, the host electronic device, that is, the first electronic device **100** executes an application to be shared in operation **S902** and generates shared data in operation **S904**. The first electronic device **100** transmits the generated shared data to the client electronic device, that is, the second electronic device **200** in operation **S906**. In operation **S908**, the second electronic device **200** outputs the shared data received from the first electronic device **100** in operation **S906**. Referring to FIGS. **10A** and **10B**, the first electronic device **100** may execute a gallery application and a map application to display a first execution screen **1001** executing the gallery application and a second execution screen **1002** executing the map application on the screen **190**. Further, the first electronic device **100** may share the map application with the second electronic device **200** by transmitting the shared data to the second electronic device **200**. In an embodiment, the shared data may be at least one of the first execution screen **1001** executing the gallery application and the second execution screen **1002** executing the map application. In FIG. **10A**, the second electronic device **200** may receive the shared data including the second execution screen **1002** from the first electronic device **100**. Accordingly, the second electronic device **200** displays a second execution screen **1012** executing the map application on the screen **290**.

Thereafter, a user command may be input into the second electronic device **200** in operation **S910**. In various embodiments, when the second electronic device **200** receives the shared data, the second electronic device **200** may generate a dummy window for outputting the shared data. In an embodiment, when the user command is input into the client electronic device, that is, the second electronic device **200**, the “dummy window” may be a window displayed on the client electronic device (for example, the second electronic device **200**) to transmit the user command to the host electronic device, that is, the first electronic device **100**. In an embodiment, the user command, for example, a drag gesture, may be input into the second electronic device **200** through the dummy window. The second electronic device **200** may transmit information, such as an input coordinate of the screen **290** into which the drag gesture is input, an input time, and a type of an input gesture, to the first electronic device **100**.

Referring to FIG. **10A**, a user **1** inputs a pinch-in gesture **1020** into the second electronic device **200** through the screen **290** as a user input. The pinch-in gesture **1020** is a gesture of reducing a distance between a first touch point **1020a** and a second touch point **1020b** of the screen **290** by the user **1**. That is, in FIG. **10A**, the user **1** inputs the pinch-in gesture of reducing the distance between a thumb and an index finger into the screen **290** as the user input by closing the distance between the thumb touching the first touch point **1020a** of the screen **290** and the index finger touching the second touch point **1020b**.

Referring to FIG. **10A** again, the second electronic device **200** receives the second execution screen **1002** from the first electronic device **100** as the shared data and may display the second application execution screen **1012** executing the map application on the screen **290**. In various embodiments, the second electronic device **200** may generate and place the dummy window on the second execution screen **1012** executing the map application. Further, the second electronic device **200** may make a control such that the dummy window is not displayed on the screen **290** by adjusting

transparency of the dummy window. That is, after generating the dummy window through which the user command is input, the second electronic device 200 may make the dummy window transparent and place the dummy window on the window 1012 outputting the application to be shared.

FIG. 10B illustrates the first electronic device 100 and the second electronic device 200 after the pinch-in gesture is input into the second electronic device 100 of FIG. 10A as the user input. Referring to FIG. 10B, the second electronic device 200 may make a control such that the second execution screen 1013 executing the map application is displayed on the screen 290. Further, in various embodiments, the pinch-in gesture 1020 input by the user 1 may be input into the dummy window, not the second execution screen 1012 executing the map application. As described above, when the pinch-in gesture 1020 is input into the dummy window of the second electronic device 200, the second electronic device 200 may transmit the pinch-in gesture 1020 or data related to the pinch-in gesture 1020 to the first electronic device 100 as user command information. The second electronic device 200 may transmit user command information including at least one of an input coordinate on the screen 290 into which the pinch-in gesture 1020 is input, an input time, and a type of an input gesture to the first electronic device 100 as the data related to the pinch-in gesture 1020. As described above, the second electronic device 200 transmits the user command information to the first electronic device 100 in operation S912.

Referring to FIG. 9, the first electronic device 100 receives the user command information from the second electronic device 200 and inputs the user command information received from the second electronic device 200 to the application to be shared in operation S914. As described above, in an embodiment, the user input made into the second electronic device 200 corresponding to the client electronic device may be performed as the user input of the first electronic device 100 executing the application to be shared.

The first electronic device 100 outputs a corresponding event as a result of the input of the user command information into the application to be shared in operation S916. For example, in an embodiment of FIG. 10B, the first electronic device 100 may input the pinch-in gesture 1020 corresponding to the user command information received from the second electronic device 200 into the map application corresponding to the application to be shared, as the user input. In an embodiment, it is assumed that the map application is set to provide a zoomed-out map as an operation corresponding to the pinch-in gesture 1020. Referring to FIGS. 10A and 10B, the first electronic device 100 inputs the pinch-in gesture 1020 into the map application. The map application may perform the operation corresponding to the pinch-in gesture 1020. It is assumed that the operation of the map application corresponding to the pinch-in gesture 1020 zooms-out the map currently displayed on the screen 190.

The first electronic device 100 may control the map application such that the map currently displayed on the screen 190 is zoomed-out in response to the pinch-in gesture 2030 input through the second electronic device 200. Accordingly, as illustrated in FIG. 10B, the third execution screen 1003 having the map which is more zoomed-out than the map of the second execution screen 1002 may be displayed on the screen 190 of the first electronic device 100.

Referring back to FIG. 9, since the event corresponding to the user command information has been output in operation S916, the first electronic device 100 generates shared data again in operation S918. When the shared data is generated

again, the first electronic device 100 transmits the shared data to the second electronic device 200 in operation S920.

The second electronic device 200 having received the shared data from the first electronic device 100 in S920 outputs the shared data in operation S922. For example, referring to FIG. 10B, the second electronic device 200 may receive the third execution screen 1003 displayed on the first electronic device 100 from the first electronic device 100 as the shared data. Since the third execution screen 1003 has the map zoomed-out from the map displayed on the second execution screen 1002 of FIG. 10A, the second electronic device 200 may display the third execution screen 1013 having a map zoomed-out from a map displayed on the second execution screen 1012 on the screen 290, like the third execution screen 1003.

FIG. 11 is a flowchart illustrating a method in which a host electronic device and a client electronic device share data according to an embodiment of the present disclosure.

Referring to FIG. 11, it is assumed that the first electronic device 100 is the host electronic device and the second electronic device 200 is the client electronic device. The first electronic device corresponding to the host electronic device executes an application in operation S1102. When the application is executed, the first electronic device 100 changes internal information of the application in operation S1104. Thereafter, the first electronic device 100 generates shared data to be shared with the second electronic device 200 in operation S1106. In an embodiment, the first electronic device 100 may change internal information of an execution screen executing an application which is being shared with the second electronic device 200, that is, an application to be shared and generate shared data. The first electronic device 100 transmits the shared data to the second electronic device 200 in operation S1108.

The second electronic device 200 receives the shared data received from the first electronic device 100 corresponding to the host electronic device in operation S1108. The second electronic device 200 may display and output the shared data received from the first electronic device 100 on the screen 290 in operation S1110. Thereafter, the second electronic device 200 receives a user command from the user in operation S1112 and transmits user command information corresponding to the user input to the first electronic device 100 in operation S1114.

For example, the second electronic device 200 may receive a user input corresponding to touching one point of the screen 290 from the user. Further, as described above, the second electronic device 200 transmits user command information (for example, a coordinate of the point where the user input is performed) corresponding to the user input made into the second electronic device 200 to the first electronic device 100, so that the first electronic device 100 can perform an operation according to the user input.

The first electronic device 100 converts the user command information received from the second electronic device 200 such that the user command information can be applied to the first electronic device 100 in operation S1116. In various embodiments, the first electronic device 100 may convert the user command information based on the change in the internal information in operation S1104. For example, the resolution of the first electronic device 100 and the resolution of the second electronic device 200 may be different from each other. When the resolutions are different from each other, even a user input for selecting the same object has a different input coordinate according to the device. For example, when it is assumed that a coordinate of a particular object is (350, 50) in the first electronic device 100, a

coordinate in the second electronic device 200 may be (700, 160). The first electronic device 100 may change the internal information by switching the coordinate (350, 50) to the coordinate (700, 160) in operation S1104. Further, the user command information received from the second electronic device 200 may be converted based on the change in the internal information by switching the coordinate (700, 160) to the coordinate (350, 50) in operation S1116.

The first electronic device 100 inputs the converted user command information into the application in operation S1118. The application of the first electronic device 100 may receive the converted user command information and output an event corresponding to the user command information. When the event corresponding to the user command information is output from the application in operation S1120, the first electronic device 100 generates shared data corresponding to the event in operation S1122. The first electronic device 100 transmits the shared data corresponding to the event to the second electronic device 200 in operation S1124. The second electronic device 200 receives the shared data from the first electronic device 100 as a result of the user command of operation S1112 in S1124. The second electronic device 200 outputs the shared data in operation S1126.

FIG. 12 is a flowchart illustrating a method in which a host electronic device and a client electronic device share data according to an embodiment of the present disclosure.

Referring to FIG. 12, it is assumed that the first electronic device 100 is the host electronic device and the second electronic device 200 is the client electronic device.

The first electronic device 100 corresponding to the host electronic device executes an application which is being shared with the second electronic device 200 in operation S1202. When the application is executed, the first electronic device 100 generates shared data to be shared with the second electronic device 200 in operation S1204. When the shared data is generated, the first electronic device 100 transmits the shared data to the second electronic device 200 in operation S1206.

The second electronic device 200 having received the shared data from the first electronic device 100 changes internal information of the shared information in operation S1208. The second electronic device 200 according to an embodiment may change the internal information of the shared data to output the shared data received from the first electronic device 100. The second electronic device 200 according to an embodiment may change the internal information of the shared data received from the first electronic device 100 by converting the shared data to have a format which can be output by the second electronic device 200.

The second electronic device 200 outputs the shared data having the changed internal information in operation S1210. In operation 1210, the screen 290 of the second electronic device 200 may display the shared data converted to have the format which can be output by the second electronic device 200.

Thereafter, a user command may be input into the second electronic device 200 by the user in operation S1212. For example, a user input of touching one point of the screen 290 may be input into the second electronic device 200 by the user.

The second electronic device 200 converts the user command in accordance with the change in the internal information in operation S1214. In operation 1214, the second electronic device 200 according to an embodiment may convert the user command in accordance with the change in the internal information by converting the user command

input in operation S1212 to have a format which can be read by the first electronic device 100. For example, the second electronic device 200 may coordinate-convert user command information (for example, a coordinate of a point on the screen 290 where the user input is made) corresponding to the user input made in the second electronic device 200 to be applicable to the application of the first electronic device 100.

The second electronic device 200 transmits the converted user command information to the first electronic device 100 in operation S1216. The first electronic device 100 inputs the converted user command information to the application in operation S1218. The application of the first electronic device 100 may receive the converted user command information and output an event corresponding to the user command information. When the event corresponding to the user command information is output from the application in operation S1220, the first electronic device 100 generates shared data corresponding to the event in operation S1222. The first electronic device 100 transmits the shared data corresponding to the event to the second electronic device 200 in operation S1224. In operation S1224, the second electronic device 200 receives the shared data from the first electronic device 100 as a result of the user command of operation S1212. The second electronic device 200 outputs the shared data in operation S1226. In various embodiments, the second electronic device 200 may change internal information of the shared data received from the first electronic device 100 in operation S1224 and output the converted shared data having the changed internal information in operation S1226.

FIGS. 13A, 13B, and 13C illustrate a method in which a host electronic device and a client electronic device share shared data according to an embodiment of the present disclosure.

Referring to FIG. 13A, the first electronic device 100 may include a display having 600 horizontal pixels and 900 vertical pixels, that is, the screen 190. The second electronic device 200 may include a display having 1200 horizontal pixels and 800 vertical pixels, that is, the screen 290. The pixel described as a size unit of the displays, that is, the screens 190 and 290 is only an example, and a display size setting unit may be changed to various units other than the pixel unit by those skilled in the art. Further, the scope of the present disclosure is not limited by the size unit of the screens 190 and 290.

Referring to FIG. 13A, the first electronic device 100 displays a first execution screen 1301 executing a gallery application on an upper side of the screen 190 and a second execution screen 1302 executing a map application on a lower side of the screen 190. In an embodiment of FIG. 13A, the first electronic device 100 may set separate coordinates corresponding to each of the first electronic device 100 and the second electronic device 200. The first electronic device 100 may display an execution screen of the map application, that is, the second execution screen 1302 on a rectangular area having four edges of coordinates (0, 0, 1), (0, 450, 1), (600, 0, 1), and (600, 450, 1).

The first electronic device 100 may change internal information such that the second execution screen 1302 is displayed on an entire surface of the screen 290 of the client electronic device 200. For example, in the embodiment of FIG. 13A, the first electronic device 100 corresponding to the host electronic device horizontally enlarges a size of the second execution screen 1302 twice and vertically enlarges the size of the second execution screen 1302 16/5 times.

The first electronic device 100 may generate shared data having the changed internal information of the second execution screen 1302. The first electronic device 100 may transmit the shared data having the changed internal information to the second electronic device 200 corresponding to the client electronic device. The second electronic device 200 may display the shared data received from the first electronic device 100 on the screen 290. As illustrated in FIG. 13A, the second electronic device 200 may display the shared data having the changed internal information, that is, a second execution screen 1312 with a size of 1200×800. As described above, in FIG. 13A, the first electronic device 100 may allow the second execution screen 1302 to be applied to the resolution of the second electronic device 200 through the change in the internal information.

Referring to FIG. 13A, the second electronic device 200 receives a user command. The user 1 may click a position corresponding to “A-Pizza” of the second execution screen 1312 as indicated by a reference numeral 1010. More specifically, the user 1 may touch a point of (700, 160) of the screen 290. At this time, the touch may be input into the first electronic device 100 or the second electronic device 200 as a user command. Further, the user command may be transmitted to the first electronic device 100 by the second electronic device 200 as user command information.

The second electronic device 200 may transmit the user command information to the first electronic device 100. For example, the second electronic device 200 may transmit information indicating that a touch gesture 1332 has been input into the point (700, 160) of the display 290 by the user 1 to the first electronic device 100.

The first electronic device 100 may convert the user command information in accordance with the change in the internal information. In FIG. 13A, the first electronic device 100 may change the internal information by horizontally enlarging a size of the second execution screen 1302 executing the map application corresponding to the application to be shared twice and vertically enlarging the size of the second execution screen 1302 16/5 times. Further, in an embodiment, the first electronic device 100 may convert the user command information received from the second electronic device 200 by multiplying horizontal and vertical coordinates by 1/2 and 5/16 which are reciprocal numbers of the enlargement ratios according to the user command information.

Referring to FIG. 13B, the first electronic device 100 may change a touch gesture input 1331 on the point (700, 160) corresponding to the user command information to a touch gesture 1331 input on the point (350, 50) generated by multiplying the horizontal coordinate and the vertical coordinate by 1/2 and 5/16, respectively in accordance with the change in the internal information.

The first electronic device 100 may input the touch gesture 1331 on the point (350, 50) corresponding to the converted user command information into the application to be shared, for example, the map application of FIGS. 13A and 13B. The first electronic device 100 may output an event corresponding to the converted user command information and generate shared data. The first electronic device 100 may transmit the shared data to the second electronic device 200 and output the shared data received from the first electronic device 100 through, for example, the screen 290.

For example, the first electronic device 100 may determine that the touch gesture 1331 has been input on an object of “A-Pizza” in response to the user command information. The first electronic device 100 may input the touch gesture 1331 into the map application as the user command.

Referring to FIG. 13C, the first electronic device 100 may display a third execution screen 1041 including information regarding “A-Pizza” on the screen 190 as the event corresponding to the user command. The first electronic device 100 may transmit the third execution screen 1041 to the second electronic device 200 as the shared data and the second electronic device 200 may display a third execution screen 1042. In various embodiments, the second electronic device 200 may change internal information of the third execution screen 1041 received from the first electronic device 100 to generate the third execution screen 1042 and output the generated third execution screen 1042 through the screen 290.

FIG. 14 illustrates a system architecture of a host electronic device according to an embodiment of the present disclosure.

Referring to FIG. 14, a multi window manager 1411, an application share manager 1412, and a frame buffer 1413 may be defined in a framework 1410 of the host electronic device. The multi window manager 1411 may manage sizes, transparency, positions, dpi, and resolutions of a plurality of windows corresponding to a plurality of applications executed by the client electronic device. One or more activities 1401 to 1404 may load an API from the multi window manager 1411 and process the loaded API. The multi window manager 1411 may provide callback. The multi window manager 1411 may make a management such that one or more activities 1401 to 1404 are displayed on the host electronic device.

The multi window manager 1411 may provide the application to be shared to the application share manager 1412 and the application share manager 1412 may transmit shared data of the application to be shared to a client electronic device 1450. Alternatively, the application share manager 1412 may directly receive the application to be shared and transmit the received application.

The frame buffer 1413 may temporarily store the shared data to be transmitted. The application share manager 1412 may transmit an application screen based on various communication schemes such as WiFi, 3G/4G data communication, Bluetooth and the like. The client electronic device 1450 may display a received application screen 1451.

When the client electronic device 1450 receives an event from the user, the client electronic device 1450 may transmit the received event to the application share manager 1412. The application share manager 1412 may output the received event to the corresponding activities 1401 to 1404.

FIG. 15 illustrates layers in a host electronic device and a client electronic device according to an embodiment of the present disclosure.

Referring to FIG. 15, a host electronic device 1500 may execute and display a first application execution screen 1501. The host electronic device 1500 may define an application layer 1551, an application framework layer 1552, an application sharing service layer 1553, a surface controller layer 1554, a network interface 1555, a framework layer 1556, and a driver 1557. For example, the first application A may be executed in the application layer 1551. The application framework layer 1552 may be an interface of the application layer 1551. The application sharing service layer 1553 may receive, for example, data of the first application A interfaced through the application framework layer 1552.

The application sharing service layer 1553 may allow the framework 1556 to transmit a surface of the corresponding application to the surface controller 1554 as the shared data. The network interface 1555 may transmit the surface of the corresponding application to a network interface 1565 of the

client electronic device **1510**. The framework **1556** may provide the API or callback and the driver **1557** may control hardware.

The network interface **1565** of the client electronic device **1510** may receive, for example, a surface of the first application A as the shared data shown on application execution screen **1511**, adjacent to screen **1512**. The surface controller **1564** of the framework **1566** may process contents of the received surface and transmit the processed surface to the application sharing service layer **1563**. The application sharing service layer **1563** transmits the received surface to the application framework layer **1562** to output the surface by using an application, such as a viewer only for the shared data. The application framework layer **1562** transmits the received surface to an application **1561**, such as a viewer only for the shared data, to output the surface. The application, such as the viewer only for the shared data, receives an event from the user and transmits the event to the application framework layer **1562**. The application framework layer **1562** may transmit the input event to the application sharing service layer **1563** and the application sharing service layer **1563** may transmit the event to the host electronic device **1500** through the network interface **1565**. The framework layer **1566** may provide the API or callback and the driver **1567** may control hardware.

FIG. **16** illustrates a method in which a host electronic device and a client electronic device share shared data according to an embodiment of the present disclosure.

Referring to FIG. **16**, a first electronic device E1 **1610** is connected with a second electronic device E2 **1620** and a third electronic device E3 **1630**. In an embodiment, it is assumed that the first electronic device **1610** is the host electronic device and the second electronic device **1620** and the third electronic device **1630** are the client electronic devices with respect to the first electronic device **1610**.

Referring to FIG. **16**, an execution screen of an application G currently executed by the first electronic device **1610** is displayed on a screen **1611** of the first electronic device **1610**. The screen **1611** may display a list **1612** of applications A, B, C, D, E, and F which can be executed by the first electronic device **1610** on a left side of the screen **1611** and a list **1613** of the electronic devices E2 and E3 connected with the first electronic device **1610** on a right side of the screen **1611**. The user **1** using the first electronic device **1610** may select one of the applications A, B, C, D, E, and F included in the list **1612** and make a drag input of dragging the selected application to the electronic devices E2 and E3 included in the list **1613**, in the first electronic device **1610**, so as to share the applications A, B, C, D, E, and F with other electronic devices E2 and E3.

Referring to FIG. **16**, the user **1** selects the application A from the list **1612** and drags the application A to the second electronic device E2, and selects the applications C and D and drags the applications C and D to the third electronic device E3. Further, it is assumed that the second electronic device **1620** is executing an application H. The second electronic device **1620** shares the application A with the first electronic device **1610** while executing the application H. Accordingly, an execution screen of the application A and an execution screen of the application H may be displayed on a screen **1621** of the second electronic device **1620**. Further, execution screens of the applications C and D may be displayed on a screen **1631** of the third electronic device **1630** sharing the applications C and D with the first electronic device **1610**.

According to another embodiment, a shared application may be an application which is not being executed by the

first electronic device **1610**. That is, in an embodiment, the first electronic device **1610** may control the second electronic device **1620** or the third electronic device **1630** such that the second electronic device **1620** or the third electronic device **1630** executes an application which is not being executed in the first electronic device **1610** according to a drag input.

FIG. **17** illustrates a method in which a host electronic device and a client electronic device share shared data according to an embodiment of the present disclosure.

Referring to FIG. **17**, a first electronic device E1 **1710** is connected with a second electronic device E2 **1720**, the second electronic device E2 **1720** is connected with the first electronic device E1 **1710** and a third electronic device E3 **1730**, and the third electronic device E3 **1730** is connected with the second electronic device E2 **1720**. In an embodiment, it is assumed that the first electronic device **1710** and the second electronic device are the host electronic devices, the second electronic device **1720** is the client electronic device of the first electronic device **1710** and the host electronic device of the third electronic device **1730**, and the third electronic device **1730** is the client electronic device of the second electronic device **1720**.

Referring to FIG. **17**, the execution screen of the application G currently executed by the first electronic device **1710** is displayed on a screen **1711** of the first electronic device **1710**. The screen **1711** may display a list **1710** of applications A, B, C, D, E, and F which can be executed by the first electronic device **1712** on a left side of the screen **1711** and a list **1713** of the electronic device E2 connected with the first electronic device **1710** on a right side of the screen **1711**. Also, the second electronic device **1720** may display a list **1723** of the electronic devices E1 and E3 connected with the second electronic device **1720** on a right side of a screen **1721**. Similarly, the third electronic device **1730** may display a list **1733** of the electronic device E2 connected with the third electronic device **1730** on a right side of a screen **1731**.

In various embodiments, the user **1** using the first electronic device **1710** may select one of the applications A, B, C, D, E, and F included in the list **1712** and make a drag input of dragging the selected application to the electronic device E2 included in the list **1713**, in the first electronic device **1713**, so as to share the applications A, B, C, D, E, and F with another electronic device E2.

Referring to FIG. **17**, the user **1** selects the application A from the list **1712** and drags the application A to the second electronic device **1720**. At this time, it is assumed that the second electronic device **1720** is executing the application H. The second electronic device **1720** shares the application A with the first electronic device **1710** while executing the application H. Accordingly, the execution screen of the application A and the execution screen of the application H may be displayed on the screen **1721** of the second electronic device **1720**.

The user **1** using the first electronic device **1710** may select the application C from the list **1712** and drag the application C to the third electronic device E3 connected with the second electronic device **1720**. At this time, it is assumed that the third electronic device **1730** is executing an application I. The drag input by the user having selected the application C may be transferred to the second electronic device **1720** connected with the first electronic device **1710**. The second electronic device **1720** may allow the third electronic device **1730** to execute the application C by controlling the third electronic device **1730** in accordance with the drag input. Accordingly, execution screens of the

31

applications C and I may be displayed on a screen 1731 of the third electronic device 1730.

FIG. 18 illustrates a method in which a host electronic device and an accessory device share shared data according to an embodiment of the present disclosure.

Referring to FIG. 18, it is assumed that a first electronic device E1 1810 is the host electronic device of a second electronic device E2 1820 and the second electronic device 1820 is the client electronic device of the first electronic device 1810. Further, in FIG. 18, the client electronic device, that is, the second electronic device 1820 may be an accessory device of the host electronic device.

Referring to FIG. 18, the execution screen of the application B currently executed by the first electronic device 1810 is displayed on a screen 1811 of the first electronic device 1810. The screen 1811 may display a list 1812 of applications A, B, C, D, E, F, G, and H which can be executed by the first electronic device 1810 on a left side of the screen 1811 and a list 1813 of the electronic devices E2 and E3 connected with the first electronic device 1810 on a right side of the screen 1811.

Referring to FIG. 18, the first electronic device 1810 may be connected with accessory devices as the client electronic devices, for example, devices which can be attached to/detached from the host electronic device or can communicate with the host electronic device. The accessory devices may be, for example, display devices such as a TeleVision (TV) and a monitor, a digital clock and the like. In various embodiments, the host electronic device, for example, the first electronic device 1810 may perform a discovery operation to detect devices which are located close to the first electronic device 1810 and can communicate with the first electronic device 1810. The first electronic device 1810 may inform the user 1 of the accessory devices (for example, the display device and the like) detected through the discovery operation and receive a user input for determining whether to connect the first electronic device 1810 with the accessory devices. In an embodiment, the accessory devices refers to devices which can operate as the client electronic device. When the first electronic device 1810 receives the user input for determining to connect the first electronic device 1810 with the accessory devices, the first electronic device 1810 determines the corresponding accessory device as the client electronic device. That is, the host electronic device may recognize the accessory device connected with the host electronic device as the client electronic device. At this time, the host electronic device may receive device information of the accessory device from the accessory device. Further, when the second electronic device 1820 corresponding to the client electronic device is connected with the first electronic device 1810, the second electronic device 1820 operates according to a control of the first electronic device 1810 corresponding to the host electronic device.

As described above, when the first electronic device 1810 is connected with the accessory device, for example, the second electronic device 1820, the second electronic device E2 1820 may be inserted into the list 1813 displayed on the screen 1811. Further, the user 1 according to an embodiment may determine the execution screen of the application A to be displayed on the screen 1821 of the accessory device, that is, the second electronic device 1820 through a drag input as illustrated in FIG. 18.

Referring to FIG. 18, the user 1 selects the application A from the list 1812 and makes a drag input of dragging the application A to the accessory device connected with the first electronic device 1810, that is, the second electronic device 1820, in the first electronic device 1810. The host electronic

32

device according to an embodiment, that is, the first electronic device 1810 may generate shared data to be shared with the accessory device and transmit the shared data to the accessory device as illustrated in FIG. 18. In various embodiments, the host electronic device (for example, the first electronic device 1810) may receive device information of the accessory device from the accessory device (for example, the second electronic device 1820). Further, the host electronic device may generate shared data based on the device information and transmit the shared data to the accessory device, so as to share data with the accessory device. At this time, the device information of the accessory device may include an identification, display size information, resolution information, display information, and voice or vibration multimedia output related information of the accessory device.

The accessory device, for example, second electronic device 1820 shares the application A with the first electronic device 1810. In various embodiments, the second electronic device 1820 may receive the shared data, for example, the execution screen of the application A from the first electronic device 1810 and display the received execution screen on the screen 1821. In various embodiments, the execution screen of the application A may be data generated by the first electronic device 1810 based on the device information of the second electronic device 1820.

Further, the connection between the host electronic device and the client electronic device according to an embodiment can be made through a wired/wireless broad area communication scheme, such as a LAN, a Metropolitan Area Network (MAN), or a Wide Area Network (WAN), as well as a short distance communication scheme, such as NFC, WiFi Direct, Bluetooth, or InfraRed (IR) communication. In addition, the host electronic device or the client electronic device may display a list of connected electronic devices and provide the list to the user. In various embodiments, the host electronic device or the client electronic device may automatically search for connectable electronic devices and provide a result thereof to the user in a list form. The user according to an embodiment may select at least one electronic device included in the list to be connected with the corresponding electronic device. In various embodiments, the connection between the electronic devices may be made in a form of M:1 or M:N (N is a natural number).

Through various embodiments of the present disclosure, an electronic device which can share an application with another electronic device and a control method thereof can be provided. Accordingly, the user may control the electronic device such that the electronic device shares only an application to be shared, not the entirety of the display, with another device. Another electronic device may receive a predetermined command from the user and transmit the command to the electronic device as well as simply displaying the application. The electronic device may input the command received from another electronic device into the application to process the command. Accordingly, the electronic device can cooperate with another electronic device.

It will be appreciated that the various embodiments of the present disclosure may be implemented in a form of hardware, software, or a combination of hardware and software. Any such software may be stored, for example, in a volatile or non-volatile storage device such as a ROM, a memory such as a RAM, a memory chip, a memory device, or a memory IC, or a recordable optical or magnetic medium such as a CD, a DVD, a magnetic disk, or a magnetic tape, regardless of its ability to be erased or its ability to be re-recorded. The various embodiments of the present dis-

closure can be realized by a computer or a portable terminal including a controller and a memory, and it can be seen that the memory corresponds to an example of a machine-readable storage medium which is suitable for storing a program or programs including instructions by which the various embodiments of the present disclosure are realized. Accordingly, the present disclosure includes a program including a code for implementing the apparatus and method described in the appended claims of the specification and a machine (a computer or the like)-readable storage medium for storing the program.

Further, the electronic device can receive the program from a program providing apparatus connected to the device wirelessly or through a wire and store the received program. The program supply apparatus may include a program that includes instructions to execute the various embodiments of the present disclosure, a memory that stores information or the like required for the various embodiments of the present disclosure, a communication unit that conducts wired or wireless communication with the electronic apparatus, and a control unit that transmits a corresponding program to a transmission/reception apparatus in response to the request from the electronic apparatus or automatically.

While the present disclosure has been shown and described with reference to various embodiments thereof, it will be understood by those skilled in the art that various changes in form and details may be made therein without departing from the spirit and scope of the present disclosure as defined by the appended claims and their equivalents.

What is claimed is:

1. A method for sharing data with a client device by a host device, the method comprising:

forming, by using a processor of the host device, a connection with the client device;

receiving, by a transceiver of the host device, device information of the client device from the client device;

displaying, on a first display of the host device, a first portion of a first execution screen of a first application executed on the host device based on device information of the host device, wherein a second portion of the first execution screen is not displayed on the first display;

displaying, on the first execution screen, a first object corresponding to the client device and a second object corresponding to the first application [executed] *currently executing* on the host device for sharing with the client device;

receiving, by using the first display, a first input for dragging the second object toward the first object;

based on receiving the first input, transmitting, by using the transceiver, first data of the first application executed on the host device for displaying the second portion with at least a part of the first portion of the first execution screen on [the] a second display of the client device, to the client device, while continuing to display the first portion on the first display;

receiving, by using the transceiver, information on a coordinate of a second input with respect to the second display from the client device, wherein the information on the coordinate of the second input is transmitted by the client device in response to the second input being detected on the second display;

based on receiving the information on the coordinate of the second input, adjusting the information on the coordinate of the second input based on the device information of the client device and the device information of the host device and displaying, on the first

display, an event based on the adjusted information on the coordinate of the second input; and

transmitting, by using the transceiver, second data of the first application executed on the host device corresponding to the displayed event to the client device, wherein the device information of the client device includes display size information and display resolution information of the client device, and wherein the device information of the host device includes display size information and display resolution information of the host device.

2. The method of claim 1, further comprising: transmitting, by using the transceiver, an application sharing request to the client device.

3. The method of claim 1, wherein the forming of the connection with the client device comprises: receiving, by using the transceiver, an application sharing request from the client device; and transmitting, by using the transceiver, an application sharing permission to the client device.

4. The method of claim 1, wherein the forming of the connection with the client device comprises: if an accessory device is detected, determining, by using the processor, the accessory device as the client device.

5. The method of claim 1, wherein the device information of the client device includes at least one of an identification of the client device, display information, or voice or vibration multimedia output related information.

6. The method of claim 1, further comprising: determining a preset application by default as the first application.

7. The method of claim 1, further comprising: displaying, by using the processor, the first execution screen and a second execution screen of a second application;

detecting a fling of an execution screen between the first execution screen or the second execution screen; and generating, by using the processor, shared data including data in which the execution screen have been subjected to the fling.

8. The method of claim 7, further comprising: generating, by using the processor, the shared data by controlling internal information of the data in which the execution screen have been subjected to the fling based on the device information of the client device and the device information of the host device.

9. The method of claim 1, further comprising: generating, by using the processor, control information for allowing the first application to be executed on the client device.

10. The method of claim 1, further comprising receiving, by an input device of the host device, user command information related to a user command for the client device.

11. A host device for sharing data with a client device, the host device comprising:

a first display;

a transceiver; and

a processor is configured to:

control the transceiver to form a connection with the client device,

receive, by using the transceiver, device information of the client device from the client device,

control the first display to display a first portion of a first execution screen of a first application executed on the host device based on device information of the host device, wherein a second portion of the first execution screen is not displayed on the first display,

35

control the first display to display, on the first execution screen, a first object corresponding to the client device and a second object corresponding to the first application [executed] *currently executing* on the host device for sharing with the client device,

receive, by using the first display, a first input for dragging the second object toward the first object,

based on receiving the first input, control the transceiver to transmit first data of the first application executed on the host device for displaying the second portion with at least a part of the first portion of the first execution screen on [the] a second display of the client device, to the client device, while continuing to display the first portion on the first display,

receive, by using the transceiver, information on a coordinate of a second input with respect to the second display from the client device, wherein the information on the coordinate of the second input is transmitted by the client device in response to the second input being detected on the second display,

based on receiving the information on the coordinate of the second input, adjust the information on the coordinate of the second input based on the device information of the client device and the device information of the host device and control the first display to display an event based on the adjusted information on the coordinate of the second input, and

control the transceiver to transmit second data of the first application executed on the host device corresponding to the displayed event to the client device,

wherein the device information of the client device includes display size information and display resolution information of the client device, and

wherein the device information of the host device includes display size information and display resolution information of the host device.

12. The host device of claim 11, wherein the processor is further configured to:

control the transceiver to transmit an application sharing request to the client device.

13. The host device of claim 11, wherein the processor is further configured to:

receive, by using transceiver, an application sharing request from the client device, and

control the transceiver to transmit an application sharing permission to the client device.

14. The host device of claim 11, wherein the processor is further configured to:

detect an accessory device through a discovery operation, and

determine the accessory device as the client device.

15. The host device of claim 11, wherein the device information of the client device includes at least one of an identification of the client device, display information, or voice or vibration multimedia output related information.

16. The host device of claim 11, wherein the processor is further configured to determine a preset application by default as the first application.

17. The host device of claim 11, wherein the processor is further configured to:

control the first display to display the first execution screen and a second execution screen of a second application,

detect a fling of an execution screen between the first execution screen or the second execution screen, and

generate shared data including data in which the execution screen have been subjected to the fling.

36

18. The host device of claim 17, wherein the processor is further configured to:

generate the shared data by controlling internal information of the data in which the execution screen have been subjected to the fling based on the device information of the client device and the device information of the host device.

19. The host device of claim 11, further comprising an input device,

wherein the processor is further configured to:

receive, by using the input device, user command information related to a user command for the client device.

20. A control method of an electronic device communicating with a first external device and a second external device, the control method comprising:

establishing connections with the first external device and the second external device;

obtaining first resolution information of the first external device and second resolution information of the second external device;

receiving a first input for designating a first execution screen of a first application to be displayed on the first external device, wherein the first application is an application which is not currently executed by the electronic device;

receiving a second input for designating a second execution screen of a second application to be displayed on the second external device, wherein the second application is an application which is not currently executed by the electronic device;

based on receiving a third input for the first application: executing the first application exclusively on the electronic device,

generating first data related to the executed first application based on the obtained first resolution information, and

based on the first execution screen of the first application being designated to be displayed on the first external device, transmitting, to the first external device, the first data for displaying a first execution screen of the first application on the first external device; and

based on receiving a fourth input for the second application:

executing the second application exclusively on the electronic device,

generating second data related to the executed second application based on the obtained second resolution information, and

based on the second execution screen of the second application being designated to be displayed on the second external device, transmitting, to the second external device, the second data for displaying a second execution screen of the second application on the second external device.

21. The control method of claim 20, wherein, the first application is executed based on designating the first application, and the second application is executed based on designating the second application.

22. The control method of claim 20,

wherein, based on executing the first application, the first execution screen of the first application is displayed on the first external device without displaying the first execution screen on the electronic device, and

wherein, based on executing the second application, the second execution screen of the second application is

displayed on the second external device without displaying the second execution screen on the electronic device.

23. The control method of claim 20, wherein, the first input for designating the first application to be displayed on the first external device is received via a touch screen of the electronic device, and wherein the second input for designating the second application to be displayed on the second external device is received via the touch screen.

24. An electronic device communicating with a first external device and a second external device, the electronic device comprising:

a touch screen;
communication circuitry; and
a processor configured to:

establish connections with the first external device and the second external device;

obtain first resolution information of the first external device and second resolution information of the second external device;

receive a first input for designating a first execution screen of a first application to be displayed on the first external device, wherein the first application is an application which is not currently executed by the electronic device;

receive a second input for designating a second execution screen of a second application to be displayed on the second external device, wherein the second application is an application which is not currently executed by the electronic device;

based on receiving a third input for the first application:

execute the first application exclusively on the electronic device,

generate first data related to the executed first application based on the obtained first resolution information, and

based on the first execution screen of the first application being designated to be displayed on the first external device, transmit, to the first external device by using the communication circuitry, the first data for displaying a first execution screen of the first application on the first external device; and

based on receiving a fourth input for the second application:

execute the second application exclusively on the electronic device,

generate second data related to the executed second application based on the obtained second resolution information, and

based on the second execution screen of the second application being designated to be displayed on the second external device, transmit, to the second external device, the second data for displaying a second execution screen of the second application on the second external device.

25. The electronic device of claim 24, wherein, the first application is executed based on designating the first application, and the second application is executed based on designating the second application.

26. The electronic device of claim 24,

wherein, based on executing the first application, the first execution screen of the first application is displayed on the first external device without displaying the first execution screen on the electronic device, and

wherein, based on executing the second application, the second execution screen of the second application is displayed on the second external device without displaying the second execution screen on the electronic device.

27. The electronic device of claim 24, wherein, the first input for designating the first application to be displayed on the first external device is received via the touch screen of the electronic device, and

wherein the second input for designating the second application to be displayed on the second external device is received via the touch screen.

28. A non-transitory computer-readable storage medium having stored thereon instructions which, when executed by at least one processor of an electronic device, cause the electronic device to perform at least one operation, the at least one operation comprising:

establishing connections with a first external device and a second external device;

obtaining first resolution information of the first external device and second resolution information of the second external device;

receiving a first input for designating a first execution screen of a first application to be displayed on the first external device, wherein the first application is an application which is not currently executed by the electronic device;

receiving a second input for designating a second execution screen of a second application to be displayed on the second external device, wherein the second application is an application which is not currently executed by the electronic device;

based on receiving a third input for the first application: executing the first application exclusively on the electronic device,

generating first data related to the executed first application based on the obtained first resolution information, and

based on the first execution screen of the first application being designated to be displayed on the first external device, transmitting, to the first external device, the first data for displaying a first execution screen of the first application on the first external device; and

based on receiving a fourth input for the second application:

executing the second application exclusively on the electronic device,

generating second data related to the executed second application based on the obtained second resolution information, and

based on the second execution screen of the second application being designated to be displayed on the second external device, transmitting, to the second external device, the second data for displaying a second execution screen of the second application on the second external device.