

W. N. Whiteley.

Imp<sup>d</sup> Harvester-Rake

N<sup>o</sup> 85045

Patented Dec. 15, 1868

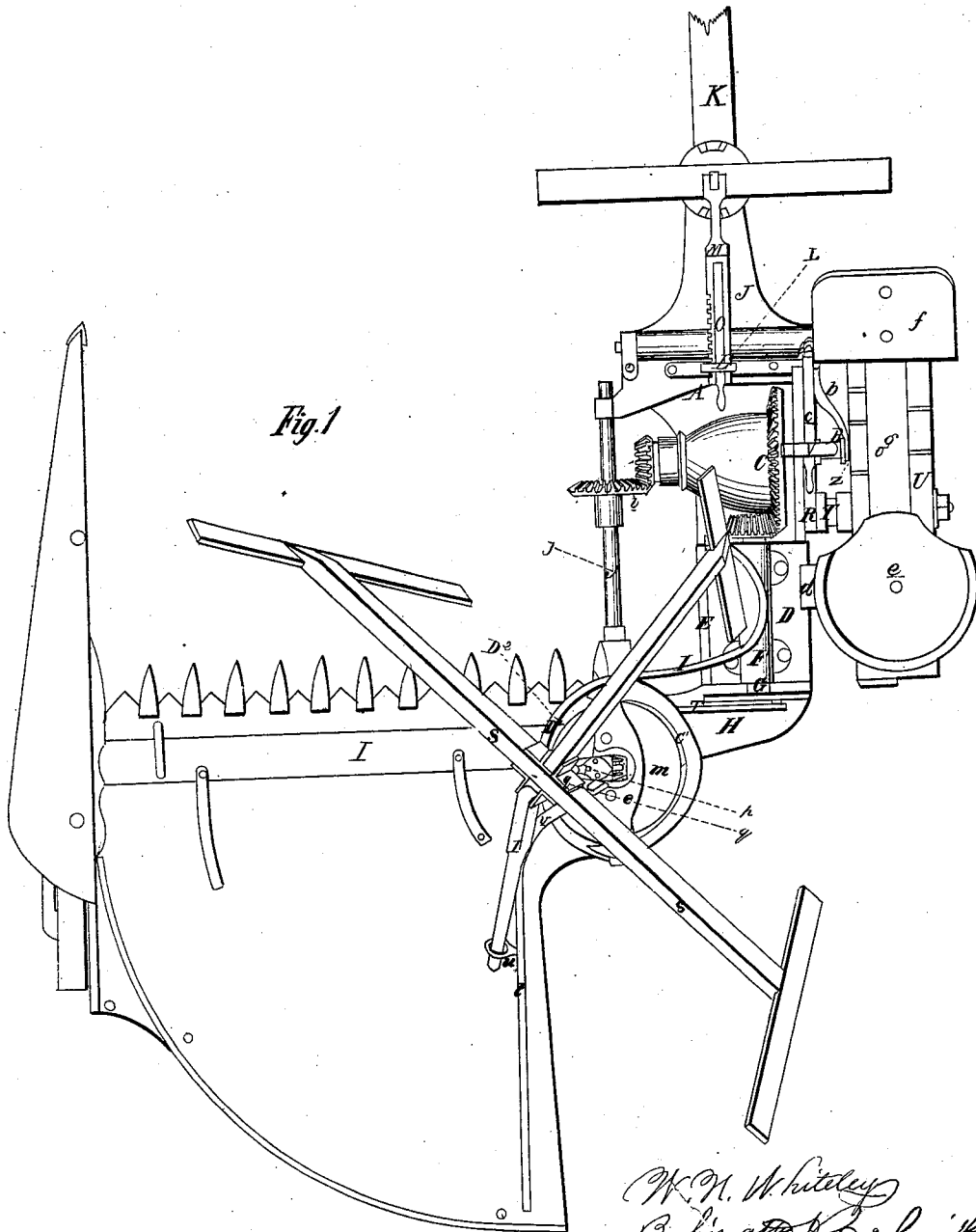

Fig. 1

R. S. Turner.  
Wm. F. Browne

W. N. Whiteley  
By his atty R. D. Smith  
451 Seventh St

W. N. Whiteley.

Imp<sup>d</sup> Harvester-Rake

N<sup>o</sup> 85045

Patented Dec. 15, 1868

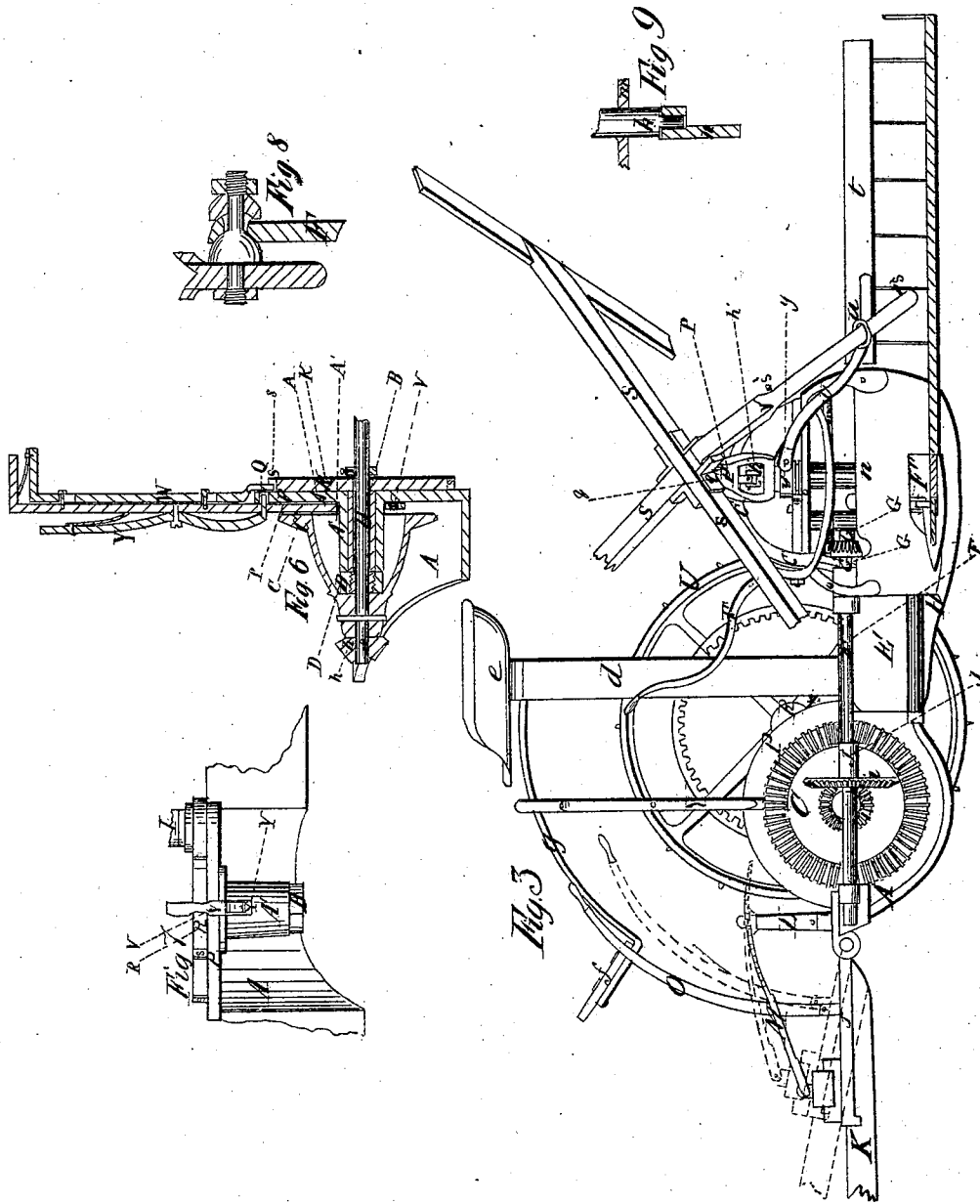

W. N. Whiteley  
By his atty R. D. Smith  
H. 51 St. Andrew St

W. N. Whiteley.

Imp<sup>d</sup> Harvester-Rake

N<sup>o</sup> 85045

Patented Dec. 15, 1868

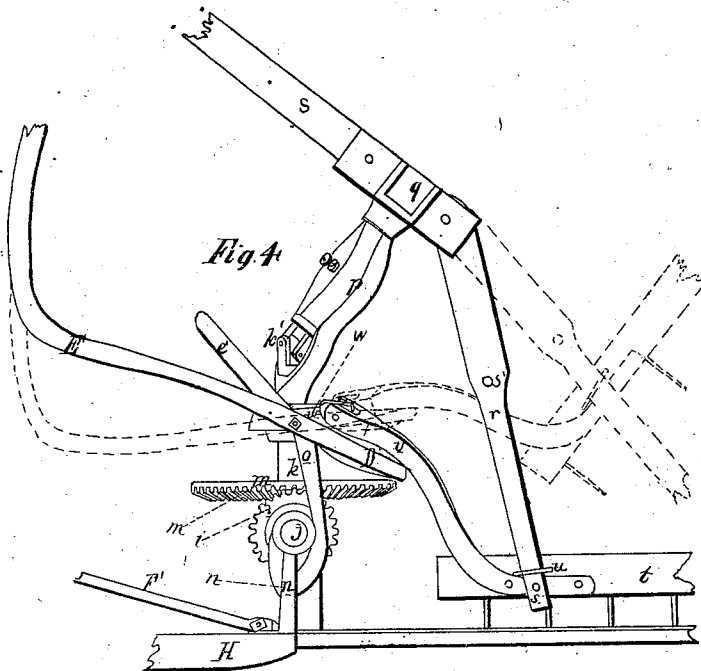
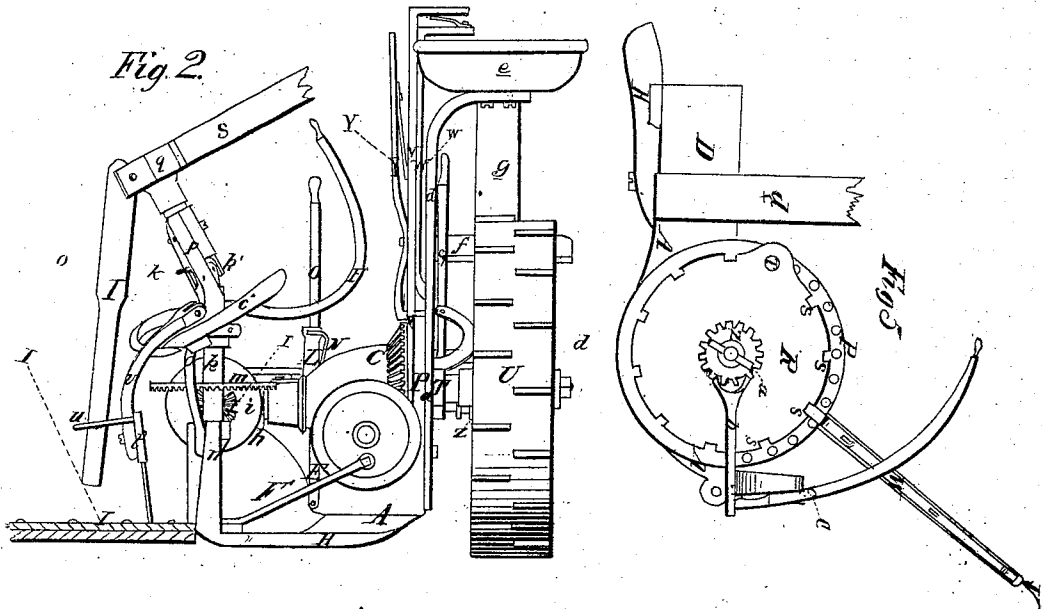

W. N. Whiteley  
By his atty R. D. Smith  
451 Second St.

# UNITED STATES PATENT OFFICE.

WILLIAM N. WHITELEY, OF SPRINGFIELD, OHIO.

## IMPROVEMENT IN HARVESTERS.

Specification forming part of Letters Patent No. **85,045**, dated December 15, 1868.

*To all whom it may concern:*

Be it known that I, W. N. WHITELEY, of Springfield, in the county of Clarke and State of Ohio, have invented a new and useful Improvement in Harvesters; and I do hereby declare the following to be a full, clear, and exact description of the same, reference being had to the accompanying drawings, in which—

Figure 1 is a plan of my invention. Fig. 2 is a rear elevation of the same. Fig. 3 is an inner side elevation of the same. Fig. 4 is an enlarged front elevation of operative mechanism of rake and reel. Fig. 5 is a side elevation of main frame, coupling-plate, &c., with main wheel removed. Fig. 6 is a vertical section through main pinion-shaft, &c. Fig. 7 is a plan view of pinion-shaft, bearing, &c. Fig. 8 is a sectional view of wrist-connection; Fig. 9, sectional elevation of flange at inner side of platform, showing socket for lower end of reel-shaft.

This is a single driving-wheel combined reaper and mower with a rigid cutting apparatus and a driving-wheel adjustable to regulate the height of the main frame.

A is the main frame, cast in a single piece, so as to form a shell extending beneath the principal gearing to protect it from contact with stubble or other obstructions which may be in the road over which the machine has to travel. Along the outer side the main frame forms a vertical plate, joined at its lower edge by the shell-plate, which extends beneath the gearing.

To the vertical portion of the frame A the bearing of the main pinion-shaft B is attached, and at the rear portion, behind the bevel driving-wheel C, which is secured to the main pinion-shaft, the frame assumes the form of a rectangular box, D, which is closed by a lid or door, E, and forms a receptacle for tools, &c., which it is convenient to carry with the machine. The tubular box F, in which the crank-shaft G has its bearings, is bolted to the upper side of the tool-box D, as shown in Fig. 1.

The rigid coupling-arm H is bolted to the lower side of the tool-box D, and is further secured from the lateral motion by two lugs, cast as a part of the main frame, and between which the said coupling-arm is placed when it is secured in its position. The coupling-arm H is curved, as shown, and its outer end is fashioned so as to form the inner shoe of the cutting ap-

paratus, and in a suitable recess in its upper surface the finger-bar I is firmly bolted. The draft-plate J is jointed to the front end of the main frame in the manner shown, and the tongue K is secured between parallel flanges on the lower side of the draft-plate in the usual manner.

A stud, L, stands upon the front end of the main frame, and a horizontal slot penetrates through the head of said stud. The notched stay-bar M is pivoted at the forward end of the draft-plate, and extends backward through the slot in the head of the stud L, with one side of which the notches in said bar engage. When the forward end of the tongue is raised the bar M slides farther through the notch in the head of the stud L, and when the tongue is depressed said bar is withdrawn from the slot; but at any desired point one of the notches may engage with the side of the stud L and hold the tongue in that position, and to retain it in the position desired the spring N is secured at one end to the side of the stud and at its other end presses against the plain side of the bar M, so as to retain it always in condition of engagement.

That the elevation of the front of the machine, and consequently of the points of the cutters, shall be always under control of the driver, the lever O is pivoted to the draft-plate, and passes thence upward through a slot in the bar M, and is curved backward, so as to bring its upper end within reach of the driver's hand. When the driver desires to raise or depress the front end of the machine he lays his hand upon the top of the lever O and presses it sidewise, so as to release the notches of the bar M from the side of the stud L, and then he can press said bar either forward or backward through its slot in the stud L, and permit it to become rigid again at any point desired. That part of the vertical portion of the main frame which is above the main pinion-shaft is in the form of a segment of a disk, P, the center of which is the axis of the main pinion-shaft B.

The hub A' is cast as a part of the main frame; or it may be secured thereto in any suitable way. It projects inward from the center of the disk P, and a corresponding hub or hollow axle, projecting from the center of the coupling-plate R, is fitted to the inner surface of said hub A', and is secured in that position

by screw-nut B'. The pinion-shaft B passes the hollow axle of the coupling-plate R and has its bearing thereon. This mode of construction insures great firmness and stability to the parts, and the long bearing afforded by the hollow hub A' insures easy and truthful operation.

At the inner end of the pinion-shaft B is secured firmly the bevel-wheel *h*, which transmits motion to the rake and reel. The bevel-wheel C, which transmits motion to the cutter's crank-shaft, is also secured firmly to the shaft B behind the bevel-wheel *h*. The wheel C is constructed with a deep cup-shaped hub, the outer end of which is fitted to the pinion-shaft, and it extends backward, surrounding the hub A', as shown in Fig. 6. This construction is employed so as to enable me to locate the gear-wheel C as near the driving-wheel as possible, as it is desirable to use a long pitman, if possible.

Through the disk P, near its upper edge, is a series of holes, Q Q, and on the pinion-shaft B, outside of the disk P, is another disk, R, with a series of notches, S, in its periphery, and to its outer face, at some point near its periphery, is secured the hub T, from which projects the axis of the main wheel U. The disk R then becomes a coupling arm or plate to connect the axle of the main wheel with the pinion-shaft, and to regulate the height of the main frame from the ground by permitting the pinion-shaft to be raised or lowered in respect to the axis of the main wheel. This adjustment of the height of the main frame is within certain limits always under control of the driver in the following manner. The lower end of the lever V is loosely hung upon the pinion-shaft B, and its upper end reaches upward within easy reach of the hand of the driver.

On the outer side of the lever V is the sliding latch-bolt W, the lower end of which engages with one of the notches S, so that when said lever is drawn backward the disk R, moving upon the axle T of the main wheel as a fixed fulcrum, rises up and elevates the pinion-shaft B and the main frame, which is suspended upon it, and when the top of the lever V is thrown forward the main frame and disk R sink toward the ground. The several notches S are provided, so that when the machine is designed to run high or low the lever V may be adjusted to be at a convenient distance from the driver's hand.

The amount of motion in raising or lowering the main frame at any one time while the machine is in operation will be comparatively slight; but if the lever V is fixed to the disk R its position is very different when the machine is set low upon the ground for moving than when set high for reaping.

Upon the inner side of the lever V is the spring-latch Y, the lower end of which engages in one of the holes Q Q near the edge of the plate P.

When the driver desires to change the height

of the cutting apparatus and main frame he places his hand upon the lever V, and withdrawing the latch Y from the hole Q, he may then, by pulling the lever toward him, cause the plate R to move upward on the axle T as a center, and per consequence the pinion-shaft B and the main frame will be raised up likewise. Motion is communicated to the main pinion-shaft and the working mechanism of the machine through the geared driver U and the pinion Z upon the outer end of the pinion-shaft B. The pinion Z is notched across its face, so as to engage with the clutch-pin *a*, which is inserted through the end of the pinion-shaft B, (see Fig. 5,) and said pinion is moved into or out of connection with said clutch-pin by means of the clutch-rod *b* and the lever *c*, which actuates it.

The standard *d* is bolted securely to the side of the main frame back of the sector-plates P and R. The top of this standard curves over sidewise above the driving-wheel V, and supports the driver's seat *e* at its upper end.

The driver's foot-board *f* is supported at the lower or forward end of an arm, *g*, the upper end of which is bolted to the upper end of standard *d*. This position of the driver's seat enables the driver's weight to counterbalance in some degree the weight of the cutting apparatus and platform, while the manner of mounting the seat and foot-board gives it great elasticity and renders the position comfortable to the occupant.

The bevel driving-pinion *h* on the inner end of the pinion-shaft B gears with pinion *i* on the countershaft *j*, which communicates motion to the rake and reel-shaft *k* by means of the bevel-wheels *l m*. The shaft *k* is stepped in a socket bored in the upper edge of the flange *n* (see Fig. 9) on the inner shoe, and its upper end is supported in bearings in the bridge *o*, the ends of which are securely bolted to the side of the flange *n*.

The shaft *k* is jointed at about its middle portion, the two parts being connected by a universal coupling or joint, *k'*. The lower portion is vertical, and the upper portion is inclined toward the platform. This arrangement is adopted in preference to a single straight and inclined shaft, in order to secure the advantageous arrangement of an inclined shaft and sufficient height above the platform without carrying the head of the reel too far over the platform. The upper or inclined portion of the shaft *k* is secured in bearings in the inclined post *p*, which stands upon and is secured to the top of the bridge *o*.

The head *q*, which carries the reel-arms and the arm which drives the rake, is provided with parallel lugs or flanges projecting in four directions, and between those lugs the reel-arms *s s* are rigidly secured, projecting at right angles from the shaft and perpendicular to its axis.

On the fourth side the arm *r*, which drives the rake, is pivoted. The lower end of this arm

*r* passes through a ring, *u*, or some similar device attached to the front side of the rake-head *t*. The rake-head *t* is connected to the shaft *h* by the arm *v*, which is pivoted at its upper end to the collar *w*, which surrounds said shaft above the bridge *o*, so that the rake may rise and fall, moving upon its joint-connection with said collar independent of the reel, and it is caused to move forward or backward by the action of the arm *r*. When the rake rises up said arm simply slides farther through the ring and maintains the speed of rake practically unchanged.

The grain in the field is frequently so thin that during one revolution of the rake not sufficient grain will be cut to form a gavel, and it is then desirable that the driver should be able to control the action of the rake, so as to cause it to pass over the grain upon the platform whenever he desires. This purpose I accomplish by forming the guideway in the parts *C'* and *D'*. The part *C'* is fixed and stands at an inclination of about forty-five degrees to the level of the platform. When the arm *v* travels over this portion of the guideway it is lifted up, so that the rake sweeps above the main frame, gearing, &c, and descends again into the grain upon the platform.

The part *D'* is made movable, and is pivoted to the ends of the guide *C'*, or to some convenient portion of its supporting-frame. The forward end of the part *D'* may be extended so as to form the lever *E'*, by which the part *D'* may be operated to act as a guideway for the rake. The lever *E'* extends inward and forward, so that its end is in a position convenient to the hand of the driver, and when he wishes to prevent the rake from removing the grain he depresses this end of the lever *E'*, elevating the outer portion of the guide *D'*, as shown in Fig. 4, and thereby cause the arm *v* and the rake to be raised high enough to avoid sweeping the grain from the platform.

The pitman *F'* is forked at the end which is jointed to the cutter-bar, and said joint is formed with conical or conoidal points projecting from one part into corresponding sockets in the other, the joint being kept tight by a screw-bolt, which passes through both parts of the pitman and draws them together, as may be necessary. The wrist-connection is formed with a cup-shaped socket in the pitman-head and a hemispherical head on the wrist-pin fitting said socket. The central portion of the socket is bored through, so that a central pin from the wrist may project entirely through the pitman-head for the purpose of securing the two parts together, as shown in Fig. 8. The object of this method of construction is to permit a limited variation or lateral motion in the pitman to accommodate itself to the slight variations of the cutting apparatus, &c.; and also to enable the attendant to keep the wrist-joint in snug and proper working order; and to fully accomplish this object I make the outer side of the pitman-head of shape correspond-

ing to the inner socket, and fit a cup-shaped washer over it, interposed between the pitman and the screw-nut which holds the joint together.

The stops *s' s'* serve to limit the movement of the rake-head in a vertical direction by arresting the motion of the ring *u* upon the pendent driving-arm *r*.

Having described my invention, what I claim as new is—

1. The main frame *A*, cast in a single piece with the disk *P*, and tool-box *D*, all as shown and described.

2. Making the bearing of the pinion-shaft *B* through the center of the hub of the sector-plate *R*, and the bearing of the latter through the center of the hub *A'*, and securing these parts in place in the manner shown.

3. The driver's seat *e* and foot-board *f*, mounted at the upper end of the standard *d*, said standard being rigidly secured to the main frame, and its upper end curved outward over the main wheel, as and for the purpose set forth.

4. The bevel-wheel *C*, provided with the hollow hub, as shown, in connection with the bearing-hub *A'*, projecting from the main frame *A*, and the hub of the sector-plate *R*, substantially as shown and described, and for the purpose set forth.

5. The lever *V*, provided with latches *W* and *Y*, in connection with the disks *P* and sector-plate, substantially as described.

6. The combination of the hemispherical or conoidal wrist-pin with the corresponding socketed pitman-head and the socketed washer, as shown and described.

7. The reel-shaft *k*, made in two parts, as shown, and mounted in bearings in the post *p*, as shown, the two parts connected by a universal coupling, *k'*, the lower part perpendicular to the surface of the platform, and the upper part inclined thereto, and always held in the same relative position, as and for the purpose shown and described.

8. The combination of the rake and reel, when constructed to operate substantially in the manner shown—*i. e.*, the reel moving around the axis of the inclined shaft in fixed planes, a collar which moves around the axis of the vertical shaft in a plane at right angles thereto, and the rake jointed to said collar in such a manner that it may rise and fall in a plane parallel with the axis of said vertical shaft, and all actuated by the same mechanism.

9. Making the guideway in two parts, *C' D'*, *C'* being fixed and *D'* jointed thereto, substantially as shown, so that the position of the part *D'* may be changed at the will of the attendant as regards the fixed part *C'*, and the path of the rake be thereby raised from the platform, as and for the purpose set forth.

10. Elongating one end of the movable part *D'* to form the lever *E'*, which extends to a position convenient to the hand of the driver, and

acts directly upon said movable part, in the manner and to the effect shown and described.

11. The independent rake-head *t*, provided with the screw *v*, jointed to the collar *w*, or its equivalent, hung around the reel-shaft, and operated by a pendent arm jointed to the reel-head, substantially as and for the purpose set forth.

12. The combination of the driving-arm *r*

and rake-head *t*, connected by the stationary ring *u*, and operating as shown and described.

13. The stops *s' s'* on the driving-arm *r* to limit the movement of said arm and the rake-head upon each other.

WILLIAM N. WHITELEY.

Witnesses:

THOMAS HARDING,  
CLAY WHITELEY.