



(86) Date de dépôt PCT/PCT Filing Date: 2010/04/21
 (87) Date publication PCT/PCT Publication Date: 2010/10/28
 (85) Entrée phase nationale/National Entry: 2011/10/19
 (86) N° demande PCT/PCT Application No.: US 2010/031958
 (87) N° publication PCT/PCT Publication No.: 2010/124032
 (30) Priorité/Priority: 2009/04/23 (US61/172,116)

(51) Cl.Int./Int.Cl. *A61B 17/70* (2006.01),
A61B 17/84 (2006.01), *A61B 17/86* (2006.01)
 (71) Demandeur/Applicant:
SPINAL ELEMENTS, INC., US
 (72) Inventeurs/Inventors:
BLAIN, JASON, US;
MARTIN, GREG, US;
HOWARD, STEVEN, US
 (74) Agent: SMART & BIGGAR

(54) Titre : **CONNECTEURS TRANSVERSAUX**
 (54) Title: **TRANSVERSE CONNECTORS**

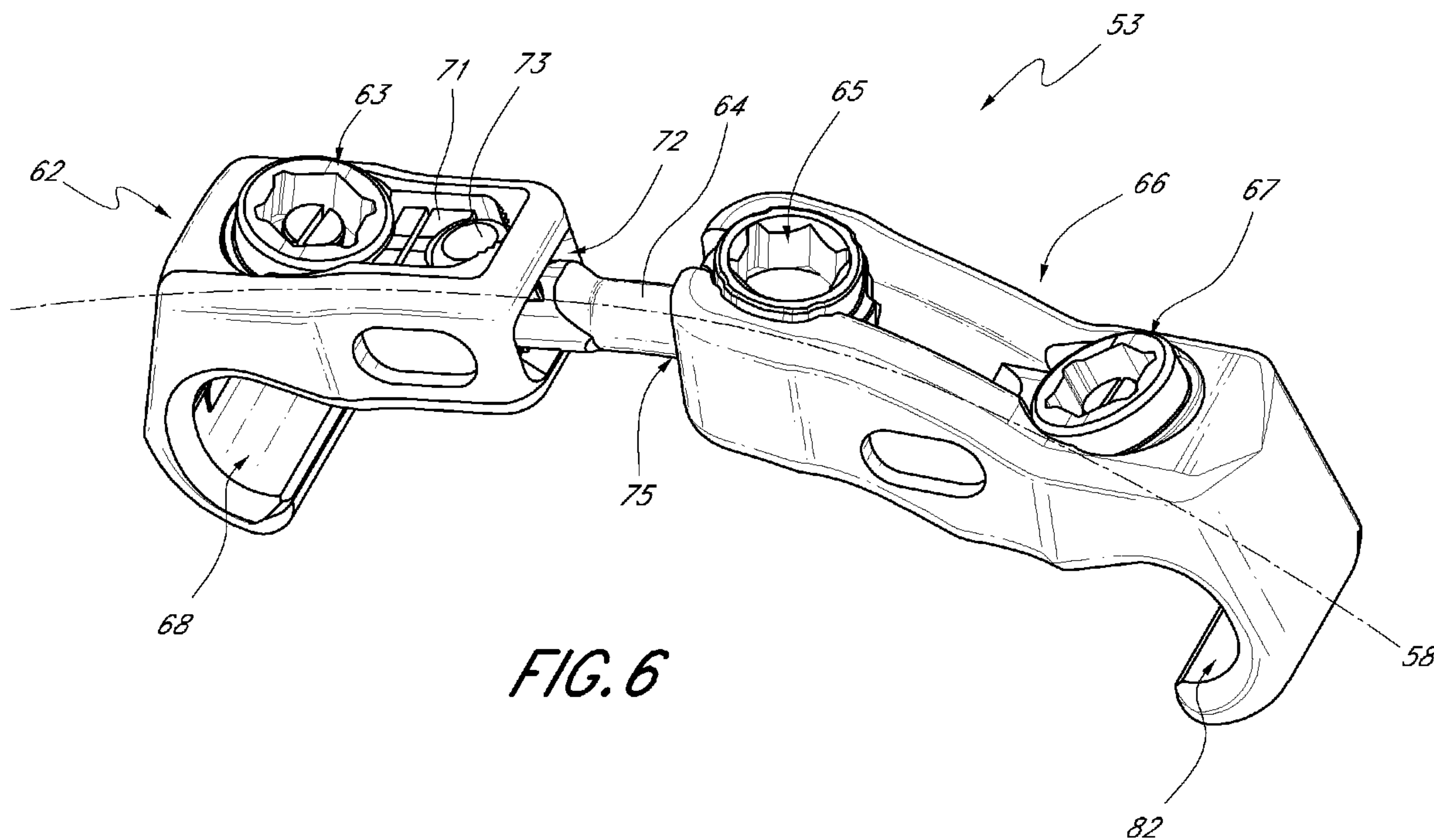

FIG. 6

(57) **Abrégé/Abstract:**

Devices and methods are disclosed for treating the vertebral column. One embodiment provides a transverse connector for vertebral fixation systems comprising a first connector body comprising a first engaging member for engaging a first elongate member and a first locking member, a second connector body comprising a second engaging member for engaging a second elongate member, and a transverse rod coupled to the first connector body and the second connector body, thereby forming an articulation between a first end of the transverse rod and the first connector body, wherein the first locking member is configured to secure both the articulation and the first elongate member to the first connector body.



(12) INTERNATIONAL APPLICATION PUBLISHED UNDER THE PATENT COOPERATION TREATY (PCT)

(19) World Intellectual Property Organization
International Bureau(43) International Publication Date
28 October 2010 (28.10.2010)(10) International Publication Number
WO 2010/124032 A3

(51) International Patent Classification:

A61B 17/70 (2006.01) A61B 17/86 (2006.01)
A61B 17/84 (2006.01)

(21) International Application Number:

PCT/US2010/031958

(22) International Filing Date:

21 April 2010 (21.04.2010)

(25) Filing Language:

English

(26) Publication Language:

English

(30) Priority Data:

61/172,116 23 April 2009 (23.04.2009) US

(71) Applicant (for all designated States except US): **SPINAL ELEMENTS, INC.** [US/US]; 2744 Loker Avenue West, Suite 100, Carlsbad, CA 92010 (US).

(72) Inventors; and

(75) Inventors/Applicants (for US only): **BLAIN, Jason** [US/US]; 1266 Orchard Glen Circle, Encinitas, CA 92024 (US). **MARTIN, Greg** [US/US]; 270 Neptune, Encinitas, CA 92024 (US). **HOWARD, Steven** [US/US]; 5585 Via Bello, San Diego, CA 92111 (US).(74) Agent: **DELANEY, Karoline, A.**; Knobbe, Martens, Olson & Bear, LLP, 2040 Main Street, 14th Floor, Irvine, CA 92614 (US).

(81) Designated States (unless otherwise indicated, for every kind of national protection available): AE, AG, AL, AM, AO, AT, AU, AZ, BA, BB, BG, BH, BR, BW, BY, BZ, CA, CH, CL, CN, CO, CR, CU, CZ, DE, DK, DM, DO, DZ, EC, EE, EG, ES, FI, GB, GD, GE, GH, GM, GT, HN, HR, HU, ID, IL, IN, IS, JP, KE, KG, KM, KN, KP, KR, KZ, LA, LC, LK, LR, LS, LT, LU, LY, MA, MD, ME, MG, MK, MN, MW, MX, MY, MZ, NA, NG, NI, NO, NZ, OM, PE, PG, PH, PL, PT, RO, RS, RU, SC, SD, SE, SG, SK, SL, SM, ST, SV, SY, TH, TJ, TM, TN, TR, TT, TZ, UA, UG, US, UZ, VC, VN, ZA, ZM, ZW.

(84) Designated States (unless otherwise indicated, for every kind of regional protection available): ARIPO (BW, GH, GM, KE, LR, LS, MW, MZ, NA, SD, SL, SZ, TZ, UG, ZM, ZW), Eurasian (AM, AZ, BY, KG, KZ, MD, RU, TJ, TM), European (AT, BE, BG, CH, CY, CZ, DE, DK, EE, ES, FI, FR, GB, GR, HR, HU, IE, IS, IT, LT, LU, LV, MC, MK, MT, NL, NO, PL, PT, RO, SE, SI, SK, SM, TR), OAPI (BF, BJ, CF, CG, CI, CM, GA, GN, GQ, GW, ML, MR, NE, SN, TD, TG).

Published:

— with international search report (Art. 21(3))

(88) Date of publication of the international search report:

21 April 2011

(54) Title: TRANSVERSE CONNECTORS

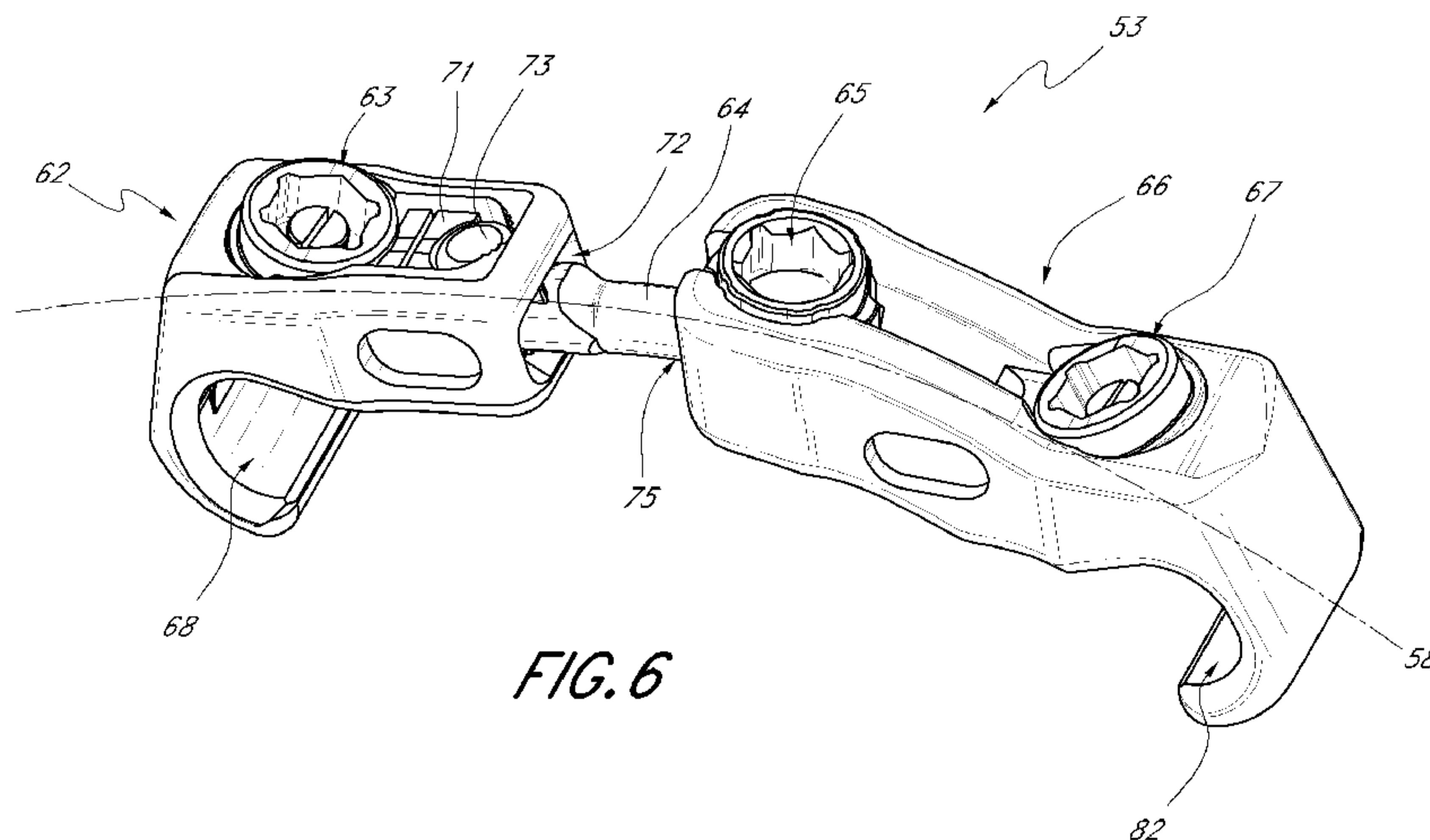

FIG. 6

(57) Abstract: Devices and methods are disclosed for treating the vertebral column. One embodiment provides a transverse connector for vertebral fixation systems comprising a first connector body comprising a first engaging member for engaging a first elongate member and a first locking member, a second connector body comprising a second engaging member for engaging a second elongate member, and a transverse rod coupled to the first connector body and the second connector body, thereby forming an articulation between a first end of the transverse rod and the first connector body, wherein the first locking member is configured to secure both the articulation and the first elongate member to the first connector body.

TRANSVERSE CONNECTORS

BACKGROUND OF THE INVENTION

Field of the Invention

[0001] The present invention relates generally to transverse connectors used in spinal fixation systems. The invention comprises assemblies that are coupled to spinal rods, plates, or other elongate members to provide stability to a construct. The invention may be configured so that multiple transverse connectors may be used along the vertebral column.

Description of the Related Art

[0002] Advancing age, as well as injury, can lead to degenerative changes in the bones, discs, joints and ligaments of the spine, producing pain and instability. Under certain circumstances, alleviation of the problems can be provided by performing spinal fusion. Spinal fusion is a surgical technique where two or more vertebrae of the spinal column are fused together to eliminate the motion between the fused vertebrae. Spinal fusion is used to treat conditions where the spine exhibits instability. Spine instability may result from causes such as fracture, scoliosis and spondylolisthesis, where one or more vertebrae move in a forward direction relative to the other vertebrae. Spinal fusion with discectomy is also performed for herniations of the discs. This surgery involves removal of the affected disc and fusion of the adjacent vertebrae. Traditionally, bone grafts have been used to fuse the vertebrae, but various types of vertebral implants have also been used.

[0003] The use of fixation systems for achieving spinal fusion is well established. One of the more common fixation systems is the pedicle screw fixation system. In this fixation system, pedicle screws are inserted into two or more vertebrae and interconnected with a rod or other elongate member. The screws are rigidly connected to the elongate member so that the fixation system greatly reduces motion between the adjoining vertebrae. Multiple fixation systems may be utilized to achieve greater strength and stability. Other types of fixation systems use different vertebrae attachment devices, including but not limited to, transverse process hooks, sublaminar hooks, pedicle hooks, fixation plates and other similar devices.

[0004] It is well known in the art that coupling multiple fixation systems with a transverse connector also increases strength and stability of the assembly. A transverse connector is used to span the distance between two elongate members. Ideally, the fixation system is implanted in the body so that the two elongate members are substantially parallel to each other in a single plane. This permits the use of a simple transverse connector that need only be adjustable in length, along its longitudinal axis. However, due to variations in body geometries and implanting inconsistencies, the elongate members are rarely parallel in practice. The elongate members may be co-planar but not parallel, or may not be co-planar, or both not co-planar nor parallel. In the past, this problem was addressed by forcefully bending the elongate members or the transverse connector to accommodate for the misalignment of the elongate members. This solution is not optimal because it introduces misalignments that possibly compromise the strength and stability of the assembly. Additionally, it could weaken the mechanical properties of the elongate member or the transverse connector.

[0005] Prior inventions addressed this problem through the use of a transverse connector with greater adjustability. U.S. Pat. No. 5,980,523 discloses a transverse connector with separable pieces that are assembled together with separate screw fasteners to accommodate for non-parallel elongate members. The disadvantage with this invention is the number of separable pieces, which are difficult to assemble in the clinical environment, especially considering the miniature sizes of some of the pieces. Surgeons may also risk losing pieces within the patient's body cavity during implantation.

[0006] Further advancements solved this problem with the invention of a one-piece transverse connector, but there still remains some shortcomings. For example, U.S. Pat. No. 6,736,817 discloses a one-piece transverse connector that is adjustable for convergent or divergent elongate members, non-coplanar elongate members, and variations in distances between elongate members. The adjustment for convergence or divergence is accomplished through a joint placed between two coupling hooks that attach to elongate members. The joint comprises of two mating surfaces, each with teeth that allows the two ends of the transverse connector to hinge with respect to each other at various angles. The hinge joint is locked with a screw fastener. However, the disadvantage of this design is the

complexity of the additional screw. The added screw introduces an additional component for possible failure or user error. Also, the additional weight and bulk of the hinge joint is another drawback of the design. The vertebral fixation assembly may be placed in the human body for extended periods of time. Any tiny additional weight or bulk of the fixation assembly can translate into greater discomfort for the patient. Thus, it is advantageous for the vertebral fixation assembly to be as compact as possible to minimize its intrusion in the body.

[0007] As a consequence of the foregoing, there remains a need for improved adjustable transverse connectors with simple, compact adjustments.

SUMMARY OF THE INVENTION

[0008] The present invention relates generally to transverse connectors used in spinal fixation systems.

[0009] One embodiment provides a transverse connector for vertebral fixation systems comprising a first connector body comprising a first engaging member for engaging a first elongate member and a first locking member, a second connector body comprising a second engaging member for engaging a second elongate member, and a transverse rod coupled to the first connector body and the second connector body, thereby forming an articulation between a first end of the transverse rod and the first connector body, wherein the first locking member is configured to secure both the articulation and the first elongate member to the first connector body.

[0010] The above embodiments and methods of use are explained in more detail below.

BRIEF DESCRIPTION OF THE DRAWINGS

[0011] The structure and method of using the invention will be better understood with the following detailed description of embodiments of the invention, along with the accompanying illustrations, in which:

[0012] **Figure 1** is a lateral elevational view of a portion of the vertebral column.

[0013] **Figures 2A and 2B** are superior and lateral elevational views of a thoracic vertebra.

[0014] **Figure 3** illustrates a superior elevational view of a cervical vertebra.

[0015] **Figure 4** represents a superior elevational view of a lumbar vertebra.

[0016] **Figure 5** is a top plan view of one embodiment of a vertebral fixation assembly.

[0017] **Figure 6** is a top perspective view of one embodiment of an adjustable transverse connector.

[0018] **Figure 7** is an exploded view of one embodiment of a rod connector with an articulation and a first locking member.

[0019] **Figure 8** is a cross-sectional view of one embodiment of an adjustable transverse connector showing a rod connector with a second locking member and a transverse rod with a third locking member.

[0020] **Figure 9** is a cross-sectional exploded view of one embodiment of a slideable and rotational transverse rod with a third locking member.

DETAILED DESCRIPTION OF THE PREFERRED EMBODIMENT

[0021] Advancing age, as well as injury, can lead to degeneration in the bones, discs, joints, and ligaments of the spine producing pain from nerve root compression. Under certain circumstances, alleviation of pain can be provided by performing a spinal fusion. Spinal fusion is a procedure that involves joining two or more adjacent vertebrae so that they no longer are able to move relative to each other.

A. Anatomy of the Spine

[0022] As shown in **FIG. 1**, the vertebral column 2 comprises a series of alternating vertebrae 4 and fibrous discs 6 that provide axial support and movement to the upper portions of the body. The vertebral column 2 typically comprises thirty-three vertebrae 4, with seven cervical (C1-C7), twelve thoracic (T1-T12), five lumbar (L1-L5), five fused sacral (S1-S5) and four fused coccygeal vertebrae. **FIGS. 2A** and **2B** depict a typical thoracic vertebra. Each vertebra includes an anterior body 8 with a posterior arch 10. The posterior arch 10 comprises two pedicles 12 and two laminae 14 that join posteriorly to form a spinous process 16. Projecting from each side of the posterior arch 10 is a transverse 18, superior 20 and inferior articular process 22. The facets 24, 26 of the superior 20 and inferior articular processes 22 form facet joints 28 with the articular processes of the adjacent vertebrae.

[0023] The typical cervical vertebrae 30, shown in **FIG. 3**, differ from the other vertebrae with relatively larger spinal canals 32, oval shaped vertebral bodies 34, bifid spinous processes 36 and foramina 38 in their transverse processes 40. These foramina transversaria 38 contain the vertebral artery and vein. The first and second cervical vertebrae also further differentiated from the other vertebrae. The first cervical vertebra lacks a vertebral body and instead contains an anterior tubercle. Its superior articular facets articulate with the occipital condyles of the skull and are oriented in a roughly parasagittal plane. The cranium is able to slide forward and backwards on this vertebra. The second cervical vertebra contains an odontoid process, or dens, which projects superiorly from its body. It articulates with the anterior tubercle of the atlas, forming a pivot joint. Side to side movements of the head occur at this joint. The seventh cervical vertebra is sometimes considered atypical since it lacks a bifid spinous process.

[0024] Referring to **FIG. 4**, the typical lumbar vertebrae 42 is distinguishable from the other vertebrae by the absence of foramina transversaria and the absence of facets on the surface of the vertebral body 44. The lumbar vertebral bodies 44 are larger than the thoracic vertebral bodies and have thicker pedicles 46 and laminae 48 projecting posteriorly. The vertebral foramen 50 is triangular in shape and larger than the foramina in the thoracic spine but smaller than the foramina in the cervical spine. The superior 52 and inferior articular processes (not shown) project superiorly and inferiorly from the pedicles, respectively.

B. Transverse Connector

[0025] **FIG. 5** shows one embodiment of a vertebral fixation system 55, comprising a transverse connector 53 connecting a first elongate member 54 and a second elongate member 56. In some embodiments, the elongate members 54 and 56 are coupled to the vertebral column using attachment devices, such as pedicle screws. For example, a first pedicle screw 60 may be attached to a pedicle of a first vertebra and a second pedicle screw 61 may be attached to a pedicle of a second vertebra. Although depicted as pedicle screws in **FIG 5**, the means for coupling the elongate members 54 and 56 to the vertebral column can be any attachment device that can couple an elongate member to a vertebra. For example, in other embodiments, the attachment devices may be hooks, clamps or other fastening device.

The elongate member may be any rigid member capable of coupling to and stabilizing the vertebral column, such as a spinal rod. In some embodiments, the elongate members 54 and 56 may be rectangular bars, polygonal bars, I-beams, or any other device suitable for connecting the pedicle screws.

[0026] The two elongate members are coupled to each other using a transverse connector 53. In some embodiments, the transverse connector has generally a curved shape to allow for the posterior arch of the vertebral column. The transverse connector 53 can be comprised of any material that is suitable for orthopedic applications, such as titanium, stainless steel, metal alloys, plastics, or other material compatible for use in the body. **FIG. 6** shows one embodiment of the transverse connector 53, which comprises a first connector body 62 coupled to a second connector body 66 via a transverse rod 64. The transverse rod 64 comprises an end with a pivot joint 73 and a projection end 75. The end with a pivot joint 73 is configured to couple to the first connector body 62, thereby forming an articulation between the first connector body 62 and the transverse rod 64. The projection end 75 of the transverse rod 64 is configured to couple to the second connector body 66. The transverse connector 53 spans the distance between two elongate members and may be used to add stability, such as torsional stability, to the vertebral fixation system 55. In some embodiments, the transverse connector 53 is adjustable in length and can adapt for multi axial rotational differences in the orientations of the elongate members.

[0027] The first connector body 62 comprises a first locking member 63 and a first engaging member 68. In some embodiments, the first connector body 62 further comprises a pushing member 71. As shown in **FIG. 7**, in some embodiments, the first connector body 62 comprises a first engaging member 68 toward one end for engaging the first elongate member 54 to the first connector body 62. The first connector body 62 also comprises a through bore 57 from a first surface of the connector body to a second surface of the connector body, wherein the second surface of the connector body is adjacent to the first engaging member 68. The through bore 57 houses the first locking member, which comprises a first locking nut 70 for securing an elongate member within the first engaging member 68.

[0028] In some embodiments, the first engaging member 68 may be a hooked end configured to accept an elongate member such as a spinal rod. In other embodiments, the first engaging member 68 may have a different design that is compatible with other types of elongate members, such as polygonal bars or I-beams. In some embodiments, the first locking nut 70 can secure the elongate member by pushing the elongate member against the first engaging member 68.

[0029] In some embodiments, the first locking member 63 may further comprise a first contacting saddle 69 configured to make contact with and secure an elongate member in the first engaging member 68. In some embodiments, the surface of the first contacting saddle 69 that contacts the first locking nut 70 has a helical surface, which corresponds with the helical surface on the bottom surface of the first locking nut 70. In other embodiments, the complimentary surfaces are contours other than helical. In some embodiments, turning the first locking nut 70 may cause the contacting saddle 69 to push down on the elongate member, thereby securing the elongate member to the first connector body 62 in the engaging member 68.

[0030] In some embodiments, the first locking member 63 is configured to secure both the articulation (i.e., lock the pivot joint 73 of the transverse rod 64) and the first elongate member 54 to the first connector body 62. The first connector body 62 may also comprise a passage 72 that has one opening toward the medial end and the other opening in the through bore 57. The passage 72 houses the pushing member 71 and the pivot joint end of the transverse rod 64. In some embodiments, the pivot joint 73 comprises a cylindrical shape with a longitudinal axis 74 that is generally perpendicular to the longitudinal axis 58 of the transverse rod 64. The projection end 75 extends out from the medial opening of the passage 72 in the first connector body 62. In some embodiments, the medial opening of the passage 72 is configured to permit the transverse rod 64 to pivot at the pivot joint 73 about the longitudinal axis 74 of the pivot joint when the first locking member 63 is in an unlocked position, creating an angle α measured between the longitudinal axis 58 of the transverse rod 64 and the longitudinal axis 59 of the first connector body 62, as illustrated in FIG. 5. For example, the medial opening may be larger than the diameter of the transverse rod 64, particularly in the lateral directions, to allow the transverse rod 64 to swing from one side to

the other along the defined plane. This pivoting movement allows the transverse connector 53 to adjust for convergence or divergence of the implanted elongate members 54 and 56. In some embodiments, the pivot joint 73 may comprise other configurations that permit the transverse rod 64 to pivot along a different plane.

[0031] In some embodiments, the pushing member 71 can be coupled to both the pivot joint 73 of the transverse rod 64 within the passage 72 and the first locking nut 70 through the opening in the through bore 57. In some embodiments, the surface of the pushing member 71 that contacts the first locking nut 70 can have a helical surface complimentary to the second helical surface on the first locking nut 70. The helical surfaces can be configured so that as the locking nut 70 is turned to the lock position, the pushing member 71 pushes the pivot joint 73 up and medially to lock the pivot joint 73 against the interior wall of the passage 72 in the first connector body 62. In other embodiments, the complimentary surfaces can be contours other than helical.

[0032] For example, in some embodiments, the first locking nut 70 can have a cam surface disposed on the outer cylindrical surface which couples with the pushing member 71. The cam surface can have a radial gradient wherein the radius of the cam surface can increase from one side of the cam surface to the other side of the cam surface. When the first locking nut 70 is rotated, the increasing radius of the cam surface can push the pushing member 71 in the medial direction, thereby translating rotational motion of the first locking nut 70 into linear movement of the pushing member 71.

[0033] The pushing member 71 can have a generally trapezoidal wedge configuration with coupling surfaces for the first locking nut 70 and the pivot joint 73. In some embodiments, the pushing member 71 can have a slot disposed along the lateral direction that extends from the top of the pushing member 71 down to a partial height of the pushing member 71. When the first locking nut 70 biases the pushing member 71 against the pivot joint 73, the slotted pushing member 71 can partially deform to provide a spring force to the pivot joint 73. In other embodiments, the slot in the pushing member 71 can be omitted.

[0034] In some embodiments, the pivot joint 73 can have a roughened surface on at least a portion of its surface that contacts a complimentary surface on the first connector

body 62 when the first locking nut 70 is tightened or in the locked position. Some examples of the roughened surface include, but are not limited to teeth, ridges, or abrasive surfaces. When the first locking nut 70 is tightened or locked, the transverse rod 64 is fixed and can no longer pivot along the defined plane.

[0035] In some embodiments, the pivot joint 73 can comprise elongate teeth or grooves that are disposed along the longitudinal axis 74 on at least a portion of the cylindrical surfaces that contacts the first connector body 62. The first connector body 62 can comprise a complimentary surface with elongate teeth or grooves that can couple with the elongate teeth or grooves on the pivot joint 73 to restrict the pivotal movement of the transverse rod 64. In other embodiments, the elongate teeth or grooves may be omitted from the pivot joint 73.

[0036] As shown in **FIG. 8**, the second connector body 66 comprises a second locking member 67, a third locking member 65 and a second engaging member 82. The second connector body 66 comprises a receiving bore 80 that has an opening at the medial end of the second connector body 66. The receiving bore 80 is configured to receive the projection end 75 of the transverse rod 64, which allows the second connector body 66 to slide along generally the longitudinal axis 58 of the transverse rod 64 to account for variations in implanted distances of elongate members 54 and 56. In some embodiments, the second connector body 66 can also rotate generally about the longitudinal axis 58 to account for non-parallel and/or non co-planar elongate members 54 and 56.

[0037] In some embodiments, the transverse rod 64 is allowed to slide in and out of the receiving bore 80 along generally the longitudinal axis 58 of the transverse rod 64 so as to lengthen and shorten the overall length of the transverse connector 53. In some embodiments, the transverse rod 64 may also rotate within the receiving bore 80 generally about the longitudinal axis 58. In some embodiments, the transverse rod 64 further comprises a retaining pin 77 toward the end of the projection end 75 as shown in **FIG. 8**. The retaining pin 77 serves to stop the transverse rod 64 from sliding out of the receiving bore 80 completely and limits the rotation of the transverse rod 64 within the receiving bore 80 about axis 58. As an inseparable piece, the transverse connector 53 is easier to handle and to implant without having to account for several small pieces.

[0038] With reference to **FIGS. 8** and **9**, in some embodiments, the retaining pin 77 may be engaged in a groove 81 located on the underside of the second connector body 66. In some embodiments, the groove 81 is an elongated cutout that is large enough to allow the movement of the retaining pin 77 when the transverse rod 64 slides and rotates inside of the receiving bore 80. In some embodiments, the groove 81 may also be a recess within a portion of the receiving bore that is large enough to accommodate retaining pin 77 movements. The angle of rotation allowed by the groove 81 is labeled as β in **FIG. 9**. In some embodiments, about a 90 degree freedom of rotation of the transverse rod 64 is sufficient to account for angular variations of non-parallel connector rods in the usual clinical environment. However, groove sizes that allow for less or more than 90 degrees of rotation of the transverse rod 64 may be appropriate for some situations.

[0039] The second connector body 66 also comprises a first through bore from a first surface of the connector body to a second surface of the connector body, wherein the opening of the second through bore on the second surface of the connector body is adjacent to the second engaging member 82. The first through bore of the second connector body 66 houses the second locking member 67, which comprises a second locking nut 79 for securing a second elongate member 56 within the second engaging member 82.

[0040] In some embodiments, the second engaging member 82 may be a hooked end configured to accept an elongate member such as a spinal rod. In other embodiments, the second engaging member 82 may have a different design that is compatible with other types of elongate members, such as polygonal bars or I-beams. In some embodiments, the second locking nut 79 can secure the second elongate member 56 by pushing the elongate member against the second engaging member 82.

[0041] In some embodiments, the second locking member 67 may further comprise a second contacting saddle 78 configured to make contact with and secure the second elongate member 56 in the second engaging member 82. The surface of the second contacting saddle 78 that contacts the second locking nut 79 has a helical surface, which is complimentary to the helical surface on the bottom surface of the second locking nut 79. In other embodiments, the complimentary surfaces are contours other than helical. In some embodiments, turning the second locking nut 79 to a locked position may cause the

contacting saddle 78 to push down on the second elongate member 56, thereby securing the second elongate member 56 to the second connector body 66 in the second engaging member 82.

[0042] With reference to **FIGS. 6, 8 and 9**, the second connector body 66 further comprises a second through bore 85 from the first surface of the connector body to the receiving bore 80 at the medial end of the second connector body 66. The second through bore 85 of the second connector body 66 houses the third locking member 65. The third locking member 65 comprises a third locking nut 83, which is configured to secure the transverse rod 64 to the second connector body 66. Once the length and axial rotation of the transverse rod 64 are positioned within the receiving bore 80, the transverse rod 64 can be locked by tightening the third locking nut 83.

[0043] In some embodiments, the third locking member 65 may further comprise a transverse rod contacting saddle 84. In some embodiments, the third locking nut 83 is a cylindrical body with a helical surface on its outer cylindrical wall which, when tightened or locked, contacts a complimentary helical surface on the second connector body 66 causing the third locking nut 83 to apply pressure against the transverse rod contacting saddle 84, which in turn applies pressure to the transverse rod 64, locking it in place. In other embodiments, the complimentary surfaces are contours other than helical. In some embodiments, the transverse rod contacting saddle 84 is a cylindrical body with a concave surface on one end for accepting and locking the transverse rod 64 in a fixed position and a flat surface on the other end for mating with the bottom flat surface of the third locking nut 83. In other embodiments, the transverse rod contacting saddle 84 may be omitted and the third locking nut 83 can be in contact with the transverse rod 64. The third locking nut 83 can apply pressure directly to the transverse rod 64. In some embodiments, the bottom surface of the third locking nut 83 can be spherically concave to optimize contact area with the curved transverse rod 64.

[0044] In some embodiments, the tops of at least one locking nuts comprise a mating surface for accepting common tools, such as Allen wrench, screwdrivers, or any other common tool. In other embodiments, at least one locking nuts comprise a special mating surface on top that can only be operated by a special tool. In some embodiments, one or

more of the contacting saddles may comprise a stem extending from the top portion. In these embodiments, the corresponding locking nut would have a hole to accommodate the protruding stem on the contacting saddle, so the contacting saddle is properly lined up with the corresponding locking nut. In some embodiments, the configurations of the locking nuts and the contacting saddles may be interchangeable. For example, the complimentary helical surfaces may be on the outer cylindrical wall of the locking nut and the connector body in one embodiment. In another embodiment, the complimentary helical surfaces may be on the bottom of the locking nut and the top of the corresponding contacting saddle. In some embodiments, at least one of the locking nuts and/or contacting saddles may have a different configuration compared to the others.

C. Implantation Procedure

[0045] In some embodiments of the invention, the patient is intubated and general anesthesia is achieved. The patient is prepped and draped in the usual sterile fashion. A posterior approach to the spine is used to expose the posterior vertebral bodies. Many posterior approaches to the vertebral column are described in various medical texts such as Campbell's Operative Orthopaedics, 10th ed., edited by Canale et al., herein incorporated by reference. In some embodiments, the upper cervical spine is accessed. In other embodiments, the lower cervical spine, cervicothoracic junction, thoracic spine, thoracolumbar junction, lumbar region, lumbosacral junction, sacrum or combination of the above regions are accessed.

[0046] The vertebral column is accessed and one or more vertebrae are identified and accessed. In some embodiments, two or more vertebrae are accessed and in still other embodiments, two or more adjacent vertebrae are accessed. A pedicle screw, hook, anchor or other attachment device is attached to a first vertebra. A second attachment device is attached to a second vertebra. The two attachment devices are coupled with a first elongate member 54. In some cases, a second set of attachment devices is then attached to the same vertebrae on the other side of the posterior arch. In other cases, the second set of attachment devices can be attached to different vertebrae. A second elongate member 56 is then used to couple the second set of attachment devices. In some cases, the two elongate members 54, 56

are generally parallel to each other. In other cases, the two elongate members 54, 56 may be at an angle to each other or unlevelled.

[0047] A transverse connector 53, such as one of the embodiments disclosed in the present application, is positioned between the two elongate members 54, 56. The transverse connector 53 can be bent at the articulation between the first connector body 62 and the transverse rod 64 to compensate for convergence or divergence between the two elongate members 54, 56. The projection end 75 of the transverse rod 64 can be rotated within the receiving bore 80 in the second connector body 66 to compensate for the differences in angular orientations of the two elongate members 54, 56 with respect to coronal plane. The transverse rod 64 can also be slideably moved in and out of the receiving bore 80 for adjusting the bridging distance between the two elongate members 54, 56.

[0048] After adjustments are made to properly seat the elongate members 54, 56 into the engaging members 68, 82 of the transverse connector 53, the first and the second locking members 63, 67 are tightened to secure the elongate members 54, 56 to the transverse connector 53. At the same time, the articulation between the first connector body 62 and the transverse rod 64 is also secured or locked at the set angle. The third locking member 65 is also tightened to secure the transverse rod 64 to the second connector body 66 and to lock down the rotational and the sliding movements, so the longitudinal length of the transverse connector 53 and the angular orientation of the two connector bodies are fixed. Lastly, the operative site is irrigated with antibiotics and the operative field is sutured closed.

[0049] Although the present invention has been described in relation to various exemplary embodiments, various additional embodiments and alterations to the described embodiments are contemplated within the scope of the invention. Thus, no part of the foregoing description should be interpreted to limit the scope of the invention as set forth in the following claims. For all of the embodiments described above, the steps of the methods need not be performed sequentially.

WHAT IS CLAIMED IS:

1. A transverse connector for vertebral fixation systems comprising:
 - a first connector body comprising a first engaging member for engaging a first elongate member, and a first locking member;
 - a second connector body comprising a second engaging member for engaging a second elongate member;
 - a transverse rod coupled to the first connector body and the second connector body; and
 - a pivot joint disposed on a first end of the transverse rod and configured to couple with the first connector body;wherein the first locking member is configured to secure both the pivot joint to the first connector body and secure the first connector body to the first elongate member.
2. The transverse connector of Claim 1, wherein the first connector body further comprises a through bore that houses the first locking member and a passage having a first opening in the through bore and a second opening at a medial end of the first connector body.
3. The transverse connector of Claim 2, wherein the passage is configured to receive the pivot joint on the first end of the transverse rod through the second opening at the medial end of the first connector body to form an articulation between the transverse rod and the first connector body.
4. The transverse connector of Claim 3, wherein the first connector body further comprises a pushing member coupled to the first locking member, wherein the pushing member is configured to push against and secure the pivot joint when the first locking member is in a locked position.
5. The transverse connector of Claim 4, wherein the first locking member comprises a side surface that biases the pushing member toward the pivot joint.
6. The transverse connector of Claim 5, wherein the side surface of the first locking member comprises a helical surface.
7. The transverse connector of Claim 5, wherein the side surface of the first locking member comprises a cam surface.

8. The transverse connector of Claim 4, wherein the pushing member is disposed within the passage.

9. The transverse connector of Claim 1, wherein the first locking member comprises a first locking nut, and a first contacting saddle configured to contact and secure the first elongate member to the first connector body when the first locking member is in a locked position.

10. The transverse connector of Claim 9, wherein the first contacting saddle has a helical surface configured for coupling to a complimentary helical surface on the first locking nut.

11. The transverse connector of Claim 1, wherein the second connector body further comprises a receiving bore configured to receive a projection end of the transverse rod.

12. The transverse connector of Claim 11, wherein transverse rod can slideably move in and out of the receiving bore along a longitudinal axis and rotate about the longitudinal axis.

13. The transverse connector of Claim 11, wherein the second connector body further comprises a second locking member configured to secure the second elongate member to the second connector body, and a third locking member configured to secure the projection end of the transverse rod to the second connector body.

14. The transverse connector of Claim 13, wherein the second locking member comprises a second locking nut, and a second contacting saddle configured to contact and secure the second elongate member to the second connector body when the second locking member is in a locked position.

15. The transverse connector of Claim 14, wherein the second contacting saddle has a helical surface configured for coupling to a complimentary helical surface on the second locking nut.

16. The transverse connector of Claim 1, wherein the transverse rod further comprises a retaining pin at a projection end.

17. The transverse connector of Claim 16, wherein second connector body further comprises a groove, wherein the retaining pin is engaged within the groove.

18. The transverse connector of Claim 1, wherein the transverse connector has generally a curved shape to allow for the posterior arch of the vertebral column.

19. The transverse connector of Claim 1, wherein at least one of the first and the second connector bodies is a rod connector.

20. The transverse connector of Claim 1, wherein at least one of the first and the second engaging members comprises a hook end.

21. The transverse connector of Claim 1, further comprising:
a coupling surface on a portion of the pivot joint; and
a complimentary coupling surface on a portion of the first connector body;
wherein when the coupling surfaces are coupled, the transverse rod and the first connector body maintain an angular orientation in relation to each other.

22. The transverse connector of Claim 21, wherein the coupling surfaces comprise abrasive surfaces.

23. A transverse connector for vertebral fixation systems comprising:
a connector body configured to engage an elongate member and comprising a locking member;
a transverse rod; and
a pivot joint disposed on an end of the transverse rod and configured to couple with the connector body;
wherein the locking member is configured to secure the pivot joint to the connector body and secure the connector body to the elongate member.

24. A method of implanting a vertebral fixation device, the method comprising the steps of:
coupling a first connector body of a transverse connector with a first elongate member;
positioning a transverse rod in angular relation to the first connector body; and
actuating a first locking member to secure both the transverse rod to the first connector body and the first connector body to the first elongate member.

25. The method of implanting a vertebral fixation device of Claim 24, further comprising the steps of:

coupling a second connector body of the transverse connector with a second elongate member before actuating the first locking member;

actuating a second locking member to secure the second connector body with the second elongate member.

26. The method of implanting a vertebral fixation device of Claim 24, further comprising the steps of:

positioning the transverse rod in relation to the second connector body by sliding the transverse rod in or out of the second connector body and/or by rotating the transverse rod about a longitudinal axis of the transverse rod;

actuating a third locking member to secure the transverse rod to the second connector body.

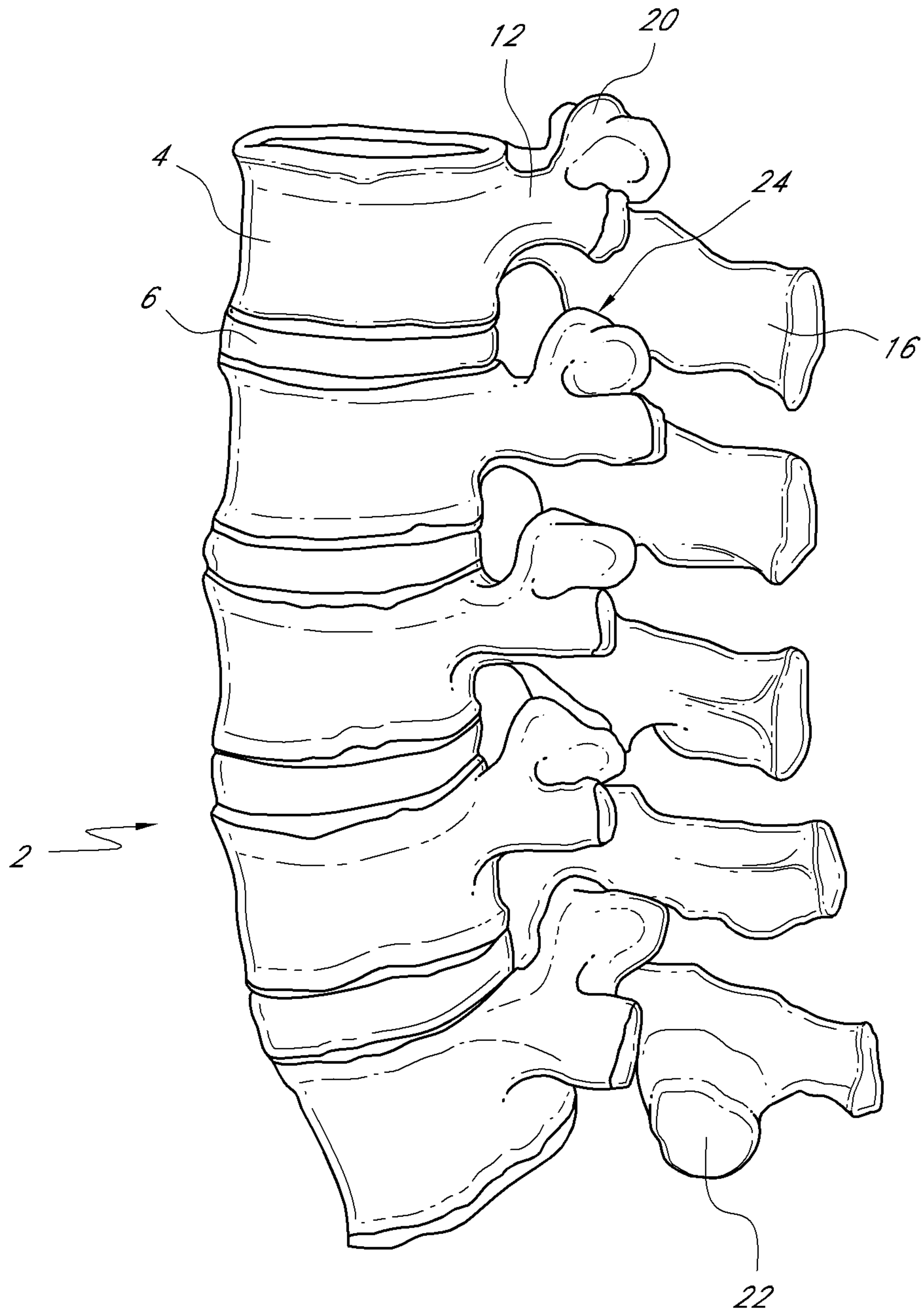

FIG. 1

FIG. 2A

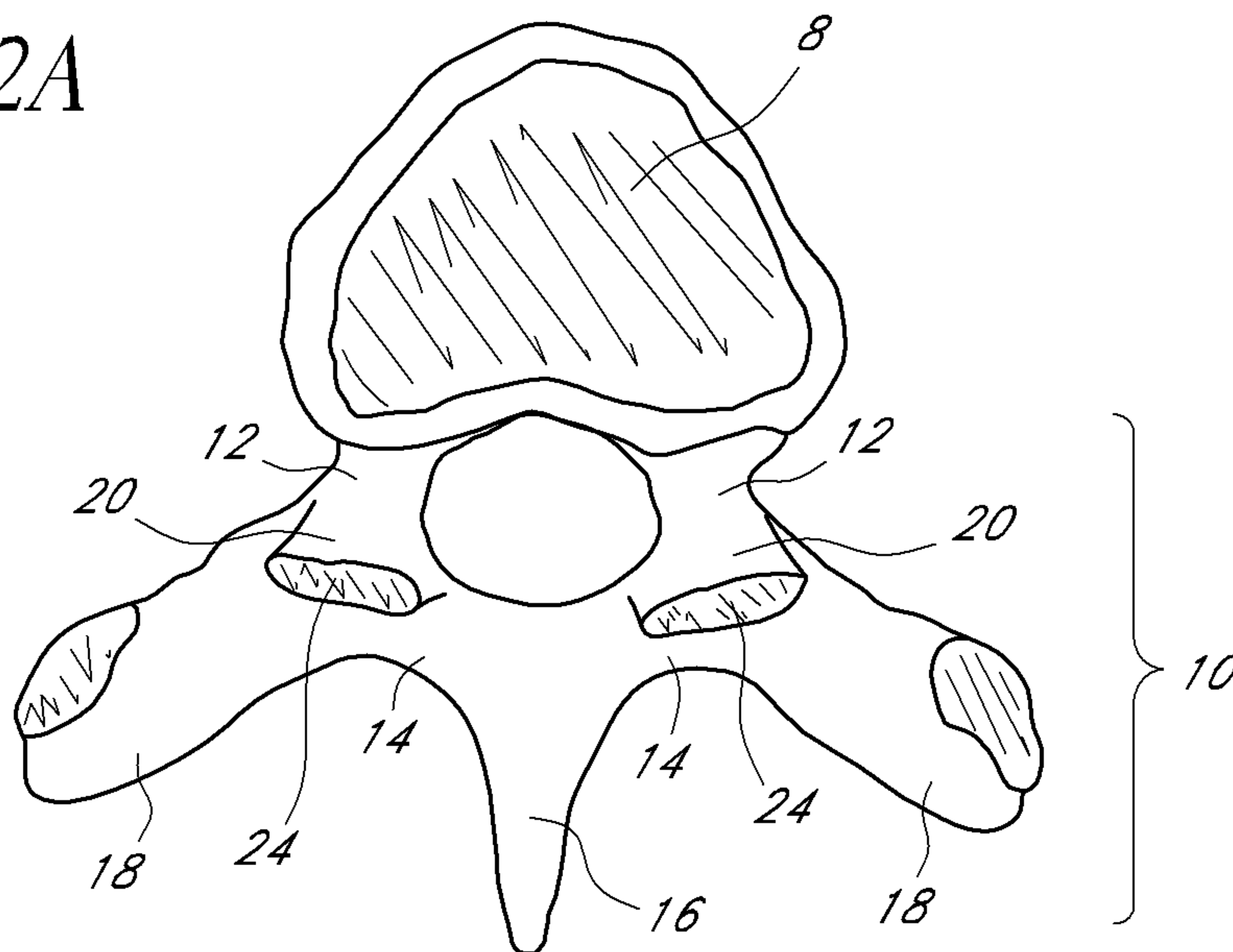
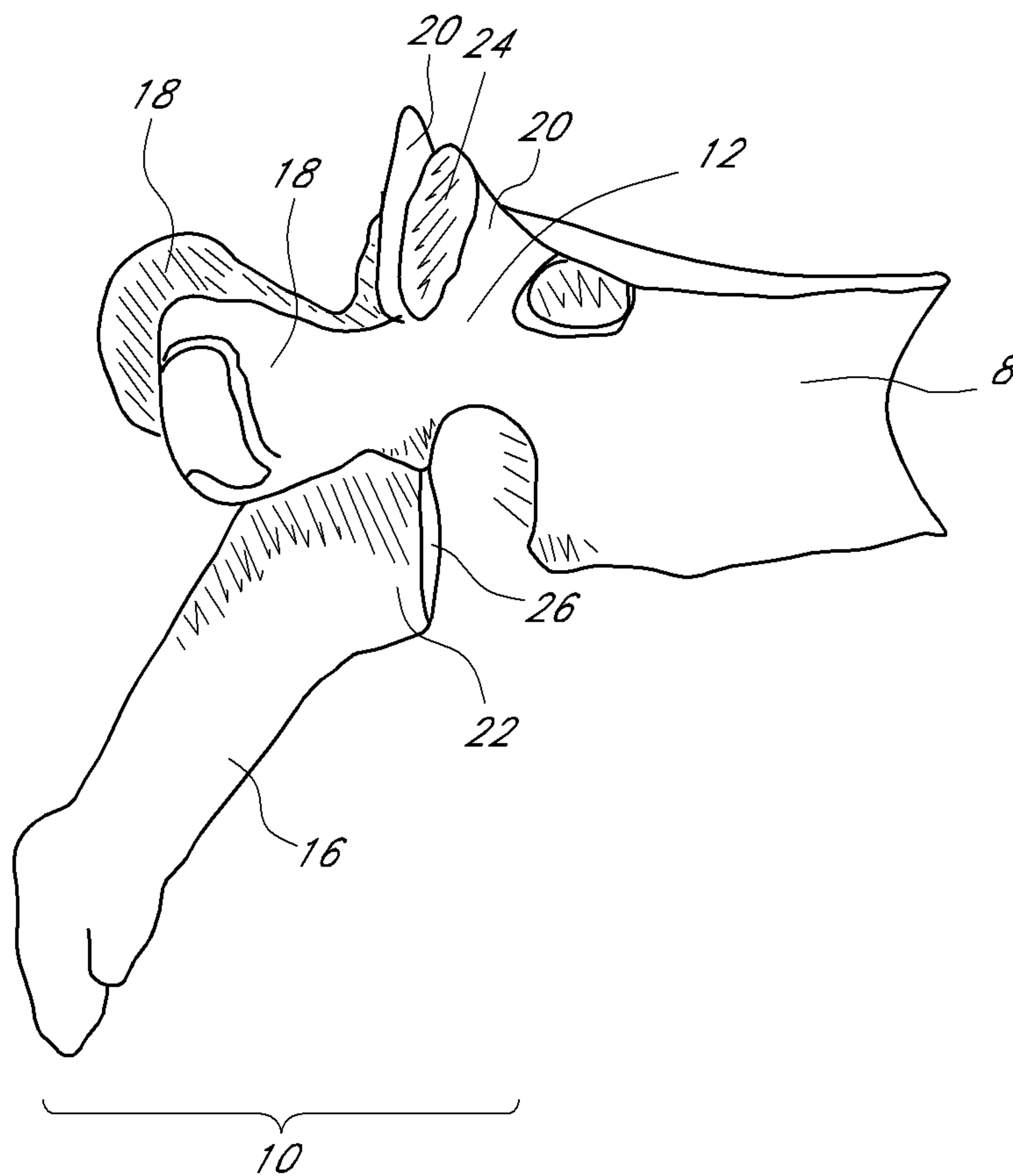

FIG. 2B



3/9

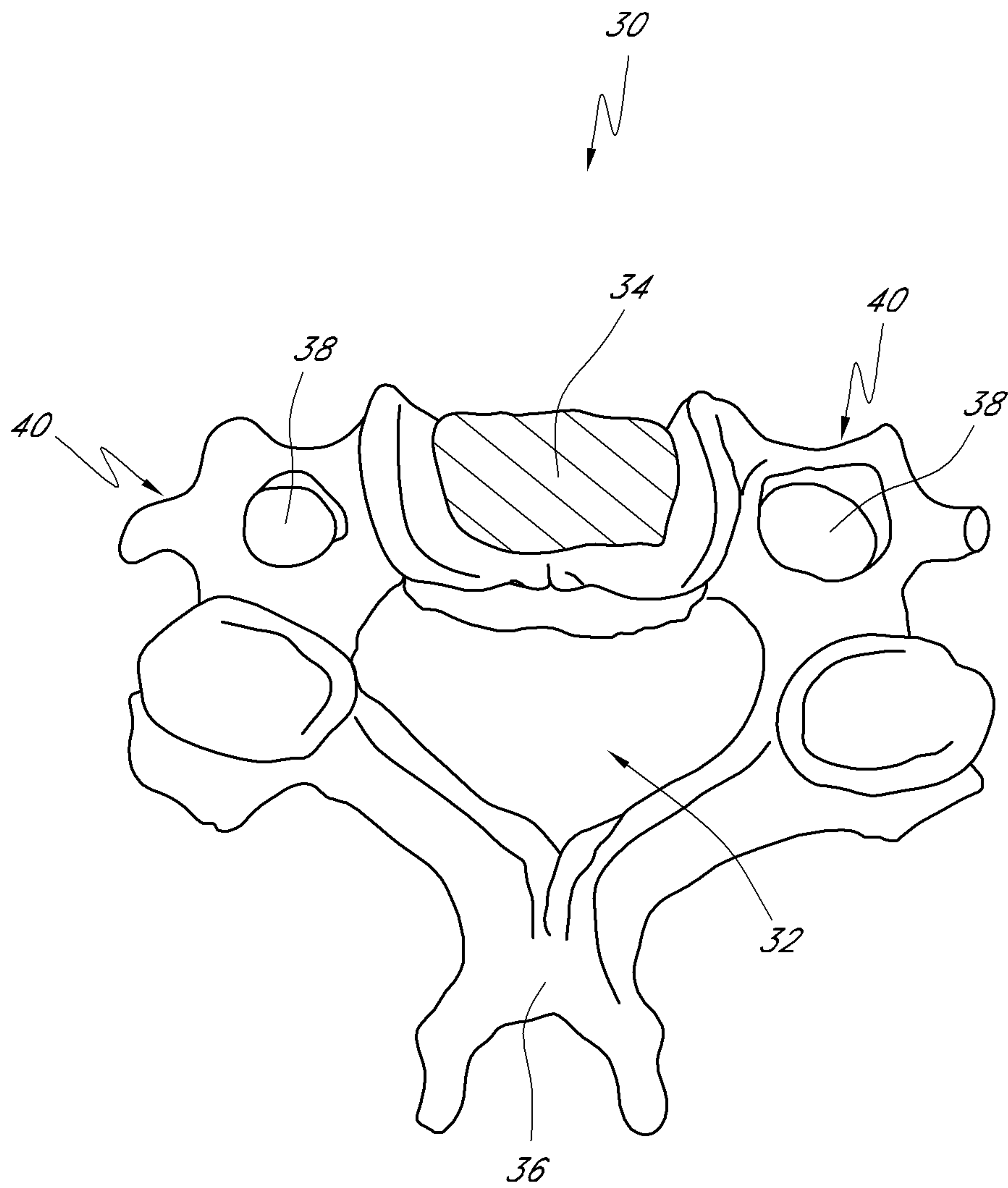

FIG. 3

4/9

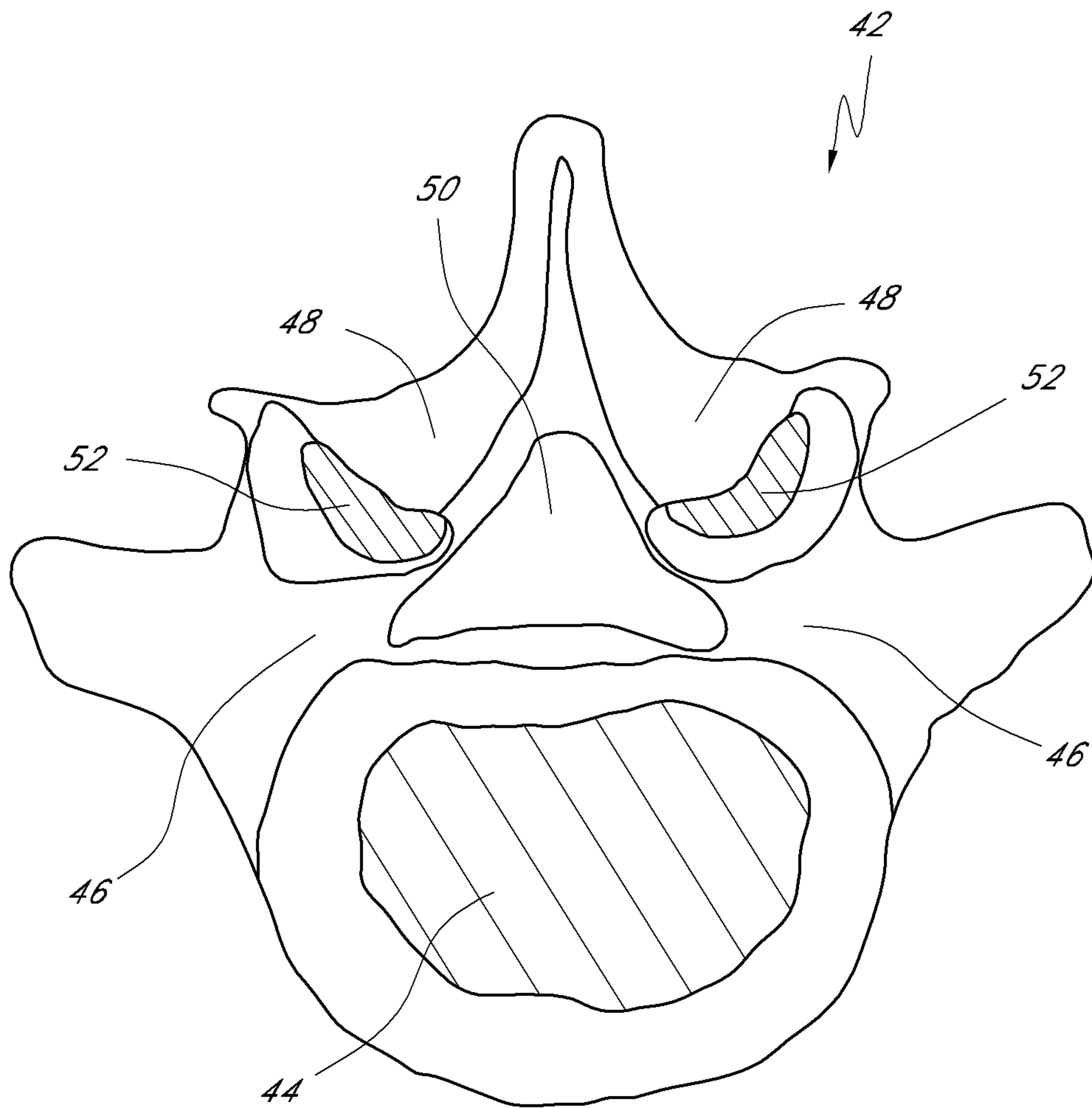

FIG. 4

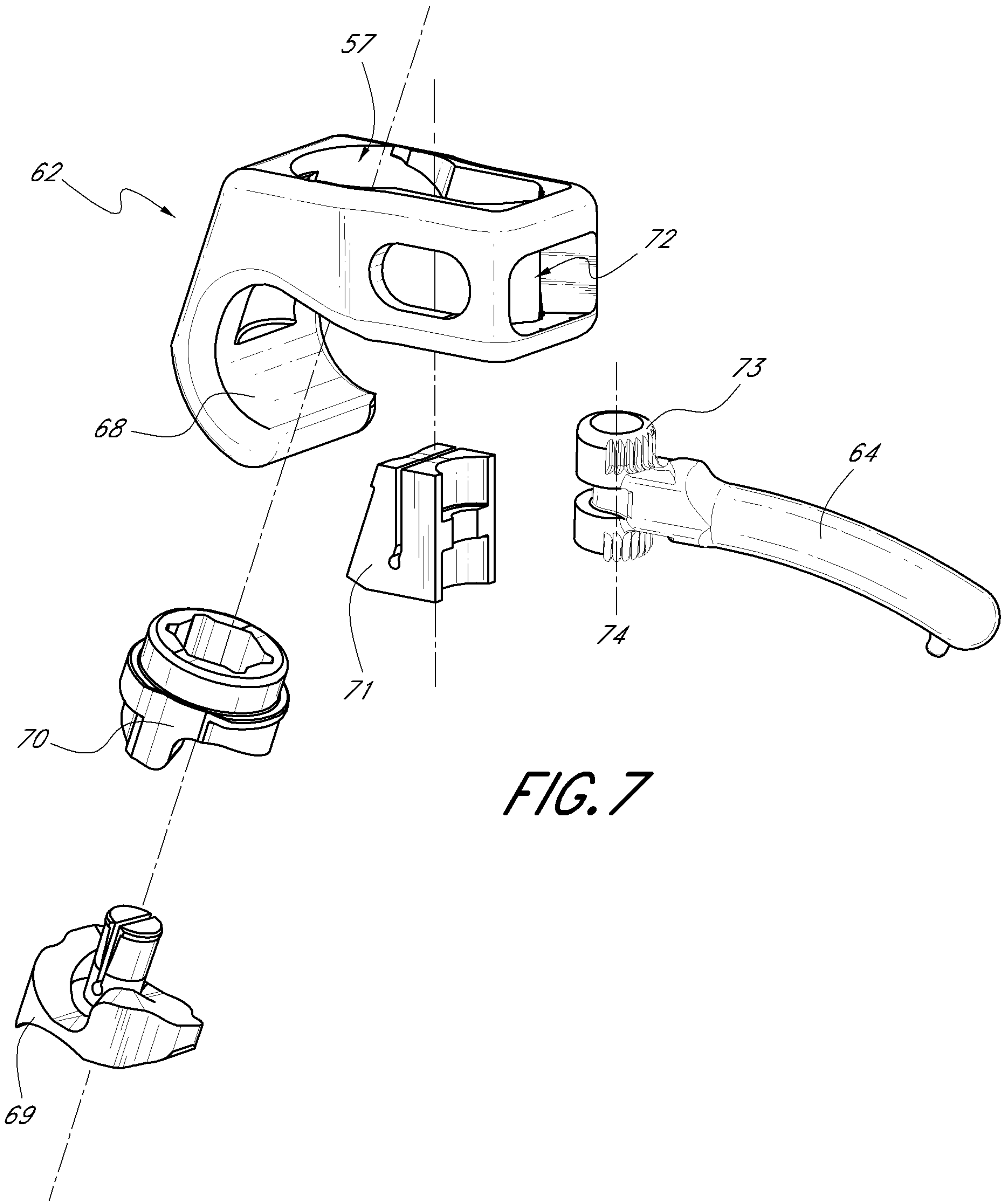

FIG. 7

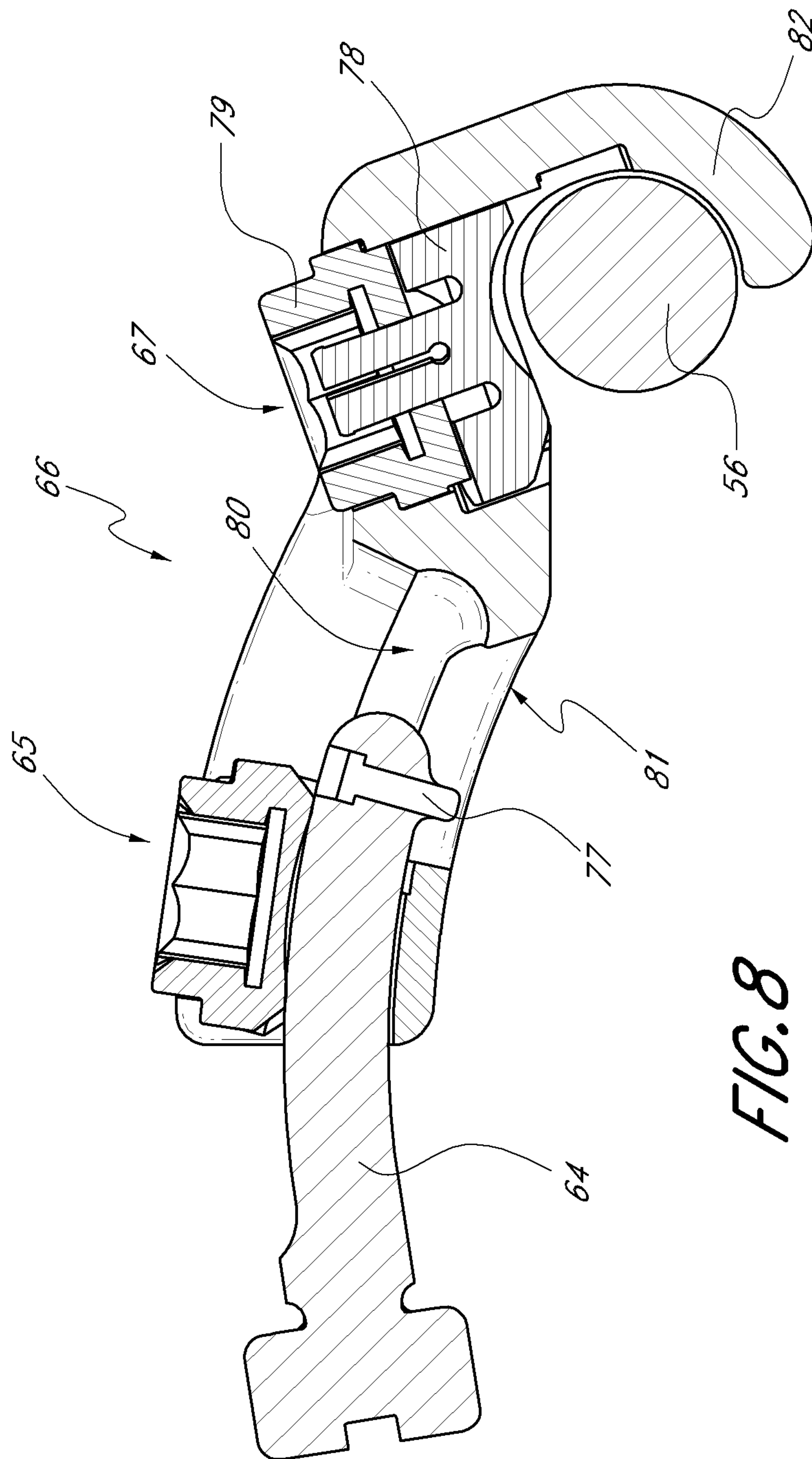

FIG. 8

9/9

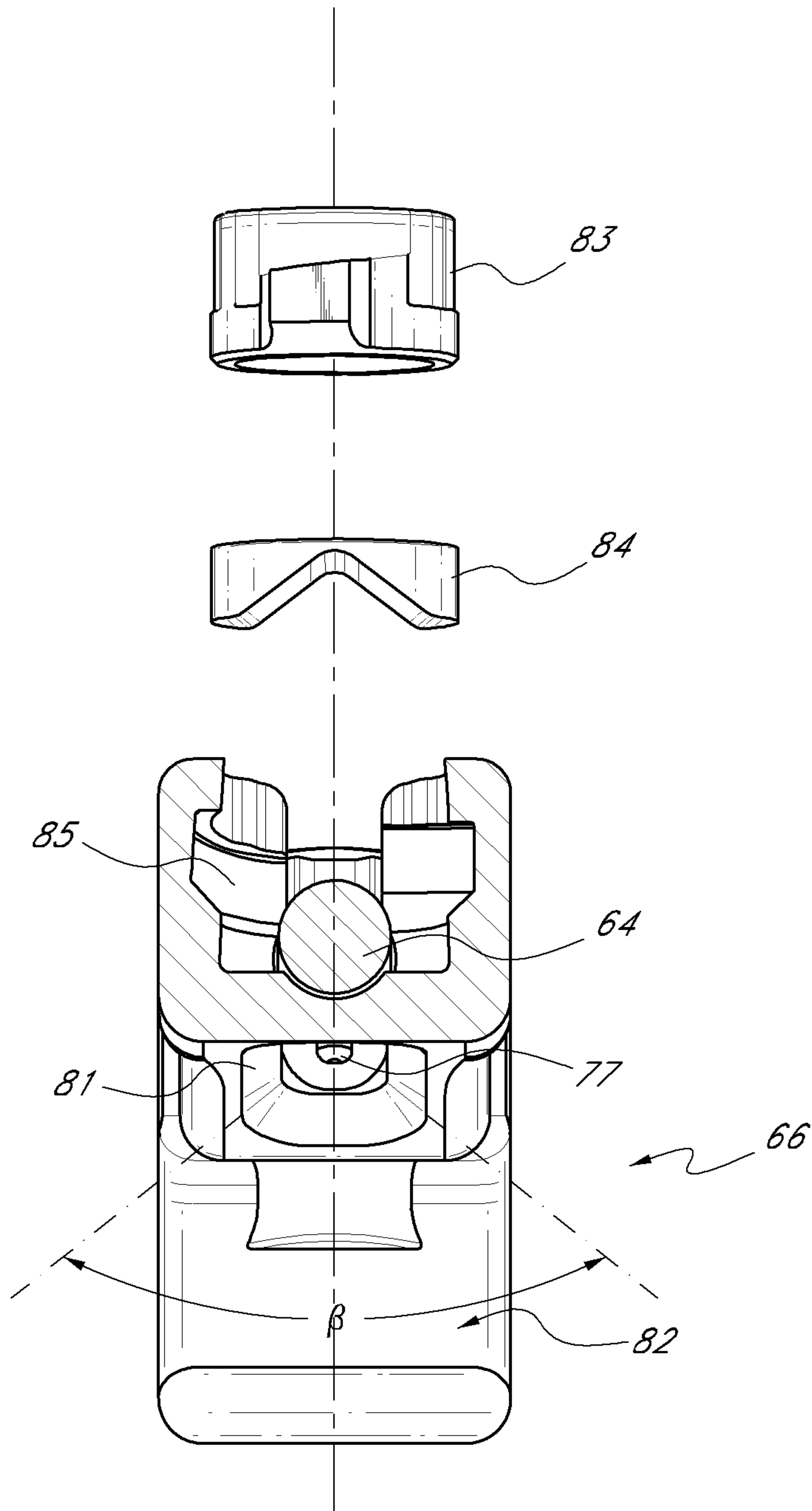

FIG. 9

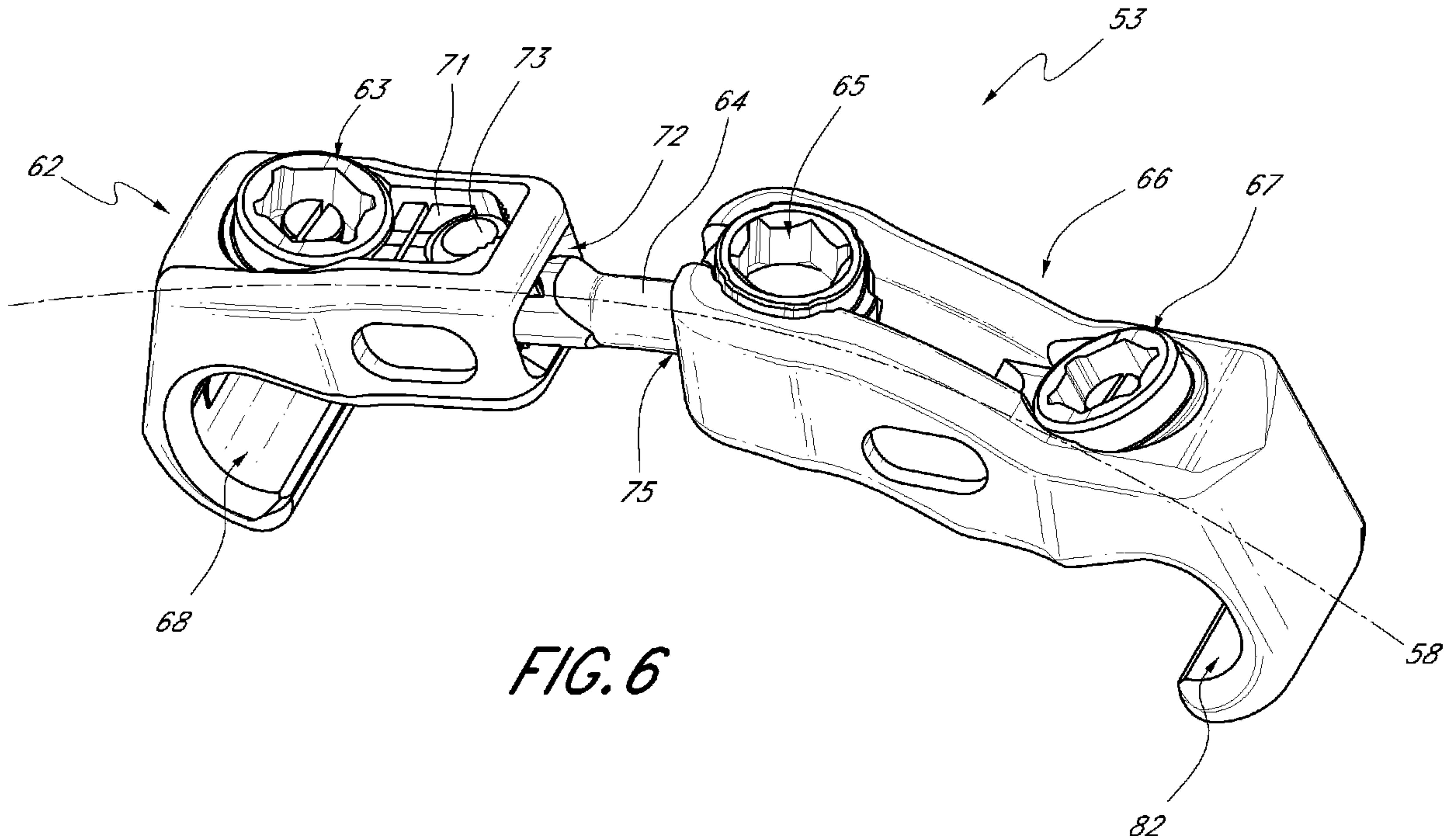

FIG. 6