

(19) World Intellectual Property Organization
International Bureau



(43) International Publication Date
17 July 2008 (17.07.2008)

PCT

(10) International Publication Number
WO 2008/085164 A1

- (51) **International Patent Classification:**
H02G 1/04 (2006.01) H02G 7/00 (2006.01)
- (21) **International Application Number:**
PCT/US2007/000607
- (22) **International Filing Date:** 10 January 2007 (10.01.2007)
- (25) **Filing Language:** English
- (26) **Publication Language:** English
- (30) **Priority Data:**
11/621,518 9 January 2007 (09.01.2007) US
- (71) **Applicant and**
- (72) **Inventor:** BARTHOLD, Lionel, O. [US/US]; 10 Wood's Point Lane, Lake George, NY 12845 (US).
- (74) **Agents:** DINGMAN, Brian, M. et al.; Mirick O'Connell DeMallie & Lougee, LLP, 1700 West Park Drive, Westborough, MA 01581-3941 (US).

- (81) **Designated States** (unless otherwise indicated, for every kind of national protection available): AE, AG, AL, AM, AT, AU, AZ, BA, BB, BG, BR, BW, BY, BZ, CA, CH, CN, CO, CR, CU, CZ, DE, DK, DM, DZ, EC, EE, EG, ES, FI, GB, GD, GE, GH, GM, GT, HN, HR, HU, ID, IL, IN, IS, JP, KE, KG, KM, KN, KP, KR, KZ, LA, LC, LK, LR, LS, LT, LU, LV, LY, MA, MD, MG, MK, MN, MW, MX, MY, MZ, NA, NG, NI, NO, NZ, OM, PG, PH, PL, PT, RO, RS, RU, SC, SD, SE, SG, SK, SL, SM, SV, SY, TJ, TM, TN, TR, TT, TZ, UA, UG, US, UZ, VC, VN, ZA, ZM, ZW.
- (84) **Designated States** (unless otherwise indicated, for every kind of regional protection available): ARIPO (BW, GH, GM, KE, LS, MW, MZ, NA, SD, SL, SZ, TZ, UG, ZM, ZW), Eurasian (AM, AZ, BY, KG, KZ, MD, RU, TJ, TM), European (AT, BE, BG, CH, CY, CZ, DE, DK, EE, ES, FI, FR, GB, GR, HU, IE, IS, IT, LT, LU, LV, MC, NL, PL, PT, RO, SE, SI, SK, TR), OAPI (BF, BJ, CF, CG, CI, CM, GA, GN, GQ, GW, ML, MR, NE, SN, TD, TG).

Published:
— with international search report

(54) **Title:** SYSTEMS, METHODS AND APPARATUS FOR TRANSMISSION LINE RE-CONDUCTORING

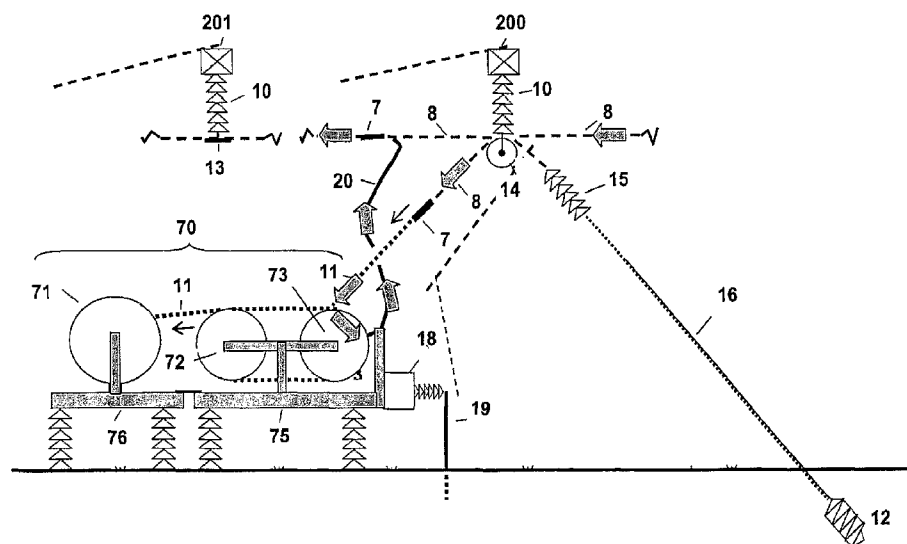

(57) **Abstract:** A method and associated equipment for replacing existing overhead transmission line conductors with new ones while the transmission line remains in service and carrying power. The invention uses the old conductor to pull the new conductor through a series of sheaves installed at the bottom of each tower insulator. Conventional tension-stringing principles are used to assure that both the old and new conductors maintain a safe distance from ground. To achieve this, both the pulling and tensioning (braking) equipment, as well as supply and take-up reels or drums may be elevated to power line voltage and the current is transferred between new conductor and old, while in transit to the line, by means of a brush system and a conducting wheel which may or may not be integral with pulling and tensioning equipment.



WO 2008/085164 A1

**SYSTEMS, METHODS AND APPARATUS FOR
TRANSMISSION LINE RE-CONDUCTORING**

Cross Reference to Related Application

5 This application claims priority of Provisional Patent Application Serial
Number 60/757,644 filed January 10, 2006, the disclosure of which is
incorporated herein by reference.

Field of the Invention

10 This invention pertains to the installation of electrical cables or conductors
onto towers of high voltage electric power lines. More specifically, the invention
is directed to the installation of new conductor s by using the existing or old
conductor to draw the replacement or new conductor into place. The invention
also permits the replacement operation to be carried out while the electric power
15 line remains in service and energized at high voltage. The invention draws on
methods and equipment already in use and well defined in the prior art for
working on high voltage lines while the lines are energized, referred to in the
trade as “live-line maintenance.”

20

Background of the Invention

In many electric power networks, the growth in generating capacity has
outstripped the growth in construction of new transmission lines. This has caused
power system design specialists to seek ways to allow existing transmission lines

to carry more power. One means of doing so is the replacement of old
conductors with new conductors of higher current-carrying capacity. The new
conductors may simply be larger if the towers are capable of carrying the extra
weight and wind loading. Where the towers are not capable of doing so, special
5 conductors capable of carrying more current with the same or less elongation are
now available. These special conductors allow operation at a much higher
temperature without posing a safety hazard by exceeding sag limits.
Unfortunately, the lines which are the most urgent candidates for re-conductoring
are also those which are the most difficult to remove from service, a problem
10 which this invention addresses.

Description of the Prior Art

The field of prior art deals largely with methods and equipment for putting
transmission line conductors into place (stringing) before a line has been
commissioned and energized with voltage. The prior art has evolved to the point
15 where it is common to transfer the conductor directly from the conductor supply
reel to its overhead position by means of a transportable “tensioner” or brake at
the conductor supply end and a transportable “puller” or winch at the conductor
pulling end. The tensioner provides sufficient resistance to the pulling force to
assure that the conductor does not touch the ground, thus avoiding nicks and
20 scratches that are sources of electrical discharges or corona once the conductor is
energized. Tension stringing equipment is supplied by a number of commercial
enterprises, e.g., TSE International of Shreveport, Louisiana. ([www.tse-
international.com](http://www.tse-international.com)). Procedures are well established and documented, as for

example in the reference IEEE Guide to the Installation of Overhead Transmission Line Conductors, Product No: SH95170.

FIG. 1 illustrates the context of a conventional prior art conductor stringing operation which, in this case is presumed to proceed from right to left.

5 It presumes that tower 100 and all towers to the right of tower 100 have been strung and attached to the bottom of insulator strings 10 with permanent clamps 13. It presumes that a section of line between towers 101 and 200 is now to be strung and that tower 201 and those to the left of tower 201 will be strung in a subsequent stringing operation. Towers 100 and 101 are adjacent to one another,
10 as are towers 200 and 201. Stringing blocks 14 have been affixed to the bottom of insulator strings 10 on towers 101 through 200, and a lead cable 11 has been threaded through them in preparation for stringing. Stringing blocks 14 have two sheaves per conductor at the terminating towers, 101 and 200, one sheave per conductor on intermediate towers (not shown).

15 In FIG. 2, the conductor 4, already installed on the line section to the right of tower 100 been temporarily tied to anchor 12 to sustain tension. New conductor 4 is now being fed from the supply reel 61 of tensioner 60, pulled into place onto tower 101 and the line section between tower 101 and 200 by means of lead cable 11 which is being pulled from the tower 200 position, not shown in this
20 figure. The tensioner 60 must maintain sufficient tension to prevent the new conductor 4 from sagging to the ground between adjacent spans of the line section 101 to 200. The new conductor 4 is connected to lead cable 11 by means of prior art coupler 7. The exact length of the pull represented by section 101 to 200 will

depend on the amount of conductor on supply reel **61** but is typically 5,000 to 15,000 feet. In the process of replacing stringing blocks **14** by permanent clamps **13** the exact sag of each span between towers has been adjusted to its design value.

5 FIG. 3 shows the pulling end of the prior art operation illustrated in FIG. 2. In FIG. 3, new conductor **4** has already been pulled through stringing blocks (not shown) on all towers between **101** and **200**, but has not yet been pulled through tower **200**. Puller **70** consists of an engine (not shown) that drives one or more bull wheels **72** and **73** around which lead cable **11** makes multiple turns so
10 as to gain the friction needed for the pulling function. Lead cable **11** is coiled around take-up reel **71** for reuse on the next pulling section.

 Bull wheels **62** and **63**, and supply reel **61**, of tensioner **60** shown in FIG. 1, are typically mounted on special vehicles, which are prior art with respect to conductor installation practice. For purposes of this illustration they are shown in
15 FIG. 2 simply as platforms **65** and **66**. Similarly, bull wheels **72** and **73**, and take-up reel **71**, of puller **70** in FIG. 3 are also typically mounted on prior art special vehicles but are shown in the figure as simply platforms **75** and **76**. Platforms **75** and **76** may be mounted on one and the same vehicle.

 In addition to the above prior art, dealing with un-energized transmission
20 lines, there is a field of prior art dealing with “live-line” work; specifically change-out or repair of transmission line insulators and hardware while the line continues to be energized. Live-line maintenance and repair takes advantage of a variety of tools and equipment, including personnel “buckets” which can be

elevated to conductor level on insulated booms, in which case the bucket is caused to be at the same potential as the conductor or hardware, allowing maintenance personnel to safely put themselves in direct contact with the conductor or hardware. These techniques and equipment have also been used to
5 adjust the sag of existing lines while they remain energized, as documented, for example, in the reference, R.C. Black and R. S. Throop, "A Live Line Method for Retensioning Transmission Line Conductors" CIGRE paper 22-10, 1970.

Only recently have means been proposed to replace the conductors over a long line section while a transmission line is still energized. US Patent
10 application publication 20050133244 suggests doing so by putting in place a spare conductor, paralleling the power line, onto which power can be diverted while a formerly active conductor, no longer under high voltage, can be replaced. This method has the disadvantages of: (a) requiring the installation of temporary towers the full length of the line section being strung; and (b) still requiring safety
15 precautions due to the voltage and current inductively coupled to new conductor as it is being strung.

Economic incentives for increasing the transmission capacity of existing power lines suggest that more efficient and more economical means be devised to replace energized conductors, particularly since the power lines for which the
20 greatest incentive for conductor replacement exists are apt to be those which are hardest to remove from service for conductor replacement.

Summary of the Invention

The invention comprises systems, methods, and equipment to allow an old or existing transmission line conductor to serve as the lead cable to draw a new or replacement conductor into place in its stead while, in one embodiment, both conductors and the line itself continue to carry full current under full voltage.

5 In this embodiment the supply reel of new conductor and associated tensioner are insulated from ground and maintained at line potential, as is the take-up reel and associated puller.

The invention differs from prior art in that it describes equipment modifications, auxiliary equipment, and methods by which the old conductor can
10 be cut, tied to the new conductor, and used as a lead cable to pull the new conductor into place. In the preferred embodiment, the invention may achieve the replacement while providing a continuous path for current to flow over the line section being replaced, thus causing no interruption of power flow. In another embodiment, the invention may achieve the replacement by restricting the power
15 interruption to a very short duration.

For uninterrupted re-stringing, the transfer of current from one conductor to another, at both the tensioning and pulling ends of the operation, is achieved by causing the conductor to make one or more turns around a conducting wheel from which it receives current. The wheel, which rotates as the conductor is pulled,
20 receives its current from a system of brushes tied, in turn, to the fixed conductor at either end of the re-conductoring section.

Brief Description of the Drawings

Other objects, features and advantages will occur to those skilled in the art from the following description of the preferred embodiments of the invention, and the accompanying drawings, in which:

FIG. 1 illustrates a series of transmission line towers, some of which are to
5 be strung or restrung;

FIG. 2 illustrates the tensioning end of a prior art tension stringing operation;

FIG. 3 illustrates the pulling end of the prior art tension stringing operation shown in FIG. 2;

10 FIG. 4 illustrates an overview of the preferred embodiment of the invention;

FIG. 5 illustrates Step 1 of the preparation at the pulling end for a live-line tension stringing operation, according to the preferred embodiment of the invention;

15 FIG. 6 illustrates Step 2 of the preparation at the pulling end for a live-line tension stringing operation, according to the preferred embodiment of the invention;

FIG. 7 illustrates Step 3 of the preparation at the pulling end for a live-line tension stringing operation, according to the preferred embodiment of the
20 invention;

FIG. 8 illustrates an insulated puller in place, according to the preferred embodiment of the invention;

FIG. 9 illustrates the current flow through the insulated puller shown in FIG. 8;

FIG. 10 illustrates an insulated puller near completion of the pull, according to the preferred embodiment of the invention;

5 FIG. 11 illustrates Step 1 of a live-line puller disengagement, according to the preferred embodiment of the invention;

FIG. 12 illustrates Step 2 of a live-line puller disengagement, according to the preferred embodiment of the invention;

10 FIG. 13 illustrates Step 3 of a live-line puller disengagement, according to the preferred embodiment of the invention;

FIG. 14 illustrates Step 4 of a live-line puller disengagement, according to the preferred embodiment of the invention;

FIG. 15 illustrates the completion of a live-line puller disengagement, according to the preferred embodiment of the invention;

15 FIG. 16 illustrates Step 1 of the preparation at the tensioning (supply) end for a live-line tension stringing operation, according to the preferred embodiment of the invention;

20 FIG. 17 illustrates Step 2 of the preparation at the tensioning (supply) end for a live-line tension stringing operation, according to the preferred embodiment of the invention;

FIG. 18 Illustrates Step 3 of the preparation at the tensioning (supply) end for a live-line tension stringing operation, according to the preferred embodiment of the invention;

FIG. 19 illustrates an insulated tensioner in place, commencing the live-line pull, according to the preferred embodiment of the invention;

FIG. 20 illustrates the current flow through the insulated tensioner shown in FIG. 19;

5 FIG. 21 illustrates a portion of bull wheels dedicated to current transfer;

FIG. 22 illustrates the auxiliary reactor connection for over-current protection;

FIG. 23 illustrates the bypass contactor and protective gap for over-current protection;

10 FIG. 24 illustrates an electrical equivalent of over-current protection scheme;

FIG. 25 illustrates an alternative embodiment of the invention with a dedicated contactor wheel and pressure wheels;

15 FIG. 26 illustrates an alternative embodiment of the invention with a dedicated contactor wheel and wheel-mounted clamps;

FIG. 27 illustrates an example mid-span current transfer device embodiment of the invention;

FIG. 28 illustrates a schematic of a current transfer wheel and brush assembly;

20 FIG. 29 illustrates Step 1 in use of the mid-span current transfer device;

FIG. 30 illustrates the midspan current transfer device used in conjunction with a puller;

FIG. 31 illustrates the midspan current transfer device used in conjunction with a tensioner;

FIG. 32 illustrates an example embodiment of the device on one or more truck beds;

5 FIG. 33 illustrates an example of the insulated ramp to allow use of conventional tensioners and pullers adapted to use the invention;

FIG. 34 illustrates an example of the collapsible platform to support the tensioning and pulling equipment;

10 FIG. 35 illustrates an example of an access bucket to the energized platform;

FIG. 36 illustrates a schematic of a means to achieve hot-line stringing on poles or towers of vertical configuration;

FIG. 37 illustrates an embodiment of the invention achieving limited interruption time restringing using prior art pullers and tensioners; and

15 FIG. 38 illustrates a system for detecting a stuck sheave.

Detailed Description of Preferred Embodiments of the Invention

The System

The following paragraphs describe a number of operations that may be conducted at line potential. None of these operations are believed to be outside
5 the procedural and/or equipment capability of conventional “live-line maintenance” procedures. These procedures may be carried out from trucks with insulated booms, commonly used in transmission line maintenance and repair, or, in the case of operations in close proximity to the tower, by live-line tools designed for use from a grounded position.

10 FIG. 4 provides a simplified schematic diagram of the preferred embodiment of the invention, a system in which an old or existing high-voltage conductor is used to pull a new or replacement high-voltage conductor into place in its stead. FIG. 4 shows both the first tower **101** and the last tower **200** of the line section over which the previous conductor is to be replaced. Double sheave
15 stringing blocks **14**, have been attached to towers **101** and **200**. Similar blocks with one sheave per conductor have been installed on intermediate towers. FIG. 4 also shows a tensioner or similar device **60** that is used to supply the new conductor **4**, and a puller or similar device **70** that is used to take up the old conductor **8**. New conductor **4** is attached to the old conductor **8** by the use of a coupler or similar
20 device **7**. Puller **70** is used to pull old conductor, **8** which in turn pulls new conductor **4** into place through stringing blocks **14**. The high-voltage line may remain energized during the replacement operation and current may continue to be carried as illustrated by the “Current In” and “Current Out” arrows.

The details of the preferred embodiment can best be understood by illustrating preparations for the connection of the tensioner and the puller assemblies and the conductor replacement operation. This will first be done for the pulling end (tower **200**) and then the tensioning end (tower **101**), though both may
5 be undertaken simultaneously.

The Pulling End

In FIG. 5 an auxiliary insulator **15**, temporary guy **16**, and temporary anchor **12** have been attached to the old conductor **8** by means of a coupler **7** and made to
10 draw up tension using a prior art winch or come-along (not shown), pulling conductor **8** to the right and down through stringing block **14**.

In FIG. 6 a lead cable **11** has been threaded through a second sheave on stringing block **14** and attached to the old conductor **8** somewhat to the right of the point at which the anchor assembly **15**, **16**, **12** are attached. The lead cable **11** in this
15 case is capable of carrying full line current. The lead cable **11** in FIG. 6 has been pulled to take up slack.

In FIG. 7 the section of old conductor indicated as **A** in FIG. 6 has been cut out of place, leaving the lead cable **11** carrying the full tension of the conductor to the right of tower **200**. The anchor assembly **15**, **16**, **12** in turn is carrying the full
20 tension of the conductor to the left of tower **200**.

FIG. 8 shows a schematic of the puller **70** which supplied the lead cable **11** in FIG. 6 and FIG. 7. Note that prior to the operations cited in those figures, a jumper lead **20** has been connected from the bull wheel **73** to the old conductor **8** by

means of a coupler 7 immediately to the left of tower 200, thus providing a path for current from the old conductor 8 to the right of tower 200, through the lead cable 11, through a portion of the bull wheel 73 and to the old conductor 8 on the line section to the left of tower 200, not yet a part of the restringing operation. FIG.

5 9 shows that current path.

FIG. 10 shows the same configuration as in FIG. 8 and FIG. 9, but near the end of the pulling operation. The new conductor 4 has been pulled through stringing blocks 14 over the entire length of the pulling section from tower 101 to tower 200. The new conductor 4 must now be connected to the old conductor 8 to the left of tower 200 in order that the pulling equipment can be removed. FIGS. 11 – 15 illustrate an example means by which the old and new sections of conductor can be connected pending set up for a new pulling section. FIG. 11 shows a detail of the line connections of FIG. 10 but with two points, X and Y identified; points to which a tensioning device will be attached.

15 FIG. 12 presumes that a live-line tensioning device (prior art and not shown) has drawn points X and Y closer together, thus creating slack in that segment of old conductor 8 and the new conductor 4 which pass through double-sheave stringing block 14.

20 FIG. 13 shows that the slack segment of the old conductor 8, which was formerly tied to the auxiliary insulator 15, has been permanently clamped to new conductor 4 to the right of tower 200 by coupler 7, thus providing a direct path for current and allowing removal of the brush feed cable 20.

FIG. 14 shows the same condition but with the tensioning device relaxed and removed, leaving the left hand portion of the new conductor 4 slack and, in FIG. 15, removed. This leaves the section of line to the left of tower 200 ready for restringing in the same manner.

5 The Tensioning End

The foregoing paragraphs illustrated an embodiment of the invention from the pulling end, i.e. tower 200. A similar procedure may be used at the tensioning end, i.e. at the first tower in the pulling section, tower 101. FIG. 16 shows the initial preparation corresponding to that of FIG. 5 for the pulling end. It presumes
10 that new conductor 4 has already been installed on towers 100 and all those to the right of tower 100. Once again the temporary guy assembly 15, 16, 12 is made to pull the conductor 4 to the left and downward through the stringing block 14 by means of a prior art winch or come-along. In FIG. 17 the end of a new reel of new conductor 4 has been fed from right to left through the stringing block 14 and
15 attached to the old conductor 8 by means of a coupler 7 to the left of the point of attachment of the temporary guy assembly 15, 16, 17.

In FIG. 18 the section of old conductor 8 designated as A in FIG. 17 has been cut away leaving the section of new conductor 4 to the left of tower 101, the section already restrung, supported in tension solely by the temporary guy
20 assembly 15, 16, 12, and the section to the left of tower 101, the section to be restrung, supported in tension solely by the tensioner 60 a more detailed illustration of which is given in FIG. 19. As the puller, described in previous paragraphs, pulls the old conductor through stringing blocks over the line section,

defined here by towers 101 to 200, a reel of new conductor 61, being attached to the old conductor 8 by coupler 7, is fed onto that line section. As in prior art conventional tension stringing, the tensioner maintains sufficient tension during the pulling operation to prevent the conductor from sagging to unsafe levels while the restringing is taking place. FIG. 20 illustrates the path of current during the operation cited above.

Once the conductor has been pulled over the entire length of the pulling section; i.e. from tower 101 to tower 200, tying off procedures identical to those illustrated in FIGS. 11-15 for the pulling end can be used at the tensioning end. In this case the coupler 7 may differ in design since it will be a permanent part of the restrung line.

Insulated Pulling and Tensioning Equipment

FIGS. 19 and 20 show that, in one embodiment of this invention the supply reel 61, and bull wheels 62 and 63, of tensioner 60, and all associated motors, brakes, and auxiliary equipment, may be at full line voltage. They are shown mounted here on insulated platforms 65 and 66, which are described later. Attached to platforms 65 and 66, which may be combined as one, is rapid grounding switch 18 that in turn is connected to ground via ground connector 19. Rapid grounding switch 18 may be operated by a line tension sensor (not shown) so as to immediately short-circuit the conductor and cause the line be tripped out of service by circuit breakers (not shown) at either end in the event that the tension drop indicates loss of control of conductor clearance to ground. These breakers will operate in less than one half second, before a broken conductor

would hit the ground, thus protecting both the stringing crew and the general public from high voltage contact.

FIGS. 8, 9 and 10 shows that the take-up reel 71, and bull wheels 72 and 73, of puller 70, and all associated motors, brakes and auxiliary equipment, may also be at full line voltage. They are shown here mounted on insulated platforms 75 and 76, which are described later. As with the tensioner discussed above, a rapid grounding switch 18 is attached to platforms 75 and 76, which may be combined as one, to ground by ground connector 19. For the sake of personnel safety both the tensioning and pulling platforms 60 and 70 and all associated equipment may be surrounded by a metallic fence mounted on a high-conductivity ground mat, well connected to ground. Other safety issues are described in later paragraphs.

Current Transfer Methods

FIG. 21 shows an embodiment of the invention in the form of specially designed bull wheels of the general form used in the tensioner 60 shown in FIGS 19 (bull wheels 62 and 63) and in the puller 70 shown in FIG. 8 (bull wheels 72 and 73). While only bull wheels 62 and 63 are shown in FIG. 21, the following discussion is similarly applicable to bull wheels 72 and 73.

There are two sections to each bull wheel: a friction section and a conducting section. The friction section of bull wheels 62 and 63 (labeled 62a and 63a), is dedicated to maintaining friction for tensioning. The conducting section of bull wheels 62 and 63 (labeled 62b and 63b), is dedicated to gaining good electrical contact between new conductor 4 and bull wheels 62 and 63.

Grooves in the friction section may typically be lined with plastic material to improve friction and prevent mechanical wear of the wheels. Grooves in the conducting section may typically be lined with a conducting liner. The conducting section **62b** and **63b** of bull wheels **62** and **63** may be made with a slightly larger diameter to provide a degree of “wiping” action to enhance contact. The liner in the conducting sections may typically see considerable wear and should be designed for convenient periodic replacement.

FIG. 21 further illustrates a brush system. In FIG. 21, there are two rotating brush plates **38**, one coupled to each of the upper and lower bull wheels **62** and **63**. Rotating brush plates **38** mechanically and electrically connect to conducting section **62b** and **63b** of bull wheels **62** and **63**. A number of brushes **39** are pressed against rotating brush plate **38** by springs (not shown) and serve to transfer current from fixed brush holder assembly **40** which, in turn, is connected by jumper leads **20** to the source of current supplied to the conductor. The number, size, and properties of brushes **39** should be selected to assure acceptable current density at the point of brush contact with the rotating brush plate **38**. All components of the brush system described in this paragraph are in common application.

The number of grooves devoted to electrical contact and the diameter of the bull wheels themselves must be selected to assure acceptable current density at the conductor surface.

It is clear that use of the invention described herein should be limited to periods where there is no risk of lightning strokes. That precaution

notwithstanding, the system should be capable of surviving a transmission line short-circuit, either unanticipated or deliberate in the case of loss of tension, without damage to the conductor or to the stringing equipment. Short circuit current can be temporarily limited by inserting a reactor in series with the phase
5 being re-conducted at the feeding substations. Additionally, a bypass may be installed as shown in FIGS. 22 through 24 as a precaution against damage to the brush system due to short circuit currents.

In FIG. 22, an auxiliary reactor 48 is shown in series with the jumper lead 20, the remote end of which is identified as point R. FIGS. 23A and 23B show a
10 short circuit current bypass system consisting of a high conductivity flat bypass contact disc 49, mechanically and electrically bonded to the outside edge of the conducting portion of bull wheels, 62a and 62b in FIG. 21. In close mechanical contact with bypass contact disc 49 is a roller or metallic brush 500 which need
15 not be designed to carry current under normal conditions since the gap or surge arrester 51 will normally be equivalent to an open circuit. In the event the line is subject to a high short circuit current, the voltage drop caused by that current as it flows through the reactor 48 and the brushes 39 will cause the gap or surge
arrester 51 to flash over, thus diverting the current from the brush/brush plate
39/38 path.

20 FIG. 24 shows an electrical equivalence diagram where the combined voltage drop across the brushes 39 and auxiliary reactor 48 causes the gap or surge arrester 51 to flash over, thus diverting short circuit current from the brush assembly.

Another example embodiment of the invention is shown in FIG. 25 where an assembly consisting, in part, of a single contactor wheel **21**, separate and distinct from a bull wheel assembly, is used for transferring electrical current from or to a conductor. The assembly shown in FIG. 25 would be installed
5 between the point of departure of a conductor from a standard puller and tensioner and the point of entry or departure of the conductor to its overhead position allowing standard bull wheel configurations to be used for either pulling or tensioning. In this example embodiment the conductor **4** is caused to pass over a major portion of the contactor wheel **21** by directioning idler wheels **21 A**. The
10 contactor wheel **21** groove may be equipped with a high conductivity metallic liner. In this example however, the conductor **4** is forced into a tight metallic contact with the contactor wheel **21** by pressure wheels **21 B**, thus establishing good contact independent of the tension on the conductor itself. Arrows indicate the direction of pressure. The pressure wheels **21 B** are fixed to the same
15 framework as the contactor wheel **21** and held against it by appropriate spring mechanisms (not shown).

FIGS. 26A and 26B show still another possible embodiment in which a series of clamps **52** are mounted on the contactor wheel **21**, mechanically and electrically clamping the conductor **4** to the contactor wheel **21** but releasing prior
20 to the entry or departure point of the conductor from the contactor wheel **21**. FIG. 26B shows one possible clamp device **52** where pressure on operating arm **55** forces the upper clamp face **54**, free to pivot about its mounting frame **53** which is directly attached to the contactor wheel **21**, against the conductor **4** or, when

subject to tension, lifts the clamp face 54 off the conductor 4 and out of the way. The operating arm 55 may be caused to push or pull the clamp face 54 by any number of mechanical linkages that sense the position of rotation of the contactor wheel 21.

5 Another embodiment, shown in FIGS. 27A, 27B and 27C, uses the conductor tension as a means of assuring good contact between the conductor and a contactor wheel 21 completely separate from standard pulling and tensioning equipment and, in this example, mounted on a separate platform useable both pulling and later tensioning functions without the need for relocation of
10 equipment for the two purposes. It may also serve from that location each phase position of a three-phase transmission line.

This embodiment shows a separate contactor wheel 21 rotating about an axle that is mounted on a frame 22, that frame 22 resting on a working platform 25 that, in turn, is mounted on a second frame 23 by means of suitable insulators.
15 In this case the contactor wheel 21 is neither driven nor braked and serves only to transfer current from a clamp 24, the function of which is explained later, through a jumper lead 20, to a brush assembly 17 to the contactor wheel 21 and by way of that wheel 21 to whatever conductor is wrapped around it.

FIGS. 28A and 28B show the contactor wheel 21 assembly of FIGS. 27A,
20 27B, and 27C in somewhat more detail and with the same current transfer scheme cited previously. The contactor wheel 21 with a soft metal surface or liner should have a sufficient length of conductor-to-wheel contact area to transfer current between the two members without generating excess heat. In FIGS. 28A and

28B, a conductive brush contact plate **38**, mounted on and rotating with the contacting wheel **21** and well connected to the surface against which the conductor turns **4** are pressed. A series of brushes **39** are caused to press against the brush contact plate **38** by conventional brush support assemblies, the brushes
5 **39** being supported by and electrically fed by a stationary assembly **40** which, in turn, is connected to either the incoming or outgoing line conductor as shown in previous figures.

FIG. 29 shows the transfer device of FIGS. 28A, 28B, and 28C located in mid-span with the old conductor **8** drawn down to the clamp **24** preparatory to the
10 stringing operation. FIG. 30 shows a conducting lead cable **11** attached to the old conductor **8**, fed around the contact wheel **21**, and to the puller. Pulling up slack on the old conductor **8** to sever it and achieve the configuration shown in FIG. 30 can be achieved by methods outlined previously. It should be noted that
15 longitudinal tension on the transfer device will be approximately balanced throughout this transfer. The puller, which may now be comprised of standard equipment and prior art, need only be adapted for operation at line potential as discussed later.

FIG. 31 shows the use of the same transfer device, at the same location, in conjunction with a tensioning device for the pulling section immediately to the
20 left of the one completed while the device was used in conjunction with pulling equipment.

The previous figures presume a single three-phase transmission line with one conductor on each phase. Inasmuch as the techniques described by this

invention build on methods well developed for stringing new conductors (without voltage) on new towers, there is no reason that the invention disclosed herein may not be embodied into projects and equipment for simultaneously stringing multiple conductors on each phase.

5 **Insulation of Equipment from Ground**

There are many ways in which the principles and equipment disclosed in this invention can be implemented. FIGS. 32A and 32B, for example, show a means way by which a tensioner or a puller might be mounted on a dedicated vehicle **26**. Height could be reduced by recessing the bottom of the insulators into wells inherent in the truck bed design. The engines or brake assemblies could be
10 incorporated onto the insulated platform or placed on an un-insulated trailer **28** and **29**, mechanically coupled to the tensioner or puller by means of an insulated shaft **27**.

FIG. 33 shows one simple manner in which tensioning or pulling
15 equipment can be applied, i.e., by erecting a transportable platform **30** and supporting it by means of a system of insulators **32**, gaining truck access by a ramp **31** that is removed once the equipment is in place.

FIGS. 34A and 34B show a collapsible platform **30** with a ground
platform **34** in which the support insulators **32** are attached to pivoted support
20 assemblies **33** which allow the platform to go from its collapsed state, as shown in FIG. 34A, to its erected state, as shown in FIG. 34B, for use.

Recognizing that personnel access may be required while the platform and equipment are at line potential, FIGS. 35A and 35B show an insulated arm **35**, on

the end of which is a personnel bucket 37. The insulated arm 35 is attached to swiveling platform extension 36. The arm 35 is capable of being rotated outward and downward to allow safe entrance to or egress from the high voltage platform.

Power lines of vertical configuration

5 The figures previously shown presume a transmission line in which the conductors are presumed to side-by-side in a horizontal configuration. There is no reason the invention cannot be used on transmission towers on which two transmission circuits are arrayed vertically as illustrated in FIG. 36, which shows a double circuit tower 41. In this case it will be necessary to both feed and pull
10 the new conductor from a point to the side of rather than below the conductor being replaced.

 The laterally oriented tensioning and pulling may, as illustrated in FIG. 36, require use of an auxiliary block 44 suspended either from an insulated auxiliary support structure or "gin pole" 43, or from a vehicle-mounted insulated structure
15 (not shown). The fed or pulled new conductor 4 would then pass from the above-described tensioner or puller 45 through the auxiliary block 44 to the previously described stringing block 9 longitudinally onto the line.

 Pulling or tensioning in the direction shown in FIG. 36 will cause a high overturning moment on the tower and may thus require another auxiliary support
20 structure or "gin pole" 43 to support a guy wire 42 which in turn is affixed to a temporary anchor 12 in the ground.

Description of the Preferred Short Interruption Embodiment

The procedures and equipment cited above for uninterrupted embodiment can be achieved with conventional equipment operating at ground potential if, while the line remains energized prior art hot-line methods

5 are used to:

- a. Replace permanent clamps 7 with stringing blocks 14 on all towers in the restringing line section, i.e. from tower 101 to tower 200 inclusively.
- b. The procedures illustrated in FIGS. 5 through 6 are used at
10 both ends of the pulling section except that an insulator assembly 15 is used to separate the puller or tensioner from the live conductor to which it is attached. FIG. 37 shows such a configuration for the pulling end at tower 200.

Once the configuration shown in FIG. 37 is achieved at both towers 100 and
15 200, the line may be de-energized, the insulator assembly 15 mechanically bypassed and removed, and conventional prior art pulling operation undertaken.

Upon completion the tie-off procedures illustrated in FIGS 11-15 may be used, after which the line may be re-energized. Following
20 energization, stringing blocks 14 can be replaced by permanent clamps 13, and preparations for the next section undertaken. Thus the transmission line is taken out of service during a period of light system loading for several hours while the old conductor is used to pull in the new conductor in the manner

described in the no-interruption case above except with both puller and tensioner at ground potential and with no provisions for transfer of current from one conductor to another.

The foregoing has the advantage of using conventional, prior art, equipment but the disadvantage of (a) requiring line interruption during the actual pulling operation, (b) limiting the length of line which can be pulled per day with a given equipment set-up and (c) creating a risk that the transmission line will be unavailable for service if delays or difficulties are encountered in the pulling in of the new conductor.

10 Safety Precautions

The safety of personnel is a primary concern in any live line maintenance or construction work. The following features are therefore included in the above invention:

1. As shown in FIG. 36, elevated platforms and their immediate surrounding work area may be enclosed by a high, well grounded fence 46, and the access gate may be interlocked to prevent ingress or egress while pulling is in progress.
2. As further shown in FIG. 36, a well grounded ground mat 47 may extend over the entire area enclosed within the fence cited above to prevent danger from step potential in the event of a short circuit.
3. A means of safely entering and leaving the insulated platform while the major equipment is at line potential may be provided.

4. Low tension, high tension, and rapid tension change sensors capable of actuating high speed grounding switches at both tensioning and pulling ends of the section being strung may be provided.
- 5 There is also a risk inherent in the prospect that, during stringing, a sheave in a particular stringing block will jam, e.g. because of a sheave fracture or a stuck clamp or coupler, thus transferring the full stringing tension, intended to draw a conductor into place, to the tower on which the jam occurs. A jam of that kind can result in damage to the cross arm or even cause the tower itself to topple. This is especially important with live-line stringing, both from the standpoint of a safety and the outage cost of a line which, having justified the extra cost of live-line stringing, is obviously critical to the system.

A system to prevent such damage is illustrated in FIG. 38. FIG. 38A illustrates a special jam-sensing system consisting of a stringing block 56 preparing to rotate and to transport the new conductor 4 into position. FIG. 38B shows that once the pull has begun, some change in the suspension angle, α , of the insulator/block assembly will result from the pull. Reasonable and safe limits to α can be predicted. In FIG. 38B, the sheave of the stringing block 56 is rotating normally and the conductor 4 is moving.

20 Should the sheave jam either due to a fracture, sticking, or a stuck coupler, rotation of the sheave will stop, thus causing the suspension angle to increase to β as shown in FIG. 38C. This dangerous condition can be detected either by (a) increase of the suspension angle by some pre-calculated amount or (b) increase in

the suspension angle of any amount and a failure of the jam-sensing sheave 56 to rotate. Both suspension angle and sheave rotation can be measured by a variety of existing prior art sensor systems.

Sensors to make such measurements, plus a microwave transmitter to send
5 them to both pulling and tensioning positions, are shown schematically in FIG. 38 as 57. Since each pulling operation takes relatively little time, the on-board jam sensor can be battery powered. The signal from each block in a stringing section may, within certain severity limits, be cause for alarms and, within greater limits, automatic cessation of the pull.

10 The jam-sensing sheave system 56 can easily include measurement of sheave bearing temperature. A high temperature and/or a high rate of rise of temperature may give an early warning that a jam may be pending. The system may also be made to read conductor speed relative to the stringing block, adding to the logic of jam detection. All of the above sensing systems, taken individually,
15 constitute prior art. Their collective use to detect and transmit a sheave jam or impending jam constitutes a part of this invention.

A variety of modifications to the embodiments described herein will be apparent to those skilled in the art from the disclosure provided herein. Thus, the invention may be embodied in other specific forms without departing from the
20 spirit or essential attributes thereof.

I claim:

1. A method for substituting an existing high-voltage electrical power conductor with a replacement high-voltage electrical power conductor, comprising:
connecting the replacement high-voltage electrical power conductor to the existing high-voltage electrical power conductor; and
5 pulling the existing high-voltage electrical power conductor.
2. The method of claim 1 where at least a portion of the existing high-voltage electrical power conductor remains energized.
3. The method of claim 1 where at least a portion of the replacement high-voltage electrical power conductor is energized.
- 10 4. The method of claim 1 further comprising establishing a continuous flow of electric current through at least a portion of the existing high-voltage electrical power conductor and through at least a portion of the replacement high-voltage electrical power conductor.
5. The method of claim 1 wherein connecting the replacement high-voltage electrical power conductor to the existing high-voltage electrical power conductor
15 includes:
connecting the existing high-voltage electrical power conductor to a fixed point through an insulator at a first location;
connecting the replacement high-voltage electrical power conductor to the
20 existing high-voltage electrical power conductor at a second location;
connecting a jumper to the existing high-voltage electrical power conductor at a third location;

providing a path for an electric current between the third location and the second location; and

cutting the existing high-voltage electrical power conductor at a point between the first location and the second location.

5 6. A system for substituting an existing high-voltage electrical power conductor with a replacement high-voltage electrical power conductor, comprising:

a device for mechanically and electrically connecting the replacement high-voltage electrical power conductor to the existing high-voltage electrical power conductor;

10 a first apparatus for supplying the replacement high-voltage electrical power conductor, where the first apparatus includes a first mechanism for conducting electric current;

a first jumper for electrically connecting the first apparatus to the existing high-voltage electrical power conductor;

15 a second apparatus for pulling the existing high-voltage electrical power conductor, where the second apparatus includes a second mechanism for conducting electric current; and

a second jumper for electrically connecting the second apparatus to the existing high-voltage electrical power conductor.

20 7. The system of claim 6 where the first apparatus and the second apparatus each include at least one rotating drum and at least one brush, where the at least one rotating drum and the at least one brush are adapted to conduct electric current.

8. The system of claim 7 where the at least one rotating drum includes at least a first groove adapted for maintaining tension on the high-voltage electrical power conductor and at least a second groove adapted for conducting electric current to the high-voltage electrical power conductor.
- 5 9. The system of claim 7 where a first portion of the at least one rotating drum has a first diameter and a second portion of the at least one rotating drum has a second diameter that is larger than the first diameter.
10. The system of claim 9 where the second portion of the at least one rotating drum is adapted to cause a wiping action.
- 10 11. A system for substituting an existing high-voltage electrical power conductor with a replacement high-voltage electrical power conductor, comprising:
means for connecting the replacement high-voltage electrical power conductor to the existing high-voltage electrical power conductor;
means for supplying the replacement high-voltage electrical power
15 conductor; and
means for pulling the replacement high-voltage electrical power conductor.
12. The system of claim 13, further comprising means for establishing a continuous flow of electric current through at least a portion of the existing high-voltage electrical power conductor and through at least a portion of the replacement
20 high-voltage electrical power conductor.

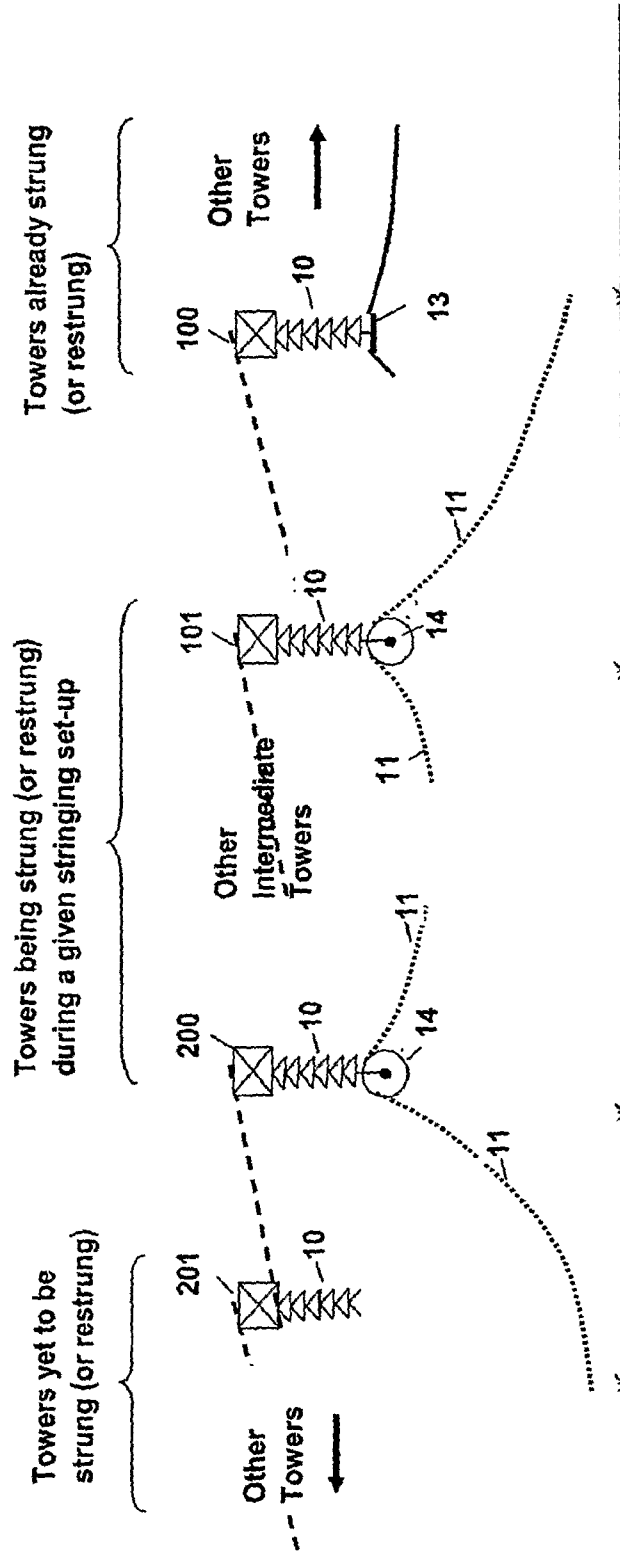

FIG. 1 Prior Art

2/35

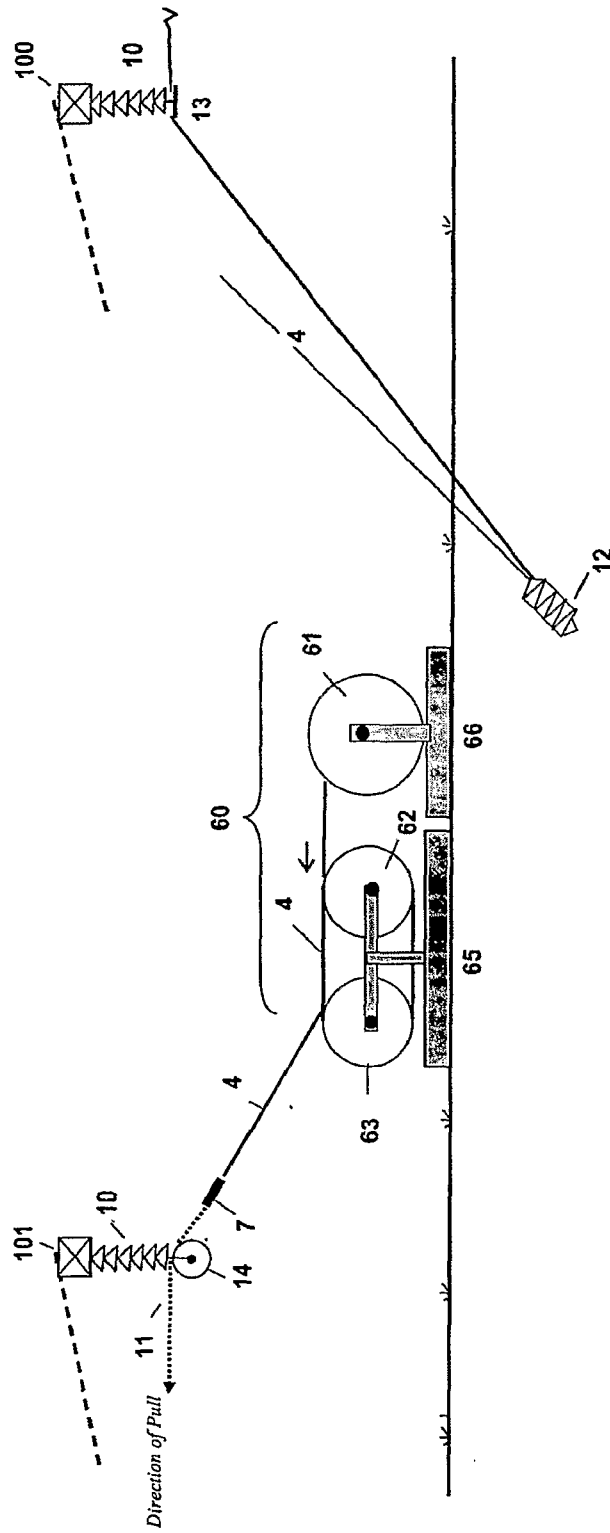

FIG. 2 Prior Art

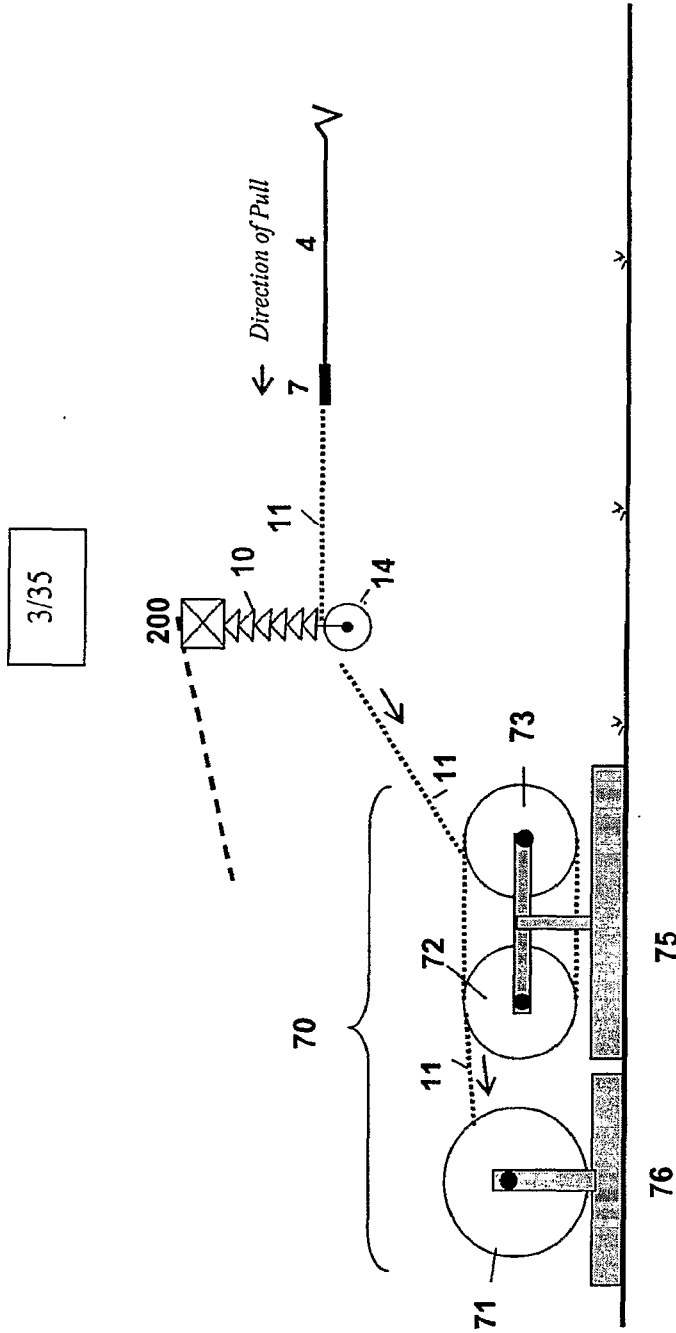

FIG. 3 Prior Art

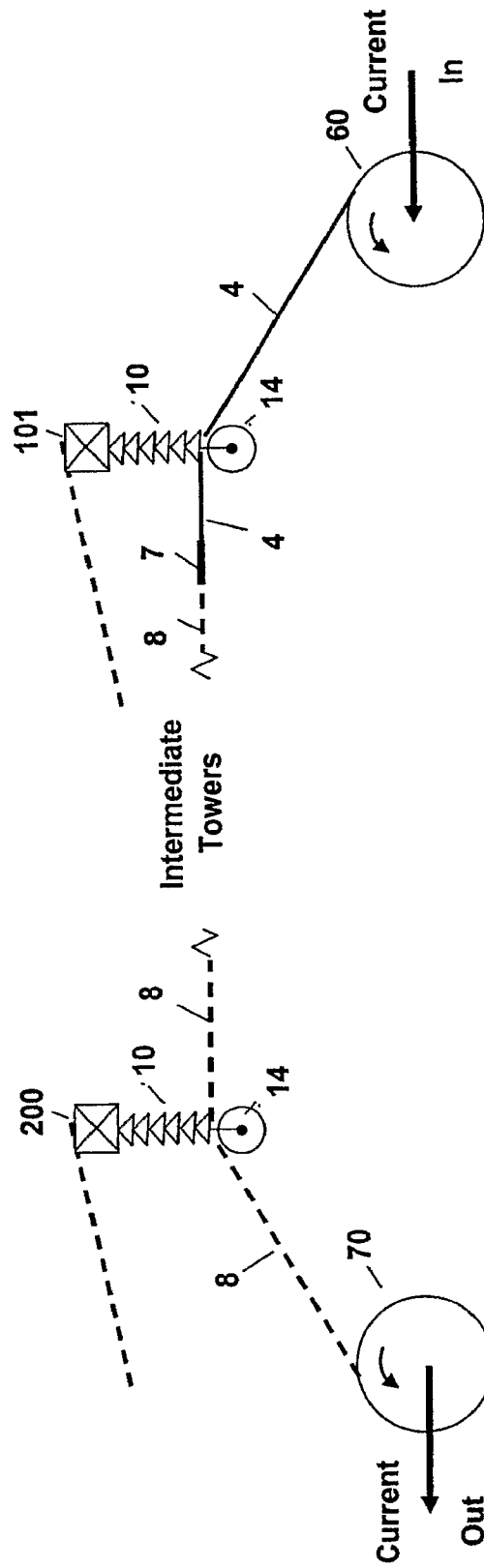

FIG. 4

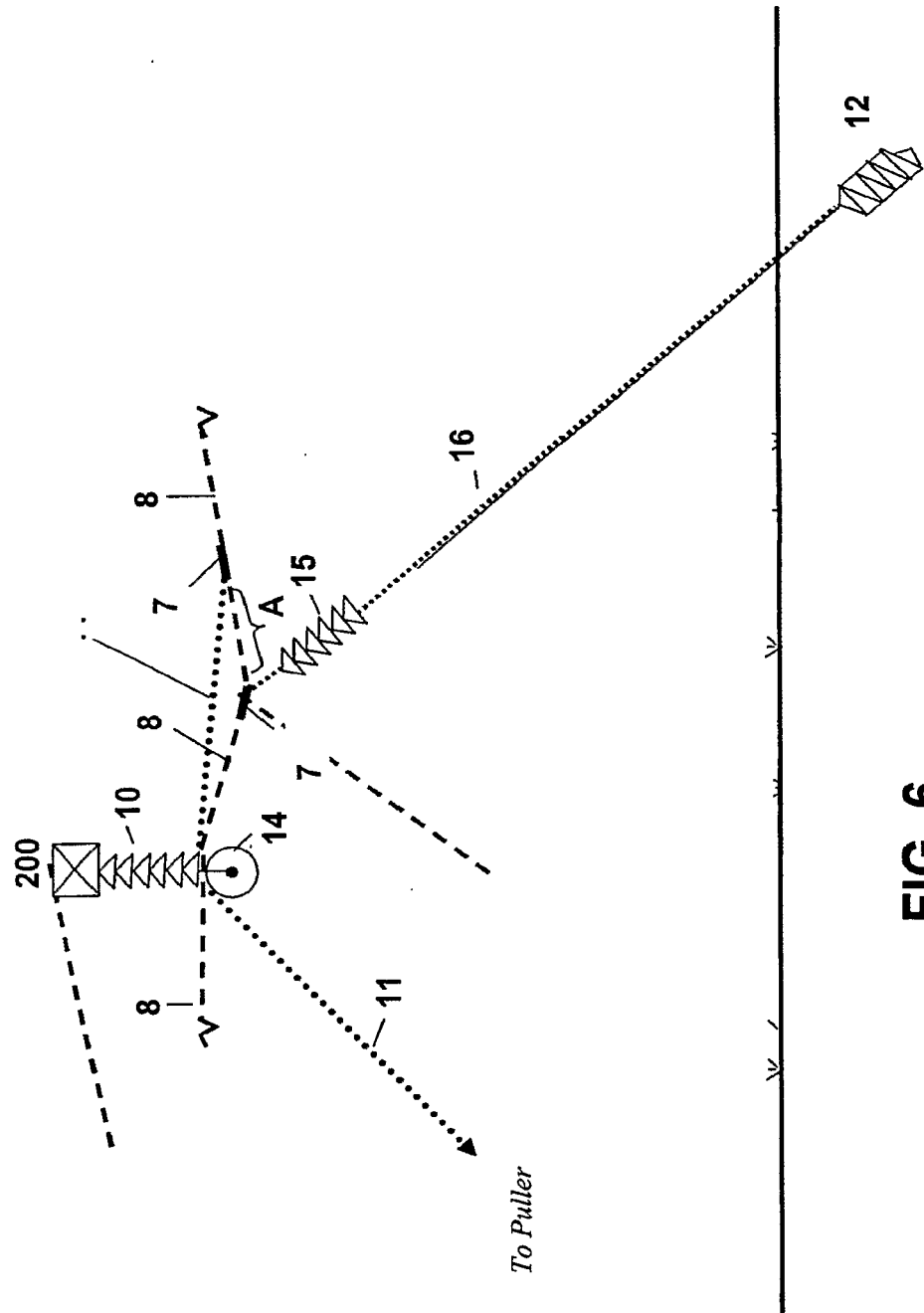

FIG. 6

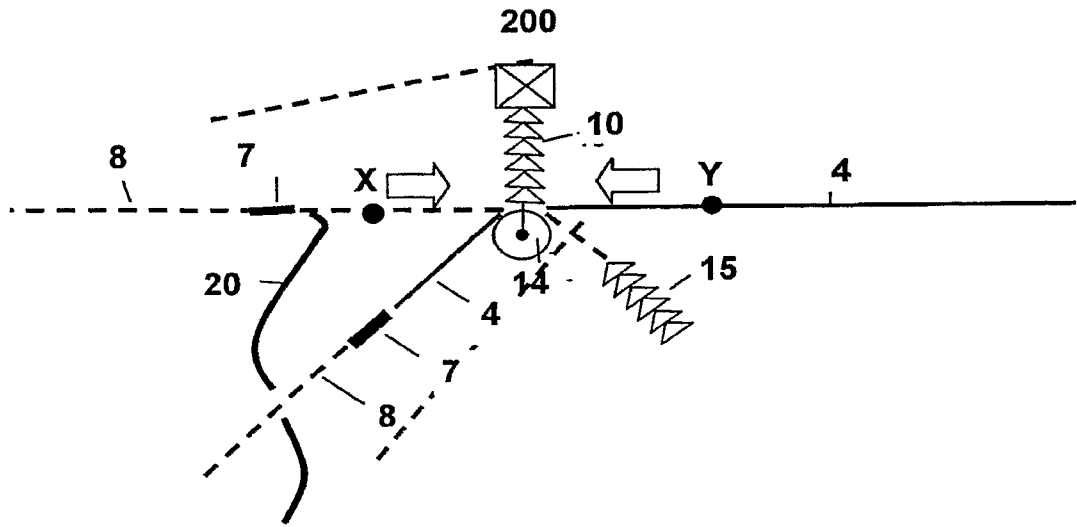

FIG. 11

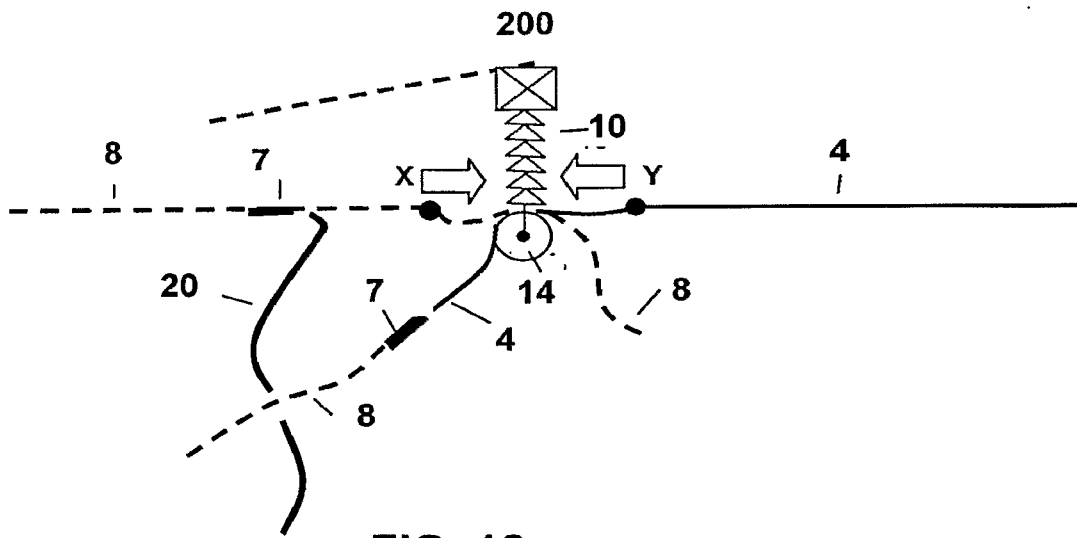

FIG. 12

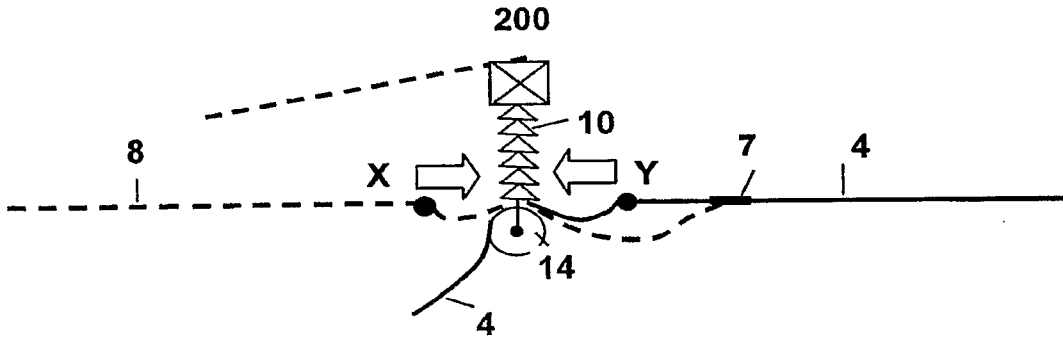

FIG. 13

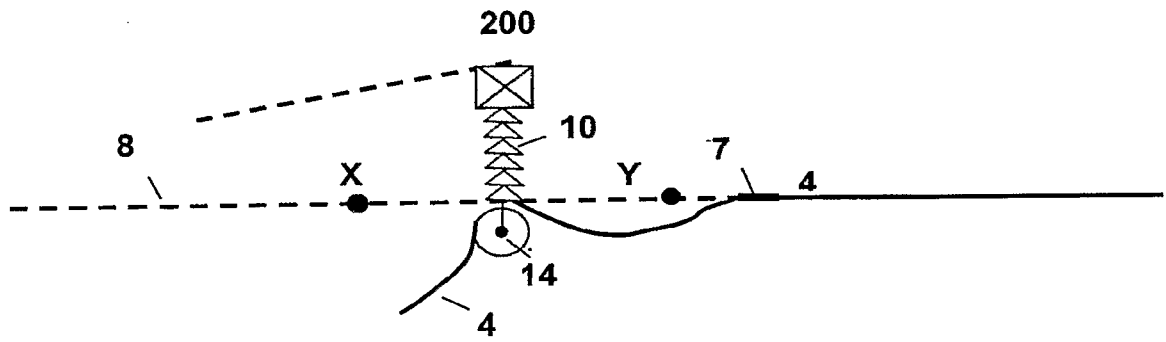

FIG. 14

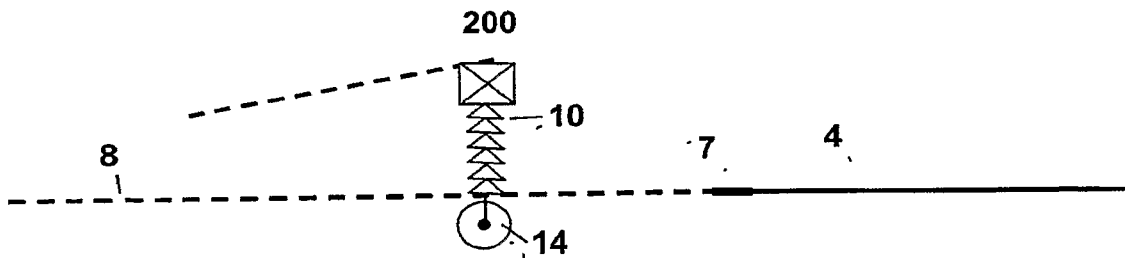

FIG. 15

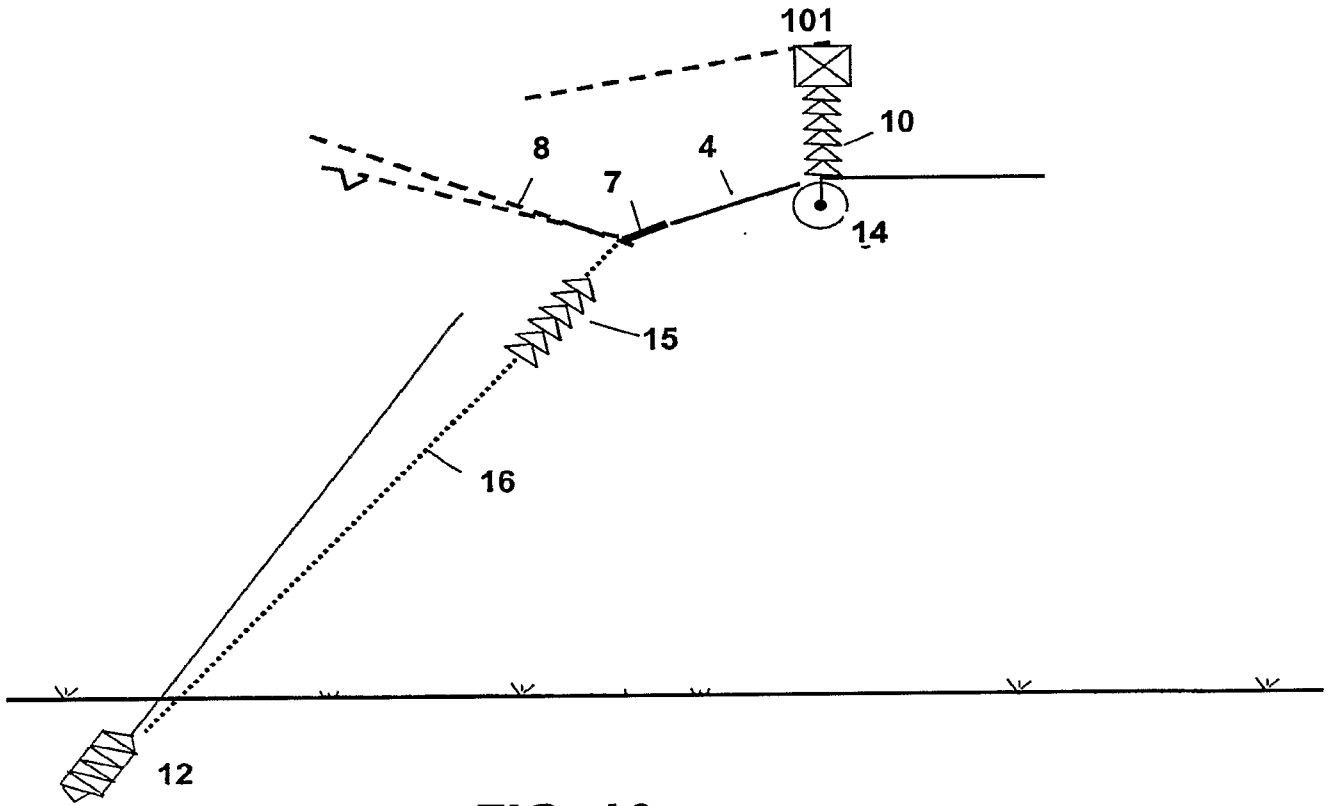

FIG. 16

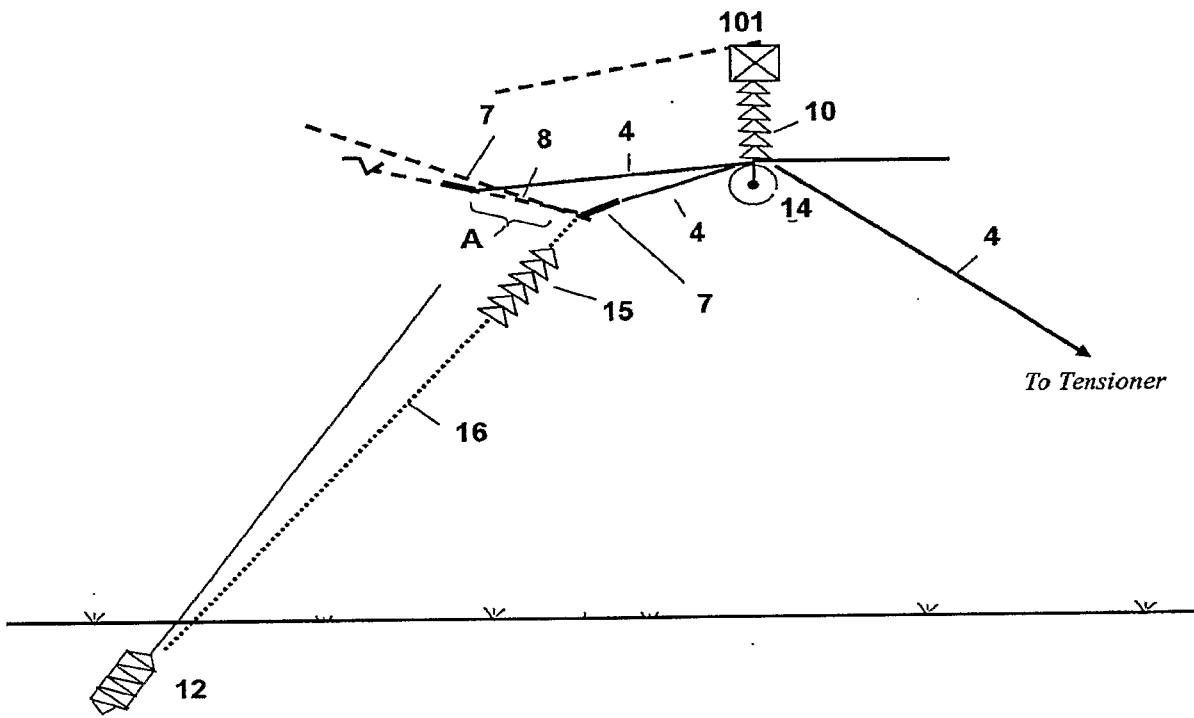

FIG. 17

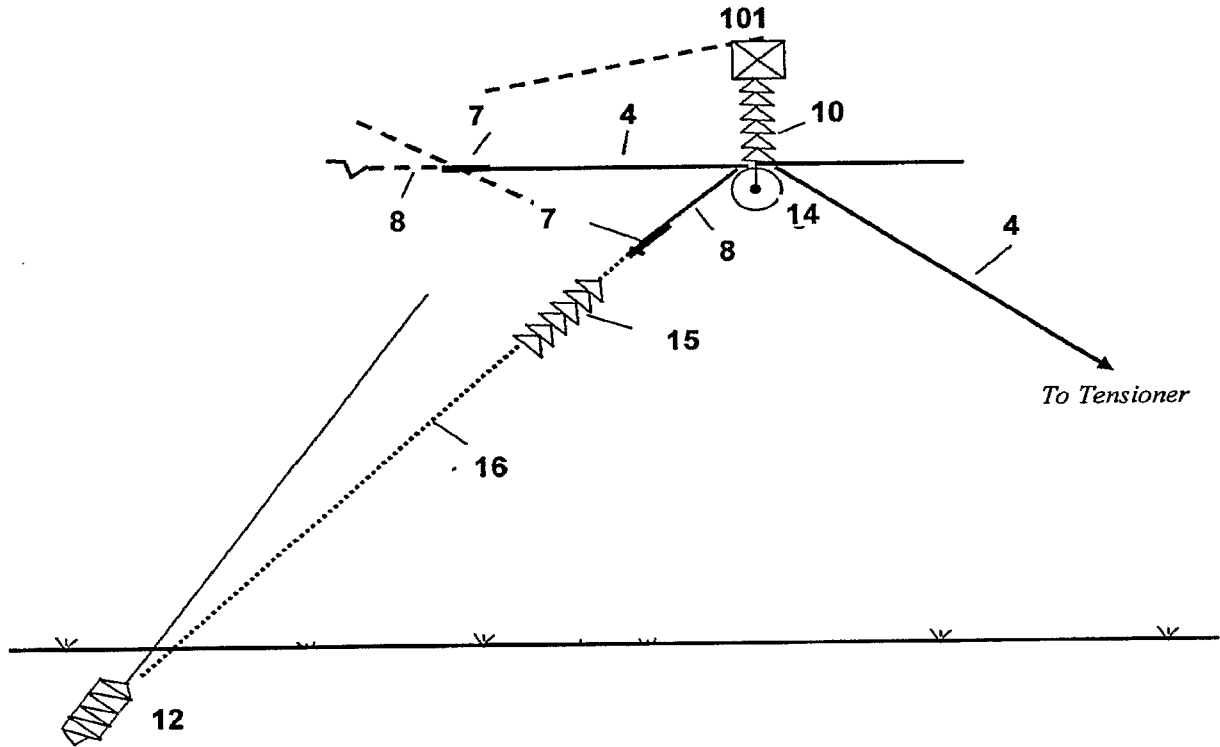

FIG. 18

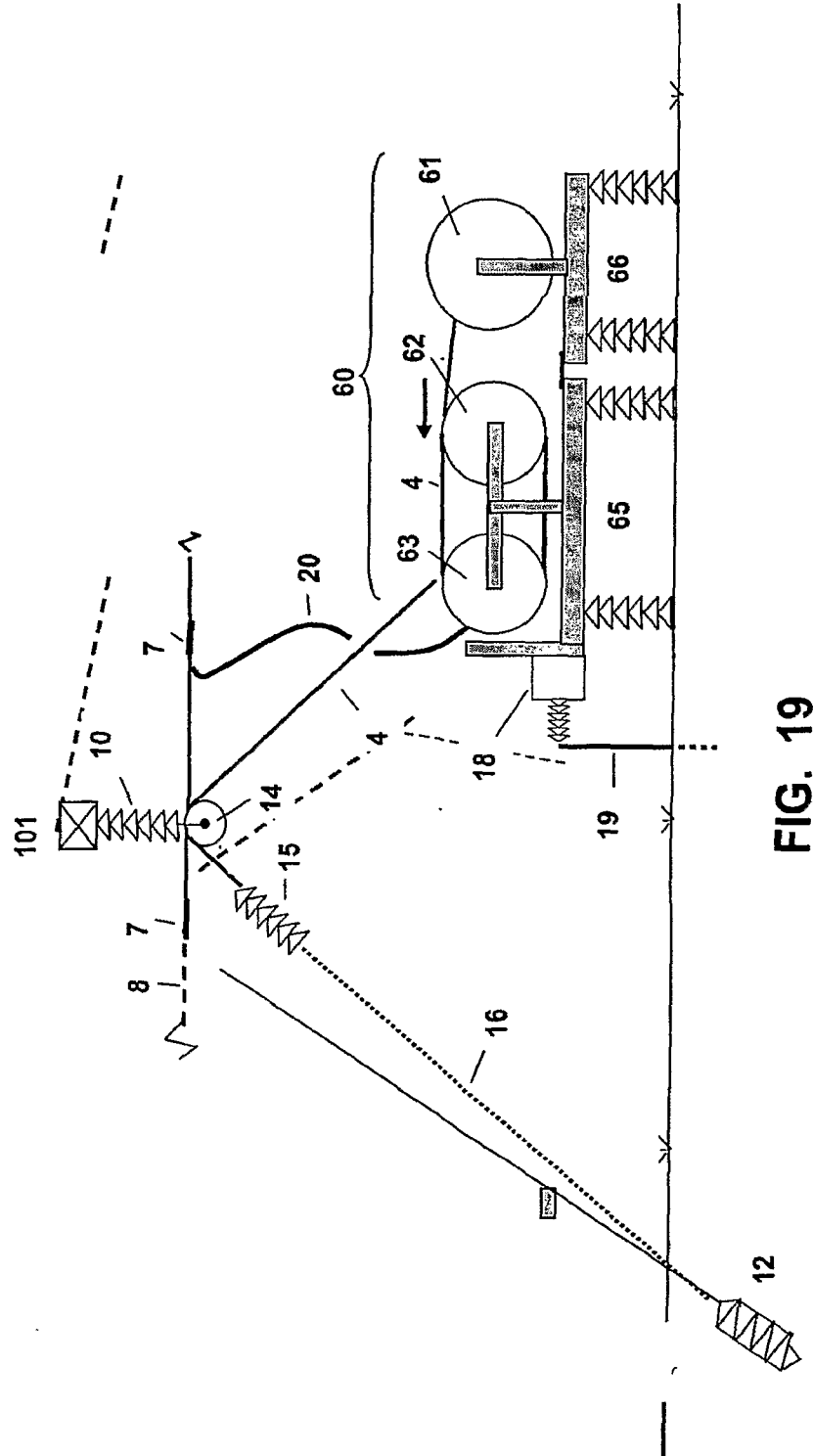

FIG. 19

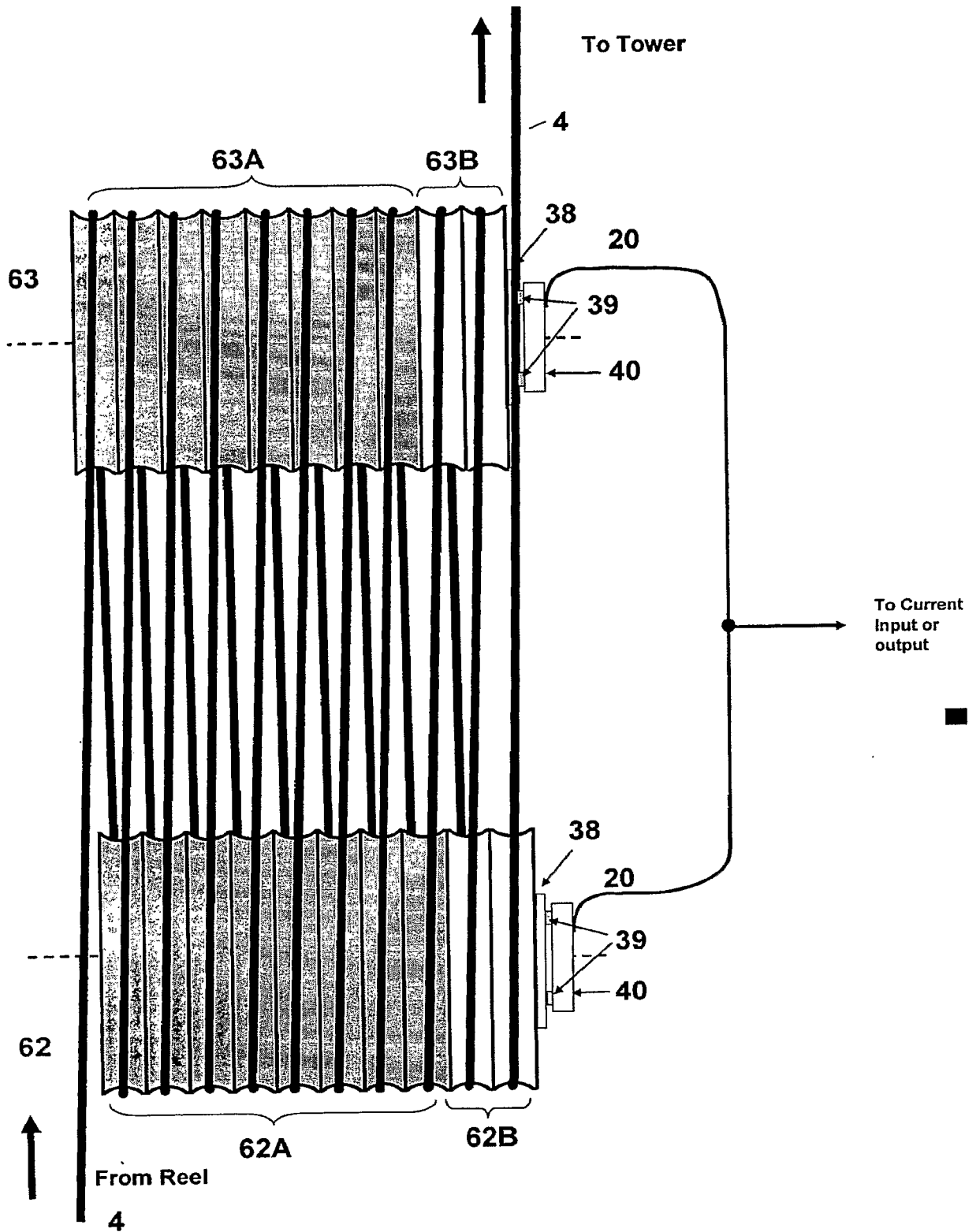

FIG. 21

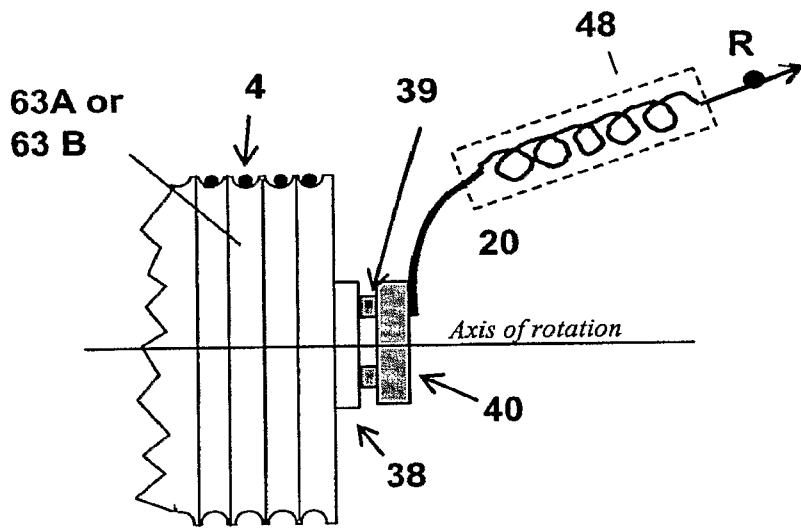

FIG. 22

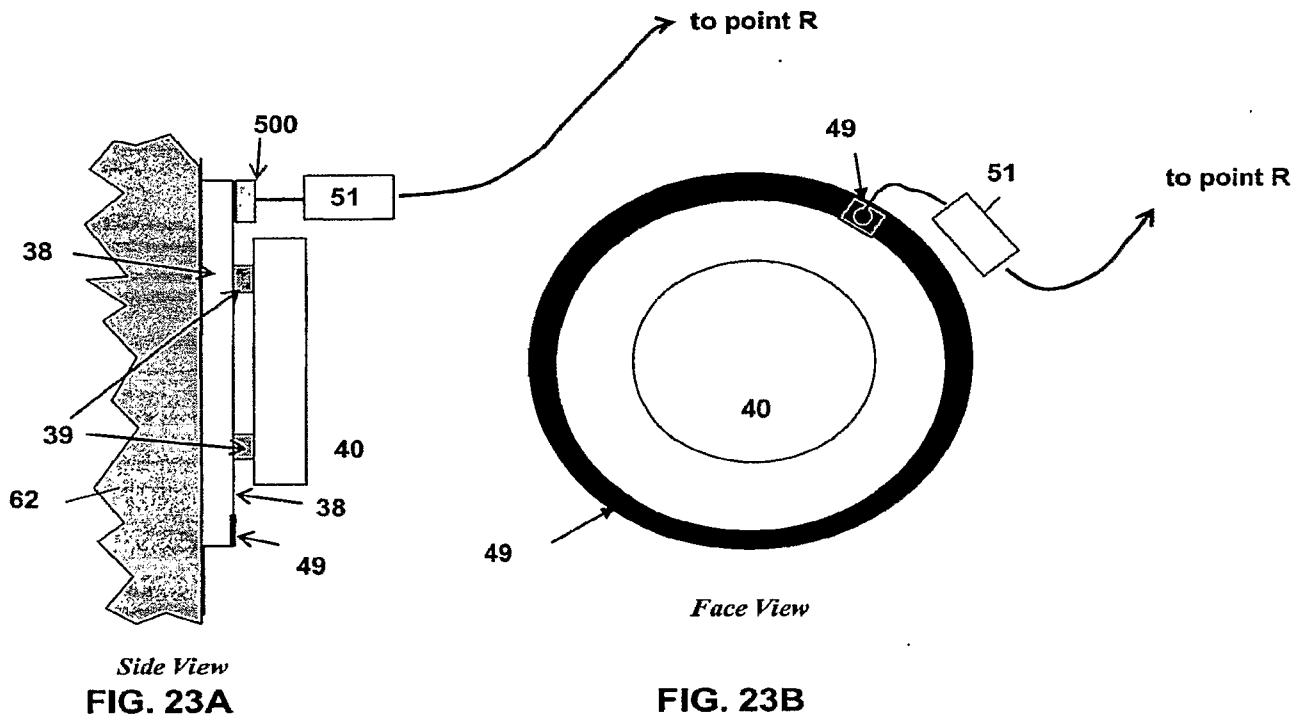

FIG 23

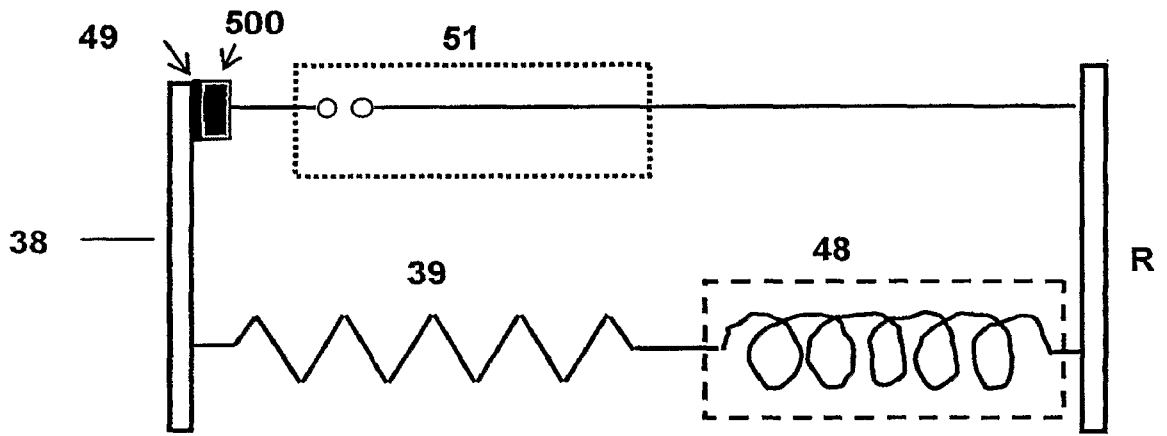

FIG. 24

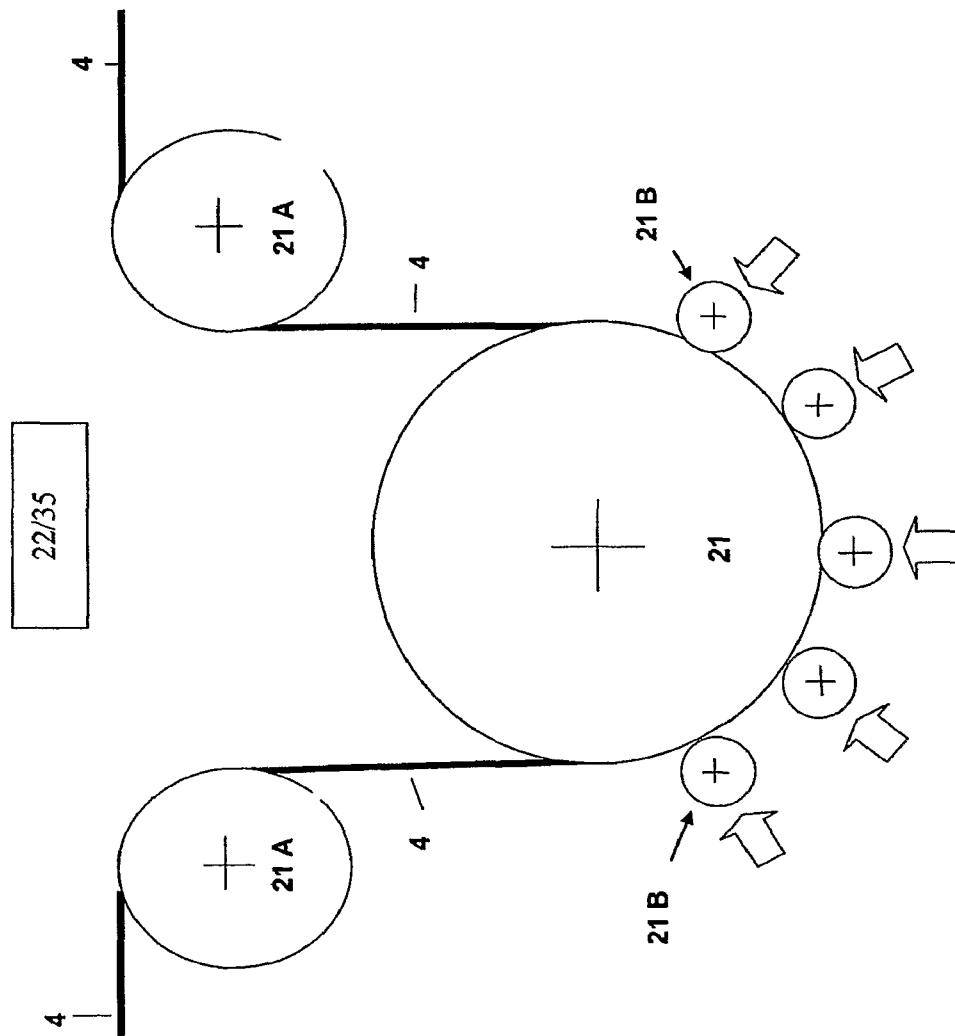

FIG . 25

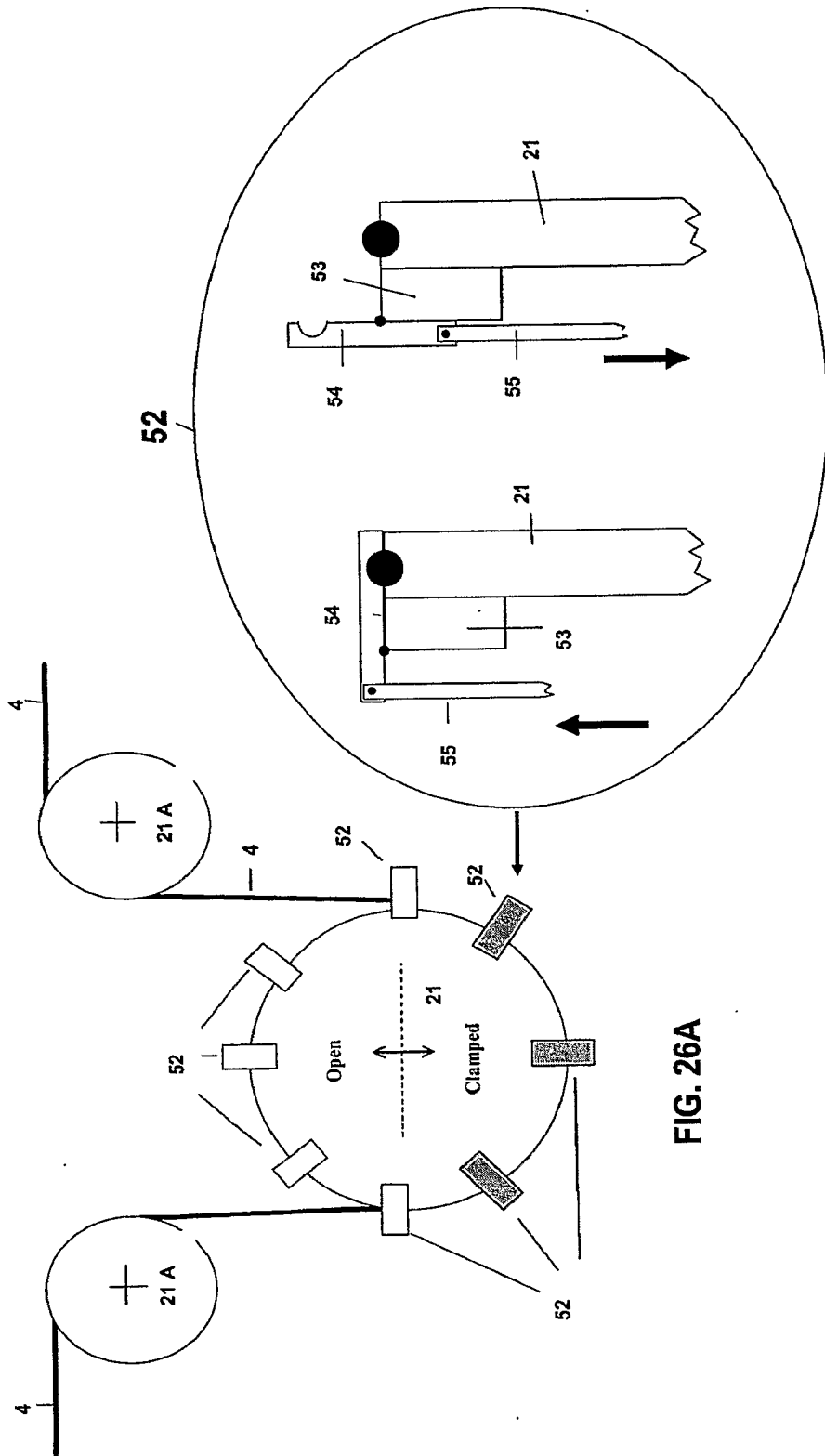

FIG. 26A

FIG. 26

FIG. 26B

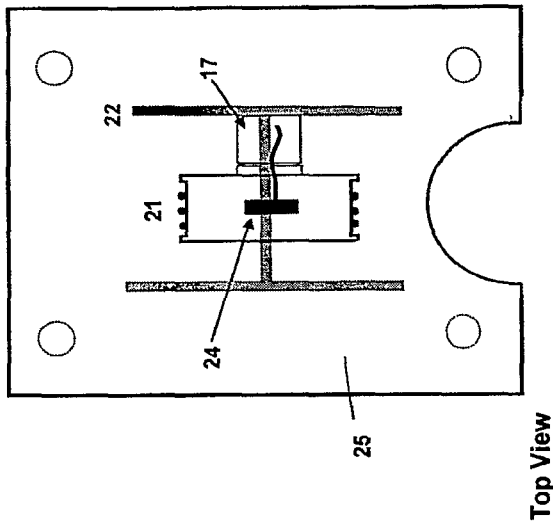

FIG. 27A

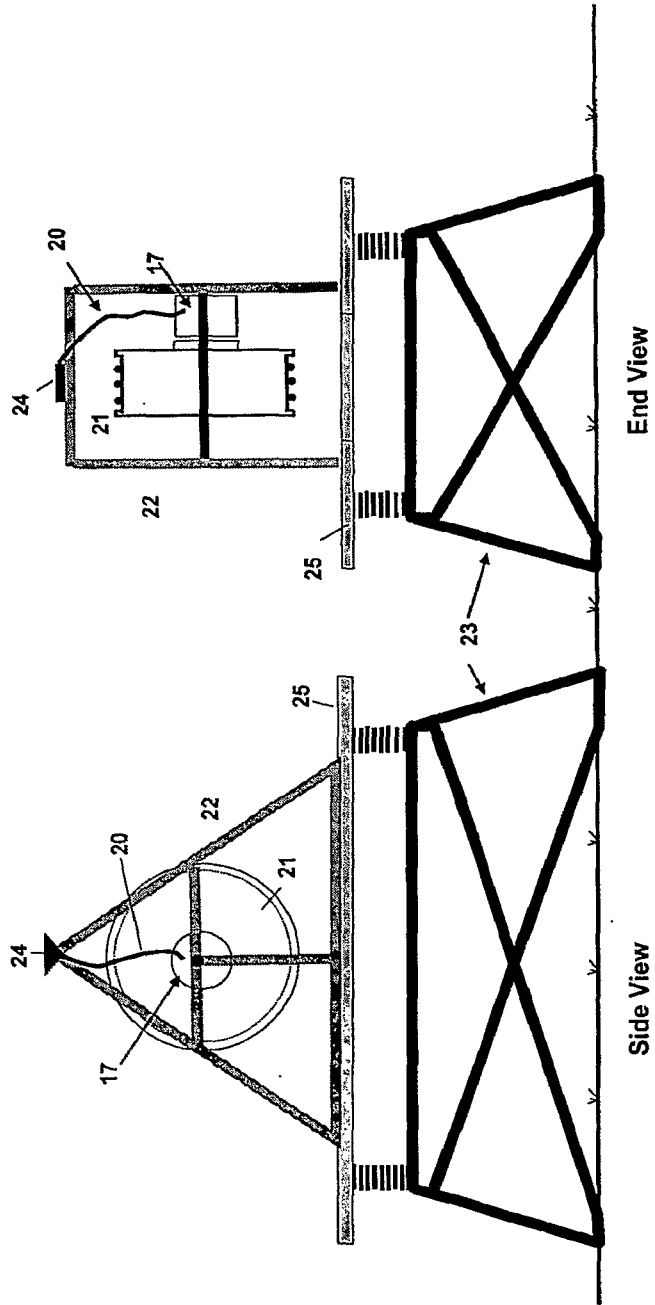

FIG. 27B

FIG. 27C

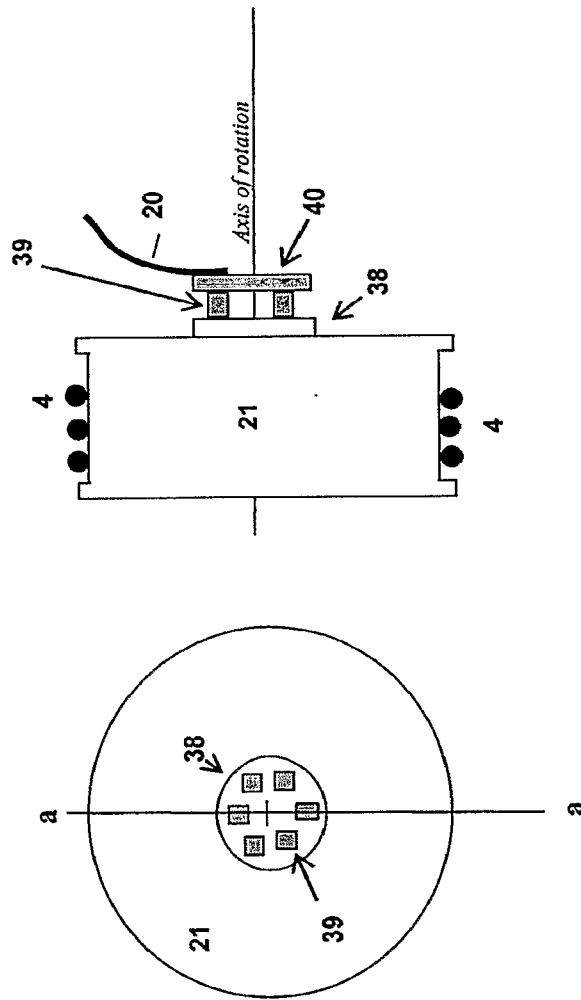

FIG. 28B

FIG. 28A

FIG. 28

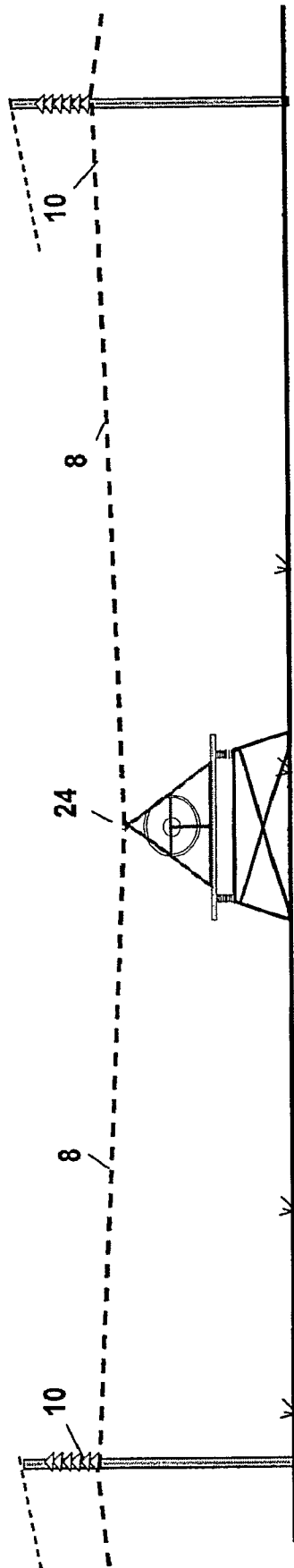

FIG. 29

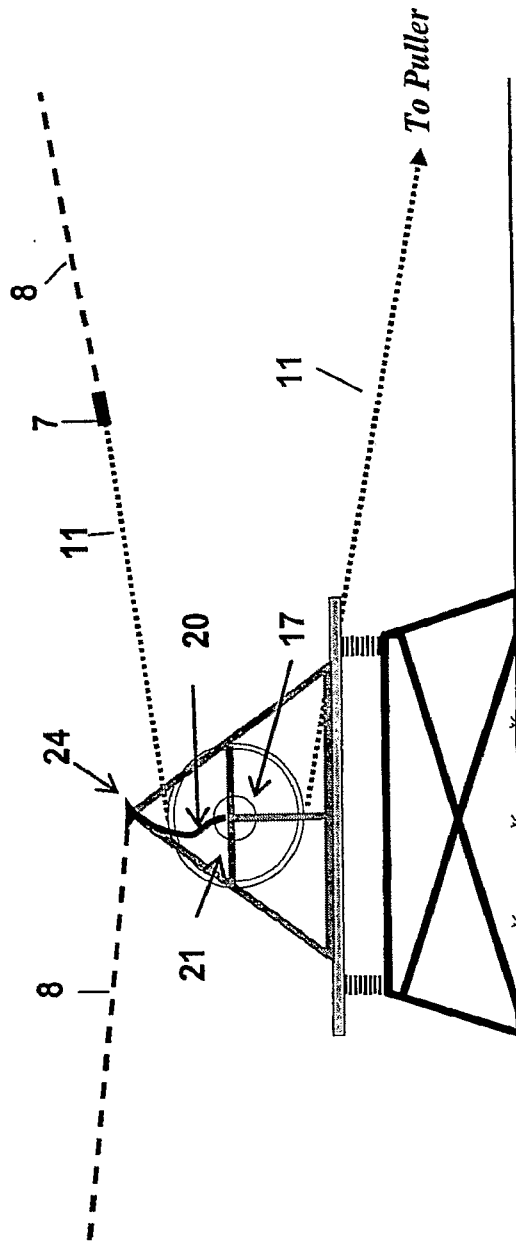

FIG. 30

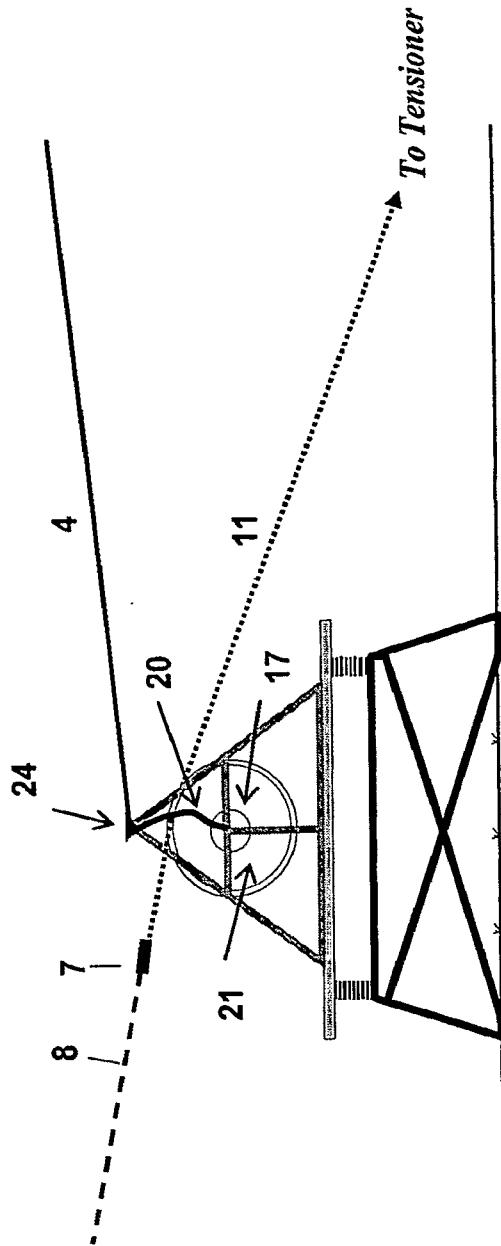

FIG. 31

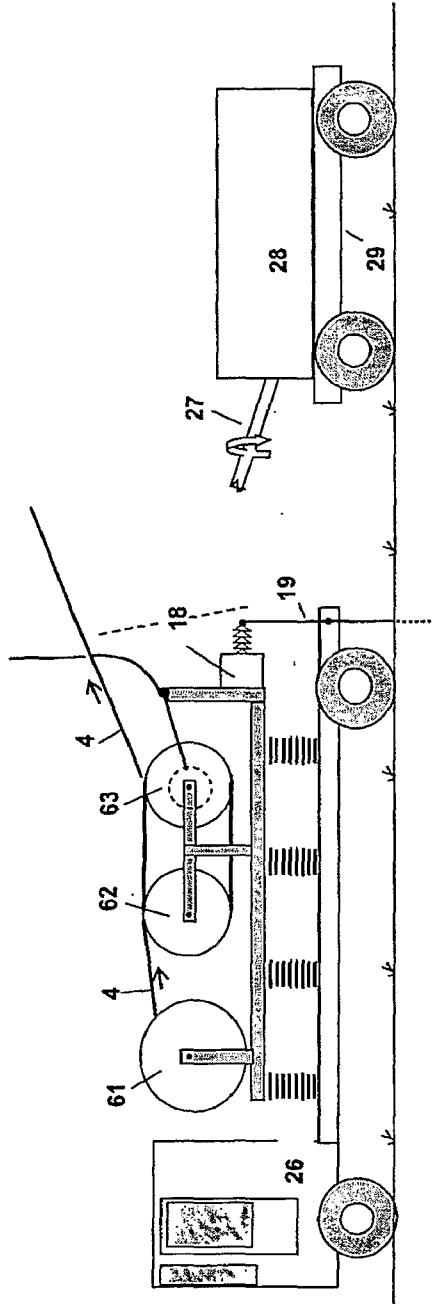

FIG. 32A

FIG. 32B

FIG. 32

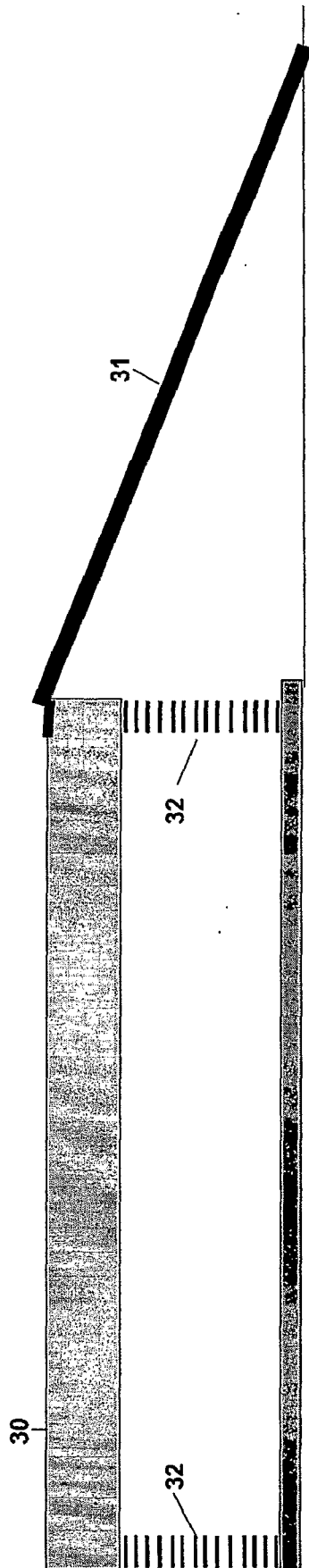

FIG. 33

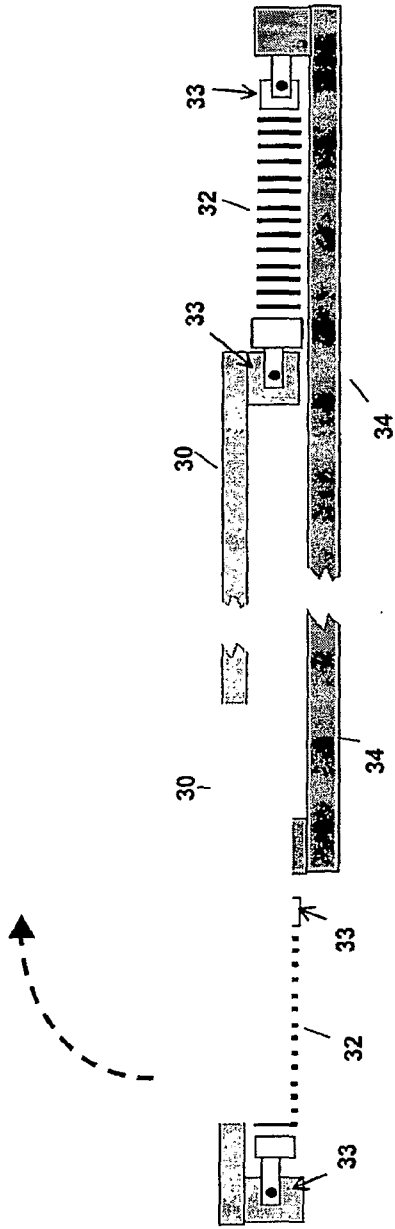

FIG. 34A

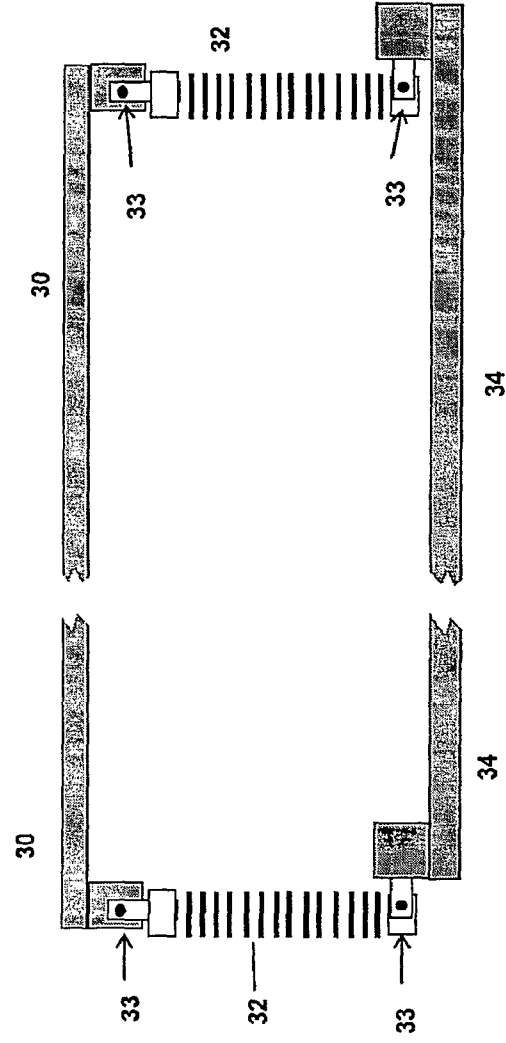

FIG. 34B

FIG. 34

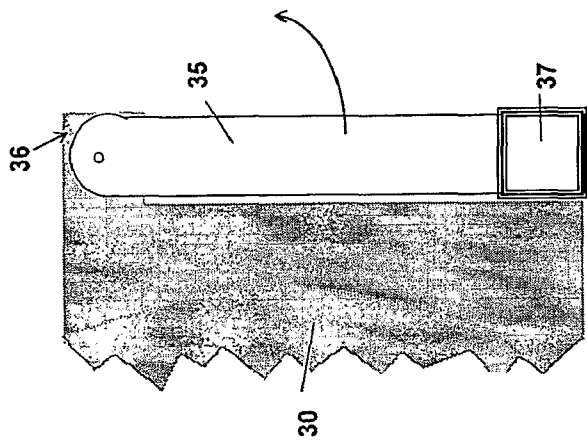

FIG. 35A

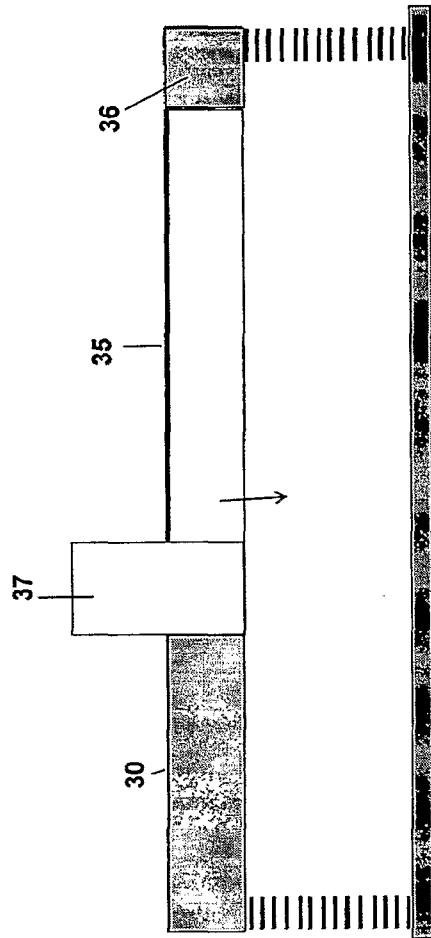

FIG. 35B

FIG. 35

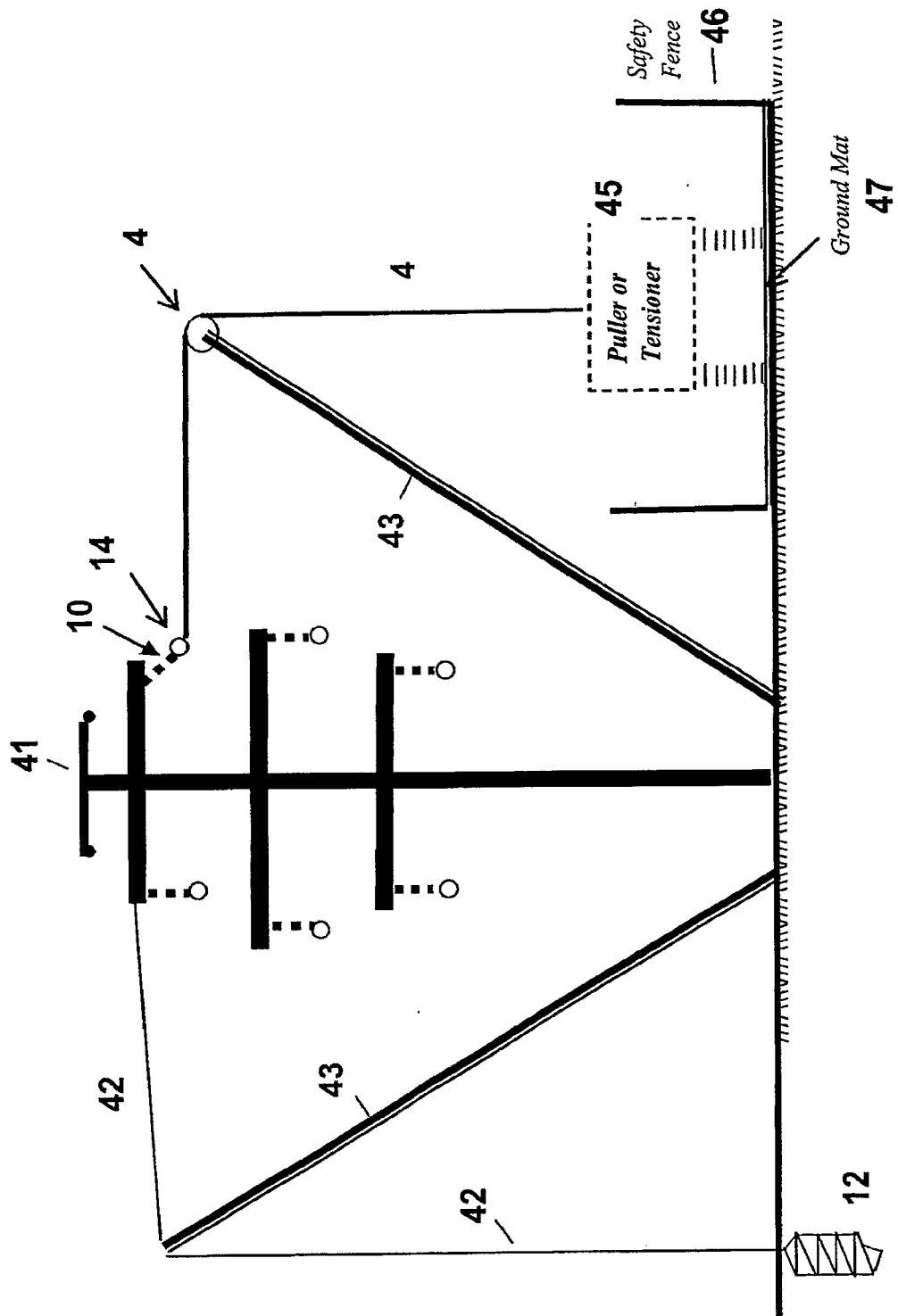

Fig. 36

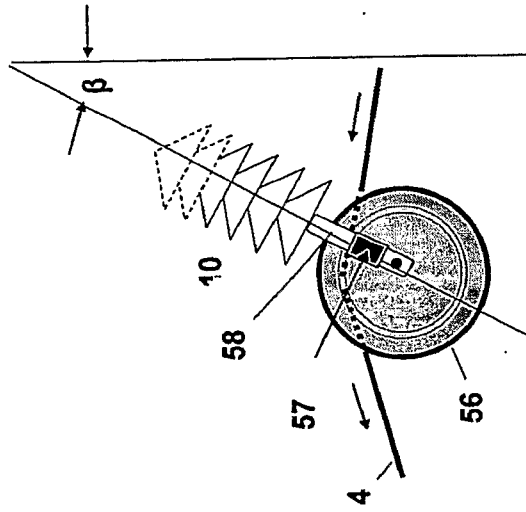

FIG. 38C

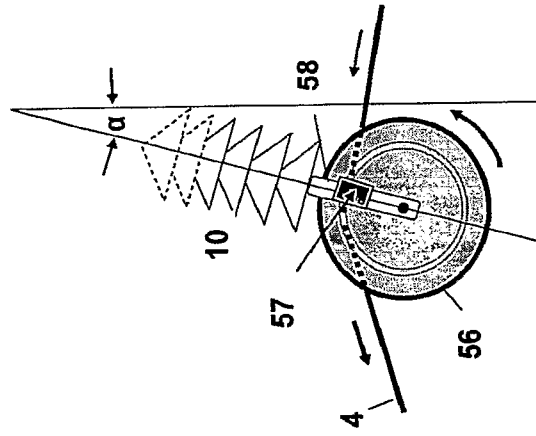

FIG. 38B

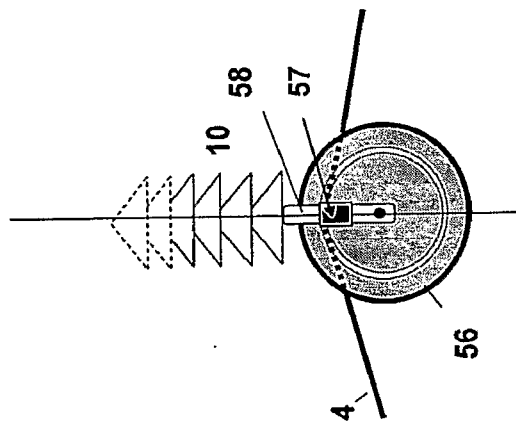

FIG. 38A

FIG. 38

INTERNATIONAL SEARCH REPORT

International application No.

PCT/US2007/000607

A. CLASSIFICATION OF SUBJECT MATTER

Int. Cl. **H02G 1/04** (2006.01) **H02G 7/00** (2006.01)

US Cl. 174/040R

According to International Patent Classification (IPC) or to both national classification and IPC

B. FIELDS SEARCHED

Minimum documentation searched (classification system followed by classification symbols)

Documentation searched other than minimum documentation to the extent that such documents are included in the fields searched

Electronic data base consulted during the international search (name of data base and, where practicable, search terms used)

DWPI, ESP@CE, USPTO, INTERNET: Keywords (high, voltage, power, line, replacement, live) and similar terms.

C. DOCUMENTS CONSIDERED TO BE RELEVANT

Category*	Citation of document, with indication, where appropriate, of the relevant passages	Relevant to claim No.
X	WO 2004/079877 A1 (CERTAS PLC) 16 September 2004 See Page 16 line 25 – page 17 line 5 and claims	1, 11
A	US 2005/0133244 A1 (DEVINE et al.) 23 June 2005	1 – 12
A	WO 2003/005516 A1 (DAEWON ELECTRIC COMPANY LIMITED) 16 January 2003	1 – 12
A	BRAGA A. E., <i>Conductor Cable Replacement on an Energized Transmission Line, Transmission and Distribution Construction, Operation and Live-Line Maintenance</i> Proceedings 2000 IEEE ESMO – 2000 IEEE 9 th International Conference. Montreal, Que. 8 – 12 October 2000, Pages 392 – 396.	1 – 12

 Further documents are listed in the continuation of Box C See patent family annex

* Special categories of cited documents:

"A" document defining the general state of the art which is not considered to be of particular relevance

"T" later document published after the international filing date or priority date and not in conflict with the application but cited to understand the principle or theory underlying the invention

"E" earlier application or patent but published on or after the international filing date

"X" document of particular relevance; the claimed invention cannot be considered novel or cannot be considered to involve an inventive step when the document is taken alone

"L" document which may throw doubts on priority claim(s) or which is cited to establish the publication date of another citation or other special reason (as specified)

"Y" document of particular relevance; the claimed invention cannot be considered to involve an inventive step when the document is combined with one or more other such documents, such combination being obvious to a person skilled in the art

"O" document referring to an oral disclosure, use, exhibition or other means

"&" document member of the same patent family

"P" document published prior to the international filing date but later than the priority date claimed

Date of the actual completion of the international search
17 September 2007

Date of mailing of the international search report

27 MAR 2008

Name and mailing address of the ISA/US
Mail Stop PCT, Attn: ISA/US
Commissioner for Patents
P.O. Box 1450, Alexandria, Virginia 22313-1450
Facsimile No. 571-273-3201

Authorized officer:

Blaine R. Copenheaver

Helpdesk: 571-272-4300
PCT OSP: 571-272-7774

INTERNATIONAL SEARCH REPORT

International application No.

PCT/US2007/000607

C (Continuation). DOCUMENTS CONSIDERED TO BE RELEVANT		
Category*	Citation of document, with indication, where appropriate, of the relevant passages	Relevant to claim No.
A	US 5297654 A (DE FORGES DE PARNY et al.) 29 March 1994	1 - 12
A	EP 1551086 A1 (REELS BVBA) 6 July 2005	7 - 10
A	GB 2313592 A (KARL SCHAEFF GMBH & CO MASCHINENFABRIK) 3 December 1997	7 - 10

INTERNATIONAL SEARCH REPORT

Information on patent family members

International application No.

PCT/US2007/000607

This Annex lists the known "A" publication level patent family members relating to the patent documents cited in the above-mentioned international search report. These particulars are merely given for the purpose of information.

Patent Document Cited in Search Report		Patent Family Member			
WO	2004079877	GB	2414601		
US	2005133244	AU	2004302823	CA	2537218
		EP	1661220	EP	1724889
		EP	1724891	EP	1724892
		EP	1739803	EP	1795769
		WO	2005022714		
WO	03005516	BR	0210987	CA	2449271
		EP	1396057	KR	2001008495
		US	7216850	US	2004168816
US	5297654	CA	2067456	EP	0511909
		NO	921650	FR	2675963
EP	1551086				
GB	2313592	CN	1170982	IT	MI971184
				JP	10072164
END OF ANNEX					