

March 26, 1963

S. UPTHAGROVE

3,082,437

NOVELTY BEACH MAT

Filed March 8, 1961

2 Sheets-Sheet 1

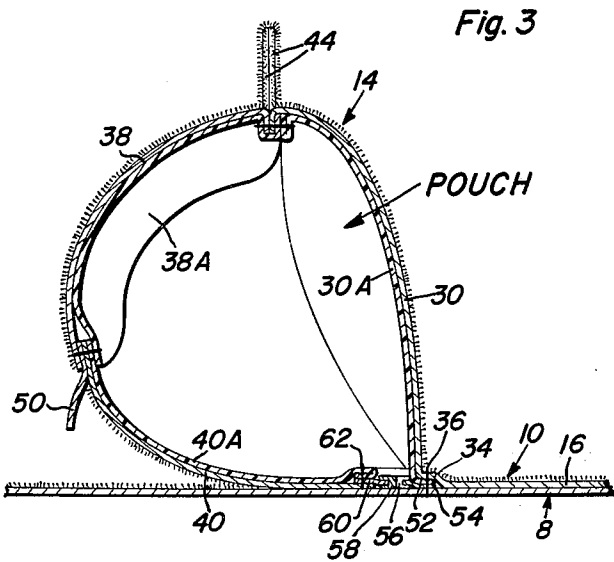
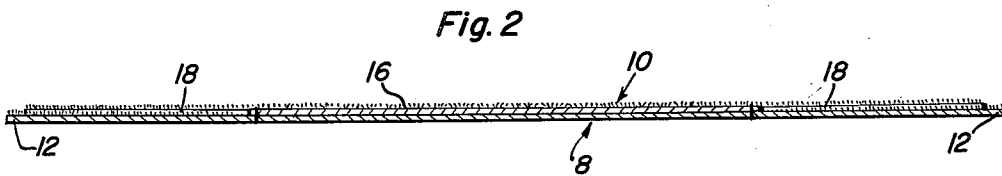
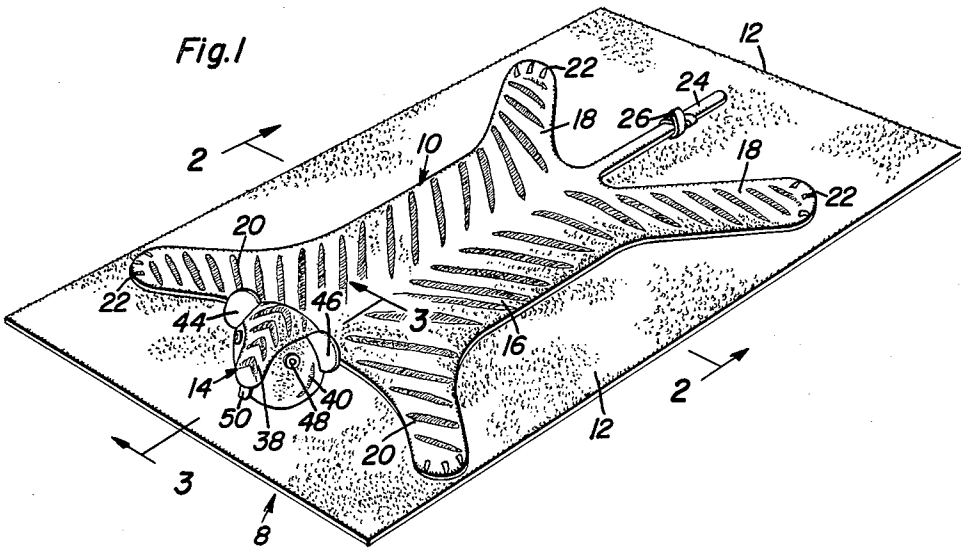

Suzen Upthagrove
INVENTOR.

BY *Alvanco A. Orin*
and Harvey B. Jackson
Attorneys

March 26, 1963

S. UPTHAGROVE

3,082,437

NOVELTY BEACH MAT

Filed March 8, 1961

2 Sheets-Sheet 2

Fig. 4

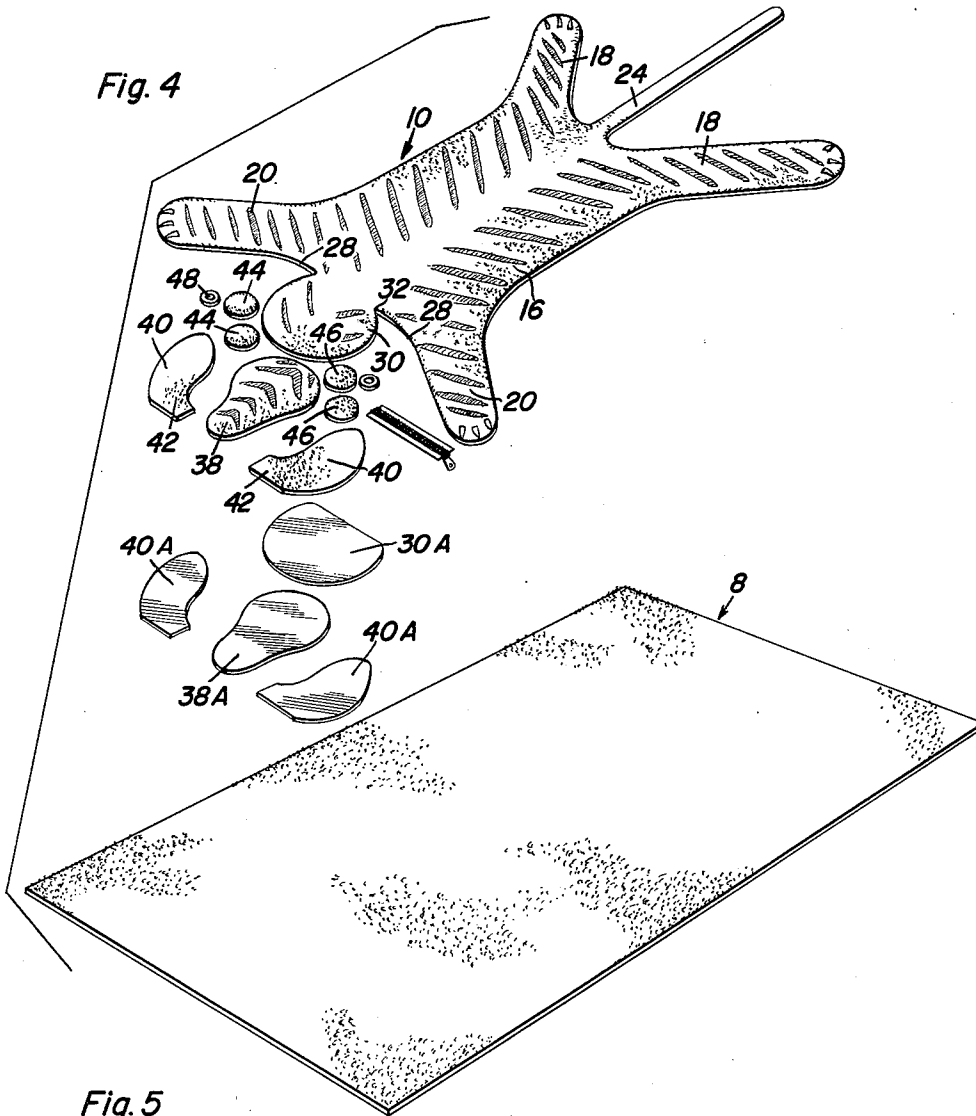
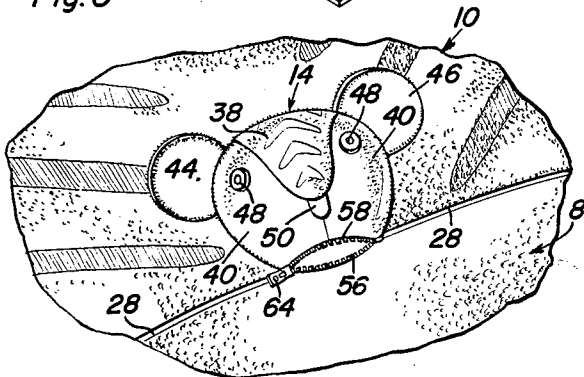

Fig. 5



Suzen Upthagrove

INVENTOR.

BY *Clarence A. Brown*
and *Harvey B. Jacobson*
Attorneys

1

3,082,437

NOVELTY BEACH MAT

Suzen Uptisgrove, 1325 S. Church St.,
Stevens Point, Wis.

Filed Mar. 8, 1961, Ser. No. 94,211

6 Claims. (Cl. 5-344)

This invention relates to a novelty-type reclining mat primarily for use when basking in the sun at the beach or wherever else the intended user finds pleasurable use therefor, and has to do, more particularly, with a mat which is unique in that it is equipped with added facilities which contribute to improved usefulness as well as original appearance.

An object of the invention is to initiate a new concept in beach mats and to thus make available a specially contrived adaptation which is destined to become an innovation in that it is conducive to merriment, by reason of its unusual appearance, but is highly useful too. To these ends, one new and useful result is attained by providing a reclining terry cloth pad atop an ordinary mat made of toweling or the like, said pad serving to bolster up the strength of the mat and, at the same time, offering added comfort by using terry cloth having an acceptably soft pile.

In carrying out the utility aspect of the invention the pad embodies a desirable feature; namely, it includes a hollow pouch which is attached to a forward end portion of the pad. This pouch serves to accommodatingly hold and carry small articles such as a towel, bathing suit and cap, and while the user is bathing, it may then be used to store a comb and brush, compact or whatever else one cares to place therein. Then, too, the pouch is lined with waterproof plastic or equivalent material so that a wet towel and bathing suit may be conveniently stored when returning from the beach.

An equally important improvement resides in the fact that the aforementioned pad is expressly cut out and marginally delineated so that said pad may serve as an attractive imitation "animal skin," for example, and as herein shown, an animal skin in a representation of a tiger. It follows that in order to achieve this novel result, tiger-print terry cloth is used. Moreover, the pouch is not only an article pocket, it is made up of sewed components of prerequisite shape and design whereby the tiger's head is thus provided. Furthermore, the head is an integral part of the pad, is hinged in a novel way so that it is movable and at the hinge-point an openable and closable entrance opening or mouth is provided. Thus constructed and featured, the overall mat serves the novel purposes for which this invention is intended when in use.

Briefly, the invention comprises a beach mat made of toweling and adapted to be spread flatwise on a surface, a terry cloth pad superimposed atop and fastened to said mat and carrying a movably attached article storing pouch, the latter having the additional function of a pillow.

These together with other objects and advantages which will become subsequently apparent reside in the details of construction and operation as more fully hereinafter described and claimed, reference being had to the accompanying drawings forming a part hereof, wherein like numerals refer to like parts throughout, and in which:

FIGURE 1 is a view in perspective of the improved novelty beach mat illustrating the same in its spread ready-to-use position wherein, as will be noticed, the head-forming pouch is in a face-down position where it functions as a head rest or pillow.

FIGURE 2 is a view on an enlarged scale taken on the section line 2—2 of FIGURE 1;

2

FIGURE 3 is an exaggerated view with parts in section and elevation and fragmentarily presented and taken on the plane of the line 3—3 of FIGURE 1;

FIGURE 4 is an exploded perspective view wherein all of the component elements or parts are presented; and

FIGURE 5 is a fragmentary view also in perspective, the purpose of the view being to show how the pouch forming head is bodily moved or lifted up to a position to show the openable and closable mouth and its orientation in respect to the adjacent cooperating parts.

With reference to FIGURE 1 the beach mat proper is denoted by the numeral 8. This mat is made of toweling or equivalent launderable material and in practice may be 63 inches long and 36 inches wide. The aforementioned added lamination or pad is denoted generally by the numeral 10. This pad is superimposed atop the mat and is stitched or otherwise fastened in place. The term "pad" is used here to desirably convey the idea that the inventive concept comprehends, not necessarily the particular tiger-shaped pad illustrated but any other pad for strengthening and cushioning and adding to the comfort of the combined mat and attached pad. By preference the pad is made of a durable grade of deep pile terry cloth. It is symmetrically centered on the mat so that the marginal edge portions of the mat denoted at 12 project beyond the marginal edge portions of the pad. At one end, preferably the leading or forward end, the pad is provided with a specially designed and multipurpose small article containing, storing and carrying pouch and this is denoted generally by the reference numeral 14. Actually the pouch is an integral part of the central transverse end portion of the pad.

More in particular the pad comprises a specially delineated pattern or cutout which renders the pad distinctive in design and appearance and while some other figure could be represented within the purview of the invention, an animal, for instance a tiger, is represented. It is within the scope of the inventive concept to construe the specially delineated pad 10 as an imitation animal skin, the same being sprawled flatwise to impart the desired prone animal skin effect.

The tiger-shaped pad or animal skin depicted represents a tiger the body portion thereof being denoted at 16, the hind legs at 18, the front legs at 20, these legs being ornamentally stitched down or sewn in place as at 22 for artistic effect. The tail 24 may be allowed to remain loose and tied into a knot as at 26 to give it a whimsical touch. As shown in FIG. 4 the marginal edge portion which may be designated as the leading end and providing shoulders is preferably that shown, the shoulders being designated at 28. At this point a substantially disc-like flap 30 is provided and the neck portion thereof 32 is centrally joined to the edge embodying the shoulders. This tab or flap is an essential component of the unique pouch-type head. It is best shown in FIG. 3 wherein it will be noted that it is directed upwardly in relation to the horizontal plane, the fold line or bent portion being denoted at 34. This folded portion is stitched down in place as at 36. The added terry cloth component parts which are fitted and sewn together in the manner illustrated are shown in FIG. 4. The cutout patch designated at 38 defines the forehead and face and nose. The duplicate face and cheek components 40 have their end portions 42 butted together and sewn in the manner illustrated best in FIG. 5. When these several parts 38 and 40 are assembled and sewn the effect is that seen in FIGS. 1 and 5. The small disks 44 and 46 are sewn together to define ears which are stitched in place in the seam in the manner seen in FIG. 3. Suitable buttons 48 are used for eyes. The entire interior of the hollow head and pouch thus made up is lined with waterproof material, for example, a suitable grade of commercial plastics. The

outout 30A cooperates with and lines the surface of the flap 30. The one denoted at 38A conforms with the piece 38 referred to and the remaining pieces or cutouts 40A obviously conformingly fit with the pieces 40 already described. Incidentally, the numeral 50 designates a red flannel tongue to complete the desired animated or life-like effect of the tiger. It is important to note, however, that an edge 52 (FIG. 3) of the plastic sheet 30A is secured by the same stitching 36 already mentioned and the stitching also secures in place one of the tapes 54 of the slide fastener or so-called zipper. The track on this tape is denoted at 56 and is opposed to the track 58 which is carried by the other tape 60 stitched in place as at 62 thus securing the several component parts together to define an openable and closable mouth or opening at the hinge point, that is the adjacent edge embodying the shoulders 28.

When the zipper is closed and the head or pouch is face down and, assuming that it is suitably filled (not shown) it constitutes a headrest or pillow as is obvious. By moving the head up to expose the mouth as seen in FIG. 5 and opening the mouth by moving the slide fastener 64 the mouth may be opened at the hinge point to permit articles to be inserted or removed in what is believed to be an obvious manner.

The foregoing is considered as illustrative only of the principles of the invention. Further, since numerous modifications and changes will readily occur to those skilled in the art, it is not desired to limit the invention to the exact construction and operation shown and described, and accordingly all suitable modifications and equivalents may be resorted to, falling within the scope of the invention as claimed.

What is claimed as new is as follows:

1. A spreadable and rollable beach mat having top and bottom surfaces, and an imitation animal skin superimposed flatwise and decoratively upon and fastened to said top surface, said mat and animal skin both being made of launderable material, said animal skin representing a given animal, a tiger for instance, and the forward end of said animal skin being spaced inwardly from the forward end of the mat and having a hollow head attached thereto, said head being interiorly lined with waterproof material and constituting a pouch in which small articles of bathing attire and the like may be stored and carried, said head embodying a neck portion which is hingedly attached to a cooperating portion of said mat and being independently movable and, when suitably filled and positioned in a predetermined face-down manner, has the additional function of a head resting pillow.

2. The structure defined in claim 1, and wherein said beach mat is rectangular in plan and is made of launderable toweling, said pouch being likewise made of toweling, being situated at said forward end portion of the mat midway between the lengthwise edge of said mat and being of a size in plan that it is properly adapted to function as a pillow for the user's head.

3. For use atop a terry cloth beach mat, a prefabricated soft pad made of terry cloth and marginally delineated

to represent a predetermined figure, said pad adapted to be sewed in a useful symmetrical position atop said mat to thicken, strengthen and decorate the mat, a median portion of the forward end of said pad having an integral flexibly joined disk-like flap and prescribed cooperating terry cloth component parts attached to each other and carried by said flap and transforming the same into a hollow head which is applicable to and in keeping with the figure which is being represented, the marginal delineation and resultant configuration with the pad being such that it constitutes an imitation animal skin attached to and assuming a prone position on the mat, said head being hinged in place through the medium of the attached flap, having an openable and closable mouth situated at the point of attachment, and being lined interiorly with waterproof sheet plastic material.

4. The structure according to claim 3, and wherein said head is of a size that the hollow portion constitutes a storing and carrying pouch for beach wear and small usable articles, and also ample in size that it may be usable as a pillow for the user's head, and said mouth having openable and closable edge portions thereof provided with readily accessible slide-fastener type opening and closing means.

5. A novelty beach mat comprising a relatively large beach towel made of spreadable launderable material and constituting the mat proper, a second towel also made of launderable material and superimposed and secured flatwise atop the first-named towel and having all of its marginal edges spaced inwardly from the corresponding marginal edges of said first-named towel, said first-named towel being substantially rectangular in plan, the second towel being unique in plan, constituting a pad and the outline being such that it represents a given creature, the median portion of a transverse end of said second towel having an article storing and carrying pouch hingedly joined thereto, said pouch having an openable and closable mouth, the latter being located at the juncture of the pouch with said second towel and normally concealed and in fact inaccessible until the pouch is intentionally moved to assume a prescribed position relative to the adjacent cooperating portions of the two towels.

6. The structure according to claim 5, and wherein said towels are of a size that the overall mat is susceptible of use not only for reclining on a beach but also in the capacity of a cape-like serape, said pouch being of a size and shape relative to the second towel that it constitutes a suitable head for the creature defined by said second towel, and also wherein the components defining said mouth are provided with cooperating components defining readily openable and closable fastener means.

References Cited in the file of this patent
UNITED STATES PATENTS

2,264,471	Glenn	Dec. 2, 1941
2,540,165	Fiel	Feb. 6, 1951
2,727,242	Pascal	Dec. 20, 1955
2,898,609	Storie	Aug. 11, 1959