



- (51) International Patent Classification:
A61B 17/3207 (2006.01)
- (21) International Application Number:
PCT/US2013/069045
- (22) International Filing Date:
8 November 2013 (08.11.2013)
- (25) Filing Language: English
- (26) Publication Language: English
- (30) Priority Data:
13/671,695 8 November 2012 (08.11.2012) US
- (71) Applicant: COVIDIEN LP [US/US]; 15 Hampshire Street, Mansfield, MA 02048 (US).
- (72) Inventors: GUGGENHEIMER, Ethan, A.; 4238 Washburn Avenue North, Minneapolis, MN 55412 (US). SCHNEIDER, Lucas; 7623 118th Avenue North, Champlin, MN 55316 (US). MCPEAK, Thomas; 389 Alexander Court, Shakopee, MN 55379 (US). FRULAND, Benjamin; 12079 Dunkirk Street NE, Blaine, MN 55449 (US).
- (74) Agents: BERGMAN, Alana et al.; Covidien LP, 15 Hampshire Street, Mansfield, MA 02048 (US).
- (81) Designated States (unless otherwise indicated, for every kind of national protection available): AE, AG, AL, AM,

AO, AT, AU, AZ, BA, BB, BG, BH, BN, BR, BW, BY, BZ, CA, CH, CL, CN, CO, CR, CU, CZ, DE, DK, DM, DO, DZ, EC, EE, EG, ES, FI, GB, GD, GE, GH, GM, GT, HN, HR, HU, ID, IL, IN, IR, IS, JP, KE, KG, KN, KP, KR, KZ, LA, LC, LK, LR, LS, LT, LU, LY, MA, MD, ME, MG, MK, MN, MW, MX, MY, MZ, NA, NG, NI, NO, NZ, OM, PA, PE, PG, PH, PL, PT, QA, RO, RS, RU, RW, SA, SC, SD, SE, SG, SK, SL, SM, ST, SV, SY, TH, TJ, TM, TN, TR, TT, TZ, UA, UG, US, UZ, VC, VN, ZA, ZM, ZW.

- (84) Designated States (unless otherwise indicated, for every kind of regional protection available): ARIPO (BW, GH, GM, KE, LR, LS, MW, MZ, NA, RW, SD, SL, SZ, TZ, UG, ZM, ZW), Eurasian (AM, AZ, BY, KG, KZ, RU, TJ, TM), European (AL, AT, BE, BG, CH, CY, CZ, DE, DK, EE, ES, FI, FR, GB, GR, HR, HU, IE, IS, IT, LT, LU, LV, MC, MK, MT, NL, NO, PL, PT, RO, RS, SE, SI, SK, SM, TR), OAPI (BF, BJ, CF, CG, CL, CM, GA, GN, GQ, GW, KM, ML, MR, NE, SN, TD, TG).

- Published:
- with international search report (Art. 21(3))
 - before the expiration of the time limit for amending the claims and to be republished in the event of receipt of amendments (Rule 48.2(h))

(54) Title: TISSUE-REMOVING CATHETER WITH ROTATABLE CUTTER

FIG. 18

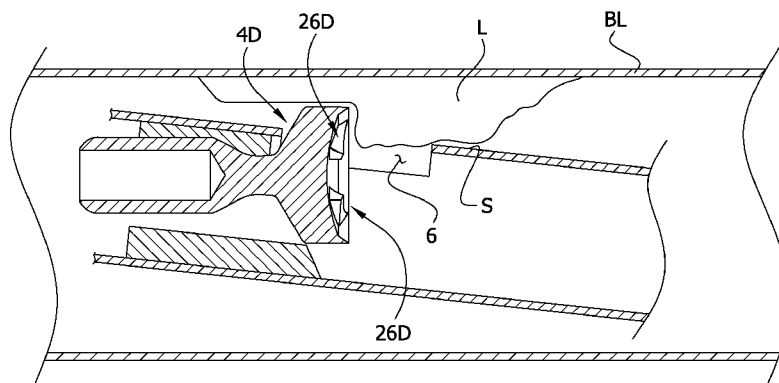

(57) Abstract: A tissue -removing catheter includes a cutting element. The cutting element may be extendable through the window during operation such that as the cutting element is being rotated about its longitudinal axis, less than an entire radial portion of the leading radial wall passes through the window. A radially innermost portion of the leading radial wall of a raised element of the cutting element may be spaced a radial distance from the longitudinal axis that is less than 66% of the radius of the annular cutting edge. A plurality of abrading members may be formed on at least the central portion of the inner surface of the cutting element to abrade hardened tissue as the cutting element is rotating about its longitudinal axis. A radially outermost portion of the leading radial edge of the raised element may be spaced apart radially from an inner surface of the cutting element.

WO 2014/074768 A1

TISSUE-REMOVING CATHETER WITH ROTATABLE CUTTER

FIELD OF THE DISCLOSURE

[0001] The present invention generally relates to tissue-removing catheter with a rotatable cutter.

BACKGROUND

[0002] Catheters are used to remove unwanted tissue from the body. As an example, atherectomy catheters are used to remove material from a blood vessel to open the blood vessel and improve blood flow through the vessel.

SUMMARY

[0003] In one aspect, a tissue-removing catheter generally comprises an elongate catheter body having opposite distal and proximal portions and being sized and shaped for introduction into a body lumen of a subject. A drive shaft extends longitudinally within the catheter body. The drive shaft is rotatable relative to the catheter body about a longitudinal axis of the drive shaft. A cutting element at the distal portion of the elongate catheter body has opposite proximal and distal ends and a longitudinal axis extending therebetween. The cutting element is operatively connected to the drive shaft for rotation about a longitudinal axis of the cutting element. The cutting element includes an annular cutting edge at the distal end of the cutting element surrounding the longitudinal axis of the cutting element. The annular cutting edge has a radius as taken from the longitudinal axis of the cutting element. An inner surface of the cutting element extends proximally from the cutting edge and defines an internal cavity. At least one raised element in the internal cavity of the cutting element extends generally longitudinally outward from the inner surface. The at least one raised element includes a leading radial wall extending generally radially inward toward the longitudinal axis of the cutting element. The leading radial wall has a radially outermost portion relative to the longitudinal axis of the cutting element, a radially innermost portion relative to the longitudinal axis of the cutting element, and a radial length extending between the radially outermost and innermost portions. The radially innermost portion of the leading radial wall is spaced a radial distance from the longitudinal axis that is less than 66% of the radius of the annular cutting edge.

[0004] In another aspect, a tissue-removing catheter generally comprises an elongate catheter body having opposite distal and proximal portions and being sized and shaped for introduction into a body lumen of a subject. The catheter body has a window at the distal portion thereof. A drive shaft extends longitudinally within the catheter body. The drive shaft is rotatable relative to the catheter body about a longitudinal axis of the drive shaft. A cutting element at the distal portion of the elongate catheter body is adjacent the window. The cutting element has opposite proximal and distal ends and a longitudinal axis extending therebetween, the cutting element being operatively connected to the drive shaft for rotation about the longitudinal axis of the cutting element. The cutting element includes an annular cutting edge at the distal end of the cutting element surrounding the longitudinal axis of the cutting element, the annular cutting edge having a radius as taken from the longitudinal axis of the cutting element. An inner surface of the cutting element extends proximally from the cutting edge and defining an internal cavity. At least one raised element in the internal cavity has leading radial wall extending generally radially inward toward the longitudinal axis of the cutting element. The cutting element is extendable through the window during operation such that as the cutting element is being rotated about its longitudinal axis, less than an entire radial portion of the leading radial wall passes through the window.

[0005] In another aspect, a tissue-removing catheter generally comprises an elongate catheter body having opposite distal and proximal portions and being sized and shaped for introduction into a body lumen of a subject. A drive shaft extends longitudinally within the catheter body, wherein the drive shaft is rotatable relative to the catheter body about a longitudinal axis of the drive shaft. A cutting element at the distal portion of the elongate catheter body has opposite proximal and distal ends and a longitudinal axis extending therebetween. The cutting element is operatively connected to the drive shaft for rotation about a longitudinal axis of the cutting element. The cutting element includes an annular cutting edge at the distal end of the cutting element surrounding the longitudinal axis of the cutting element. The annular cutting edge has a radius as taken from the longitudinal axis of the cutting element. An inner surface extends proximally from the cutting edge and defining an internal cavity. At least one raised element in the internal cavity extends generally longitudinally outward from the inner surface. The at least one raised element includes a leading radial wall extending generally radially inward toward the longitudinal axis of the cutting element. The leading radial wall has a

radially outermost portion relative to the longitudinal axis of the cutting element, a radially innermost portion relative to the longitudinal axis of the cutting element, and a radial length extending between the radially outermost and innermost portions. The radially outermost portion is spaced apart radially from the inner surface of the cutting element.

[0006] Other features will be in part apparent and in part pointed out hereinafter.

BRIEF DESCRIPTION OF THE DRAWINGS

[0007] FIG. 1 is a perspective of a distal end of an atherectomy catheter;

[0008] FIG. 2 is an enlarged fragmentary section of the atherectomy catheter of FIG. 1 with a cutting element in a stowed position;

[0009] FIG. 3 is the enlarged fragmentary section of FIG. 1 but with a cutting element in a working position;

[0010] FIG. 4 is a perspective of an embodiment of a cutting element;

[0011] FIG. 5 is an enlarged end view of the cutting element;

[0012] FIG. 6 is a longitudinal section of the cutting element of Fig. 4;

[0013] FIG. 7 is an end view of another embodiment of a cutting element, which may be used with the atherectomy catheter shown in FIG. 1;

[0014] FIG. 8 is a perspective of the cutting element of FIG. 7;

[0015] FIG. 8A is an enlarged detail of Fig. 8 showing one of the raised elements of the cutting element;

[0016] FIG. 9 is an end view of another embodiment of a cutting element, which may be used with the atherectomy catheter shown in FIG. 1;

[0017] FIG. 10 is a perspective of the embodiment of the cutting element illustrated in FIG. 9;

[0018] FIG. 10A is an enlarged detail of Fig. 10 showing of the raised elements of the cutting element embodiment;

[0019] FIG. 11 is perspective of a modified version of the embodiment of the cutting element illustrated in FIG. 8;

[0020] FIG. 11A is an enlarged detail of Fig. 11 showing one of the raised elements;

[0021] FIG. 12 is a perspective of another embodiment of a cutting element;

[0022] FIG. 13 is an end view of the cutting element of FIG. 12;

[0023] FIG. 14 is similar to FIG. 13, but enlarged and including imaginary circles for determining radial distances and radial lengths;

[0024] FIG. 15 is an enlarged, fragmentary view of FIG. 14;

[0025] FIG. 16 is similar to FIG. 13, but including a schematic representation of the catheter body;

[0026] FIG. 17 is similar to FIG. 16, except the schematic representation of the catheter body is shown in phantom;

[0027] FIG. 18 is a fragmentary, longitudinal section of a catheter including the cutting element of FIG. 12 removing tissue from a body lumen;

[0028] FIG. 19 is a perspective of another embodiment of a cutting element;

[0029] FIG. 20 is a perspective of another embodiment of a cutting element;

[0030] FIG. 21 is a perspective of another embodiment of a cutting element;

[0031] FIG. 22 is an end view of the cutting element of FIG. 21;

[0032] FIG. 23 is an enlarged, fragmentary section of the cutting element taken in the plane containing the line 23--23 in FIG. 22;

[0033] FIG. 24 is an enlarged view of a raised element of the cutting element of FIG. 21;
and

[0034] FIG. 25 is a further enlarged, fragmentary view of FIG. 23.

[0035] Corresponding reference characters indicate corresponding parts throughout the drawings.

DETAILED DESCRIPTION OF THE DRAWINGS

[0036] Referring now to the drawings, several embodiments of a tissue-removing catheter for removing tissue from a body lumen are disclosed. In particular, the illustrated catheter embodiments are suitable for removing tissue from a body lumen wall, and are particularly suitable for removing (i.e., excising) plaque tissue from a vessel wall (e.g., peripheral arterial or peripheral venous wall). Features of the disclosed embodiments, however, may also be suitable for treating chronic total occlusion (CTO) of blood vessels, particularly peripheral arteries, and stenoses of other body lumens and other hyperplastic and neoplastic conditions in other body lumens, such as the ureter, the biliary duct, respiratory passages, the pancreatic duct, the lymphatic duct, and the like. Neoplastic cell growth will often occur as a

result of a tumor surrounding and intruding into a body lumen. Removal of such material can thus be beneficial to maintain patency of the body lumen. While the remaining discussion is directed toward catheters for removing tissue from and penetrating occlusions in blood vessels (e.g., atheromatous or thrombotic occlusive material in an artery, or other occlusions in veins), it will be appreciated that the teachings of the present disclosure apply equally to other types of tissue-removing catheters, including, but not limited to, catheters for penetrating and/or removing tissue from a variety of occlusive, stenotic, or hyperplastic material in a variety of body lumens.

[0037] Referring to FIGS. 1 to 4, an atherectomy catheter 2, which has a cutting element 4, which is used to cut material from a blood flow lumen. The catheter has an elongate body 8 having distal and proximal portions and being sized and shaped for insertion into a body lumen of a subject. The cutting element 4 is movable between a stored position (FIG. 2) and a cutting position (FIG. 3) relative to a window or opening 6 in the catheter body 8 adjacent the distal portion. The cutting element 8 moves outwardly relative to the opening 6 so that an exposed portion of the element 4 extends outside the body 8 through the opening 6. The cutting element 4 may be positioned relative to the body 8 and opening 6 so that less than 90 degrees of the cutting element 4 is exposed to cut tissue. Of course, more of the cutting element 4 may be exposed without departing from numerous aspects of the invention.

[0038] Catheter 2 may have a maximum size of 3, 4, 5, 6, 7, 8, 9, 10, or 12 French (1, 1.3, 1.7, 2, 2.3, 2.7, 3, 3.3, or 4 mm) and may have a working length ranging of 20, 30, 40, 60, 80, 100, 120, 150, 180 or 210 cm depending on the requirements of the anatomical location in which use of the catheter is contemplated. Cutter 4 preferably has a diameter slightly less than that of the maximum size of catheter 2, typically 0.010" (0.025 cm), 0.015" (0.038 cm), 0.020" (0.051 cm), 0.025" (0.064 cm) or 0.030" (0.076 cm) less. However these relative dimensions are not meant to be limiting.

[0039] The catheter 2 is moved distally through a vessel with the cutting element 4 in the working or cutting position as described in further detail below. As the catheter 2 moves through the blood vessel, the tissue is cut by the cutting element 4 and is directed into a tissue chamber 12 positioned distal to the cutting element 4. The tissue chamber 12 may be somewhat elongate to accommodate the tissue that has been cut.

[0040] The cutting element 4 is moved proximally from the stored position so that a cam surface 14 on the cutting element 4 engages a ramp 16 on the body 8 of the catheter 2. The interaction between the cam surface 14 and the ramp 16 causes the cutting element 4 to move to the cutting position and also causes a tip 18 to deflect which tends to move the cutting element 4 toward the tissue to be cut.

[0041] The cutting element 4 is coupled to a drive shaft 20 that extends through a lumen 21 in the catheter 2. The cutting element 4 is rotated about a longitudinal axis LA when the drive shaft rotates about its longitudinal axis. The cutting element 4 is rotated at about 1 to 160,000 rpm but may be rotated at any other suitable speed depending upon the particular application.

[0042] Referring to FIGS. 2, 4 and 5, the cutting element 4 is shown. The term “along the longitudinal axis” as used herein shall mean the view of FIG. 5 that shows the distal end of the cutting element 4 when viewed in the direction of the longitudinal axis and/or the axis of rotation. The cutting element 4 has an annular cutting edge 22 that may be a continuous, uninterrupted, circular-shaped edge although it may also include ridges, teeth, serrations or other features without departing from the scope of the invention. The cutting edge 22 may be at a radially outer edge 23 of the cutting element 4 when the cutting element 4 is in the cutting position. A circumferential inner surface 25 of the cutting element 4 extends from the cutting edge 22 and is chamfered or beveled.

[0043] The cutting element 4 has an inner cup-shaped surface 24, which directs the tissue cut by the cutting edge 22 into the tissue chamber 12. In the illustrated embodiment, the circumferential inner surface and the inner cup-shaped surface 24 define an internal cavity of the cutting element 4. The cup-shaped surface 24 may be a smooth and continuous surface free of through-holes, teeth, fins or other features, which disrupt the smooth nature of the surface 24 for at least half the distance from the longitudinal axis LA to the outer radius at the cutting edge 22. The cup-shaped surface 24 may also be free of any such features throughout an area of at least 300 degrees relative to the longitudinal axis LA.

[0044] Cutter 4 may be comprised of steel, tungsten carbide, tungsten carbide cobalt, tungsten carbide molybdenum, silicon carbide, silicon nitride, ceramic, amorphous metals or other materials and may be manufactured by methods including turning, grinding, sintering, electro-discharge machining (EDM), laser cutting, heat treating, precipitation hardening, casting or other methods.

[0045] Referring to FIGS. 4 to 6, one or more raised elements 26 extend outwardly from the cup-shaped surface 24 with FIG. 5 showing two raised elements 26. The raised element 26 is a small wedge of material that rises relatively abruptly from the cup-shaped surface 24. The raised element 26 has a first wall 30 and a second wall 32 that both extend radially and form an angle of about 20 degrees therebetween so that the two raised elements 26 together occupy an area of about 40 degrees and altogether may be less than 60 degrees. A third wall 34 extends between the radially inner portion of the first and second walls 30, 32. The raised element 26 helps to break up hard tissue and plaque by applying a relatively blunt force to the hard tissue or plaque since cutting such tissue with the cutting edge 22 is often not effective.

[0046] The raised elements 26 altogether occupy a relatively small part of the cup-shaped surface 24. The raised elements 26 together may occupy less than 5% of a surface area of the cutting element 4. The term “surface area of the cutting element” as used herein shall mean the surface area which is radially inward from the outer or cutting edge 22 and is exposed when viewed along the longitudinal axis LA. Stated another way, at least 95% of the surface area of the cutting element is a smooth cup-shaped surface when viewed along the longitudinal axis. However, the raised element surface area may occupy more of the total surface area of the cup. By sizing and positioning the raised element 26 in this manner, the raised element 26 does not interfere with the ability of the cutting element 4 to cut and re-direct tissue into the tissue chamber while still providing the ability to break up hard tissue and plaque with the raised element 26.

[0047] The raised element 26 may be recessed from the cutting edge 22 longitudinally and/or radially. The raised element 26 may be recessed longitudinally (along axis LA) from the cutting edge 0.0010 to 0.0020 inch (0.0025 cm to 0.0051 cm) and may be recessed about 0.0015 inch (0.0038 cm). The raised element 26 may be recessed radially from the cutting edge 22 by about the same amount. A distal wall 38 of the cutting element 4 forms a flat surface 40, which is perpendicular to the longitudinal axis LA so that the entire surface is recessed the same distance from the cutting edge. The distal wall 38 may take any other shape, such as a curved shape, or may be tilted, inclined or beveled as now described. The raised element may have other shapes, sizes and locations within the scope of the present invention.

[0048] Referring to FIGS. 7, 8 and 8A, another cutting element 4A is shown wherein the same or similar reference numbers refer to the same or similar structure and all discussion

concerning the same or similar features of the cutting element 4 are equally applicable here unless noted otherwise. The cutting element 4A has a cutting edge 22A that may be a continuous, uninterrupted, circular-shaped edge although it may also include ridges, teeth, serrations or other features without departing from the scope of the invention. The cutting edge 22A may be at a radially outer edge 23A of the cutting element 4A when the cutting element 4A is in the cutting position. The cutting element 4A has a cup-shaped surface 24A that directs the tissue cut by the cutting edge 22A into the tissue chamber 12 (see FIG. 2). The cup-shaped surface 24A may be a substantially smooth and continuous surface as described above in connection with the cutting element 4.

[0049] One or more raised elements 26A extend outwardly from the cup-shaped surface 24A. FIG. 8 shows four raised elements 26A but may include any number such as 1, 2, 3, 4, 6 or 8 raised elements. The raised element 26A is a small wedge of material that rises relatively abruptly from the cup-shaped surface 24A. The raised element 26A has a first wall 30A and a second wall 32A which, in one embodiment, both extend radially and form an angle of about 1 to 30 degrees therebetween so that the four raised elements 26A together occupy an area of about 4 to 60 degrees and altogether may be less than 60 degrees. A third wall 34A extends between the radially inner portion of the first and second walls 30A, 32A. In some embodiments the raised elements 26A may occupy a relatively small part of the cup-shaped surface 24A and may be recessed from the cutting edge 22A in the manner described above in connection with the cutting element 4. In other embodiments at least 60%, 70%, 80% or 90% of the surface area of the cutting element is a smooth cup-shaped surface.

[0050] A distal wall 38A of the cutting element 4A has a surface 40A that forms an angle of about 30 to 90 degrees with respect to the longitudinal axis LA. The entire surface 40A may still be somewhat close to but recessed from the cutting edge 22A so that the entire surface 40A is at least 0.0010, 0.0020, 0.0030, 0.0040 or 0.0050 inches (0.0025, 0.0051, 0.0076, 0.0101, or 0.0127 cm) from the cutting edge. A leading edge 50 formed at the intersection of wall 30A and distal wall 38A is closer to the cutting edge 22A than an edge 52 formed at the intersection of wall 32A and distal wall 38A. The cutting element 4A may be rotated in either direction so that the raised edge 50 may be the leading or trailing edge. In some embodiments the raised edge may be 0.0010 to 0.0020 inch (0.0025 to 0.0051 cm) from the cutting edge. The raised elements 26A may all be formed in the same manner or may be different from one another. For example, some

of the elements 26A could be angled in different directions so that two of the elements have the raised edge 50 as the leading edge and two of the elements 26A have the raised edge 50 as the trailing edge. The raised elements 26A may also subtend different angles, be of different heights or may have different radial lengths without departing from various aspects of the present invention.

[0051] Referring to FIGS. 9, 10 and 10A, another cutting element 4B is shown wherein the same or similar reference numbers refer to the same or similar structure and all discussion concerning the same or similar features of the cutting element 4 are equally applicable here unless noted otherwise. The cutting element 4B has a cutting edge 22B that may be a continuous, uninterrupted, circular-shaped edge although it may also include ridges, teeth, serrations or other features without departing from the scope of the invention. The cutting edge 22B may be at a radially outer edge 23B of the cutting element 4B when the cutting element 4B is in the cutting position. The cutting element 4B has a cup-shaped surface 24B that directs the tissue cut by the cutting edge 22B into the tissue chamber 12 (see FIG. 2). In one embodiment the cup-shaped surface 24B may be a substantially smooth and continuous surface as described above in connection with the cutting element 4.

[0052] One or more raised elements 26B, extend outwardly from the cup-shaped surface 24B. FIGS. 9 and 10 show four raised elements 26B but may include any number such as 1, 2, 3, 4, 6 or 8 raised elements. The raised element 26B is a small wedge of material that rises relatively abruptly from the cup-shaped surface 24B and which subtends an arc of about 1 to 30 degrees relative to axis LA, the four raised elements 26B subtending an arc of about 4 to 60 degrees altogether. The raised element 26B has a first wall 30B that extends between a curved leading edge 50B and cup-shaped surface 24B and also has a second wall 32B which extends radially relative to axis LA. A third wall 34B extends between the radially inner portion of the first and second walls 30B, 32B. In some embodiments the raised elements 26B may occupy a relative small part of the cup-shaped surface 24B and may be recessed from the cutting edge 22B in the manner described above in connection with the cutting element 4. In other embodiments at least 60%, 70%, 80% or 90% of the surface area of the cutting element is a smooth cup-shaped surface.

[0053] A distal wall 38B of the cutting element 4B has a surface 40B that forms an angle of less than 90 degrees with respect to the longitudinal axis LA. In some embodiments the

surface 40B is angled such that edge 50B is more distal than edge 52B. The entire surface 40B may still be somewhat close to but recessed from the cutting edge 22B so that the entire surface 40B is from 0.0010 to 0.0050 inch (0.0025 to 0.0127 cm), including 0.0010, 0.0020, 0.0030, 0.0040 or 0.0050 inch (0.0025, 0.0051, 0.0076, 0.0101, or 0.0127 cm), from the cutting edge. An edge 50B formed at the intersection of wall 30B and distal wall 38B is closer to the cutting edge 22B than an edge 52B formed at the intersection of wall 32B and distal wall 38B. The included angle between wall 30B and surface 40B, in the vicinity of edge 50B, is greater than 90 degrees. The cutting element 4B may be rotated in either direction so that the raised edge 50B may be the leading or trailing edge. In one embodiment, the cutter 4B is rotated in the direction of arrow R so that edge 50B is the leading edge. Raised edges 50B, 52B may be 0.0010 to 0.0020 inch (0.0025 to 0.0051 cm) from the cutting edge. The raised elements 26B may all be formed in the same manner or may be different from one another. For example, some of the elements 26B could be angled in different directions so that two of the elements have the raised edge 50B as the leading edge and two of the elements 26A have the raised edge 50B as the trailing edge. The raised elements 26B may also subtend different angles, be of different heights or may have different radial lengths without departing from various aspects of the present invention.

[0054] In one embodiment cutter 4B is rotated in the direction of arrow R and pushed distally to force cup-shaped surface 24B and raised elements 26B into contact with material such as atheroma or plaque. Raised elements 26B will tend to concentrate cutting force along edge 50B due to relief angle between cutter axis LA and surface 40B. Cutter 4B will tend to scrape away material such as atheroma or plaque rather than cut into this material due to the obtuse included angle between wall 30B and surface 40B, in the vicinity of edge 50B. Material contacted by raised elements 26B will tend to be directed toward axis LA by surface 30B which curves from a relatively tangential angle near edge 22B to a relatively radial angle near edge 34B.

[0055] Referring to FIGS. 11 and 11A, another cutting element 4C is shown. Cutting element 4C is a modified version of cutting element 4A. The modification consists of adding an undercut 41C to the leading face of one or more raised element 26A, resulting in modified raised element 26C. When cutter 4C is rotated in the direction of arrow T the undercut directs particles of material into the concave cavity defined by cup-shaped surface 24A of the cutter, and toward axis LA of the cutter. Optionally an undercut can be applied to the leading face of one or more

raised element 26, 26B of cutting elements 4, 4B respectively as well as to one or more raised elements 26A of cutting element 4A.

[0056] Undercut 41C is defined by wall 30C which is oriented at an acute angle to surface 40A, which intersects cup-shaped surface 24A, and which meets wall 34A. The plane of wall 30C also intersects axis LA at less than 5, 10, 15, or 20 degrees such that, when cutter 4C is spinning in direction T, particles of material tend to travel along wall 30C in directions away from cutting edge 22A and toward axis LA. In some embodiments wall 43C may be interspersed between the intersection of wall 30C and wall 40A. Wall 43C may be oriented at any desired rake angle, such as for example a negative rake angle where the raised element will tend to not dig in to material being cut.

[0057] Referring to FIGS. 12-18, another embodiment of a cutting element is indicated generally at 4D. The cutting element 4D is similar to cutting element 4B, except that, as explained below, radial lengths of the raised elements, generally indicated at 26D, are greater than radial lengths of the raised elements 26B of the cutting element 4B. The cutting element 4D has an annular cutting edge 22D that may be a continuous, uninterrupted, arcuate-shaped edge although it may also include ridges, teeth, serrations or other features without departing from the scope of the invention. In the illustrated embodiment, an inner surface of the cutting element 4D defines an internal cavity of the cutting element. The inner surface includes a circumferential inner surface 25D, which is chamfered or beveled, extending from the cutting edge 22, and a central cup-shaped surface 24D that directs the tissue cut by the cutting edge 22D into the tissue chamber 12 (see FIG. 2). The cutting edge 22D may be at a radially outer edge 23D of the cutting element 4D when the cutting element is in the cutting position. In one embodiment the cup-shaped surface 24D may be a substantially smooth and continuous surface as described above in connection with the cutting element 4. As disclosed in another embodiment below (FIGS. 19 and 20), the cup-shaped surface 24D may be abrasive. In other embodiments, a through opening (not shown) may extend longitudinally through the cup-shaped surface 24D to direct removed tissue proximally through the cutting element 4D.

[0058] The raised elements 26D extend generally longitudinally outward from the cup-shaped surface 24B, within the internal cavity of the cutting element 4D. The embodiment illustrated in FIGS. 12-18 includes four raised elements 26D, but the cutting element 4D may include any number such as 1, 2, 3, 4, 6 or 8 raised elements. Each raised element 26D is a small

wedge of material that rises relatively abruptly from the inner surface (e.g., the cup-shaped surface 24D) and which subtends an arc of about 1 to 30 degrees relative to axis LA, the four raised elements 26D subtending an arc of about 4 to 60 degrees altogether. Referring to FIG. 13, each raised element 26D has a leading radial wall (broadly, a first wall) 30D, a trailing radial wall (broadly, a second wall) 32D, a radially inner end wall 34D (broadly, a third wall), and a distal wall (broadly, a fourth wall) 38D. The leading radial wall 30D has a depth extending longitudinally relative to the cutter 4D between the distal wall 38D and the cup-shaped surface 24D, and a radial length RL (FIG. 15) extending generally inward from adjacent the cutting edge 22D of the cutting element 4D, as explained in more detail below. The leading radial wall 30D is curved along its depth (i.e., curved longitudinally with respect to the cutting element 4D) and is also curved along its radial length RL. A leading edge 50D of the cutting element 26D is defined at the intersection of the leading radial wall 30D and the distal wall 38D. The leading edge 50D is curved radially relative to the cutter 4D. In some embodiments the raised elements 26D may occupy a relative small part of the cup-shaped surface 24D and may be recessed from the cutting edge 22D in the manner described above in connection with the cutting element 4. In other embodiments at least 60%, 70%, 80% or 90% of the surface area of the cutting element is a smooth cup-shaped surface.

[0059] The distal wall 38D of the cutting element 4D forms an angle of less than 90 degrees with respect to the longitudinal axis LA. In some embodiments the wall 38D is angled such that edge 50D is more distal than the edge defined at the intersection of the distal wall 38D and the trailing wall 32D. The entire distal wall 38D may be adjacent to, but recessed longitudinally from, the cutting edge 22D so that the distal wall is spaced a minimum longitudinal distance from about 0.0010 to about 0.0050 inch (0.0025 to 0.0127 cm), including about 0.0010, about 0.0020, about 0.0030, about 0.0040 or about 0.0050 inch (0.0025, 0.0051, 0.0076, 0.0101, or 0.0127 cm), from the cutting edge. The included angle between leading radial wall 30D and the distal wall 38D, in the vicinity of the leading edge 50D, may be greater than 90 degrees. The cutting element 4D is rotated in the direction R (FIG. 13) so that the leading edge 50D engages the tissue to be removed. As shown in FIG. 15, the leading edge 50D of the raised element 26D may be spaced a radial distance d_1 measuring from about 0.0010 to about 0.0020 inch (0.0025 to 0.0051 cm) from the cutting edge 22D. The raised elements 26D may all be formed in the same manner or may be different from one another. The raised elements 26D may also subtend

different angles, be of different heights, have different radial lengths, or have a different spacing (including zero) from the cutting edge without departing from various aspects of the present invention.

[0060] Referring to FIGS. 14 and 15, the radial length RL of the leading radial wall 30D of each raised element 26D is defined by the radial distance between the radially outermost portion P1 and the radially innermost portion P2 of the leading radial wall. In FIG. 15, the radial length RL of the radial wall 30D is measured using concentric, outer and inner imaginary circles C1, C2, respectively, each having a center that is coincident with the longitudinal axis LA. The radially outermost portion P1 of the leading radial wall 30D lies on the circumference of the outer imaginary circle C1, and the radially innermost portion P2 lies on the circumference of the inner imaginary circle C2. In the illustrated embodiment, each radially outermost portion P1 of the leading radial walls 30D lies on the circumference of the same outer imaginary circle C1, and each radially innermost portion P2 lies on the circumference of the same inner imaginary circle C2, though it is understood that the radially outermost and innermost portions, respectively, may not lie on the same imaginary circles without departing from the scope of the present invention. In the illustrated embodiment, the radially inner end wall 34D is arcuately shaped so that substantially the entire radially inner end wall lies on the circumference of the inner imaginary circle C2, although this may not be the case in other embodiments. The radial distance between the circumferences of the outer and inner imaginary circles C1, C2, respectively, determines the radial length RL of the leading radial wall 30D, as shown in FIG. 15. In one example, the radial length RL of the leading radial wall 30D may measure from about 0.0050 in to about 0.0200 in, or from about 0.0075 in to about 0.0175 in, or from about 0.0100 in to about 0.0150 in. In one example, the radial length RL of the leading radial wall may be at least about 33%, or at least about 40%, or at least about 50%, or at least about 60% or at least about 70% or at least about 80% of the radius R (FIG. 15) of the cutting edge 22D.

[0061] Referring still to FIG. 15, the radially innermost portion P2 of the leading radial wall 30D of each raised element 26D is spaced a radial distance d_2 from the longitudinal axis LA of the cutting element 4D. As set forth above, the radially innermost portion P2 of the leading radial wall 30D lies on the circumference of the inner imaginary circle C2. The radial distance between the longitudinal axis LA and the circumference of the inner imaginary circle C2 determines the radial distance d_2 between the longitudinal axis and the radially innermost portion

P2 of the leading radial wall 30D. In one example, radial distance d between the longitudinal axis and the radially innermost portion P2 of the leading radial wall 30D may measure from about 0.0150 in to about 0.0300 in, or from about 0.0175 in to about 0.0275 in, or from about 0.0200 in to about 0.0250 in. In one example, the radial distance d_2 may be less than about 66%, or less than about 60%, or less than about 55%, or less than about 50%, or less than about 45%, or less than about 40%, or less than about 35% of the radius R of the annular cutting edge 22D, as shown in FIG. 15. In one example, the radial distance d_2 may be from about 15% to about 66%, or from about 20% to about 60%, or from about 25% to about 50%, or from about 30% to about 40% of the radius R of the annular cutting edge 22D.

[0062] As disclosed above herein, in the deployed configuration the cutting element 4D extends through the window or opening 6 in the tip 18. In this embodiment, each raised element 26D is configured such that as the cutting element 4D is rotated 360 degrees, less than an entirety of the leading radial wall 30D is ever exposed through the opening 6. Stated another way, a radially outer portion of each raised element 26D is cyclically exposed through the opening 6 while a radial inner portion of the leading radial wall never passes through the opening (i.e., is never exposed). This feature is shown in FIG. 17, where the circle indicated by reference character S defines an outer surface of the tip 18 that is immediately adjacent the window 6 (see also, FIG. 16). As can be seen from FIG. 17, an imaginary line L is drawn to show the location where a radial portion of the cutting element 4D is at its maximum exposure outside the catheter body. However, as can be seen from this figure, a radial inner portion of the leading radial wall 30D of cutting element 26D at the imaginary line L does not cross the exposure plane EP and does not pass through the window 6.

[0063] The cutter 4D is rotated in the direction of arrow R and pushed distally to force cup-shaped surface 24D and raised elements 26D into contact with material such as atheroma or plaque. Raised elements 26D will tend to concentrate cutting force along edge 50D because of the negative rake angle of the leading radial wall 30D. Cutter 4D will tend to scrape away material such as atheroma or plaque rather than cut into this material due to the obtuse included angle between wall 30D and distal wall 38D, in the vicinity of edge 50D. Material contacted by raised elements 26D will tend to be directed toward axis LA by surface 30D which curves from a more circumferential extent near edge 22D to a more radial extent near edge 34D. Moreover, it is believed that configuring the raised element(s) 26D so that only a portion of the leading radial

wall 30D intermittently passes through the window 6 (i.e., only a portion and not the entirety of the leading radial wall is exposed) and is intermittently exposed (as explained above), facilitates cutting and/or breaking of hardened tissue (e.g., calcified tissue) by ensuring that the raised elements 26D engage tissue that may enter the window 6, as shown in FIG. 18. The leading radial wall 30D also more reliably guides or directs removed material toward the axis LA.

[0064] The cutting element 4D may be formed in a suitable manner such as integrally as a single, one-piece construction. For example, the cutting element 4D may be comprised of steel, tungsten carbide, tungsten carbide cobalt, tungsten carbide molybdenum, silicon carbide, silicon nitride, ceramic, amorphous metals or other materials and may be manufactured by methods including turning, grinding, sintering, electro-discharge machining (EDM), laser cutting, heat treating, precipitation hardening, casting or other methods.

[0065] Referring to FIGS. 19 and 20, cutting elements 4E and 4F are shown (respectively). Cutting element 4E and 4F include raised elements 26E, 26F, that may be identical to the raised elements 26A-26D of any of the previously disclosed cutting element 4A-4D disclosed above or have a different configuration. Accordingly, the teachings of the raised elements 26A-26D set forth above are incorporated in this embodiment. As opposed to the previously disclosed cutting elements, the cutting elements 4E and 4F each has an abrasive cup-shaped surface 24E, 24F. In one embodiment, other than the abrasive cup-shaped surface 24E, 24F, the cutting elements 4E and 4F are identical to the cutting element 4D, including the raised elements 26E being identical to the raised elements 26D. Accordingly, in this embodiment each of the cutting elements 4E and 4F includes the cutting element 4D and the respective one of the abrasive cup-shaped surfaces 24E, 24F. Referring to FIG. 19, cutting element 4E includes the embossed area of the cup-shaped surface 24E, including raised, diamond-shaped abrading members 100. Referring to FIG. 20, cutting element 4F includes a dimpled area of the cup shape surface 24F including depressed portions 102. In each embodiment, the abrasive cup-shaped surface 24E, 24F abrades hardened tissue (e.g., calcified tissue), and in particular, the abrasive cup-shaped surface abrades hardened tissue that is not engaged by the raised elements 26E. Thus, it is believed that the cutting elements 4E and 4F may more effectively remove hardened tissue compared to the cutting element 4, which is free from an abrading surface.

[0066] The cutting elements 4E and 4F each may be formed integrally as a single, one-piece construction, or may be formed as a multiple-piece construction. As an example, each

cutting element 4E and 4F may be comprised of steel, tungsten carbide, tungsten carbide cobalt, tungsten carbide molybdenum, silicon carbide, silicon nitride, ceramic, amorphous metals or other materials and may be manufactured by methods including turning, grinding, sintering, electro-discharge machining (EDM), laser cutting, heat treating, precipitation hardening, casting or other methods.

[0067] Referring to FIGS. 21-25, another embodiment of a cutting element is indicated generally at 4G. The cutting element 4G is similar to the cutting element 4B, and therefore, like components are indicated by similar reference numerals, and the teachings set forth with respect to the cutting element 4B apply equally to this embodiment. Briefly, each raised element 26G of the cutting element 4G has a leading wall 30G, a radial inner end wall 34G, a distal wall 38G, and a leading edge 50G. For purposes of this disclosure, the main difference between the present cutting element 4G and the prior cutting element 4B is that the radial distance between the leading edge 50G of each raised element 26G and the cutting edge 22G of the present cutting element 4G is greater than the radial distance between the leading edge 50B of each raised element 26B and the cutting edge 22B of the cutting element 4B. It is understood that the teachings set forth herein for the cutting element 4G apply equally to the other cutting elements 4A-4F.

[0068] In the illustrated example, the present cutting element 4G includes an undercut (e.g., groove, recess, notch or cutout) 106 in each of the raised elements 26G adjacent the cutting edge 22G. The undercut 106 extends through the leading wall 30G, the leading edge 50G, and the distal wall 38G of each raised element 26G. The undercut 106 extends generally radially into the raised element 26G at the radially outermost portion of the raised element. As best seen in Fig. 24, the undercut 106 has a circumferential extent almost perpendicular to the wall 30G. The depth of the undercut 106 shallows slightly circumferentially away from the leading edge 50G. In contrast, the undercut 41C of Figs. 11 and 11A extends circumferentially into the raised element 26C and has a generally radial extent along the wall 30C. As shown best in FIG. 25, because of the undercut 106, the radially outermost portion P1 of the leading edge 50G of the cutting element 4G is radially spaced from the chamfered circumferential inner surface 25G (broadly, the inner surface) of the cutting element a radial distance D1 (Fig. 25). In one example, the radial distance D1 may measure from greater than 0.0000 in to about 0.0100 in, or from greater than 0.0000 to about 0.0050 in, or from about 0.0005 in to about 0.0015 in. The

radially outermost portion P1 of the leading edge 50G is radially spaced from the cutting edge 22G of the cutting element 4G a distance D2, which is greater than the radial distance between the leading edge 50B and the cutting edge 22B of the cutting element 4B. In one example, the distance D2 may measure from greater than 0.0000 in to about 0.0100 in, or from greater than 0.0000 to about 0.0050 in, or from about 0.0005 in to about 0.0020 in. Moreover, the leading edge 50G of the cutting element 4G may be spaced a minimum longitudinal distance D3 from the cutting edge 22G. In one example, the distance D3 may measure from about 0.0000 to about 0.0020 in. In one example, the leading edge 50G is similar to the leading edge 50B, except for the undercut 106, and therefore, an imaginary extrapolated line extending from the leading edge 50G intersects the chamfered inner surface 25G of the cutting element 4G at portion P3 (FIG. 24), which may be substantially the same location as the radially outermost portion P1 of the raised element 26B (see, e.g., FIG. 14).

[0069] It is believed that by spacing the leading edges 50G of the raised elements 26G from the chamfered inner circumferential portion 25G of the cutting element 4G, while maintaining a suitable minimum longitudinal distance between the cutting edge 22G and the leading edges of the raised elements, the raised elements 26G have better engagement with tissue than the cutting element 4B, without sacrificing cutting efficiency of the cutting element.

[0070] The cutting elements 4G may be formed integrally as a single, one-piece construction, or may be formed as a multiple-piece construction. As an example, the cutting element 4G may be comprised of steel, tungsten carbide, tungsten carbide cobalt, tungsten carbide molybdenum, silicon carbide, silicon nitride, ceramic, amorphous metals or other materials and may be manufactured by methods including turning, grinding, sintering, electro-discharge machining (EDM), laser cutting, heat treating, precipitation hardening, casting or other methods.

[0071] Use of the catheter 2 is now described in connection with the cutting element 4 but is equally applicable to use of the catheter 2 with either the cutting element 4A, the cutting element 4B, or the cutting element 4C. The catheter 2 is introduced into the patient in a conventional manner using a guidewire (not shown) or the like. The catheter 2 is advanced with the cutting element in the stored position of FIG. 2 until the catheter is positioned proximal to the location where material is to be removed. The cutting element 4 is then moved proximally so that the ramp 16 and cam surface 14 engage to move the cutting element 4 to the cutting position of

FIG. 3 and to deflect the tip of the catheter 2 to move the cutting element 4 toward the tissue to be cut. The cutting element 4 is rotated about longitudinal axis LA and catheter 2 is then moved distally through the vessel so that the cutting element 4 cuts tissue. The tissue, which has been cut, is directed into the tissue chamber 12 by the cup-shaped surface 24, one or more raised elements 26, by curved surface 30B (of cutting element 4B), or by any combination of a cup-shaped surface, raised element, or curved surface. The location for collection of cut tissue may be other than described within the scope of the present invention.

[0072] More specifically, when using cutting element 4B and rotating the cutting element in the direction of arrow R (FIG. 9) cutting edge 22B slices softer material and cup-shaped surface directs the cut material into tissue chamber 12; the relief angle assures that distally directed force on the catheter is concentrated at raised element edge 50B rather than distributed over wall 38B; raised elements 26B will tend to scrape away or pulverize harder material such as calcium due to the obtuse included angle between leading radial wall 30B and distal wall 38B in the vicinity of edge 50B; curved surface 30B directs material particles towards cutter axis LA; and curved surface 30B when rotating creates a fluid vortex that tends to direct material particles towards cutter axis LA and distally into tissue chamber 12.

[0073] More specifically, when using an undercut such as that shown for cutting element 4C and rotating the cutting element in the direction of arrow T (FIG. 11) undercut 41C directs material away from cutting edge 22A, along cup-shaped surface towards axis LA, and radially towards axis LA of the cutting element.

[0074] More specifically, when using the cutting element 4D with raised elements 26D having leading radial walls 30D as set forth above, the raised elements facilitate cutting and/or breaking of hardened tissue (e.g., calcified tissue) by ensuring that the raised elements 26D engage tissue that may enter the window 6, as shown in FIG. 18.

[0075] When using the cutting elements 4E or 4F, the abrasive cup-shaped surface 24E, 24F abrades hardened tissue (e.g., calcified tissue), and in particular, the abrasive cup-shaped surface abrades hardened tissue that is not engaged by the raised elements 26E.

[0076] When using the cutting element 4G, the raised elements 26G have improved engagement with tissue, as compared to the cutting element 4B, without sacrificing cutting efficiency of the cutting element.

[0077] Having described the invention in detail, it will be apparent that modifications and variations are possible without departing from the scope of the invention defined in the appended claims.

[0078] When introducing elements of the present invention or the preferred embodiments(s) thereof, the articles "a", "an", "the" and "said" are intended to mean that there are one or more of the elements. The terms "comprising", "including" and "having" are intended to be inclusive and mean that there may be additional elements other than the listed elements.

[0079] As various changes could be made in the above constructions, products, and methods without departing from the scope of the invention, it is intended that all matter contained in the above description and shown in the accompanying drawings shall be interpreted as illustrative and not in a limiting sense.

WHAT IS CLAIMED IS:

1. A tissue-removing catheter comprising:
 - an elongate catheter body having opposite distal and proximal portions and being sized and shaped for introduction into a body lumen of a subject, the catheter body having a window at the distal portion thereof;
 - a drive shaft extending longitudinally within the catheter body, wherein the drive shaft is rotatable relative to the catheter body about a longitudinal axis of the drive shaft;
 - a cutting element at the distal portion of the elongate catheter body adjacent the window, the cutting element having opposite proximal and distal ends and a longitudinal axis extending therebetween, the cutting element being operatively connected to the drive shaft for rotation about the longitudinal axis of the cutting element, the cutting element including
 - an annular cutting edge at the distal end of the cutting element surrounding the longitudinal axis of the cutting element, the annular cutting edge having a radius as taken from the longitudinal axis of the cutting element,
 - an inner surface extending proximally from the cutting edge and defining an internal cavity,
 - at least one raised element in the internal cavity having a leading radial wall extending generally radially inward toward the longitudinal axis of the cutting element,
 - wherein the cutting element is extendable through the window during operation such that as the cutting element is being rotated about its longitudinal axis, less than an entire radial portion of the leading radial wall passes through the window.

2. The tissue-removing catheter set forth in claim 1, wherein the leading radial wall has a radially outermost portion relative to the longitudinal axis of the cutting element, a radially innermost portion relative to the longitudinal axis of the cutting element, and a radial length extending between the radially outermost and innermost portions, wherein the radially innermost portion of the leading radial wall is spaced a radial distance from the longitudinal axis that is less than about 66% of the radius of the annular cutting edge.

3. The tissue-removing catheter set forth in claim 2, wherein said radial distance is from about 15% to less than 66% of the radius of the annular cutting edge.

4. The tissue-removing catheter set forth in claim 3, wherein said radial distance is from about 20% to about 60% of the radius of the annular cutting edge.

5. The tissue-removing catheter set forth in claim 4, wherein said radial distance is from about 30% to about 40% of the radius of the annular cutting edge.

6. The tissue-removing catheter set forth in claim 2, wherein the radial length of the leading radial wall is at least about 33% of the radius of the annular cutting edge.

7. The tissue-removing catheter set forth in claim 1, wherein the radially outermost portion is spaced apart radially from the inner surface of the cutting element.

8. The tissue-removing catheter set forth in claim 7, wherein the radially outermost portion is spaced a radial distance from greater than 0.0000 in (0.0000 mm) to about 0.0100 in (0.254 mm) from the inner surface of the cutting element.

9. The tissue-removing catheter set forth in claim 7, wherein the cutting element includes an undercut extending generally radially into the raised element such that the radially outermost portion is spaced apart radially from the inner surface of the cutting element.

10. The tissue-removing catheter set forth in claim 1, wherein the at least one raised element comprises a plurality of raised elements.

11. The tissue-removing catheter set forth in claim 1, wherein at least a central portion of the inner surface is generally cup-shaped.

12. The tissue-removing catheter set forth in claim 11, wherein central portion of the inner surface comprises an abrasive area adapted to abrade hardened tissue as the cutting element is rotating about its longitudinal axis.

13. The tissue-removing catheter set forth in claim 12, wherein the abrasive area comprises raised, diamond-shaped abrading members.

14. The tissue-removing catheter set forth in claim 12, wherein the abrasive area comprises a dimpled area including depressed portions.

15. A tissue-removing catheter comprising:
an elongate catheter body having opposite distal and proximal portions and being sized and shaped for introduction into a body lumen of a subject;
a drive shaft extending longitudinally within the catheter body, wherein the drive shaft is rotatable relative to the catheter body about a longitudinal axis of the drive shaft;
a cutting element at the distal portion of the elongate catheter body, the cutting element having opposite proximal and distal ends and a longitudinal axis extending therebetween, the cutting element being operatively connected to the drive shaft for rotation about a longitudinal axis of the cutting element, the cutting element including
an annular cutting edge at the distal end of the cutting element surrounding the longitudinal axis of the cutting element, the annular cutting edge having a radius as taken from the longitudinal axis of the cutting element,
an inner surface extending proximally from the cutting edge and defining an internal cavity,
at least one raised element in the internal cavity extending generally longitudinally outward from the inner surface, the at least one raised element including a leading radial wall extending generally radially inward toward the longitudinal axis of the cutting element, the leading radial wall having a radially outermost portion relative to the longitudinal axis of the cutting element, a radially innermost portion relative to the longitudinal axis of the cutting element, and a radial length extending between the radially outermost and innermost

portions, wherein the radially outermost portion is spaced apart radially from the inner surface of the cutting element.

16. The tissue-removing catheter set forth in claim 15, wherein the radially outermost portion is spaced a radial distance from greater than 0.0000 in (0.0000 mm) to about 0.0100 in (0.2540 mm) from the inner surface of the cutting element.

17. The tissue-removing catheter set forth in claim 15, wherein the cutting element includes an undercut extending generally radially into the raised element such that the radially outermost portion is spaced apart radially from the inner surface of the cutting element.

18. A tissue-removing catheter comprising:

an elongate catheter body having opposite distal and proximal portions and being sized and shaped for introduction into a body lumen of a subject;

a drive shaft extending longitudinally within the catheter body, wherein the drive shaft is rotatable relative to the catheter body about a longitudinal axis of the drive shaft;

a cutting element at the distal portion of the elongate catheter body, the cutting element having opposite proximal and distal ends and a longitudinal axis extending therebetween, the cutting element being operatively connected to the drive shaft for rotation about a longitudinal axis of the cutting element, the cutting element including

an annular cutting edge at the distal end of the cutting element surrounding the longitudinal axis of the cutting element, the annular cutting edge having a radius as taken from the longitudinal axis of the cutting element,

an inner surface extending proximally from the cutting edge and defining an internal cavity,

at least one raised element in the internal cavity extending generally longitudinally outward from the inner surface, the at least one raised element including a leading radial wall extending generally radially inward toward the longitudinal axis of the cutting element, the leading radial wall having a radially outermost portion relative to the longitudinal axis of the cutting element, a radially innermost portion relative to the longitudinal axis of the

cutting element, and a radial length extending between the radially outermost and innermost portions,

wherein the radially innermost portion of the leading radial wall is spaced a radial distance from the longitudinal axis that is less than about 66% of the radius of the annular cutting edge.

19. The tissue-removing catheter set forth in claim 18, wherein said radial distance is from about 15% to less than 66% of the radius of the annular cutting edge.

20. The tissue-removing catheter set forth in claim 19, wherein said radial distance is from about 20% to about 60% of the radius of the annular cutting edge.

21. The tissue-removing catheter set forth in claim 20, wherein said radial distance is from about 30% to about 40% of the radius of the annular cutting edge.

22. The tissue-removing catheter set forth in claim 18, wherein the radial length of the leading radial wall is at least about 33% of the radius of the annular cutting edge.

23. The tissue-removing catheter set forth in claim 18, wherein the radially outermost portion is spaced apart radially from the inner surface of the cutting element.

24. The tissue-removing catheter set forth in claim 18, wherein the at least one raised element comprises a plurality of raised elements.

25. The tissue-removing catheter set forth in claim 18, wherein at least a central portion of the inner surface is generally cup-shaped, the tissue-removing catheter further comprising a plurality of abrading members formed on at least the central portion of the inner surface, wherein the abrading members are adapted to abrade hardened tissue as the cutting element is rotating about its longitudinal axis.

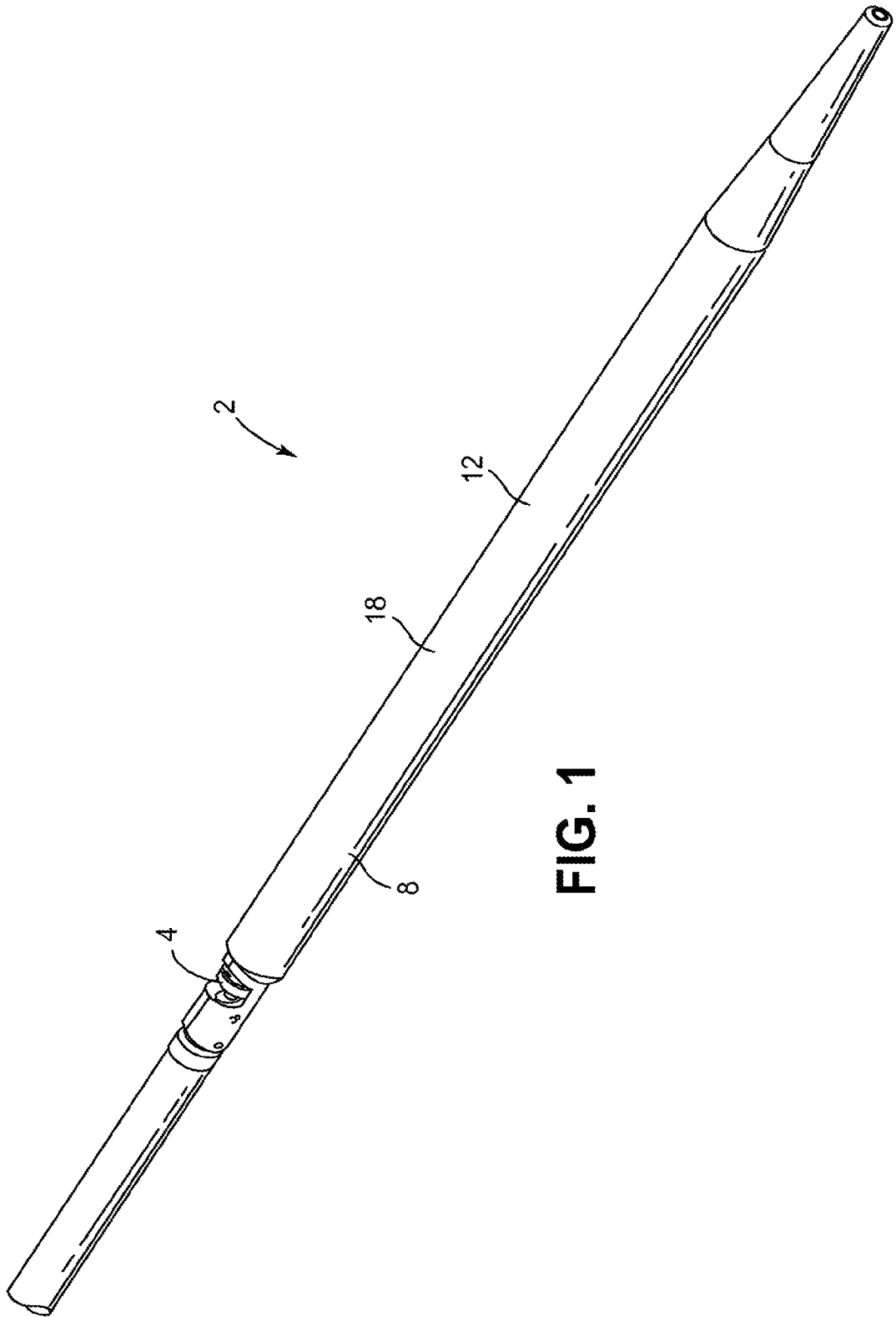

FIG. 1

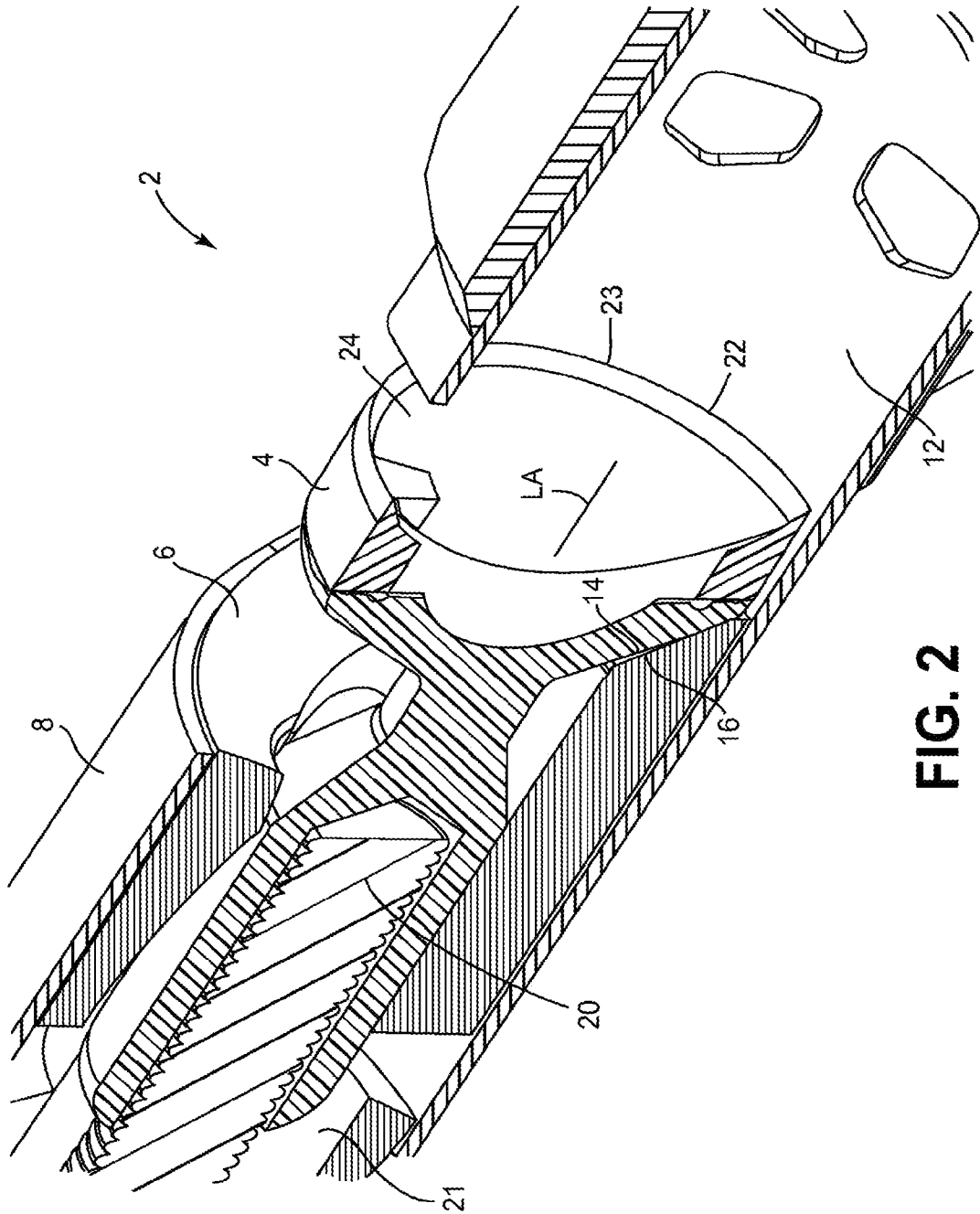

FIG. 2

3/25

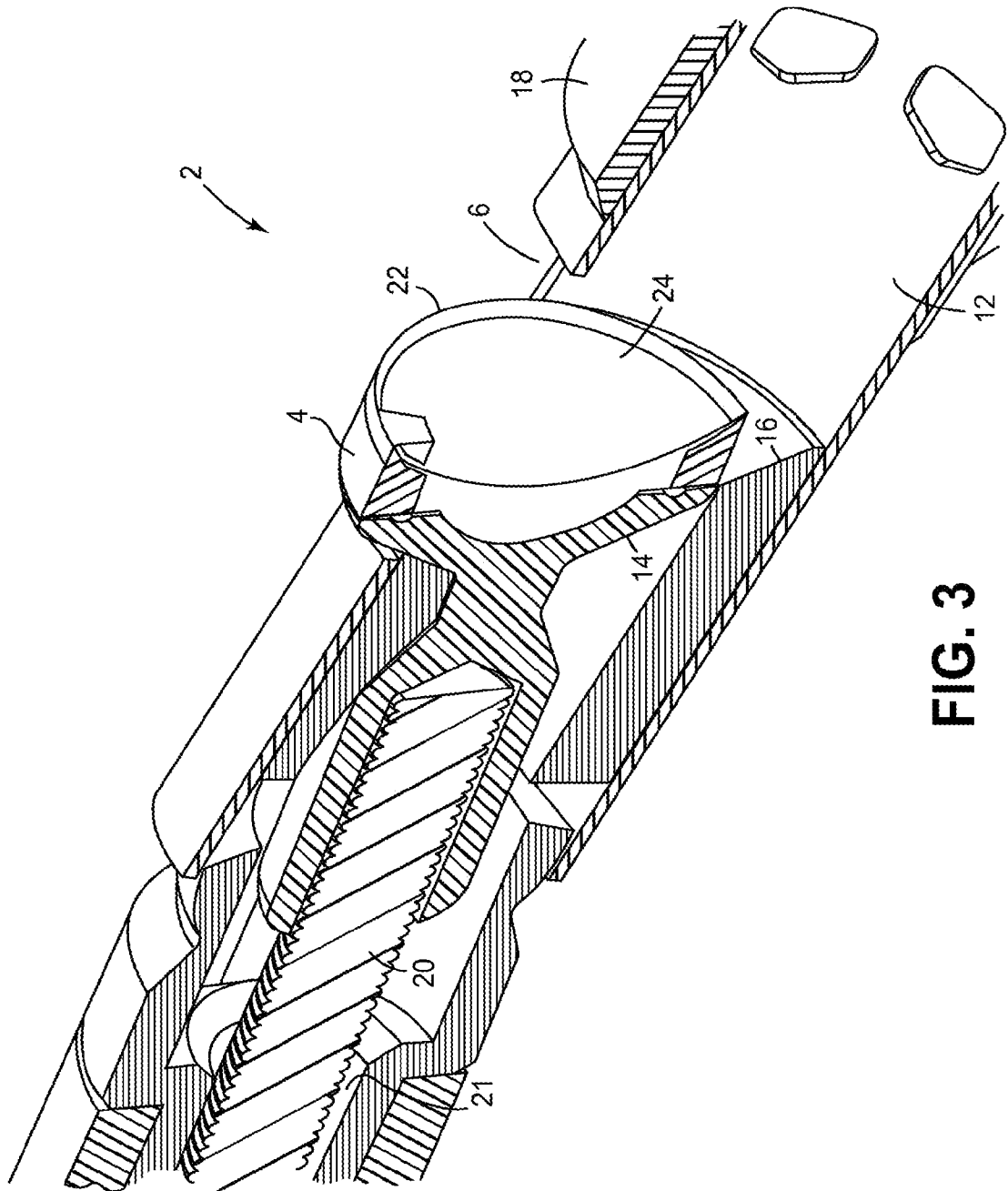

FIG. 3

4/25

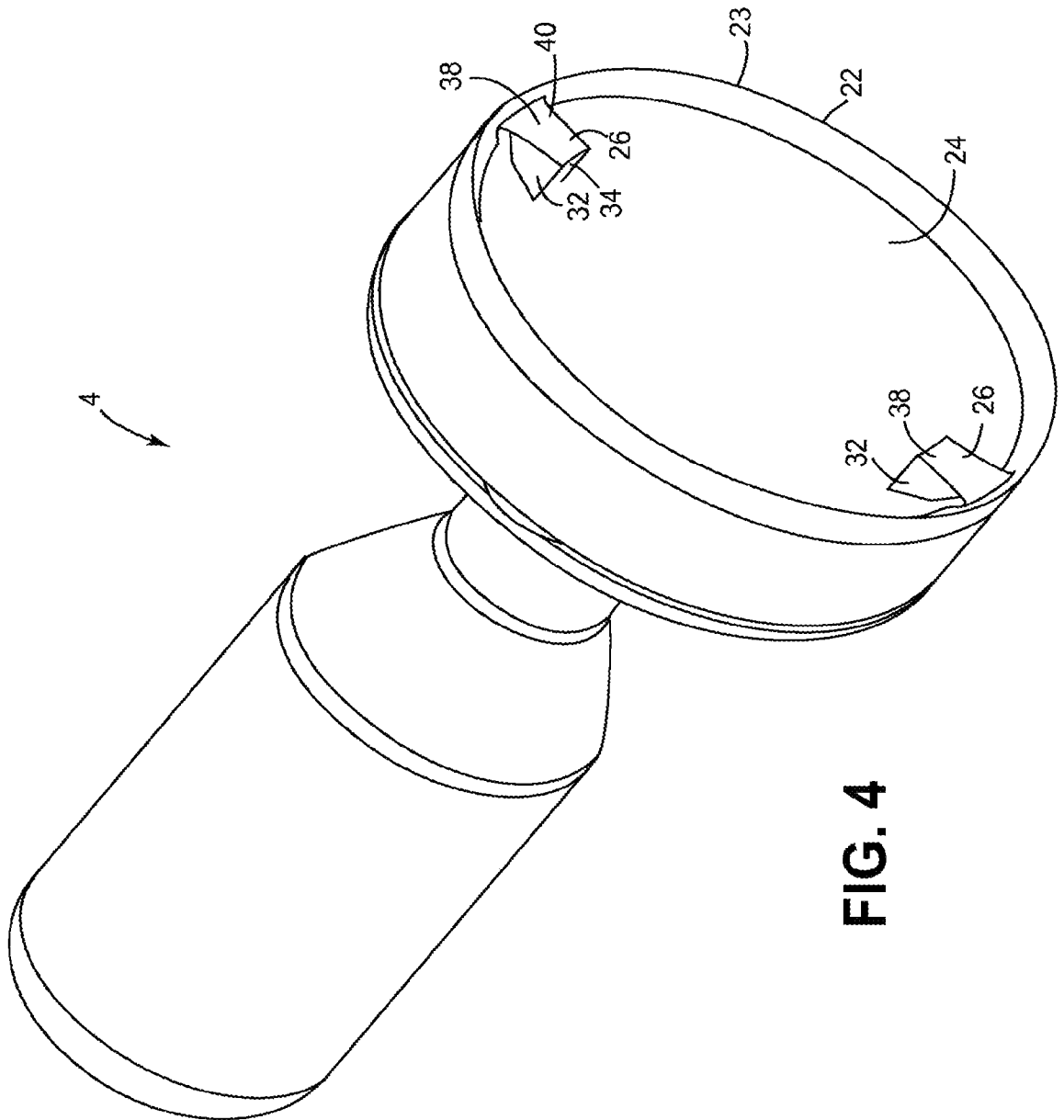

FIG. 4

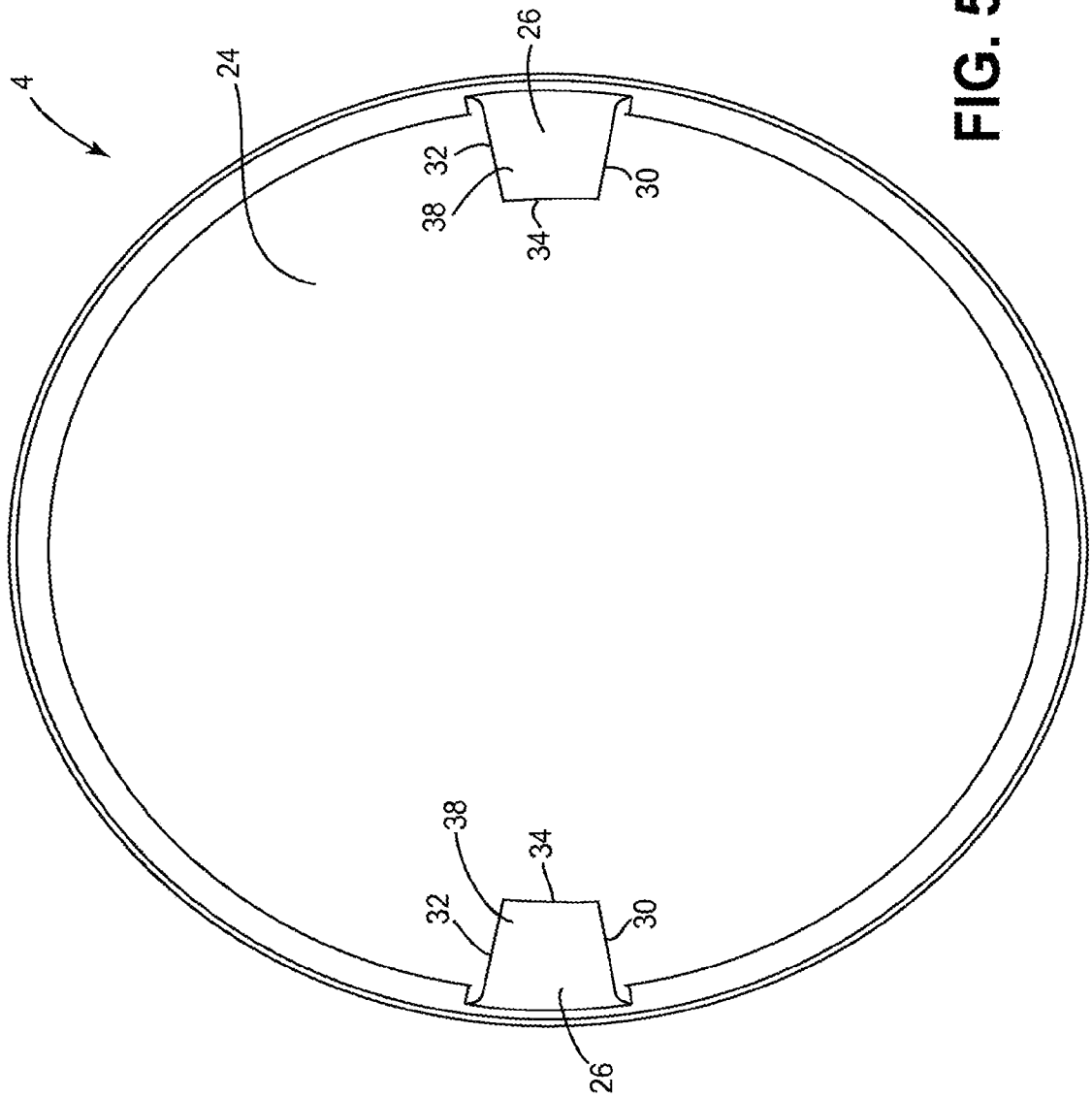
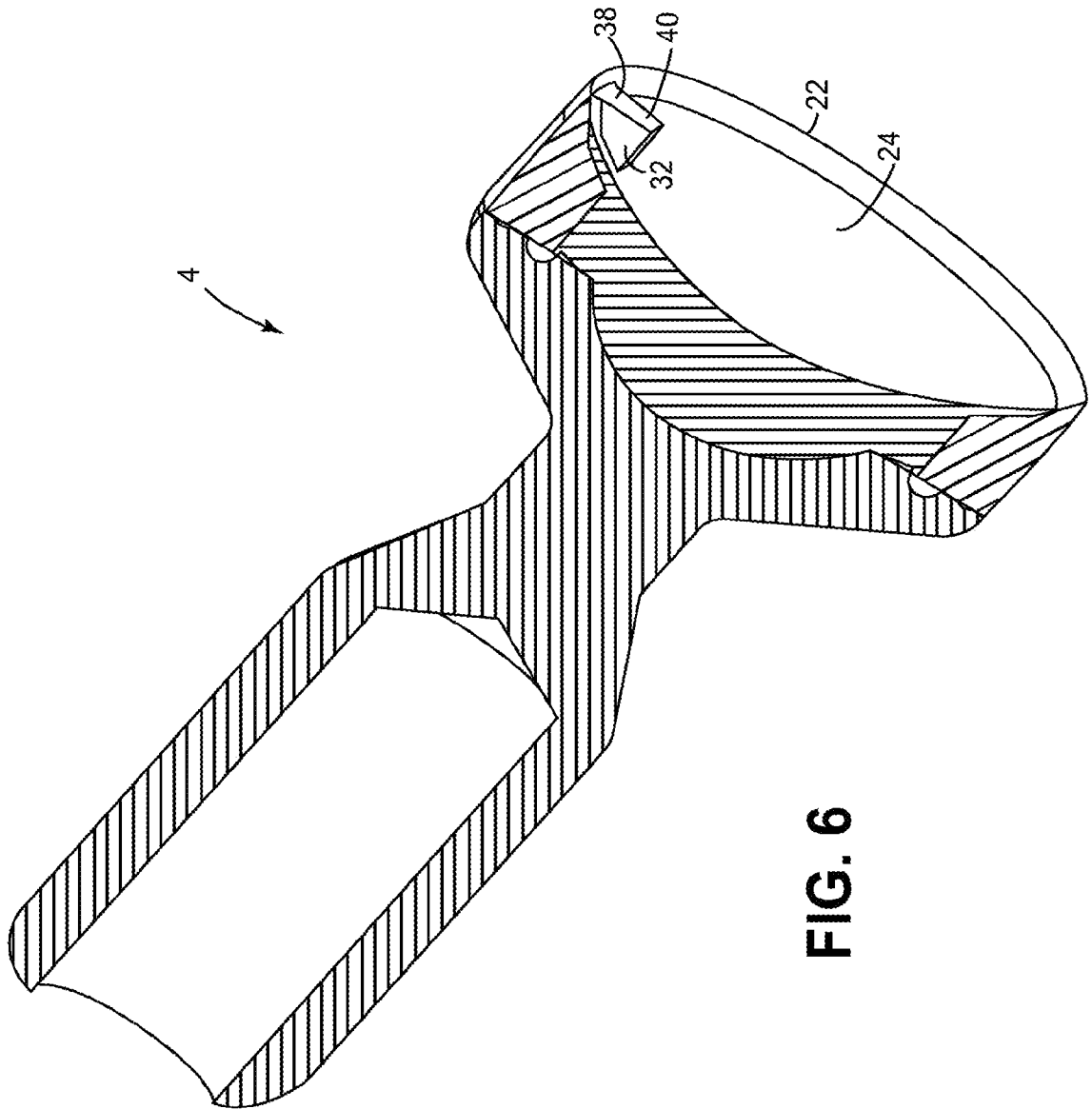

FIG. 5

6/25



7/25

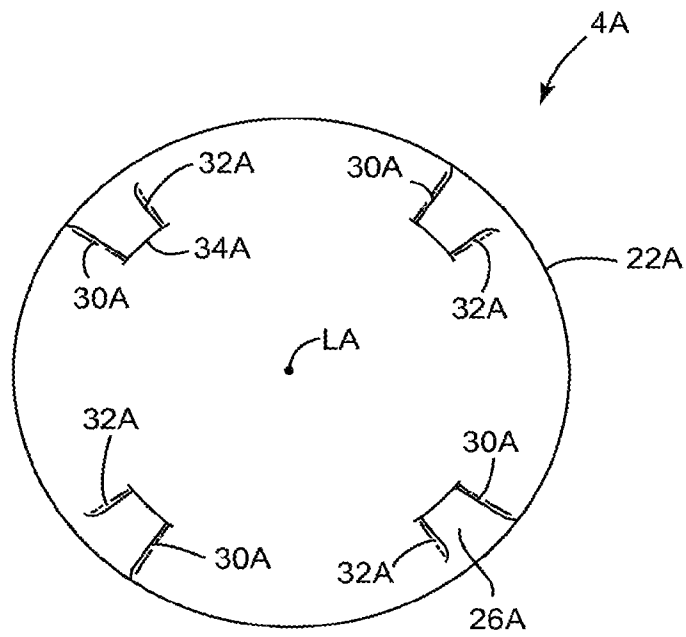

FIG. 7

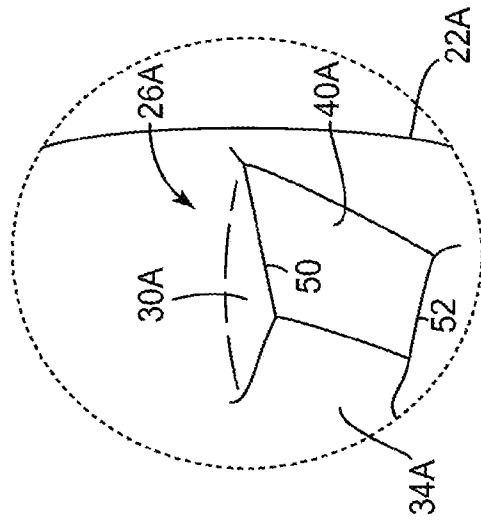

FIG. 8A

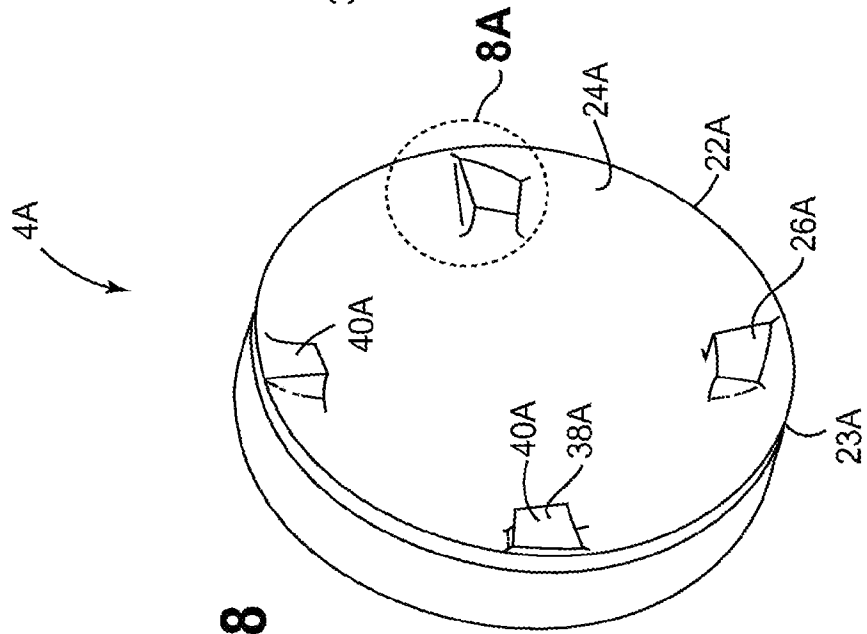

FIG. 8

9/25

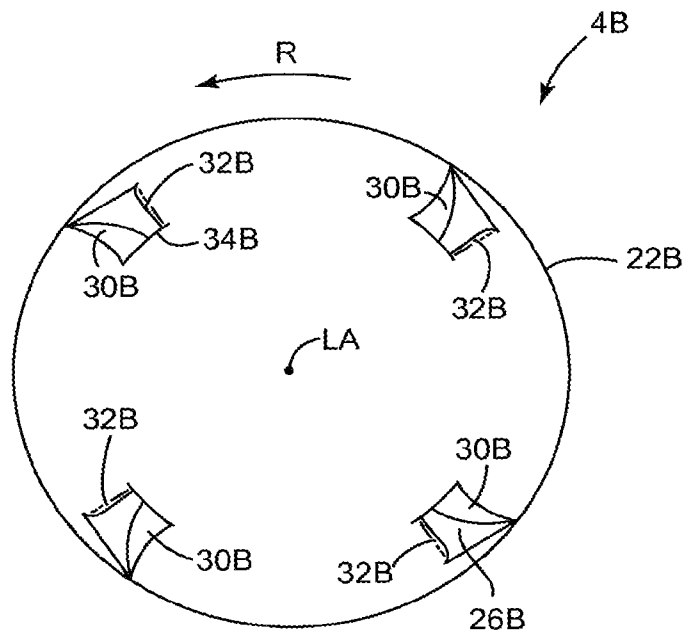

FIG. 9

10/25

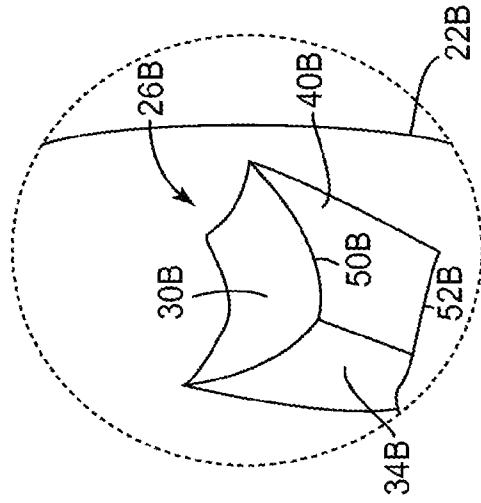

FIG. 10A

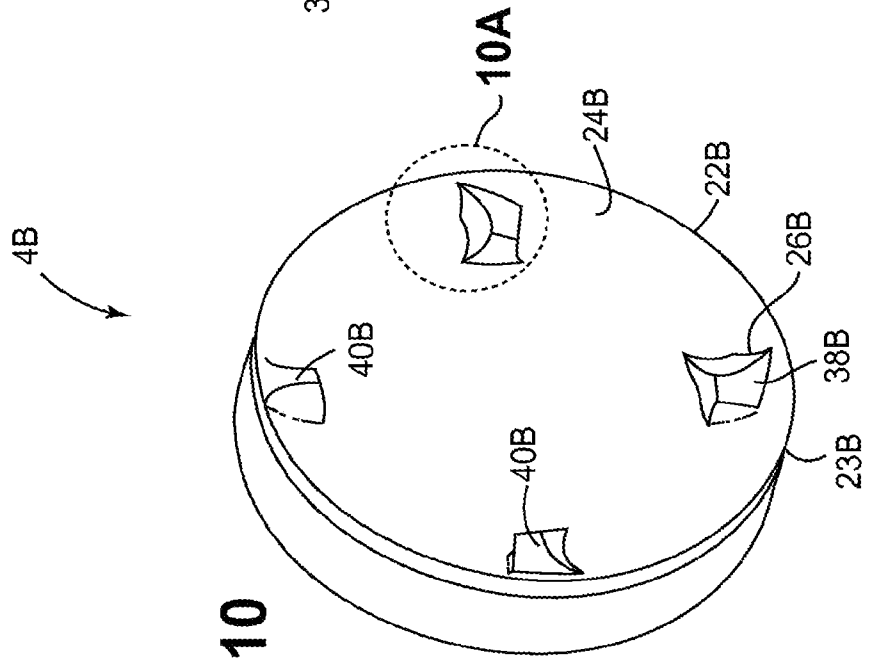

FIG. 10

11/25

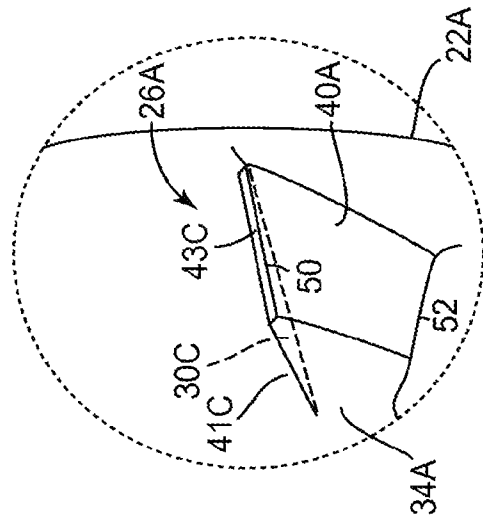

FIG. 11A

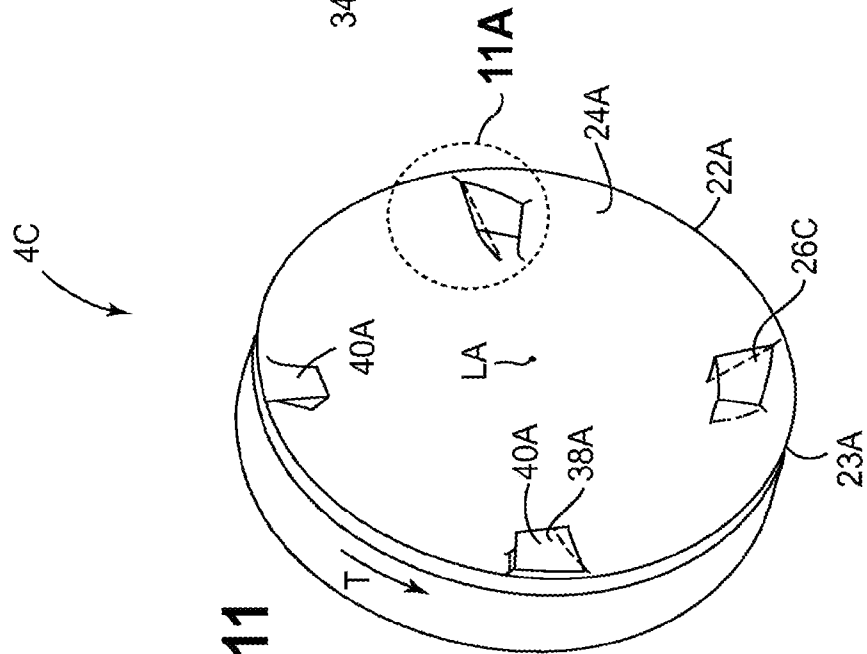

FIG. 11

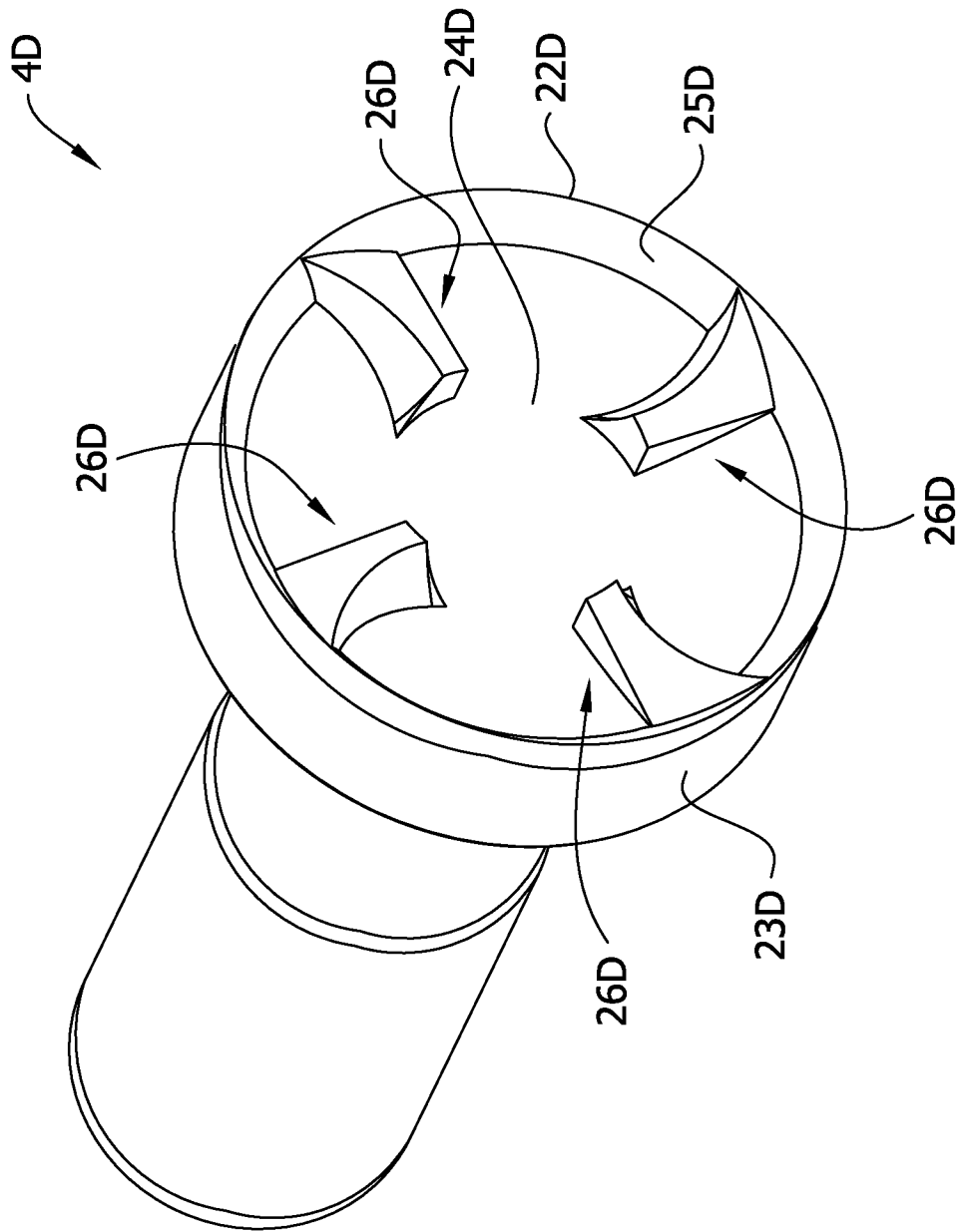

FIG. 12

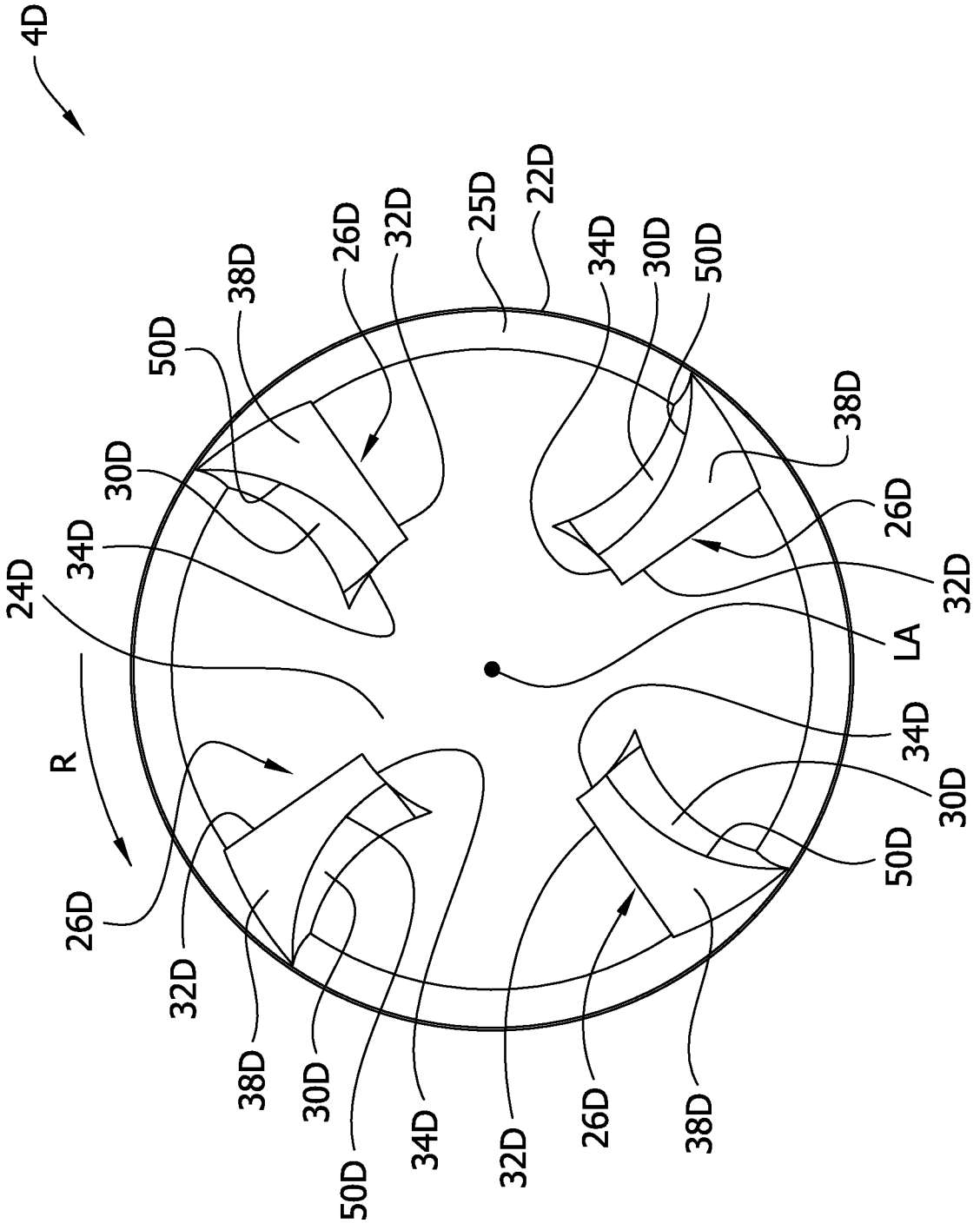

FIG. 13

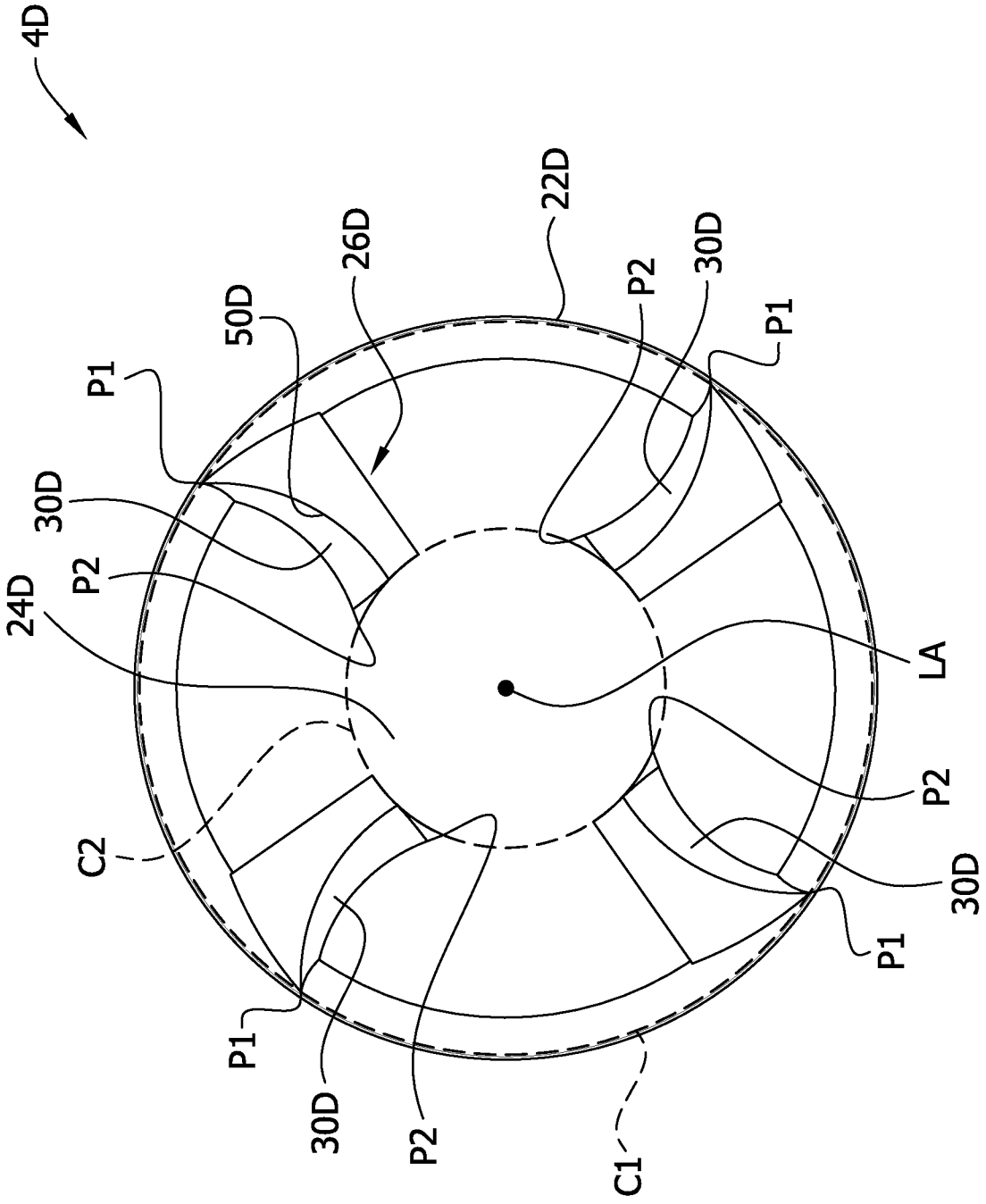

FIG. 14

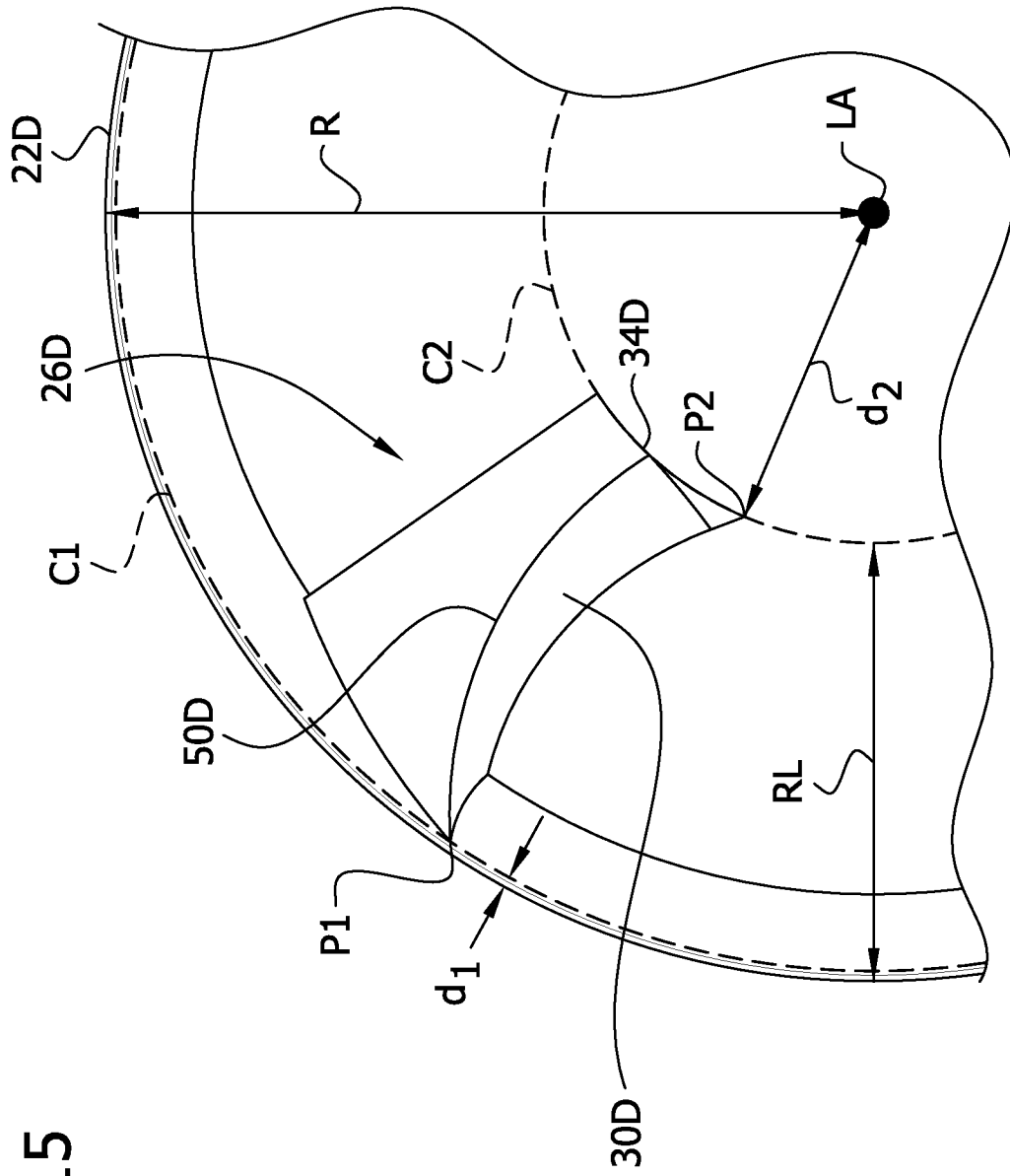

FIG. 15

FIG. 16

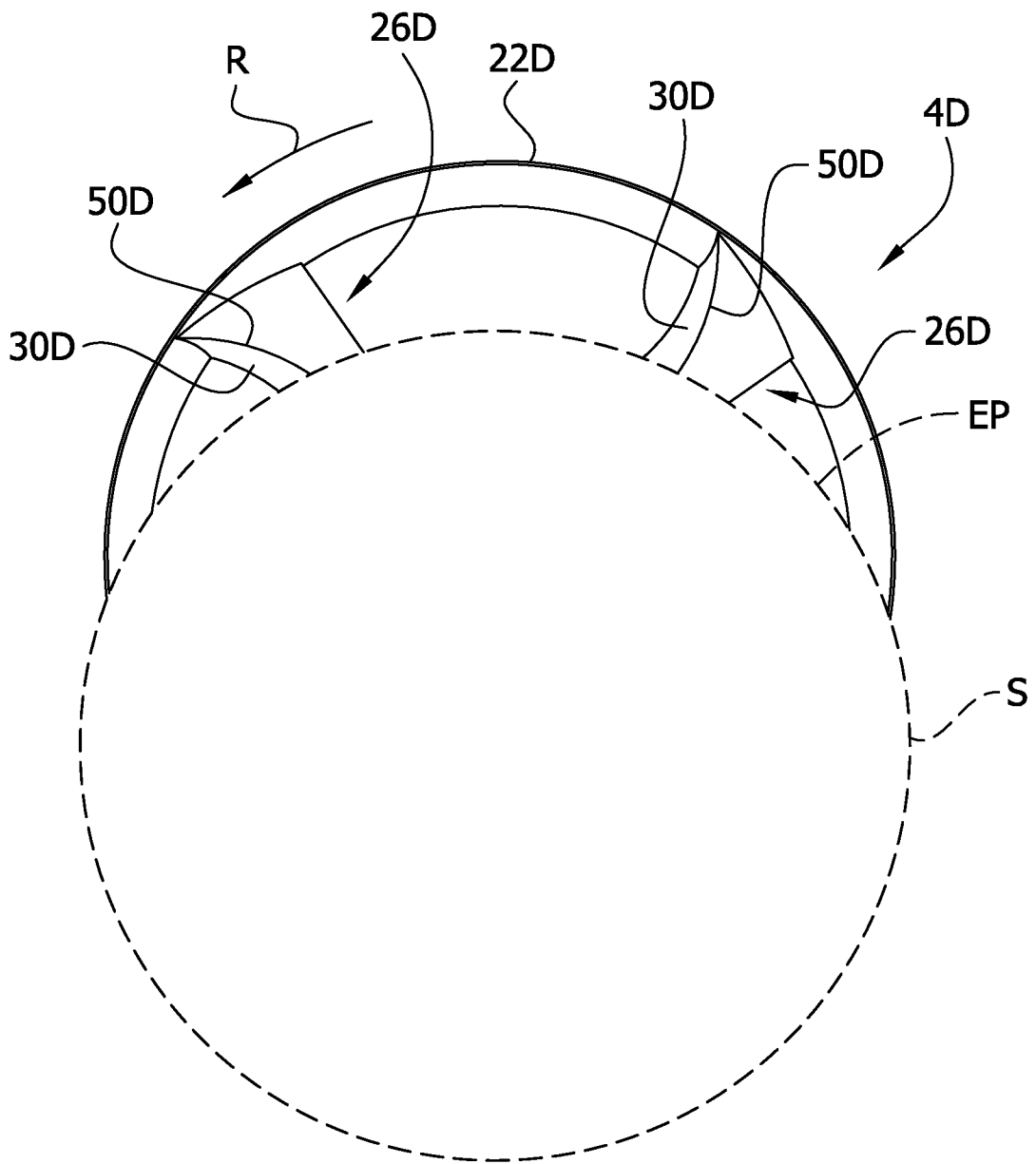

FIG. 17

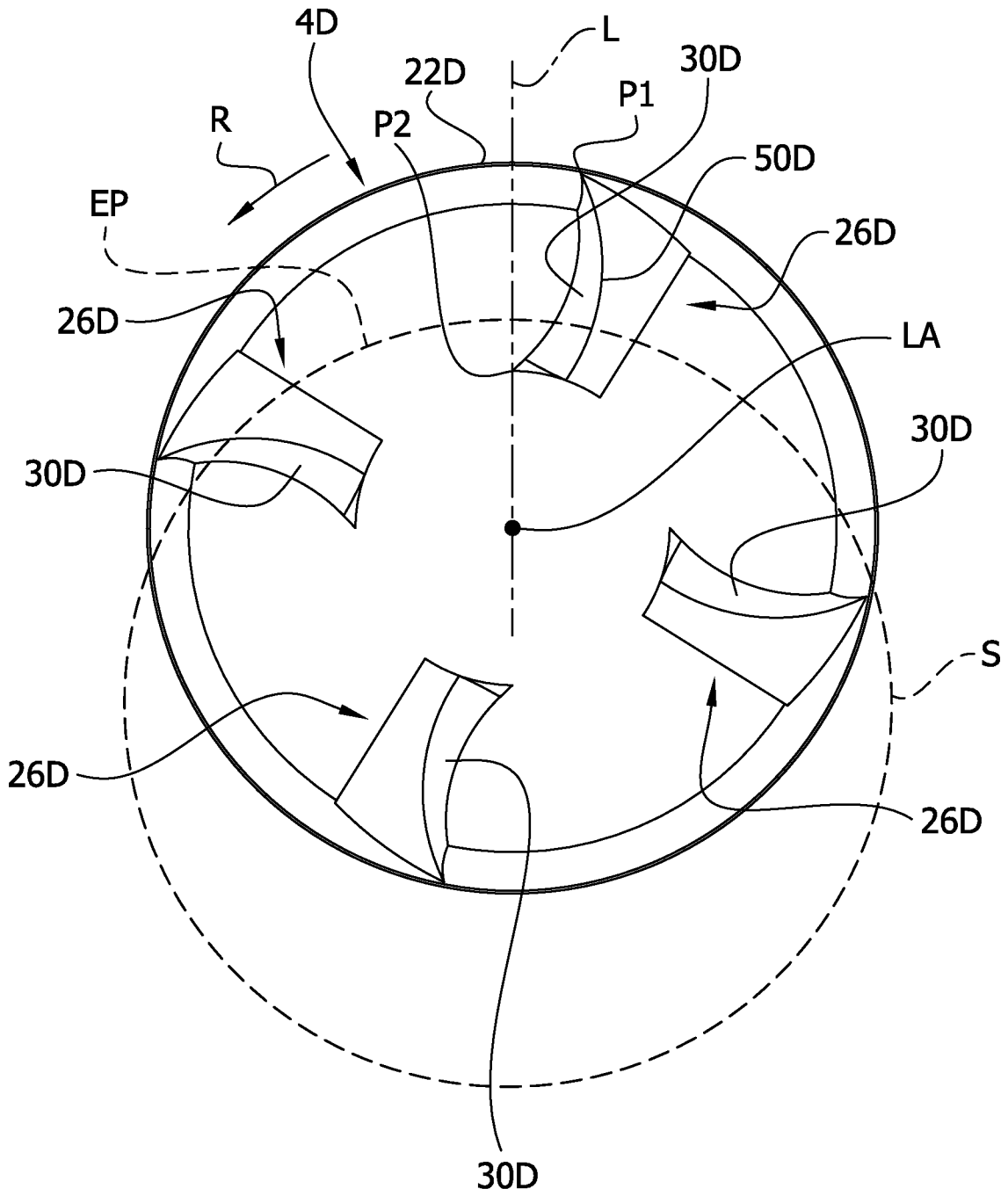
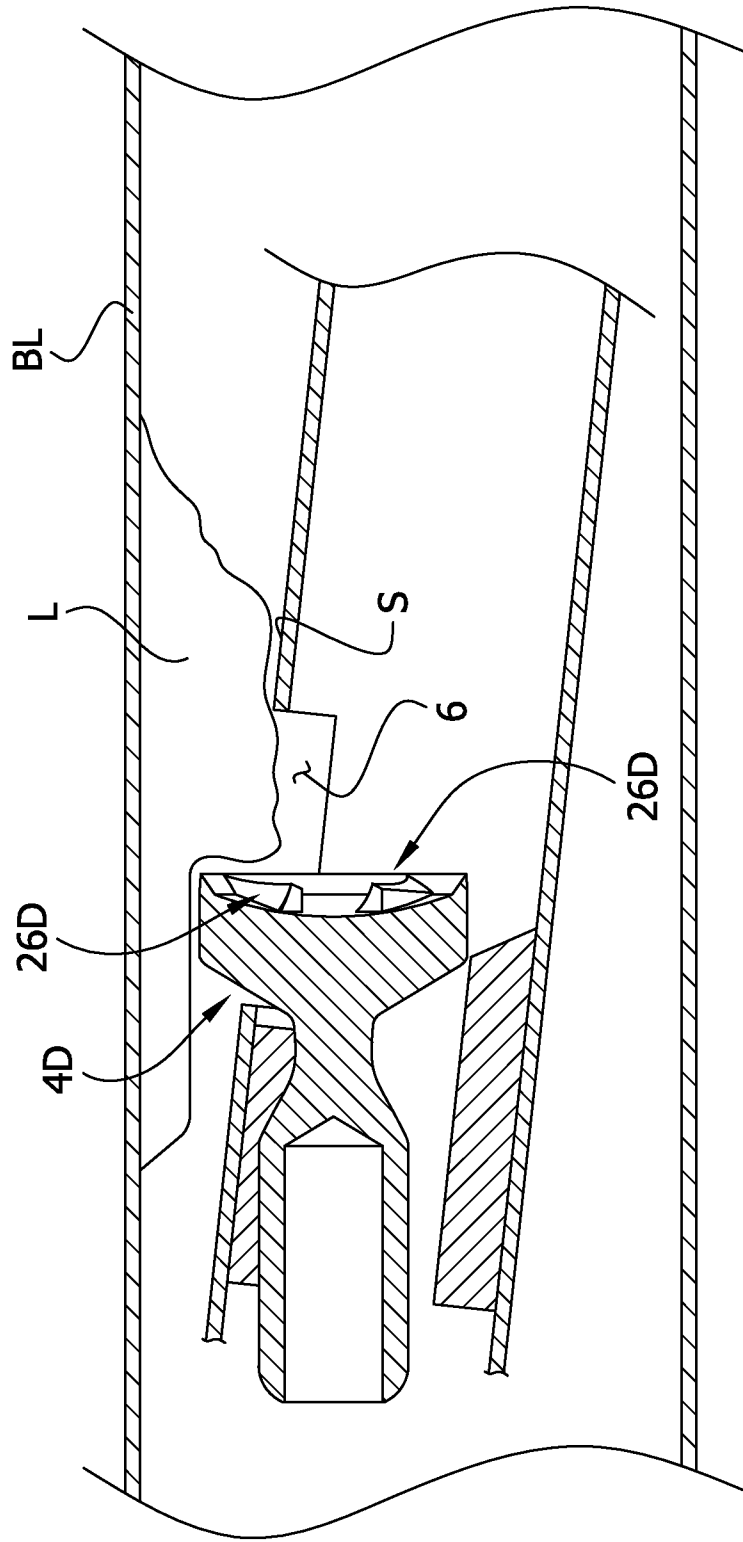

FIG. 18



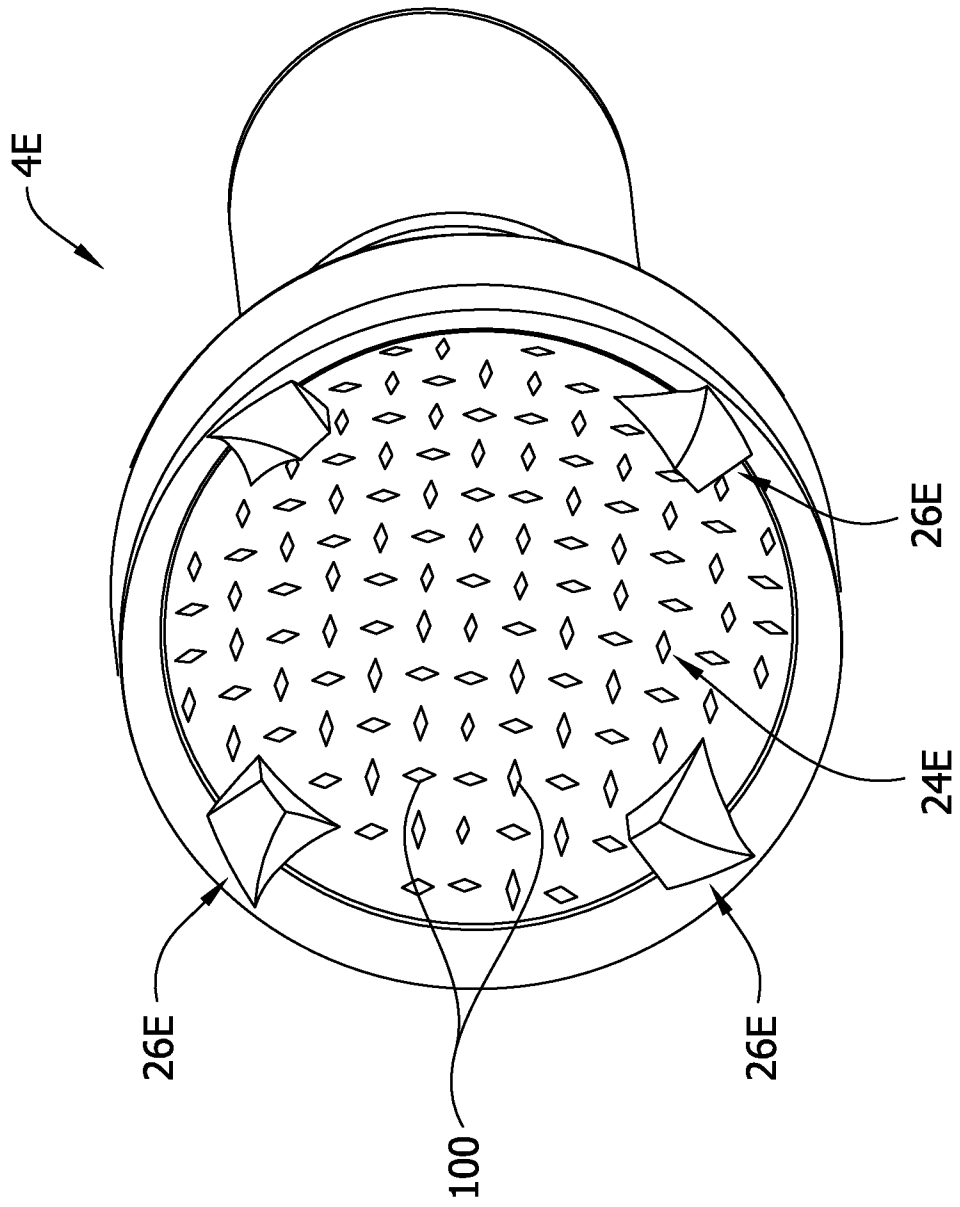

FIG. 19

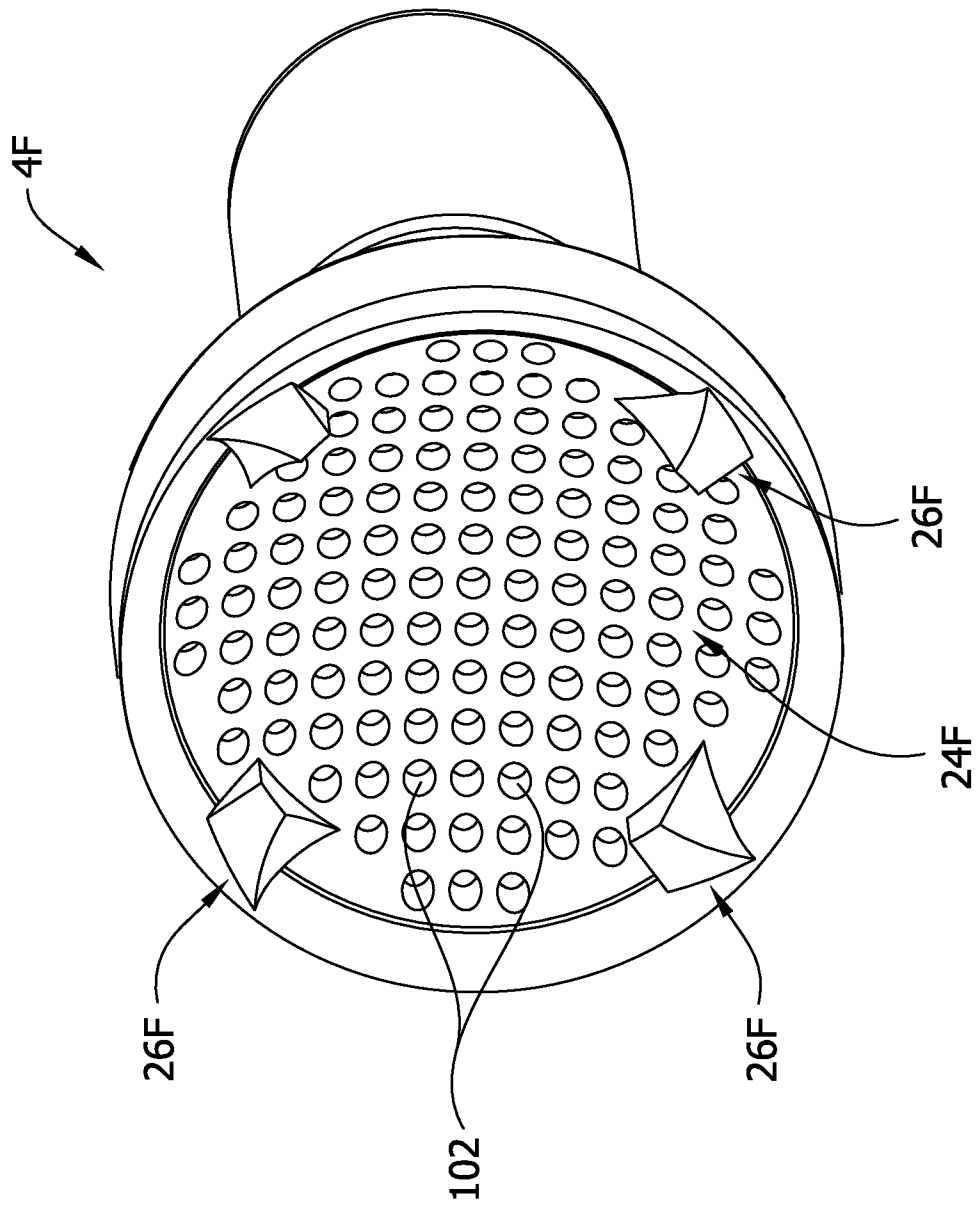

FIG. 20

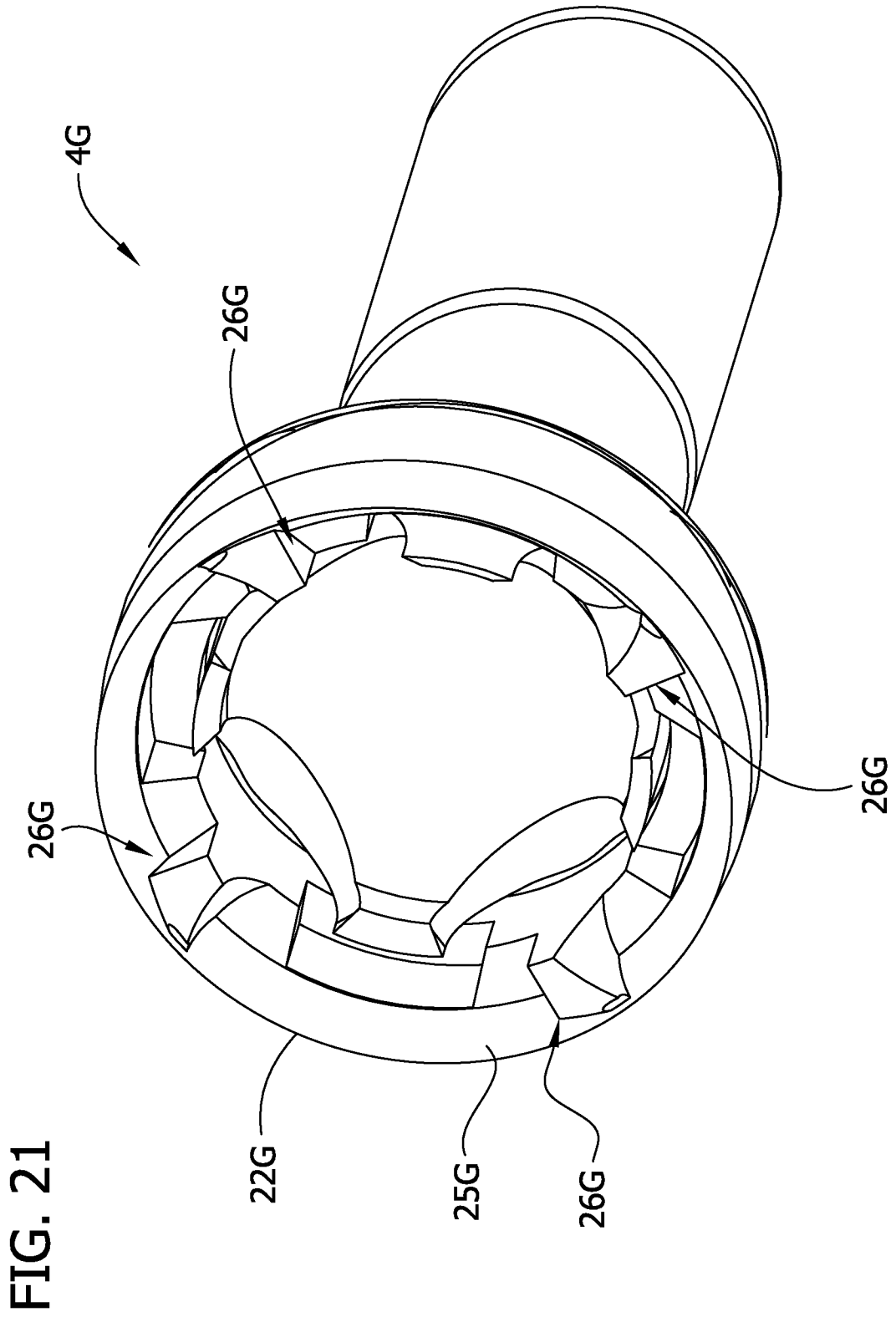

FIG. 22

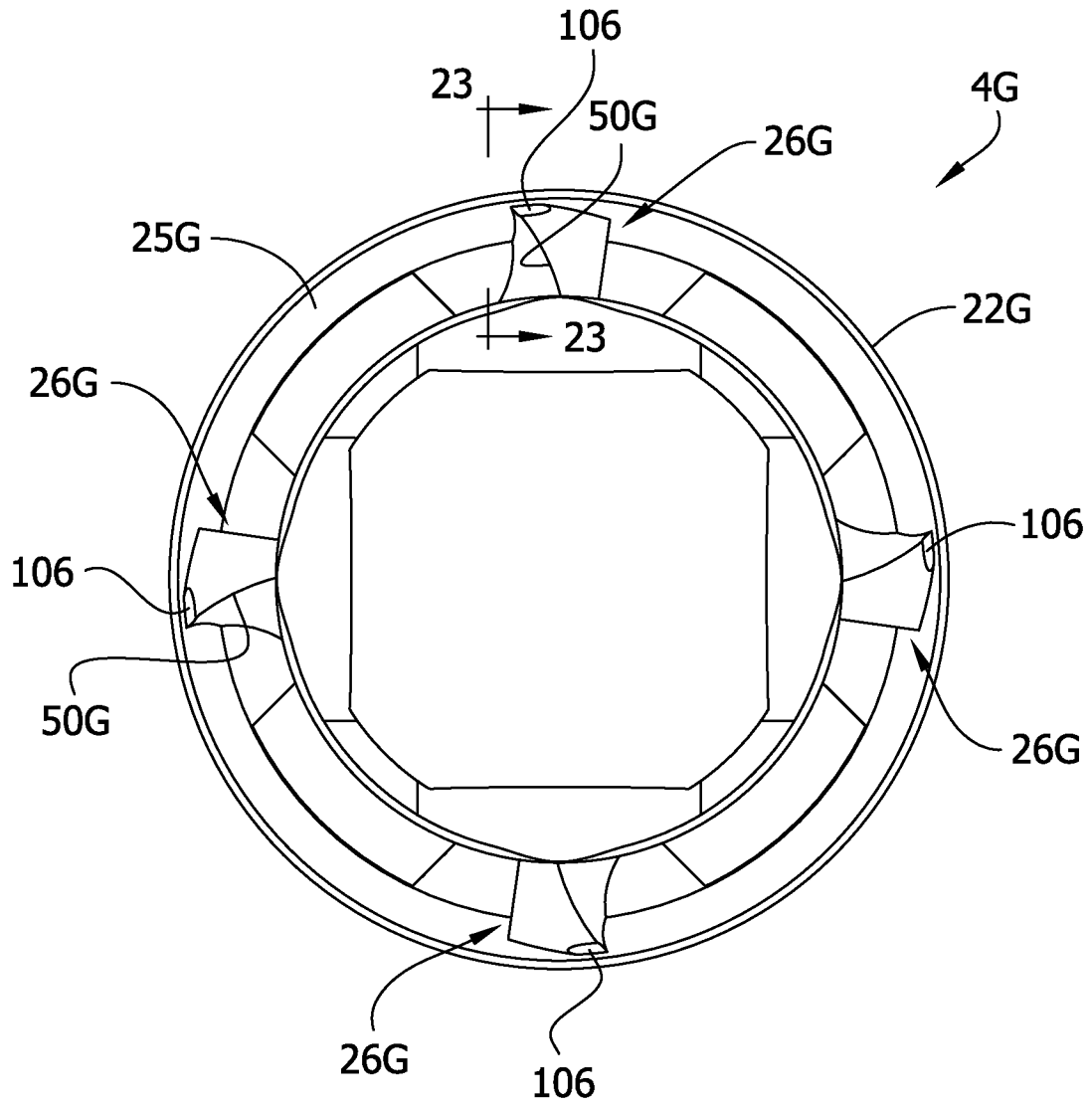

FIG. 23

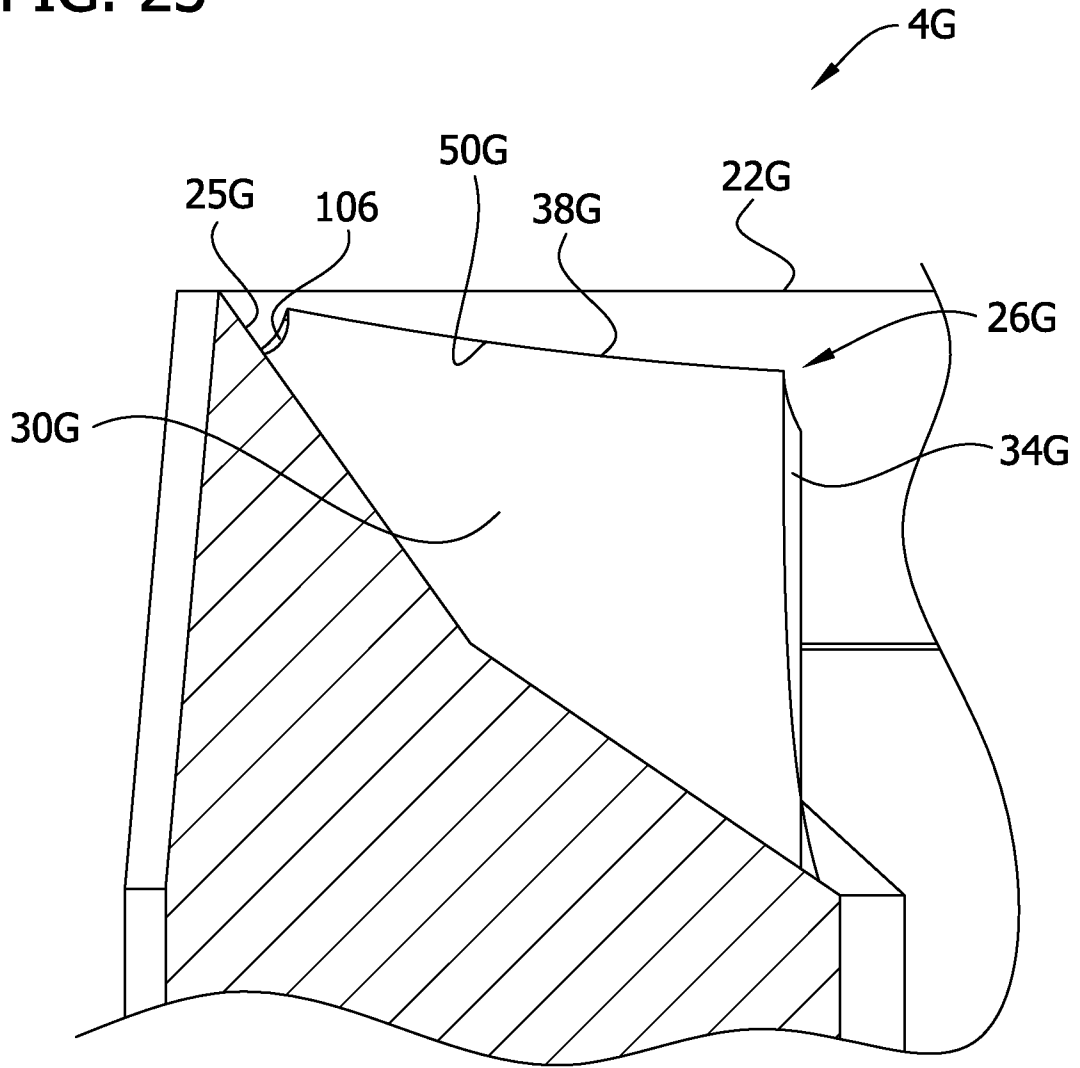
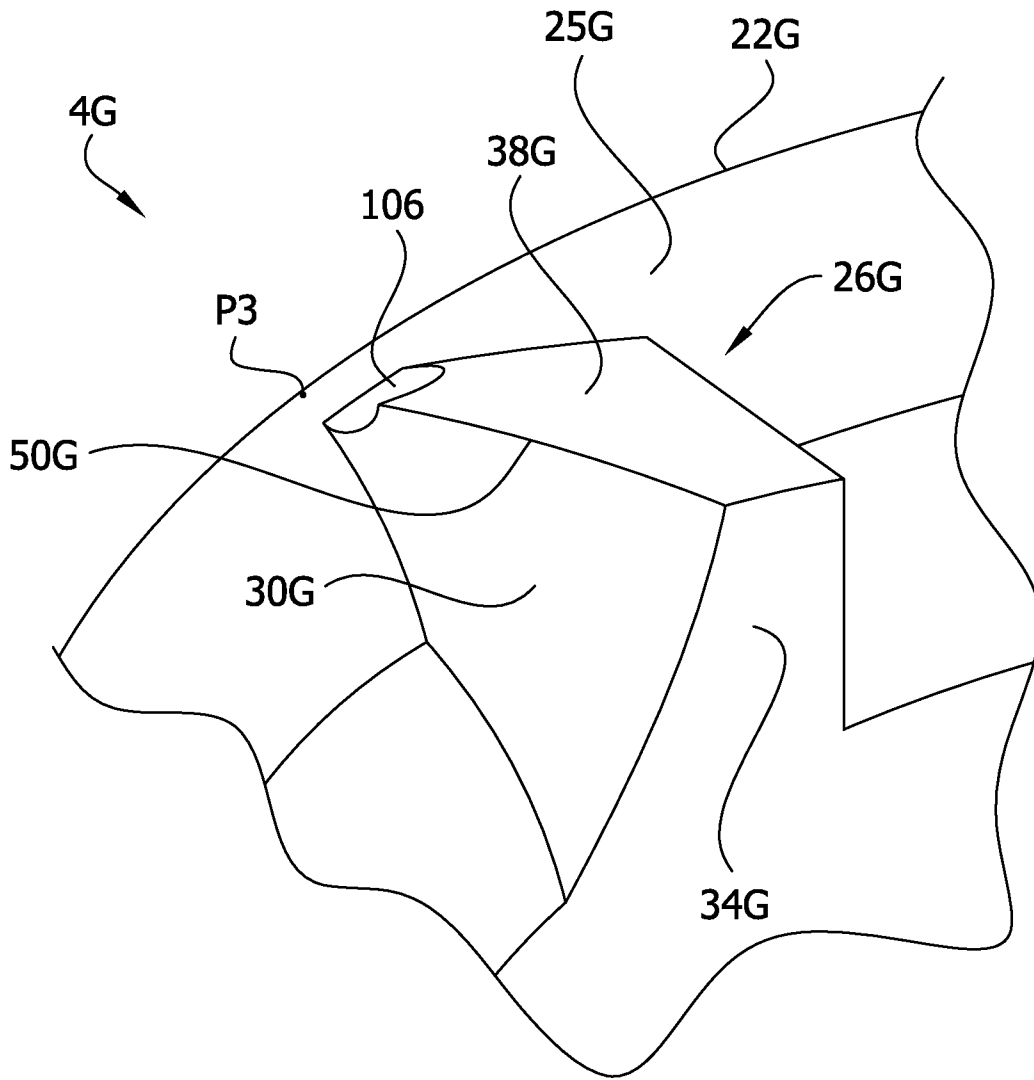
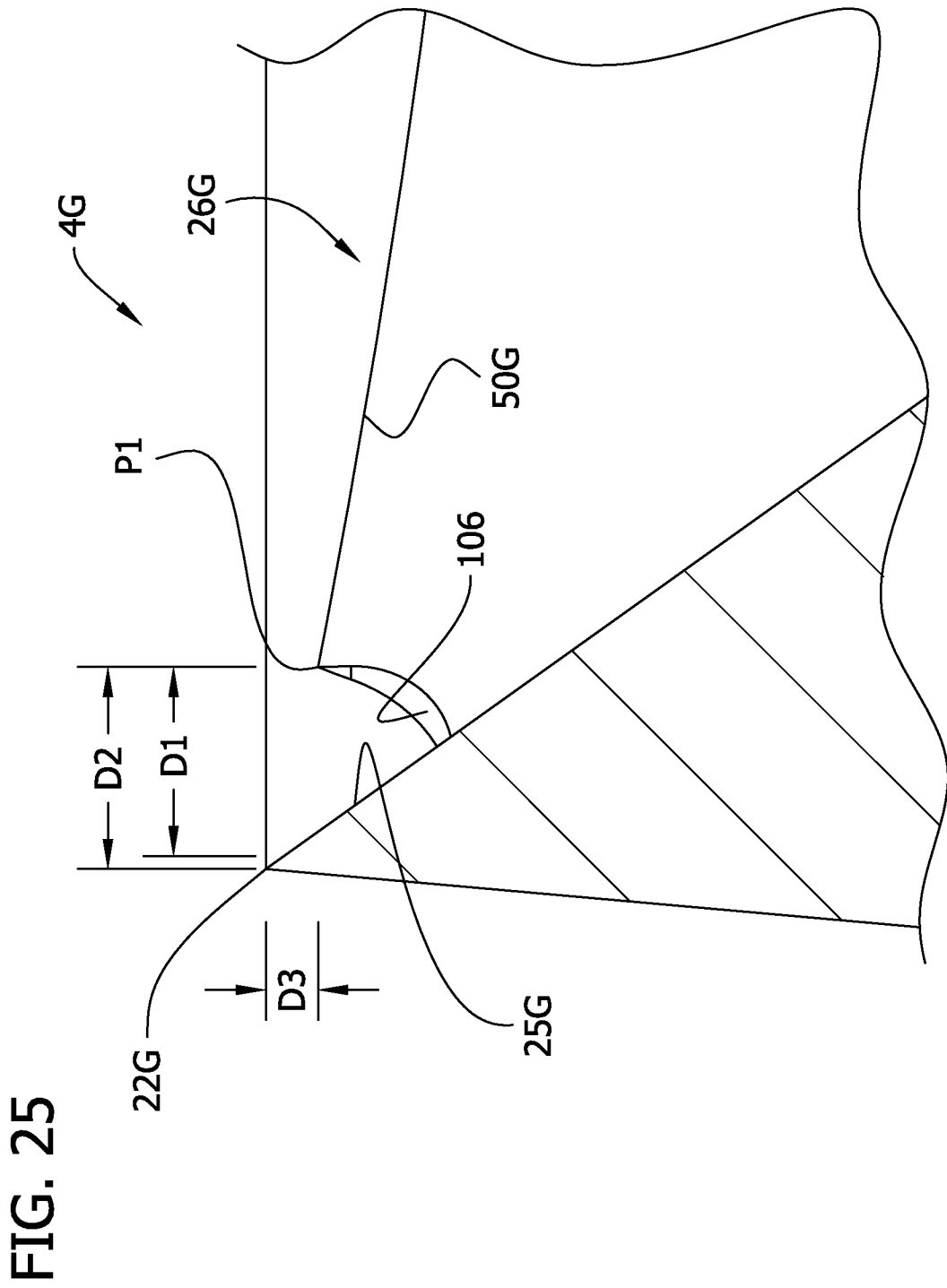

FIG. 24





INTERNATIONAL SEARCH REPORT

International application No
PCT/US2013/069045

A. CLASSIFICATION OF SUBJECT MATTER
INV. A61B17/3207
ADD.
According to International Patent Classification (IPC) or to both national classification and IPC

B. FIELDS SEARCHED
Minimum documentation searched (classification system followed by classification symbols)
A61B

Documentation searched other than minimum documentation to the extent that such documents are included in the fields searched

Electronic data base consulted during the international search (name of data base and, where practicable, search terms used)
EPO-Internal

C. DOCUMENTS CONSIDERED TO BE RELEVANT

Category*	Citation of document, with indication, where appropriate, of the relevant passages	Relevant to claim No.
X	US 2011/130777 A1 (ZHANG ET AL.) 2 June 2011 (2011-06-02)	1,7-17
A	abstract; figures paragraphs [0041] - [0060]	2,18
X	WO 2010/126882 A1 (FOX HOLLOW TECHNOLOGIES, INC.) 4 November 2010 (2010-11-04)	1,7,8, 10-16
A	abstract; figures paragraphs [0025] - [0033], [0038] - [0046]	2,18
X	US 2011/144673 A1 (ZHANG ET AL.) 16 June 2011 (2011-06-16)	1,7-14
A	abstract; figures 2-7,9,10A paragraphs [0035] - [0040]	2,15,18
	----- -/--	

Further documents are listed in the continuation of Box C.

See patent family annex.

* Special categories of cited documents :

- "A" document defining the general state of the art which is not considered to be of particular relevance
- "E" earlier application or patent but published on or after the international filing date
- "L" document which may throw doubts on priority claim(s) or which is cited to establish the publication date of another citation or other special reason (as specified)
- "O" document referring to an oral disclosure, use, exhibition or other means
- "P" document published prior to the international filing date but later than the priority date claimed

"T" later document published after the international filing date or priority date and not in conflict with the application but cited to understand the principle or theory underlying the invention

"X" document of particular relevance; the claimed invention cannot be considered novel or cannot be considered to involve an inventive step when the document is taken alone

"Y" document of particular relevance; the claimed invention cannot be considered to involve an inventive step when the document is combined with one or more other such documents, such combination being obvious to a person skilled in the art

"&" document member of the same patent family

Date of the actual completion of the international search 19 March 2014	Date of mailing of the international search report 02/04/2014
--	--

Name and mailing address of the ISA/ European Patent Office, P.B. 5818 Patentlaan 2 NL - 2280 HV Rijswijk Tel. (+31-70) 340-2040, Fax: (+31-70) 340-3016	Authorized officer Giménez Burgos, R
--	---

INTERNATIONAL SEARCH REPORT

International application No.
PCT/US2013/069045

Box No. II Observations where certain claims were found unsearchable (Continuation of item 2 of first sheet)

This international search report has not been established in respect of certain claims under Article 17(2)(a) for the following reasons:

1. Claims Nos.:
because they relate to subject matter not required to be searched by this Authority, namely:

2. Claims Nos.:
because they relate to parts of the international application that do not comply with the prescribed requirements to such an extent that no meaningful international search can be carried out, specifically:

3. Claims Nos.:
because they are dependent claims and are not drafted in accordance with the second and third sentences of Rule 6.4(a).

Box No. III Observations where unity of invention is lacking (Continuation of item 3 of first sheet)

This International Searching Authority found multiple inventions in this international application, as follows:

see additional sheet

1. As all required additional search fees were timely paid by the applicant, this international search report covers all searchable claims.
2. As all searchable claims could be searched without effort justifying an additional fees, this Authority did not invite payment of additional fees.
3. As only some of the required additional search fees were timely paid by the applicant, this international search report covers only those claims for which fees were paid, specifically claims Nos.:
4. No required additional search fees were timely paid by the applicant. Consequently, this international search report is restricted to the invention first mentioned in the claims; it is covered by claims Nos.:

Remark on Protest

- The additional search fees were accompanied by the applicant's protest and, where applicable, the payment of a protest fee.
- The additional search fees were accompanied by the applicant's protest but the applicable protest fee was not paid within the time limit specified in the invitation.
- No protest accompanied the payment of additional search fees.

FURTHER INFORMATION CONTINUED FROM PCT/ISA/ 210

This International Searching Authority found multiple (groups of) inventions in this international application, as follows:

1. claims: 1-14

Tissue removing catheter comprising: an elongated catheter having a window at a distal portion and an annular cutting element; wherein the annular cutting element is extendable through the window, during operation, less than an entire radial portion of the leading radial wall

2. claims: 15-17

Annular cutting element for a tissue-removing catheter comprising an annular cutting edge; an inner surface extending proximally from the cutting edge and defining a cavity; and at least one raised element in the internal cavity extending longitudinally outward from the inner surface; wherein the radial outermost portion of the at least one raised element is spaced apart radially from the inner surface of the cutting element.

3. claims: 18-25

Annular cutting element for a tissue-removing catheter comprising an annular cutting edge; an inner surface extending proximally from the cutting edge and defining a cavity; and at least one raised element in the internal cavity extending longitudinally outward from the inner surface; wherein the radial innermost portion of the at least one raised element is radially distance from the longitudinal axis less than about 66% of the radius of the annular cutting edge.

INTERNATIONAL SEARCH REPORT

International application No

PCT/US2013/069045

C(Continuation). DOCUMENTS CONSIDERED TO BE RELEVANT

Category*	Citation of document, with indication, where appropriate, of the relevant passages	Relevant to claim No.
A	EP 1 767 159 A1 (FOX HOLLOW TECHNOLOGIES, INC.) 28 March 2007 (2007-03-28) the whole document -----	1, 15, 18

INTERNATIONAL SEARCH REPORT

Information on patent family members

International application No

PCT/US2013/069045

Patent document cited in search report	Publication date	Patent family member(s)	Publication date	
US 2011130777	A1	02-06-2011	AU 2010326063 A1	07-06-2012
			CA 2781046 A1	09-06-2011
			CN 102695462 A	26-09-2012
			EP 2506783 A1	10-10-2012
			JP 2013512736 A	18-04-2013
			KR 20120079479 A	12-07-2012
			RU 2012121387 A	20-01-2014
			US 2011130777 A1	02-06-2011
			WO 2011068932 A1	09-06-2011

WO 2010126882	A1	04-11-2010	AU 2010241801 A1	17-11-2011
			CA 2760449 A1	04-11-2010
			CN 102625673 A	01-08-2012
			EP 2424450 A1	07-03-2012
			JP 2012525221 A	22-10-2012
			KR 20120011058 A	06-02-2012
			RU 2011143062 A	10-06-2013
			US 2010312263 A1	09-12-2010
			WO 2010126882 A1	04-11-2010

US 2011144673	A1	16-06-2011	AU 2010328078 A1	14-06-2012
			CA 2783301 A1	16-06-2011
			CN 102695463 A	26-09-2012
			EP 2509519 A1	17-10-2012
			JP 2013513442 A	22-04-2013
			KR 20120102108 A	17-09-2012
			KR 20140006106 A	15-01-2014
			RU 2012121843 A	20-01-2014
			US 2011144673 A1	16-06-2011
			US 2013018397 A1	17-01-2013
			WO 2011072149 A1	16-06-2011

EP 1767159	A1	28-03-2007	NONE	
