

April 15, 1930.

B. J. McCARTHY

1,754,635

BENDING APPARATUS

Filed July 13, 1928

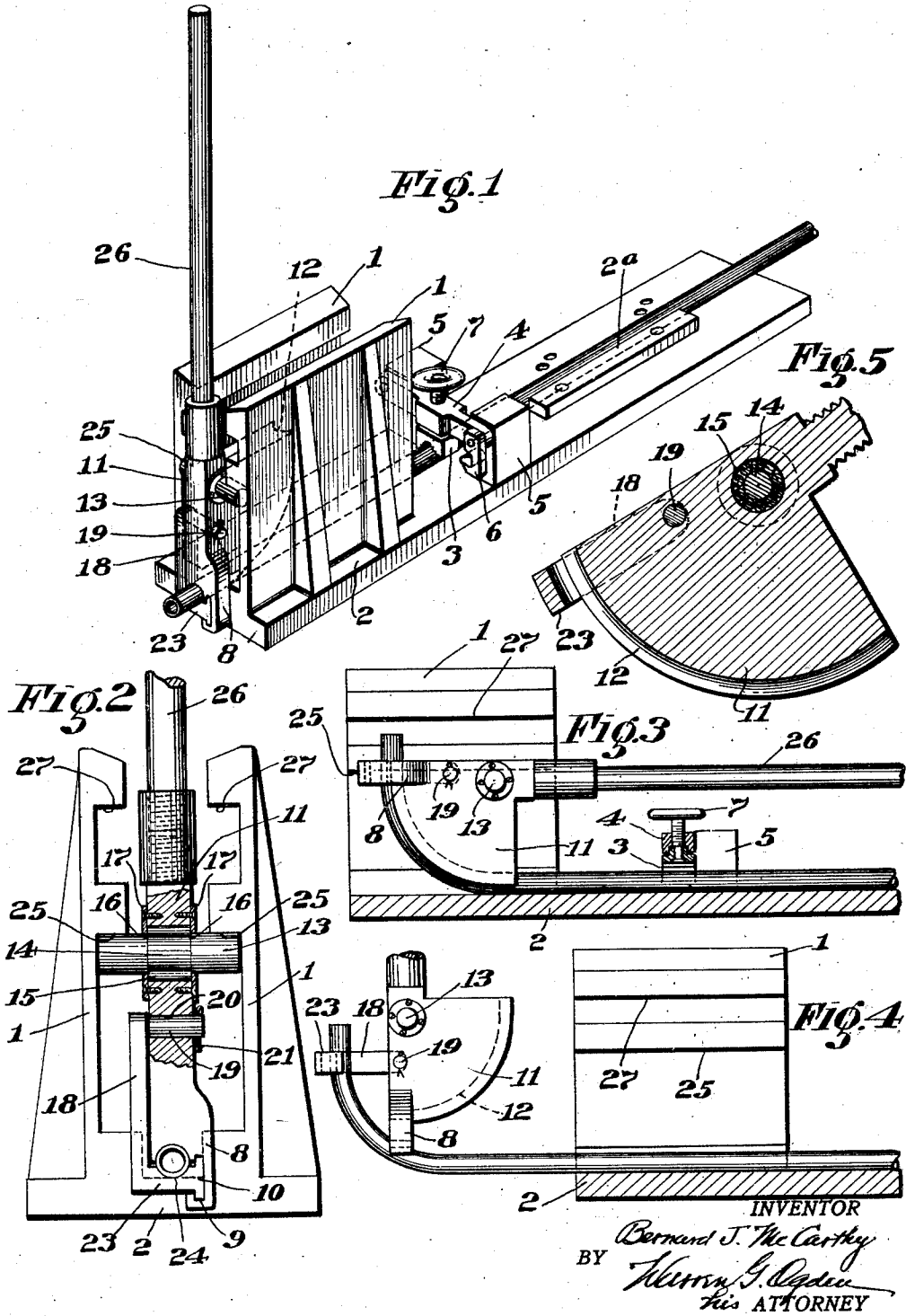

UNITED STATES PATENT OFFICE

BERNARD J. McCARTHY, OF JAMAICA PLAIN, MASSACHUSETTS

BENDING APPARATUS

Application filed July 13, 1928. Serial No. 292,443.

The present invention relates to bending apparatus which are employed by workmen in various trades, usually on the job, to provide bends or curvatures in pipe, particularly the kind that is used for electric wire conduits, and other metal pieces, such for instance as bus-bars, strips and rods.

Before the introduction of machine bending, pipe for electric wire conduits was usually bent in a vise through the use of a "hickey" which comprises a long handle having an offset hollow head. The pipe to be bent was clamped in a vise leaving a protruded end and the head of the hickey was then slipped on the protruding pipe end. Through the leverage of the long handle the pipe could be bent slightly about the corner of the vise which was unclamped, the pipe advanced, and then reclamped after each bending swing of the handle thus permitting successive portions of the pipe to be bent and the entire bend completed in a progressive manner. This method of bending the pipe is slow and laborious, is inaccurate, is impracticable when used to produce a large bend, an offset bend, a compound bend or a jug-handle bend, and is disfiguring particularly when the pipe is brass. Various mechanical devices or machines have been proposed as a substitute for the hickey some of which follow the progressive bending method and others of which propose to complete the bend by one operation.

The present invention provides for a continuous or single stroke, bending operation by mechanical means that provide for ease of operation with extreme accuracy, so that all the bends, made in different pipes placed successively in the machine, will be alike and thus promote a neat assembly on the job.

The principal object of the present invention is to produce a bending apparatus of the character described which insures a bend on the desired radius, is of simple construction so that it may be operated by ordinary workmen, and requires the least amount of power.

To the accomplishment of this object, a feature of the present invention contemplates the provision in a bending apparatus

having a form, of means for imparting to the form a motion substantially like that of a cylinder rolling on a plane to bend the pipe. It will be apparent to those skilled in the art that with this construction the portion of the pipe to be bent is wrapped about the periphery of the form while its unbent portion remains stationary.

Broadly considered the means for imparting to the form a motion substantially like that of a cylinder rolling on a plane to bend the pipe may take any suitable form found desirable or convenient. It is preferred, however, to mount the form on a mobile axis and provide means for applying the form progressively to the portion of the pipe to be bent.

Further features of the present invention consist in certain devices, combinations and arrangements of parts tending to improve and simplify the operation of pipe bending apparatus whereby the bent pipe is readily removable from the form and whereby liability of breakage of parts is avoided. The advantages of these devices, combinations and arrangements of parts will be obvious to those skilled in the art from the following description.

The various features of the present invention will be readily understood from an inspection of the accompanying drawings illustrating the best form of the invention at present known to the inventor, in which:—

Figure 1 is a view, in perspective, of the bending apparatus, the work therein being a pipe;

Fig. 2 is a detail view, in rear elevation, and partly in section;

Fig. 3 is a view, in longitudinal sectional elevation, showing the position of the parts after the bend in the pipe has been formed;

Fig. 4 is a view, in longitudinal sectional elevation, showing how the bending form is disengaged from the bent pipe; and

Fig. 5 is a detail view, in sectional elevation, of the bending form and the clevis for clamping the pipe to the form.

In the illustrated embodiment of the invention the bending apparatus comprises a casting having a pair of spaced vertical

standards 1 rising therefrom. The pipe, or other work, to be bent rests on the bed 2 between the standards and this bed may be elongated, if desired, as shown in Fig. 1.

5 The pipe is assembled with the standards by laying it therebetween on the bed, one end protruding to any desired amount from the rear end of the standards according to the location of the bend with relation to the end of the pipe, and is held centrally of the standards by a clamping jaw 3. The clamping jaw may be mounted in any convenient location relative to the standards. As illustrated the jaw 3 is supported by a frame 4 pivoted at one end to one of a pair of posts 5 (Figs. 1 and 3) rising from the bed 2, and secured by a latch 6 to the other post. The jaw is mounted, in any usual manner, for vertical travel in its frame through rotation of a hand wheel 7.

10 In order to bend the pipe a bending device, to be operated by the workman, is applied to the protruding end of the pipe. This bending device comprises a form 11, herein shown as a sector, having a peripheral, pipe-receiving groove 12 in its periphery. The form 11 is mounted on a horizontal shaft 13 the free ends of which protrude and form hubs at each side of the form. The shaft 13 at its center is provided with a reduced portion 14 and interposed between the portion 14 and the form are roller bearings 15 which may be held in place merely by the shoulders 16 of the reduced portion 14. As herein shown, however, the opposite ends of the bearings 15 are caged by annular plates 17 secured to the form 11.

15 The form 11 is provided with a clevis 18 which is pivoted on the form by an off-center pin 19 extending loosely through an opening 20 and held in position therein by a split pin 21 or other convenient means. The pin 19 is secured to a leg of the clevis which lies against one of the side faces of the form 11. The bottom of the clevis comprises an offset 23 which extends across the peripheral face of the form 11 and may be used as a stop to position the form with respect to the rear end of the bed 2 (see Figs. 1 and 2) before starting to bend the pipe. The offset 23 is provided with a groove 24 which co-operates with the groove 12 to form a circular opening the walls of which grip the pipe.

20 The form 11 and clevis 18 may be slipped over the free end of the pipe lying on the bed or the pipe may be inserted into the opening formed by the closed clevis and groove. In the starting position shown by Fig. 1 the ends of the shaft 13 are positioned beneath tracks 25, each track being formed on a standard 1.

25 While a simple form of clevis comprising merely the parts 18, 19 and 23 may have sufficient strength for the smaller sizes of pipe it is preferred to provide a lock for additional

strength. The lock preferably takes the form of a lug 8, which may be integral with the form 11, having an arcuate track 9 for reception of a T-shaped head 10 on the offset 23. The arc of the track 9 is on a radius having the pin 19 as a center so that on rotating the clevis about the pin a locking engagement with the lug 8 is effected.

70 If found desirable the pipe may be additionally centered on the bed 2 by means of a gage bar 2^a having pins for locating it in one or another pair of a series of holes drilled in the bed at different distances from the medial line of the two standards 1 thus accommodating the bar to gaging the position of different sizes of pipe.

75 In order to operate the form to bend the pipe the form is provided with a handle 26 which, for a full 90° bend, is swung downward from the position of Fig. 1 to that of Fig. 3. During this movement of the handle the form rolls on the pipe with a motion substantially like that of a cylinder rolling on a plane as the hubs of the shaft 13 roll on the tracks 25 substantially from one end to the other thereof. With this construction and mode of operation the pipe is wrapped into the groove 12 with no tendency or requirement for the unbent portion of the pipe to move longitudinally on the bed 2. The entire force exerted in swinging the handle 26 from the position of Fig. 1 to that of Fig. 3 is utilized in bending the pipe. It will be apparent from an inspection of Fig. 3 that the arc through which the handle 26 is swung determines the degree or character of bend with which the pipe is provided. It will also be apparent that the tracks 25 resist any tendency of the shaft 13 to move vertically during the bending operation.

85 In order to remove the form from the bent pipe the form and pipe are pushed rearwardly until the hubs of the shaft 13 ride out of engagement with the tracks 25 whereupon the form may be swung away from the bent pipe on the pin 19 as a pivot (see Fig. 4). The clevis 18 may then be slipped off the pipe and the bent pipe is free of the form.

90 If it is desired to provide the pipe with a larger bend than that shown in Fig. 4 a form 11 comprising a sector having a larger radius is employed. In using this larger form the free ends of the shaft 13 are positioned beneath upper tracks 27 on the standards 1. Otherwise the bending operation is the same. As many pairs of tracks as required may be provided.

95 It is possible, however, to bend pipes of slightly different sizes using only the track 25. For example, if the apparatus illustrated is designed for imparting a 3½" radius bend to a ½" pipe, a bend of the same radius may be made in a ¾" pipe by using a form 11 having a 3¾" groove but also having its rolling hubs ⅛" less in diameter than the diam-

70

75

80

85

90

95

100

105

110

115

120

125

130

eter of the hubs on the form used for the 1/2" pipe. This difference in diameter accommodates the increased height of the shaft 13, due to the larger sized pipe, to the same height of track above the bed 2. The upper track 27 may likewise be used for providing pipe differing slightly in diameter with bends of the same radius.

It will be apparent to those skilled in the art of bending pipe that the pipe bending apparatus embodying the features of the present invention enables the workman to provide a bend or curvature of the exact dimensions required because the form 11 acts as a templet for accurately determining the curvature, the arc of which may be readily varied through variation in the distance through which the handle 26 is swung. In electrical work many pipe conduits for the wires may have to be in parallel relation on the ceiling and then be brought around a corner of the room so that at the corners the pipe conduits are nested. The herein disclosed pipe bending apparatus permits the bending of the pipe conduits so that their bends will lie concentric to each other. It also permits making a bend, termed a jug-handle, which requires first forming a large bend and then bending the pipe on opposite sides of the bend in opposite directions reversely in curvature to that of the first bend. To make an offset or compound bend the bed 2 is mounted on an elevated surface so that after the first bend is made as hereinbefore described, the bend is directed downward so that the clevis 18 may be located on the unbent portion of the pipe in readiness for the second bend. In fact, any bend that can be accomplished by the ordinary hickey can be performed by the machine of this invention, faster, easier and with greater accuracy as to measurement, nor is it necessary to fill the portion to be bent with sand to prevent flattening of the pipe during bending as is usually necessary when using a hickey.

It will be clear to those skilled in this class of machines and with the general objects of the present invention in view, that changes may be made in the details of structure, the described and illustrated embodiment thereof being intended as an exploitation of its underlying essentials the features whereof are definitely stated in their true scope in the appended claims.

What is claimed as new, is:—

1. In a pipe bending apparatus, the combination with a rotatable form, having a horizontal shaft and a clevis for clamping the pipe to the form, and standards between which the form rotates having a track under which the ends of the shafts are positioned, of means for rotating the form on the shaft and reciprocating the shaft along the track to apply the form progressively to the portion of the pipe to be bent.

2. In a pipe bending apparatus, the combination with a base member having a guide for the pipe, a pair of spaced standards rising from the base each provided with at least one track, a form removably mounted between the standards and provided with a horizontal shaft the free ends of which engage the under surfaces of the tracks and also with a clevis for clamping the work to the form, of means for rotating the form on the shaft and reciprocating the shaft along the tracks to apply the form progressively to the portion of the pipe to be bent.

3. Pipe bending apparatus comprising a pair of spaced standards having a bed therebetween and oppositely disposed tracks above the bed, one track on each standard, means for clamping a pipe on the bed, and a curved bending form having means for gripping the pipe and adapted to travel along the tracks for raising the portion of the pipe between the standards and bending it to the curvature of the form while the remainder of the pipe is held clamped on the bed.

4. Apparatus for bending a longitudinally fixed pipe comprising a curved bending form having means for gripping the pipe and an operating handle, and a cage comprising tracks constraining the form to move longitudinally of the fixed pipe when the handle is moved in a direction to cause the form to roll along the pipe.

In testimony whereof I affix my signature.
BERNARD J. McCARTHY.

70

75

80

85

90

95

100

105

110

115

120

125

130