



US 20080319444A9

(19) **United States**
(12) **Patent Application Publication**
Osorio et al.

(10) **Pub. No.: US 2008/0319444 A9**
(48) **Pub. Date: Dec. 25, 2008**
CORRECTED PUBLICATION

(54) **METHODS AND DEVICES FOR TREATING BONE AFTER HIGH VELOCITY AND/OR TRAUMA FRACTURE**

See (63) Related U.S. Application Data and (60) Related U.S. Application Data.

(65) US 2003/0233096 A1 Dec. 18, 2003

(75) Inventors: **Reynaldo A. Osorio**, Daly City, CA (US); **Marialulu Follmer**, Santa Clara, CA (US); **Richard W. Layne**, San Francisco, CA (US); **Ryan P. Boucher**, San Francisco, CA (US); **Karen D. Talmadge**, Palo Alto, CA (US); **Joseph J. Basista**, Mountain View, CA (US)

Related U.S. Application Data

(63) Continuation-in-part of application No. 09/827,260, filed on Apr. 5, 2001, now Pat. No. 6,726,691. Continuation-in-part of application No. 09/754,451, filed on Jan. 4, 2001, now Pat. No. 6,899,719, which is a continuation of application No. 08/871,114, filed on Jun. 9, 1997, now Pat. No. 6,248,110.

(60) Provisional application No. 60/194,685, filed on Apr. 5, 2000.

Correspondence Address:
HAYNES AND BOONE, LLP
901 Main Street
Suite 3100
Dallas, TX 75202 (US)

Publication Classification

(73) Assignee: **Kyphon Inc.**

(51) **Int. Cl.**
A61F 5/00 (2006.01)
(52) **U.S. Cl.** **606/86 R**

(21) Appl. No.: **10/397,049**

(22) Filed: **Mar. 25, 2003**

(57) **ABSTRACT**

Prior Publication Data

Devices and methods treat bone after high velocity and/or trauma fracture, using various devices, including cavity-forming devices.

(15) Correction of US 2003/0233096 A1 Dec. 18, 2003

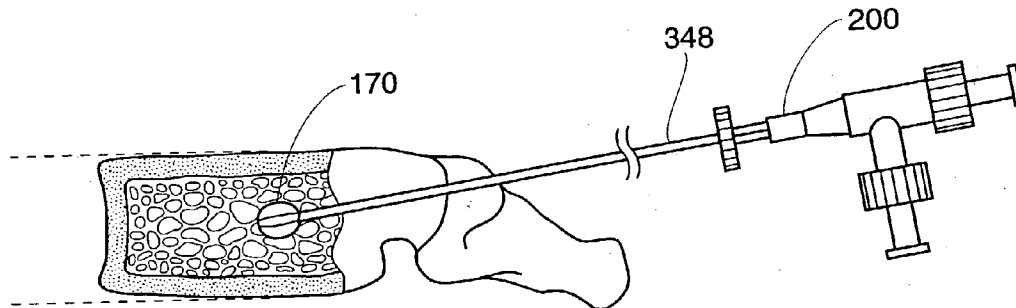

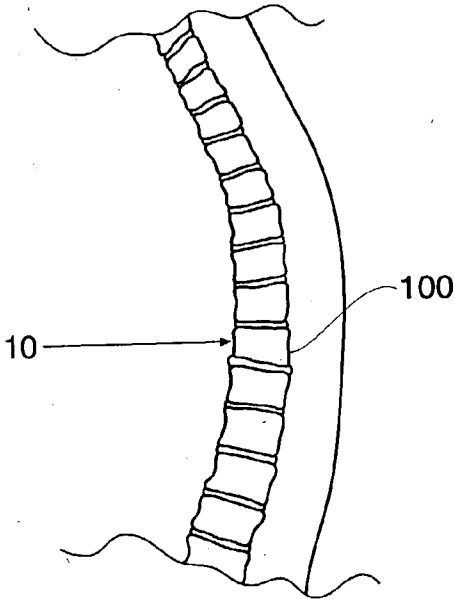

Fig. 1

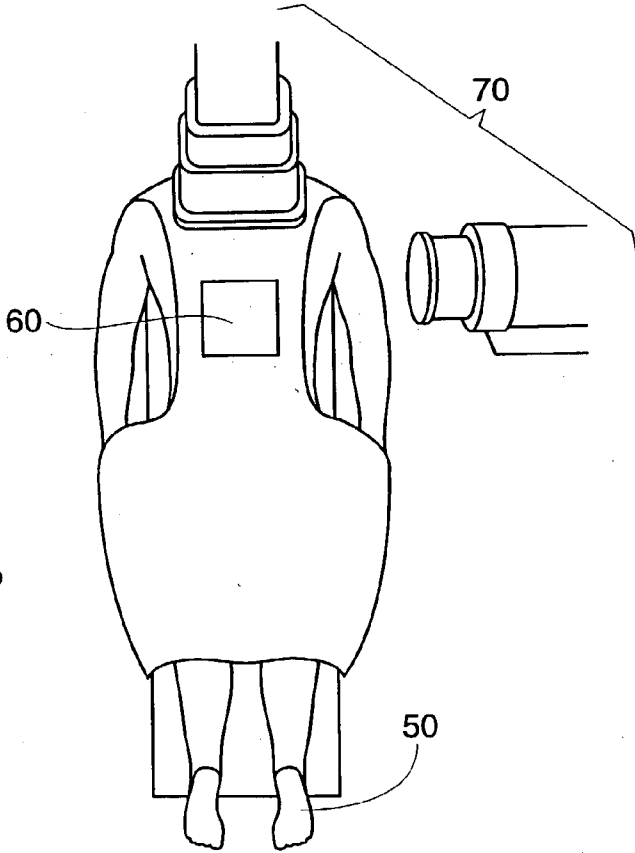

Fig. 2

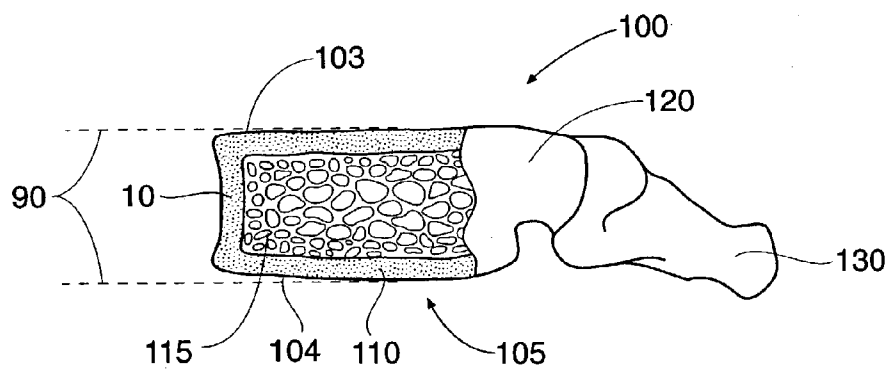

Fig. 3

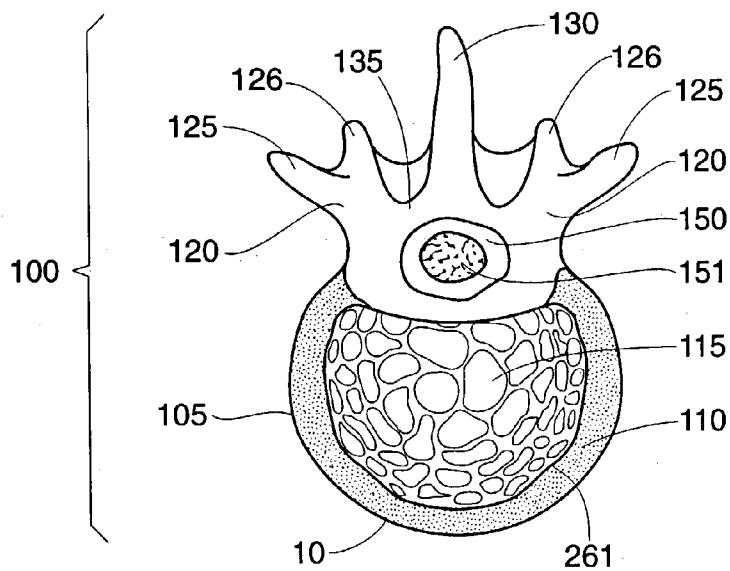

Fig. 4

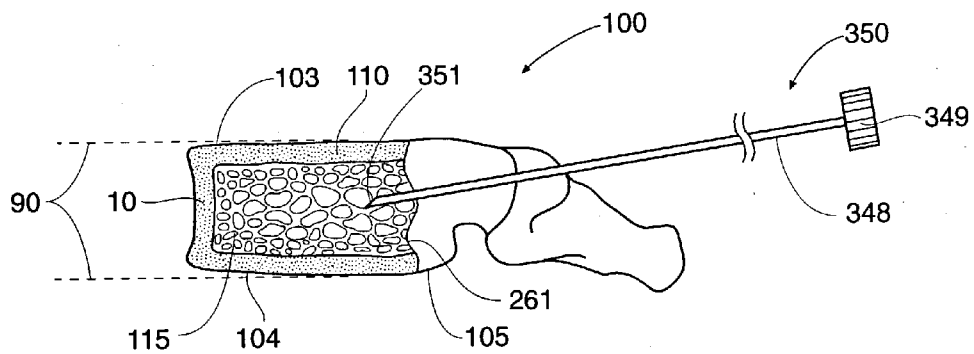

Fig. 5a

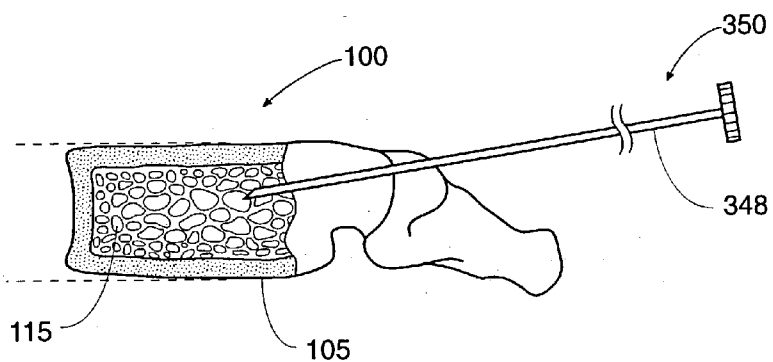

Fig. 5b

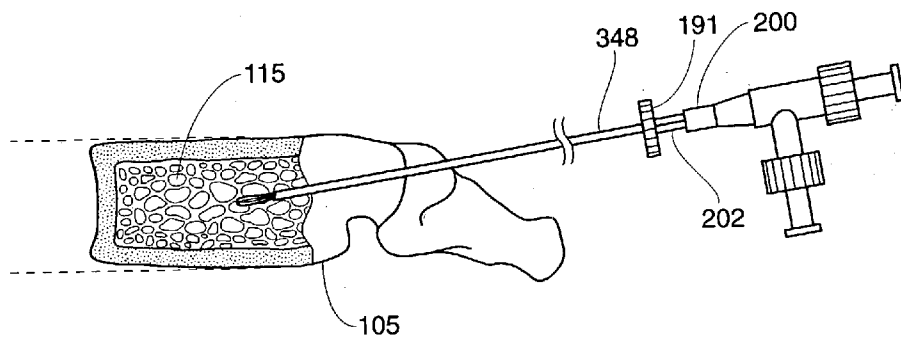

Fig. 5c

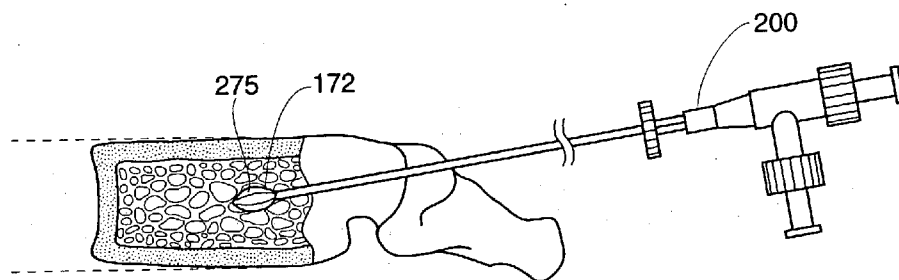

Fig. 5d

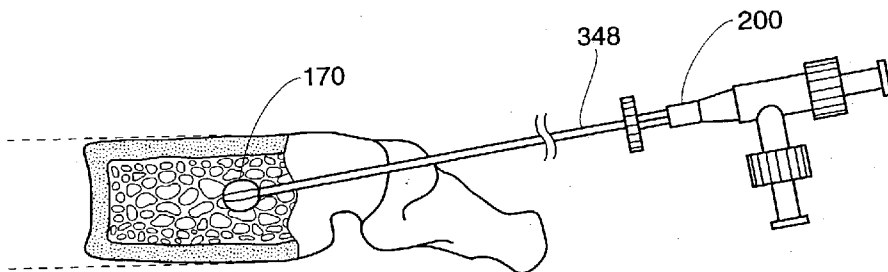

Fig. 5e

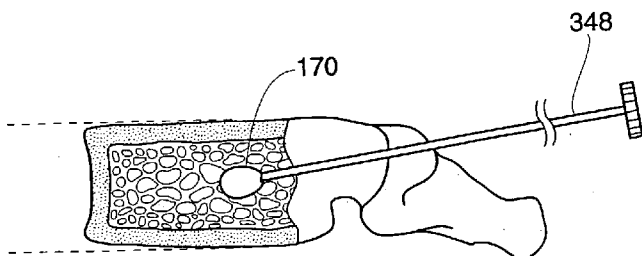

Fig. 5f

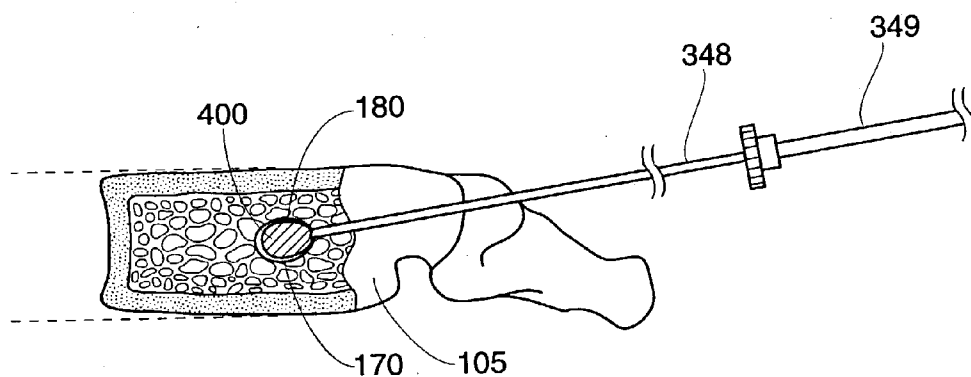

Fig. 5g

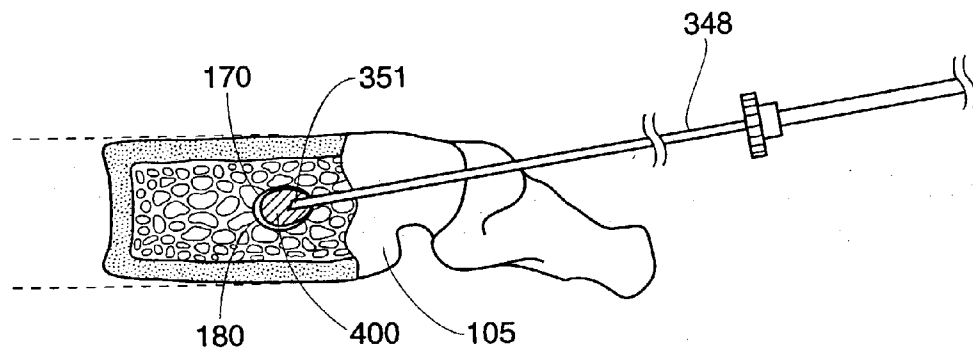

Fig. 5h

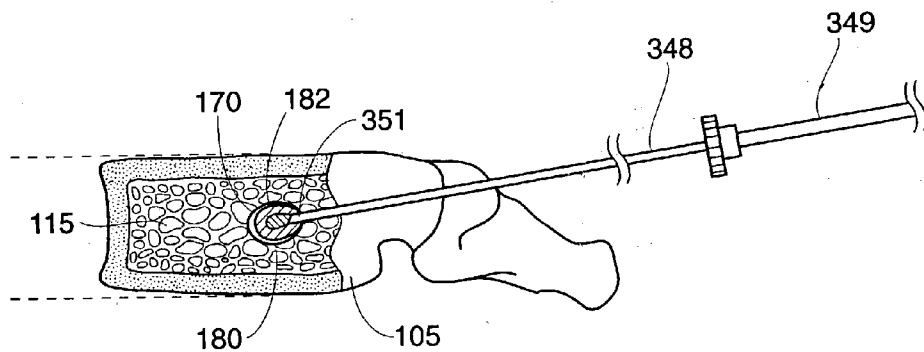

Fig. 5i

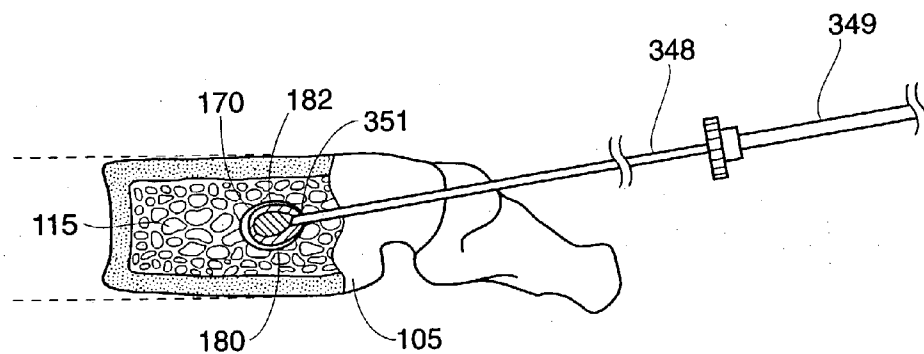

Fig. 5j

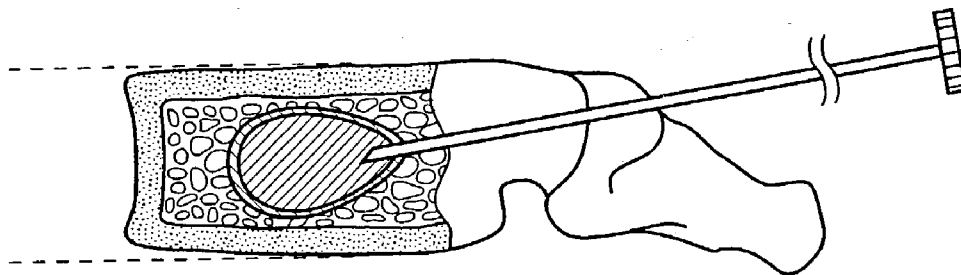

Fig. 5k

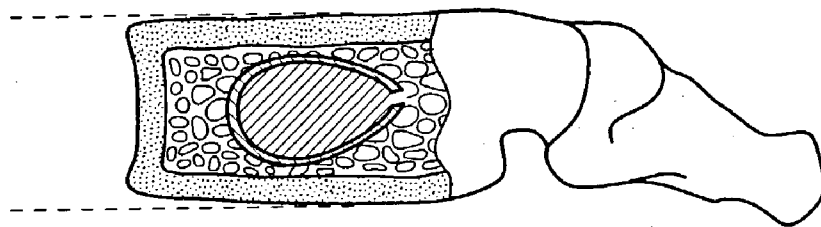

Fig. 5l

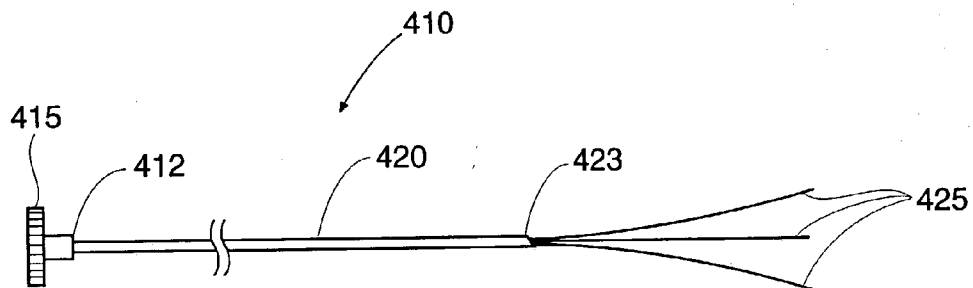

Fig. 6a

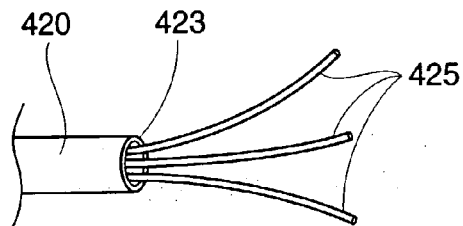

Fig. 6b

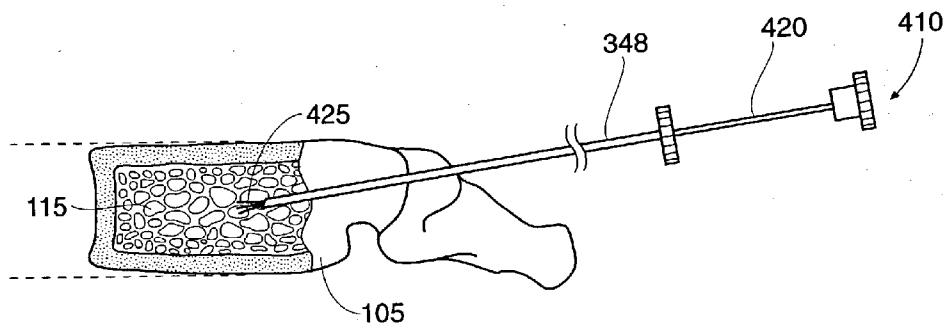

Fig. 7a

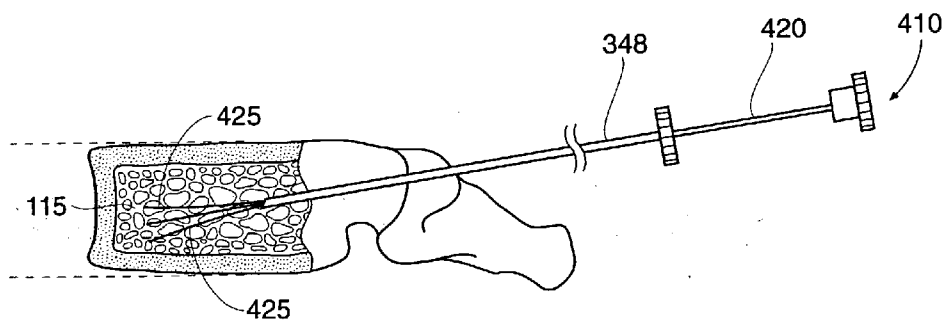

Fig. 7b

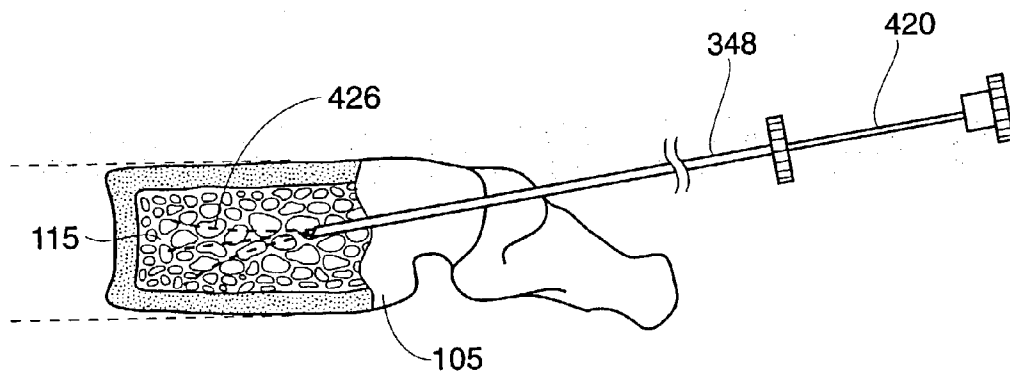

Fig. 7c

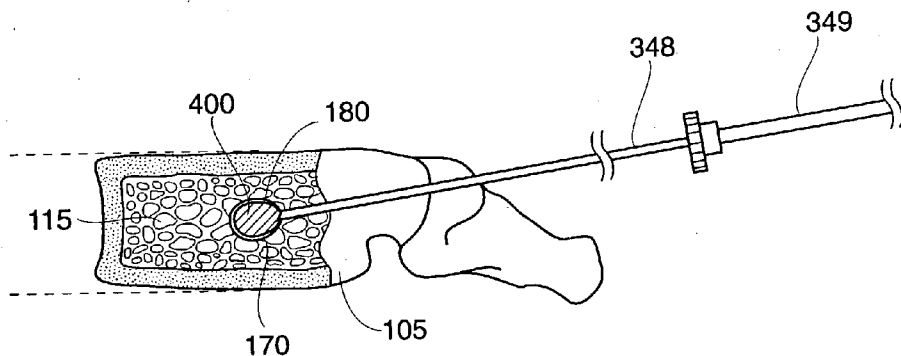

Fig. 8a

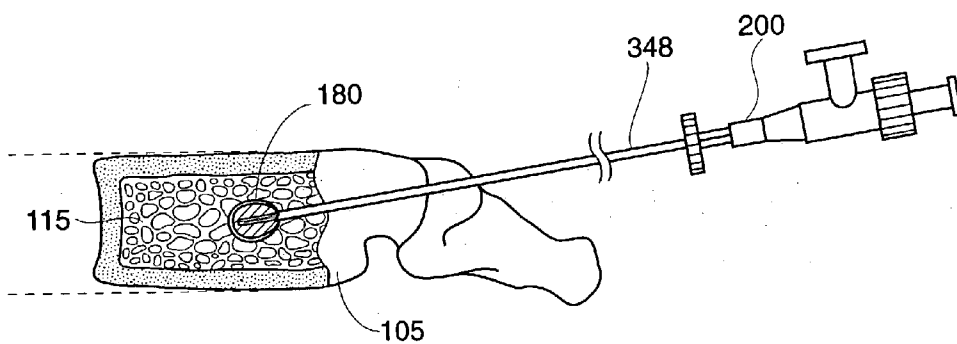

Fig. 8b

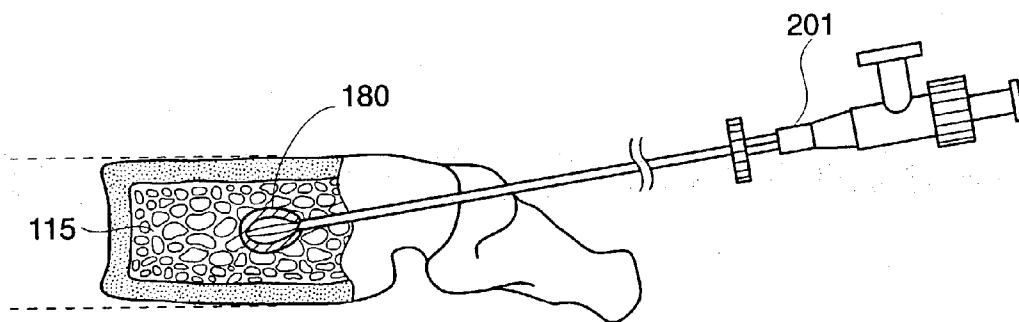
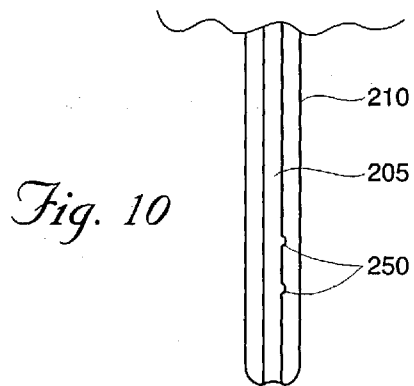
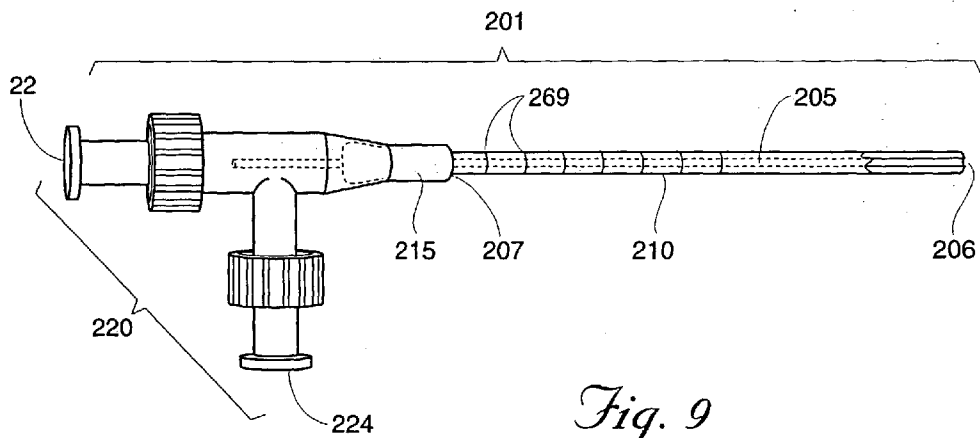

Fig. 8c



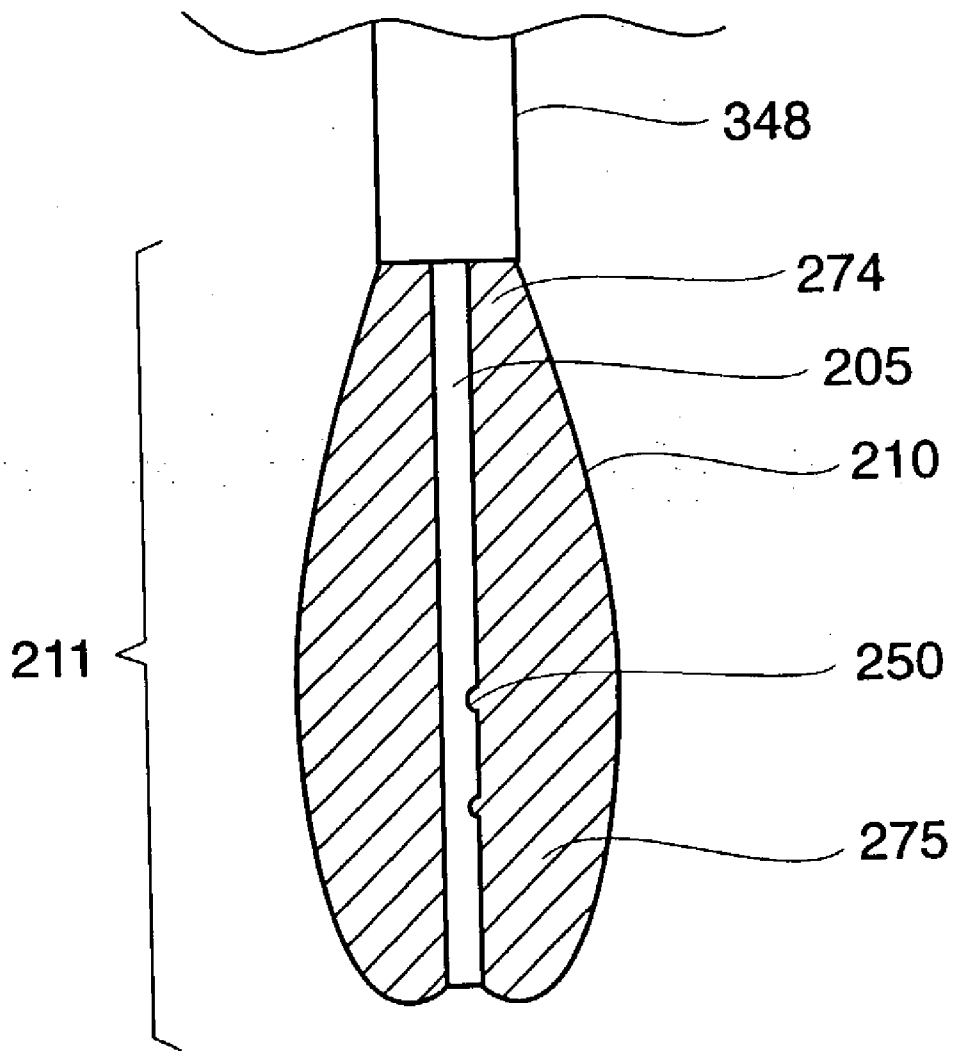

Fig. 11

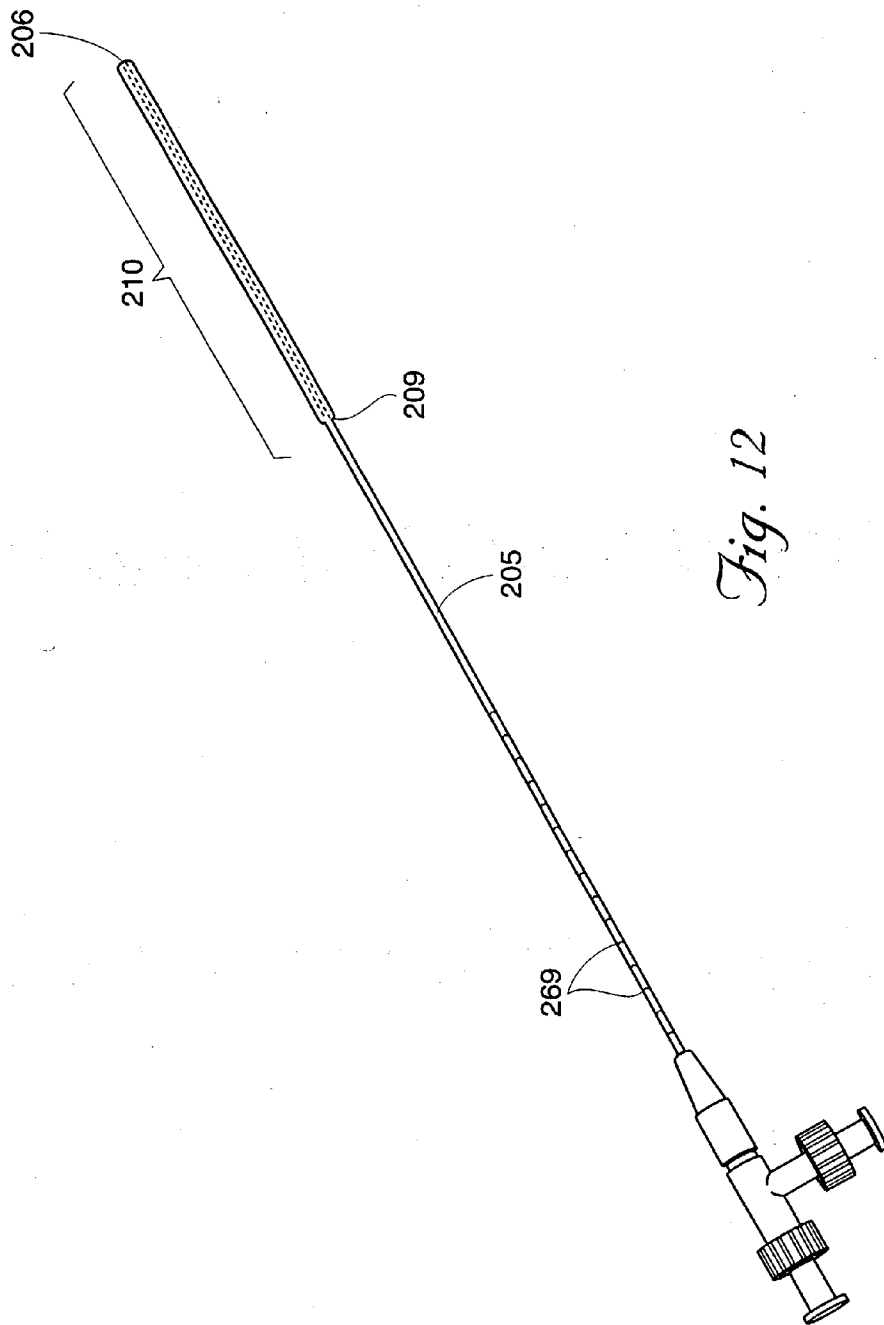

Fig. 12

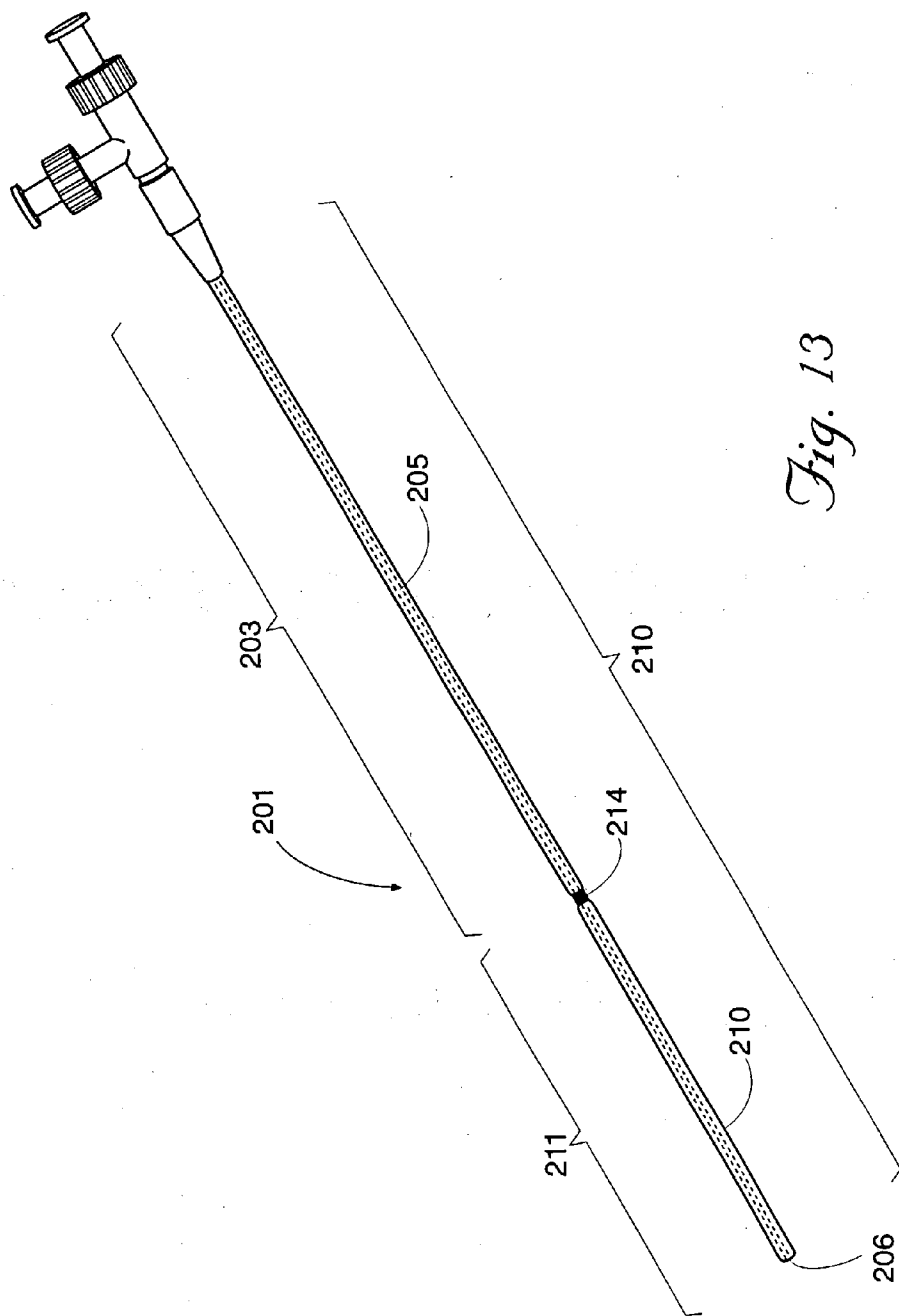

Fig. 13

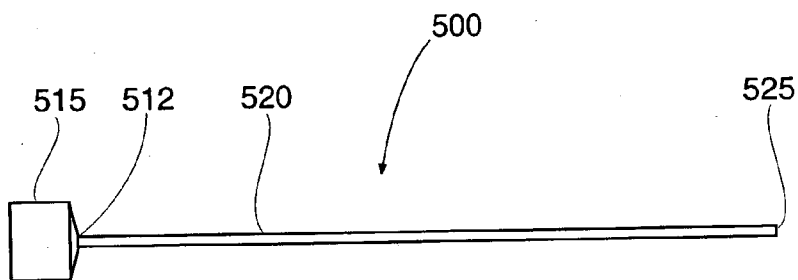

Fig. 14

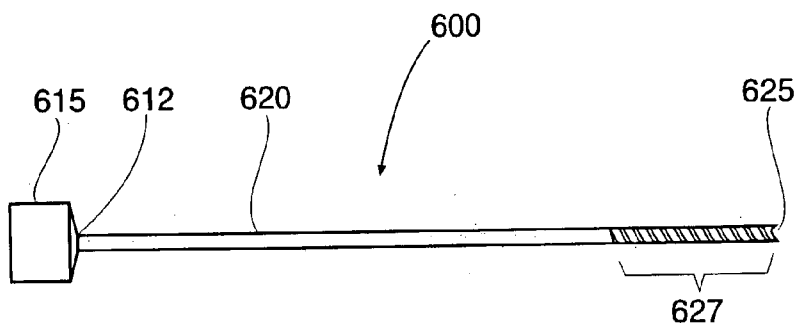

Fig. 15

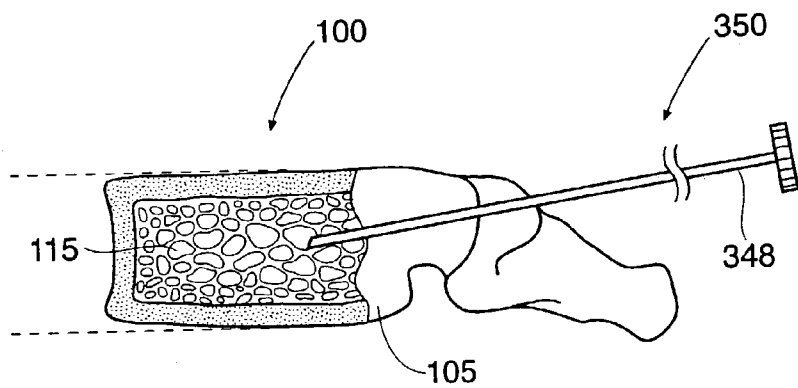

Fig. 16a

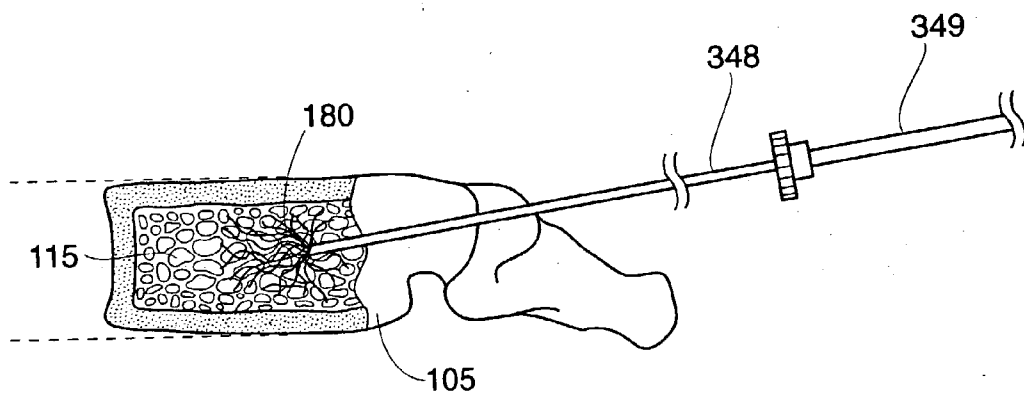

Fig. 16b

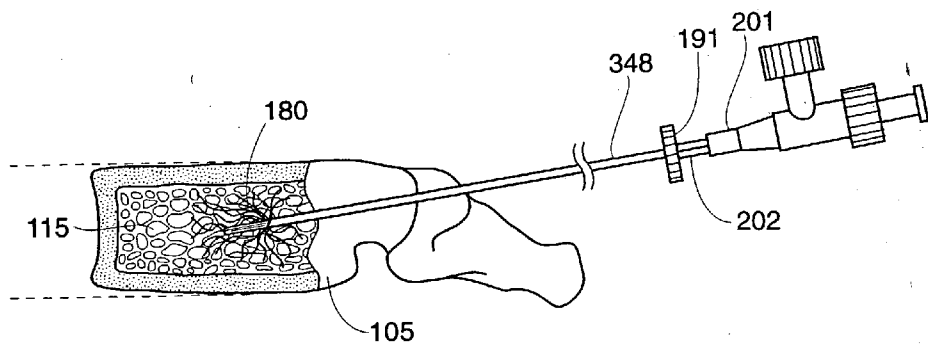

Fig. 16c

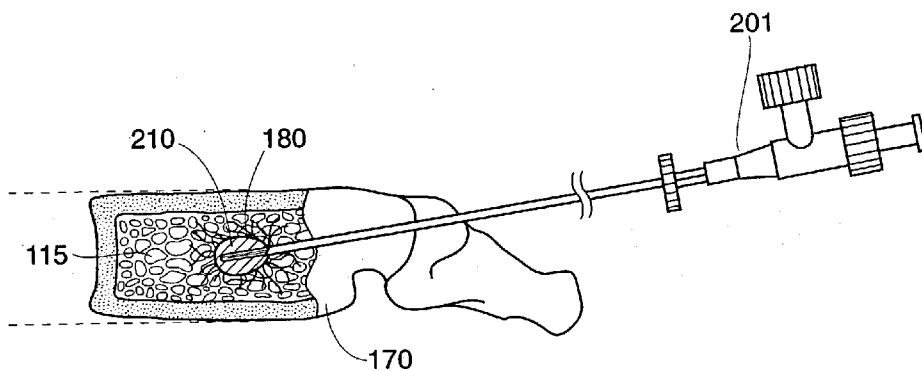
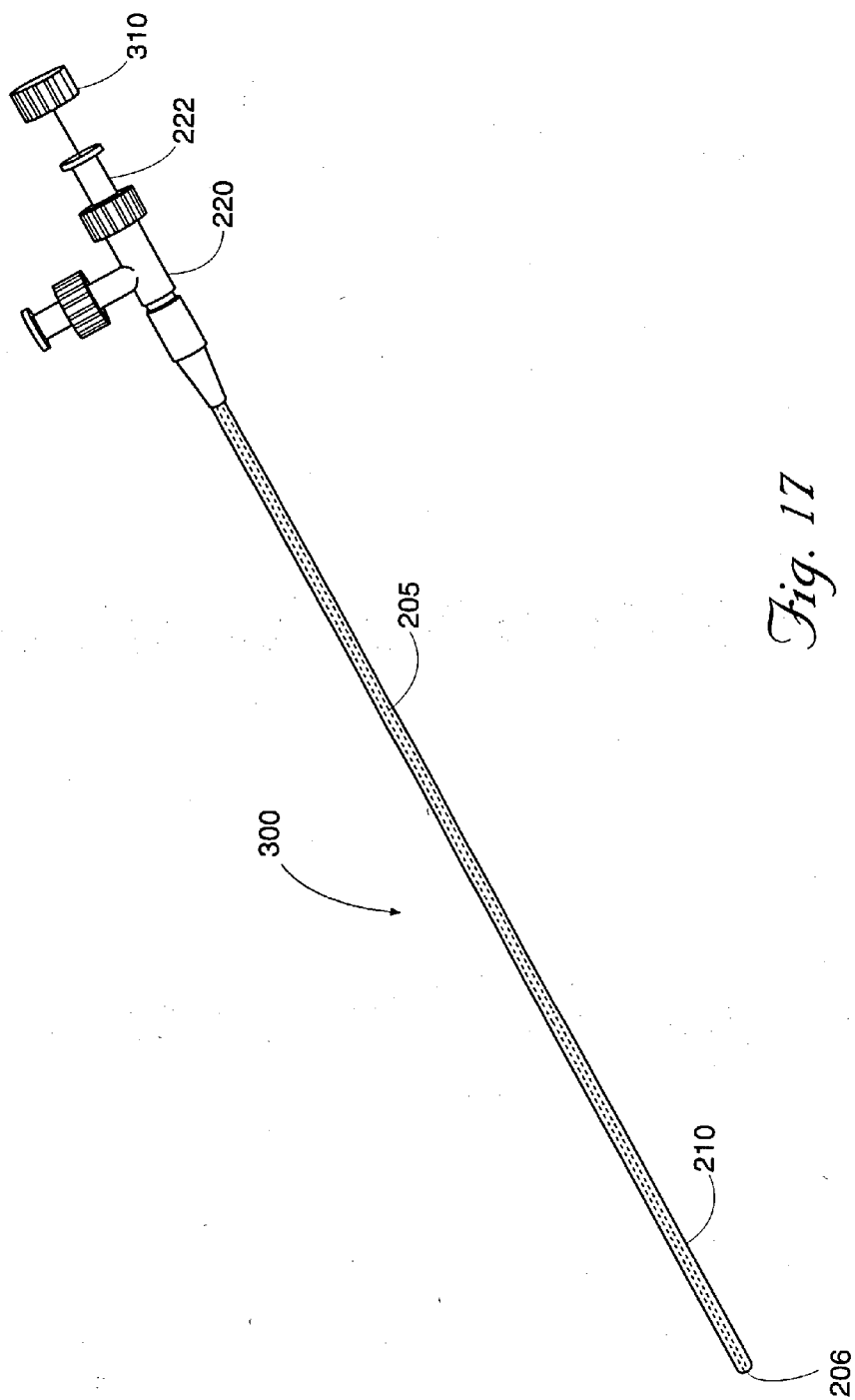

Fig. 16d



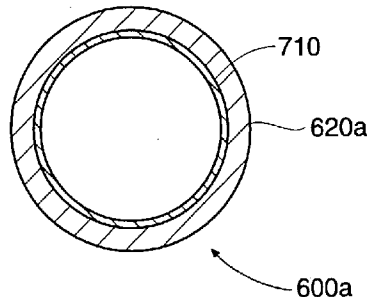

Fig. 19

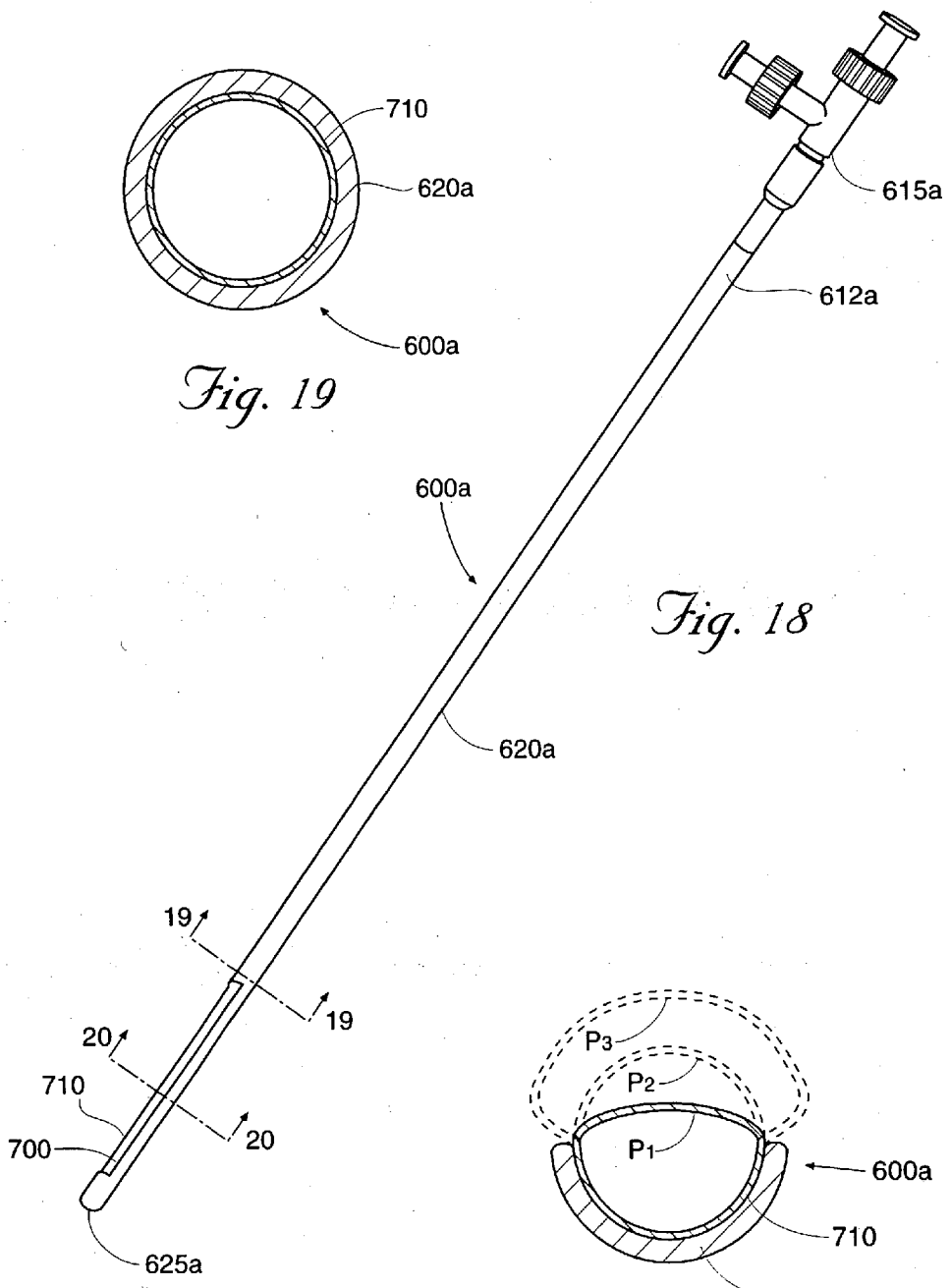

Fig. 18

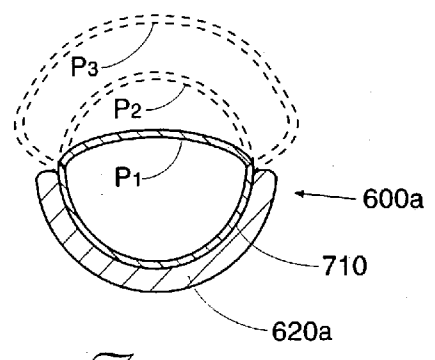

Fig. 20

METHODS AND DEVICES FOR TREATING BONE AFTER HIGH VELOCITY AND/OR TRAUMA FRACTURE

RELATED APPLICATIONS

[0001] This application claims the benefit of co-pending U.S. patent application Ser. No. 09/827,260 filed Apr. 5, 2001 and entitled "Methods and Devices for Treating Fractured and/or Diseased Bone, which is incorporated herein by reference and which itself claims the benefit of United States Provisional Patent Application Serial No. 60/194,685, now closed.

BACKGROUND OF THE INVENTION

[0002] 1. Field of the Invention

[0003] The present invention relates to devices and methods for treating fractured and/or diseased bone. More specifically, the present invention relates to devices and methods for repairing, reinforcing and/or treating fractured and/or diseased bone using various devices, including cavity-forming devices.

[0004] 2. Description of the Background

[0005] Normal healthy bone is composed of a framework made of proteins, collagen and calcium salts. Healthy bone is typically strong enough to withstand the various stresses experienced by an individual during his or her normal daily activities, and can normally withstand much greater stresses for varying lengths of time before failing. However, osteoporosis or a host of other diseases, including such diseases as breast cancer, hemangiomas, osteolytic metastases or spinal myeloma lesions, as well as the long term excessive use of alcohol, tobacco and/or various drugs, can affect and significantly weaken healthy bone over time. If unchecked, such factors can degrade bone strength to a point where the bone is especially prone to fracture, collapse and/or is unable to withstand even normal daily stresses.

[0006] Unfortunately, losses in bone strength are often difficult to discover until bone integrity has already been seriously compromised. For instance, the effects of osteoporosis are often not discovered until after a bone fracture has already occurred, at which time much of the patient's overall bone strength has typically weakened to dangerous levels. Moreover, as most bone development occurs primarily during childhood and early adulthood, long-term losses in bone strength are typically irreversible. In addition, many bone diseases, including osteoporosis, cancer, and other bone-related disorders, are not routinely curable at our current stage of medical development.

[0007] For many individuals in our aging world population, undiagnosed and/or untreatable bone strength losses have already weakened these individuals' bones to a point that even normal daily activities pose a significant threat of fracture. For example, when the bones of the spine are sufficiently weakened, the compressive forces in the spine can often cause fracture and/or deformation of the vertebral bodies. For sufficiently weakened bone, even normal daily activities like walking down steps or carrying groceries can cause a collapse of one or more spinal bones, much like a piece of chalk collapses under the compressive weight of a human foot. A fracture of the vertebral body in this manner is typically referred to as a vertebral compression fracture. Researchers

estimate that at least 25 percent of all women, and a somewhat smaller percentage of men, over the age of 50 will suffer one or more vertebral compression fractures due to osteoporosis alone. In the United States, it is estimated that over 700,000 vertebral compression fractures occur each year, over 200,000 of which require some form of hospitalization. Other commonly occurring fractures resulting from weakened bones can include hip, wrist, knee and ankle fractures, to name a few.

[0008] Fractures such as vertebral compression fractures often result in episodes of pain that are chronic and intense. Aside from the pain caused by the fracture itself, the involvement of the spinal column can result in pinched and/or damaged nerves, causing paralysis, loss of function, and intense pain which radiates throughout the patient's body. Even where nerves are not affected, however, the intense pain associated with all types of fractures is debilitating, resulting in a great deal of stress, impaired mobility and other long-term consequences. For example, progressive spinal fractures can, over time, cause serious deformation of the spine ("kyphosis"), giving an individual a hunched-back appearance, and can also result in significantly reduced lung capacity and increased mortality.

[0009] Until recently, treatment options for vertebral compression fractures, as well as other serious fractures and/or losses in bone strength, were extremely limited—mainly pain management with strong oral or intravenous medications, reduced activity, bracing and/or radiation therapy, all with mediocre results. Because patients with these problems are typically older, and often suffer from various other significant health complications, many of these individuals are unable to tolerate invasive surgery. In addition, to curb further loss of bone strength, many patients are given hormones and/or vitamin/mineral supplements—again with mediocre results and often with significant side effects.

[0010] Over the past decade, a technique called vertebroplasty has been introduced into the United States. Vertebroplasty involves the injection of a flowable reinforcing material, usually polymethylmethacrylate (PMMA—commonly known as bone cement), into a fractured, weakened, or diseased vertebral body. Shortly after injection, the liquid filling material hardens or polymerizes, desirably supporting the vertebral body internally, alleviating pain and preventing further collapse of the injected vertebral body.

[0011] While vertebroplasty has been shown to reduce some pain associated with vertebral compression fractures, this procedure has certain inherent drawbacks. The most significant danger associated with vertebroplasty is the inability of the practitioner to control the flow of liquid bone cement during injection into a vertebral body. Although the location and flow patterns of the cement can be monitored by CT scanning or x-ray fluoroscopy, once the liquid cement exits the injection needle, it naturally follows the path of least resistance within the bone, which is often through the cracks and/or gaps in the cancellous and/or cortical bone. Moreover, because the cancellous bone resists the injection of the bone cement and small diameter needles are typically used in vertebroplasty procedures, extremely high pressures are required to force the bone cement through the needle and into the vertebral body. Bone cement, which is viscous, is difficult to inject through small diameter needles, and thus many practitioners choose to "thin out" the cement mixture to improve

cement injection, which ultimately exacerbates the leakage problems. In a recent study where 37 patients with bone metastases or multiple myeloma were treated with vertebroplasty, 72.5% of the procedures resulted in leakage of the cement outside the vertebral body. Cortet B. et al., Percutaneous Vertebroplasty in Patients With Osteolytic Metastases or Multiple Myeloma (1998). Moreover, where the practitioner attempts to “thin out” the cement by adding additional liquid monomer to the cement mix, the amount of unpolymerized or “free” monomer increases, which can ultimately be toxic to the patient.

[0012] Another drawback of vertebroplasty is due to the inability to visualize (using CT scanning or x-ray fluoroscopy) the various venous and other soft tissue structures existent within the vertebra. While the position of the needle within the vertebral body is typically visualized, the location of the venous structures within the vertebral body are not. Accordingly, a small diameter vertebroplasty needle can easily be accidentally positioned within a vein in the vertebral body, and liquid cement pumped directly into the venous system, where the cement easily passes out the anterior and/or posterior walls of the vertebrae through the anterior external venous plexus or the basivertebral vein.

[0013] Another significant drawback inherent in vertebroplasty is the inability of this procedure to restore the vertebral body to a pre-fractured condition prior to the injection of the reinforcing material. Because the bone is fractured and/or deformed, and not repositioned prior to the injection of cement, vertebroplasty essentially “freezes” the bone in its fractured condition. Moreover, it is highly unlikely that a traditional vertebroplasty procedure could be capable of restoring significant pre-fracture anatomy—because bone cement flows towards the path of least resistance, any en-masse movement of the cortical bone would likely create gaps in the interior and/or walls of the vertebral body through which the bone cement would then immediately flow.

[0014] A more recently developed procedure for treating fractures such as vertebral compression fractures and other bone-related disorders is known as Kyphoplasty™. See, for example, U.S. Pat. Nos. 4,969,888 and 5,108,404. In Kyphoplasty, an expandable body is inserted through a small opening in the fractured or weakened bone, and then expanded within the bone. This procedure compresses the cancellous bone, and desirably moves the fractured bone to its pre-fractured orientation, creating a cavity within the bone that can be filled with a settable material such as cement or any number of synthetic bone substitutes. In effect, the procedure “sets” the bone at or near its pre-fracture position and creates an internal “cast,” protecting the bone from further fracture and/or collapse. This procedure is of course suitable for use in various other bones as well.

[0015] While Kyphoplasty can restore bones to a pre-fractured condition, and injected bone filler is less likely to leak out of the vertebral body during a Kyphoplasty procedure, Kyphoplasty requires a greater number of surgical tools than a vertebroplasty procedure, at an increased cost. Moreover, Kyphoplasty tools are typically larger in diameter than vertebroplasty tools, and thus require larger incisions and are generally more invasive.

SUMMARY OF THE INVENTION

[0016] The present invention overcomes many of the problems and disadvantages associated with current strategies and

designs in medical procedures to repair, reinforce and/or treat weakened, diseased and/or fractured bone. In one preferred embodiment, the present invention relates to improved vertebroplasty procedures and surgical instruments which facilitate such procedures. The technical features of the invention are well suited not only for the treatment of bone that is diseased or that has been otherwise weakened, but also for the treatment of bone that has been subjected to high velocity and/or trauma fracture.

[0017] In a general embodiment of the method of the present invention for the treatment of bone that has been subject to high velocity and/or trauma fracture, an insertion device, which can be, e.g., an eleven gauge spinal needle assembly, is inserted into a targeted vertebral body using fluoroscopic x-ray to monitor the positioning of the needle. A cavity-forming device is inserted through the insertion device into the vertebral body. The cavity-forming device desirably compresses cancellous bone in the vicinity of the distal tip of the insertion device—forming a small cavity within the bone. The cavity-forming device is removed and a bone filler is introduced through the insertion device. In the treatment of bone that has been subject to high velocity and/or trauma fracture, the bone filler is desirably a resorbable or remodelable material such as calcium phosphate or a material that includes calcium phosphate or similar material. The bone filler is desirably mixed with a fluoroscopic agent and is injected into the cavity using x-ray fluoroscopy to monitor the flow of the bone filler within the vertebral body. Bone filler introduction is halted when a desired fill amount is reached, the fractured portions of the vertebral body approach and/or return to their pre-fractured position, or bone filler leakage is imminent. Because a cavity is created within the vertebral body prior to bone filler introduction, very low injection pressures can be used, significantly reducing the possibility of cement leakage. In addition, the creation of desired flow paths permits a greater control in the placement of the bone filler material within the vertebral body.

[0018] In another general embodiment of a method of the present invention for the treatment of bone that has been subject to high velocity and/or trauma fracture, an insertion device, such as a commercially available spinal needle assembly, is inserted through a cortical bone region and into a cancellous bone region of a targeted bone using fluoroscopic x-ray to monitor the positioning of the needle. A first material, e.g., a bone filler such as calcium phosphate or a material that includes calcium phosphate or similar material, is introduced into the cancellous bone region through the insertion device. An expandable structure is then inserted through the insertion device and expanded in the bone, compressing the first material and/or cancellous bone, thereby creating a cavity and/or a barrier region of compressed cancellous bone substantially surrounding the cavity. A second material, which may be of the same material as the first material, is then introduced through the insertion device into the bone. If desired, the first material can comprise a material having sufficient strength to support the cavity during the surgical procedure, thereby preventing collapse of the cavity upon contraction and removal of the expandable structure. Such first material could include, but is not limited to, bone cement, bone graft material or metallic and nonmetallic stents.

[0019] In a further embodiment, the methods of the present invention are performed on a vertebra that has been subject to high velocity and/or trauma fracture to strengthen the verte-

bra, returning it, at least partially, to its pre-fractured position, protect the vertebra from further fracture or collapse, and/or alleviate the pain associated with spinal fractures.

[0020] In one embodiment of the present invention, a cavity-forming device comprises a balloon catheter. The balloon catheter desirably incorporates a hollow tube which extends through a balloon material. At the proximal end of the catheter, the tube and expandable structure are connected to a fitting. At the distal end, the expandable structure is secured directly to and/or around the hollow tube. The distal end of the expandable structure and the distal end of the hollow tube are sealed. Near the distal end of the hollow tube are one or more openings through which an inflation medium passes in and out of the hollow tube to expand and contract the expandable structure.

[0021] The balloon catheter of the present invention may be inserted through an insertion device, such as an eleven gauge needle assembly, into a bone, such as a vertebral body, with the distal end of the catheter extending beyond the needle to a length determined by the physician. When the catheter is filled with an inflation medium, the portion of the catheter extending beyond the needle expands outward, compressing cancellous bone and forming a desired cavity within the vertebral body.

[0022] In another embodiment of the present invention, the cavity-forming device comprises a shaft incorporating one or more wires or "bristles" at the distal end. The cavity-forming device is desirably inserted through an insertion device, such as a spinal needle, into a cancellous region of a bone, such as a vertebral body. As the bristles enter the vertebral body, they displace cancellous bone in a controlled manner, creating one or more small pathways or cavities in the cancellous bone. The cavity-forming device is removed from the vertebral body and needle, and bone filler is introduced into the vertebral body. The bone filler, which normally flows towards the path of least resistance, will initially flow through the small cavities. If desired, the physician can interrupt introduction of bone filler and create additional cavities by reinserting the cavity-forming device. By creating desired pathways through cancellous bone, the present invention reduces opportunities for leakage of bone filler outside of the vertebral body and/or improves distribution of bone filler through a significant portion of the vertebral body.

[0023] Other objects, advantages, and embodiments of the invention are set forth in part in the description which follows, and in part, will be obvious from this description, or may be learned from the practice of the invention.

BRIEF DESCRIPTION OF THE DRAWINGS

[0024] FIG. 1 is a diagram of a spine with a compression fracture in one vertebrae;

[0025] FIG. 2 is a diagram of a patient about to undergo surgery;

[0026] FIG. 3 is a lateral view, partially broken away and in section, of a lumbar vertebra depicting a compression fracture;

[0027] FIG. 4 is a coronal view of a lumbar vertebra;

[0028] FIG. 5A is a lateral view of a lumbar vertebra depicting a spinal needle inserted into the vertebral body;

[0029] FIG. 5B is a lateral view of the lumbar vertebra of FIG. 5A, with the stylet removed from the spinal needle;

[0030] FIG. 5C is a lateral view of the lumbar vertebra of FIG. 5B, with a cavity-forming device constructed in accordance with one embodiment of the present invention inserted into the vertebral body;

[0031] FIG. 5D is a lateral view of the lumbar vertebra of FIG. 5C, with the cavity-forming device inflated;

[0032] FIG. 5E is a lateral view of the lumbar vertebra of FIG. 5D, with the cavity-forming device deflated;

[0033] FIG. 5F is a lateral view of the lumbar vertebra of FIG. 5E, with the cavity-forming device removed from the vertebral body;

[0034] FIG. 5G is a lateral view of the lumbar vertebra of FIG. 5F, with a bone filler injected into the vertebral body;

[0035] FIG. 5H is a lateral view of the lumbar vertebra of FIG. 5G, with the spinal needle advanced into the cavity;

[0036] FIG. 5I is a lateral view of the lumbar vertebra of FIG. 5H, with a second bone filler injected into the vertebral body;

[0037] FIG. 5J is a lateral view of the lumbar vertebra of FIG. 5I, with additional bone filler injected into the vertebral body;

[0038] FIG. 5K is a lateral view of the lumbar vertebra of FIG. 5J, with additional bone filler injected into the vertebral body;

[0039] FIG. 5L is a lateral view of the lumbar vertebra of FIG. 5K, with the spinal needle removed from vertebral body;

[0040] FIG. 6A is a side view of a cavity-forming device constructed in accordance with an alternate embodiment of the present invention;

[0041] FIG. 6B is a close-up view of the distal end of the cavity-forming device of FIG. 6A;

[0042] FIG. 7A is a lateral view of a lumbar vertebra, depicting the cavity-forming device of FIG. 6A being inserted into the vertebra;

[0043] FIG. 7B is a lateral view of the lumbar vertebra of FIG. 7A, with the cavity-forming device deployed within the vertebra;

[0044] FIG. 7C is a lateral view of the lumbar vertebra of FIG. 7B, with the cavity-forming device withdrawn from the vertebra;

[0045] FIG. 8A is a lateral view of a lumbar vertebra, depicting an alternate procedure for treating a vertebral body in accordance with the teachings of the present invention;

[0046] FIG. 8B is a lateral view of the lumbar vertebra of FIG. 8A, with a cavity-forming device inserted into the bone filler;

[0047] FIG. 8C is a lateral view of the lumbar vertebra of FIG. 8B, with the cavity-forming device expanded in the cavity;

[0048] FIG. 9 is a side view of a cavity-forming device constructed in accordance with one embodiment of the present invention;

[0049] FIG. 10 is a close-up view of the distal end of a cavity-forming device of FIG. 9;

[0050] FIG. 11 is a close-up view of the distal end of a balloon catheter protruding from the distal end of a needle, depicting the inflation of the balloon material with an inflation medium;

[0051] FIG. 12 is a side view of a cavity-forming device constructed in accordance with an alternate embodiment of the present invention;

[0052] FIG. 13 is a side view of a cavity-forming device constructed in accordance with another alternate embodiment of the present invention;

[0053] FIG. 14 is a side view of a cavity-forming device constructed in accordance with another alternate embodiment of the present invention;

[0054] FIG. 15 is a side view of a cavity-forming device constructed in accordance with another alternate embodiment of the present invention;

[0055] FIG. 16A is a lateral view of a lumbar vertebra, depicting an alternate procedure for treating a vertebral body in accordance with the teachings of the present invention;

[0056] FIG. 16B is a lateral view of the lumbar vertebra of FIG. 16A, with bone filler injected into the vertebra;

[0057] FIG. 16C is a lateral view of the lumbar vertebra of FIG. 16B, with a cavity-forming device inserted into the vertebra;

[0058] FIG. 16D is a lateral view of the lumbar vertebra of FIG. 16C, with the cavity-forming device expanded in the cavity;

[0059] FIG. 17 is a side view of a cavity-forming device constructed in accordance with another alternate embodiment of the present invention;

[0060] FIG. 18 is a side view of a cavity-forming device constructed in accordance with another alternate embodiment of the present invention;

[0061] FIG. 19 is a cross-sectional view of the cavity-forming device of FIG. 18, taken along line 19-19; and

[0062] FIG. 20 is a cross-sectional view of the cavity-forming device of FIG. 18, taken along line 20-20.

DESCRIPTION OF THE INVENTION

[0063] As embodied and broadly described herein, the present invention is directed to surgical methods for repairing, reinforcing and/or treating weakened, diseased and/or fractured bone. The technical features of the invention are well suited not only for the treatment of bone that is diseased or that has been otherwise weakened, but also for the treatment of bone that has been subjected to high velocity and/or trauma fracture. The present invention is further directed to various devices for facilitating such surgical methods.

[0064] FIG. 1 depicts a typical human spine 1, in which a compression fracture 10 has occurred in a lumbar vertebra 100. As best shown in FIG. 3, vertebra 100 has fractured, with the top and bottom plates 103 and 104 depressing generally towards the anterior wall 10 of the vertebra 100 and away from their pre-fracture, normally parallel orientation (indicated generally as parallel lines 90).

[0065] FIG. 4 depicts a coronal (top) view of the vertebra of FIG. 3. Vertebra 100 includes a vertebral body 105, which extends on the anterior (i.e. front or chest) side of the vertebra 100. Vertebral body 105 is approximately the shape of an oval disk, with an anterior wall 10 and a posterior wall 261. The geometry of the vertebral body 105 is generally symmetric. Vertebral body 105 includes an exterior formed from compact cortical bone 110. The cortical bone 110 encloses an interior volume of reticulated cancellous, or spongy, bone 115 (also called medullar bone or trabecular bone).

[0066] The spinal canal 150 is located on the posterior (i.e. back) side of each vertebra 100. The spinal cord 151 passes through the spinal canal 150. A vertebral arch 135 surrounds the spinal canal 150. Left and right pedicles 120 of the vertebral arch 135 adjoin the vertebral body 105. The spinous process 130 extends from the posterior of the vertebral arch 135, as do the left and right transverse processes 125 and the mamillary processes 126.

[0067] FIG. 2 depicts a patient 50 prepared for disclosed methods of the present invention. These procedures can be performed on an outpatient or inpatient basis by a medical professional properly trained and qualified to perform the disclosed procedures. Desirably, the patient will be placed under general or local anesthetic for the duration of the surgical procedures.

[0068] In one embodiment of the present invention, a surgical method comprises inserting an insertion device 350 (see FIG. 5A) percutaneously into the bone, such as a fractured vertebral body 105 through, preferably, a targeted area of the back, depicted as 60 in FIG. 2. The insertion device 350 may be any type and size of hollow instrument, preferably having a sharp end. In one preferred embodiment, the insertion device 350 comprises a hollow needle of approximately eleven gauge diameter. An eleven gauge needle is preferred for the procedure because it incorporates a hollow lumen of sufficient size to permit the passage of various instruments and materials, yet the overall size of the needle is small enough to minimize bone and tissue damage in the patient. It should be understood, however, that various other size needle assemblies, including needles of six to 14 gage, could be used with the devices and methods of the present invention, with varying results. In addition, various other access instruments, such as those described in U.S. Pat. Nos. 4,969,888, 5,108,404, 5,827,289, 5,972,015, 6,048,346 and 6,066,154, each of which are incorporated herein by reference, could be used in accordance with the teachings of the present invention, with varying results.

[0069] The insertion device 350 is preferably comprised of a strong, non-reactive, and medical grade material such as surgical steel. If desired, the insertion device 350 is attached to a manipulating assembly which is comprised of a non-reactive and medical grade material including, but not limited to, acrylonitrile-butadiene-styrene (ABS), polyethylene, polypropylene, polyurethane, Teflon, or surgical steel. FIG. 5A depicts a commercially available needle assembly typically used with various embodiments of the present invention, which are further described below.

[0070] As shown in FIG. 5A, an insertion device 350, such as an eleven gauge biopsy needle (commercially available from Becton Dickinson & Co of Franklin Lakes, N.J.) can be inserted through soft tissues of the back and into the vertebral body 105. Generally, the approach for such a procedure will

be transpedicular, although various other approaches, including lateral, extrapedicular and/or anterior approaches, could be used, depending upon the level treated and/or intervening anatomical features well known to those of ordinary skill in the art. In one embodiment, the device **350** comprises a needle body **348** and a stylet **349**, as is well known in the art. During insertion of the device **350**, the location of the device **350** is desirably monitored using visualization equipment such as real-time X-Ray, CT scanning equipment **70** (see FIG. 2), MRI, or any other monitoring equipment commonly used by those of skill in the art, including computer aided guidance and mapping equipment such as the systems commercially available from BrainLab Corporation or General Electric Corporation.

[0071] In one preferred embodiment, the distal end **351** of the insertion device **350** is positioned in the vertebral body **105**, preferably at a location towards the posterior side of the vertebral body **105**. If desired, the distal end **351** could be positioned in various locations throughout the vertebral body **105**, including towards the anterior side. Once in position, the stylet **349** of the insertion device **350** may be removed, see FIG. 5B, and a cavity-forming device **200** may be inserted through the shaft **348** and into the vertebral body **105**. See FIG. 5C. The cavity-forming device **200**, which is desirably comprised of a biologically compatible and medically acceptable material, can be a small mechanical tamp, reamer, hole punch, balloon catheter (as described below) or any appropriate device which is capable of displacing cancellous bone. Once the cavity-forming device is positioned within the vertebral body **105**, it is used to displace cancellous bone **115**, thereby creating a cavity **170**. See FIG. 5F.

[0072] In one embodiment, shown in FIGS. 9 and 10, the cavity-forming device comprises a balloon catheter **200**. The balloon catheter **200** desirably extends across at least 20% of the vertebral body, but could extend greater or lesser amounts, depending upon the desired size of the cavity to be produced. In this embodiment, as the balloon catheter **201** is expanded, cancellous bone is displaced generally outward from the cavity **170** in a controlled manner, desirably forming a compressed-bone region **172** around a substantial portion of the outer periphery of the cavity **170**.

[0073] The balloon catheter **200**, which will be described in more detail below, is sized or folded to fit through the hollow interior of the shaft **348** and into a vertebral body **105**. Once in a desired, position within the vertebral body **105**, the balloon catheter **190** is filled with a pressurized filling medium **275** appropriate for use in medical applications including, but not limited to, air, nitrogen, saline or water. See FIGS. 5D and 11. In a preferred embodiment, the filling medium **275** is a radiopaque fluid (such as Conray® fluid available commercially from Mallinckrodt, Inc., of St. Louis, Mo.), which allows the physician to visualize the catheter **190** during inflation. If desired, alternate ways of expanding the catheter, including mechanical expanders, jacks, expanding springs and/or expanding/foaming agents, could be used, with varying results.

[0074] In one embodiment, the catheter **201** is expanded to any appropriate volume which creates a cavity **170** within the vertebral body **105**. In a preferred embodiment, the catheter **201** is expanded to at least 0.20 cc in volume, but could be expanded to significantly greater sizes, such as 1, 2, 4, 6 or 8 cc, depending upon bone quality and density. After cavity

creation, the catheter **201** is deflated (see FIG. 5E) and removed from the vertebral body **105** and shaft **348** (see FIG. 5F). Bone filler **180** is introduced through the shaft **348** and into the vertebral body **105** using any type of plunger, extruder and/or feed line assembly **349** compatible with the needle body **348**. Once injection of bone filler is complete, the shaft **348** can be withdrawn.

[0075] If desired, a portion of the balloon catheter **201** could be temporarily or permanently left within a vertebral body **105**. For example, after cavity formation and removal of the inflation medium, the deflated expanded section of the balloon catheter **201** could be refilled with bone filler **180** and left within the vertebral body **105**. Alternatively, the inflation medium **275** could comprise bone filler **180**. After the balloon catheter **201** is filled with such an inflation medium, at least a portion of the catheter **201** could be left permanently within the cavity **170**. In an alternate embodiment, the catheter **201** which is intended to remain with the cavity **170** could comprise a bio-absorbable material and/or fabric/mesh material as the expandable structure.

[0076] In creating the cavity **170**, the inflation of the catheter **201** causes the expandable material **210** to press against the cancellous bone **115** which may form a compressed bone region or "shell" **172** along much of the periphery of the cavity **170**. This shell **172** will desirably inhibit or prevent bone filler **180** from exiting the cavity **170**, thereby inhibiting extravasation of the bone filler and/or facilitating pressurization of the bone filler **180**, if desired, within the cavity. As the pressure in the cavity **170** increases, the walls of the cavity **170** will desirably be forced further outward by the bone filler **180**, compressing additional cancellous bone within the vertebral body **105** and/or increasing the size of the cavity **170**. If sufficient pressure is available, and integrity of the shell **172** can be maintained without significant leakage of bone filler **180**, pressures capable of moving fractured cortical bone can be developed.

[0077] In one embodiment of the present invention, after cavity formation, an amount of a material, such as a bone filler **180**, is introduced through the shaft **348** into the vertebral body **105** under low pressure. The amount of bone filler will desirably be more than the volume of the cavity **170**, however, less bone filler may be introduced with varying results. Once the cavity **170** is substantially filled, the continued introduction of bone filler **180** will desirably pressurize the bone filler **180** in the cavity **170** such that the increased pressure will cause at least a portion of the walls of the cavity to move outward, thereby enlarging the cavity **170** and further compressing cancellous bone and/or moving cortical bone. Desirably, introduction of the bone filler **180** will continue until bone filler leak from the vertebral body appears imminent, the cortical bone has regained its pre-fractured position and/or the practitioner determines that sufficient bone filler **180** has been injected into the bone. If desired, the physician can utilize the cavity-forming device to create additional cavities for bone filler, or the shaft **348** can be removed from the vertebral body to completed the procedure.

[0078] The bone filler **180** could be any appropriate filling material used in orthopedic surgery, including, but not limited to, allograft or autograft tissue, hydroxyapatite, epoxy, PMMA bone cement, or synthetic bone substitutes such as Osteoset® from Wright Medical Technology, medical grade plaster of paris, Skeletal Repair System (SRS®) cement from Norian Corporation, or Collagraft from Zimmer.

[0079] In the treatment of bone that has been subject to high velocity and/or trauma fracture, the bone filler is desirably a resorbable or remodelable material such as calcium phosphate or a material that includes calcium phosphate or similar material. An example of such a material is NORIEN SRS™ calcium phosphate.

[0080] As bone filler 180 is introduced into the vertebral body 105, the introduction is desirably monitored by x-ray fluoroscopy, or any other appropriate monitoring device or method, to ensure that bone filler 180 does not flow outside of the vertebral body 105. To facilitate visualization, the bone filler 180 may be mixed with a fluoroscopic agent, such as radio opaque barium sulfate. In another embodiment, the bone filler 180 could comprise a mixture of bone cement and a thixotropic material which desirably limits and/or prevents extravazation of the bone cement.

[0081] In an alternate embodiment of the disclosed method, shown in FIGS. 5G through 5L, a first bone filler 180 is introduced into the cavity 170, the amount of first bone filler 180 being desirably less than or approximately equal to the volume of the cavity 170. For example, if the balloon catheter 200 utilized to create the cavity 170 was inflated with 1.0 cc of inflation fluid, then less than or approximately 1.0 cc of bone filler 180 will initially be injected into the cavity 170. Of course, if desired, an amount of first bone filler 180 greater than the cavity volume could be injected into the cavity. The shaft 348 is then repositioned within the vertebral body 105, see FIG. 5H, with the distal end 351 of the device 350 desirably located within the bolus 400 of first bone filler 180 contained in the cavity 170. As best shown in FIG. 5I, a second amount of bone filler 182 is then injected into the vertebral body 105, which desirably forces the first amount of bone filler 180 outward against the walls of the cavity 170. Desirably, the first amount of bone filler 180 will resist extravazating out of the cavity 170 and will push outward against the walls of the cavity 170, further compressing the cancellous bone 115 and/or increasing the size of the cavity 170. Introduction of the second amount of bone filler 182 will desirably continue until bone filler leak from the vertebral body appears imminent, the cortical bone has regained its pre-fractured position, and/or the practitioner determines that sufficient bone filler 180 has been injected into the bone. If desired, the physician could reinsert a catheter 200 to create an additional cavity, or the shaft 348 can be removed to complete the procedure.

[0082] FIGS. 8A through 8C depict an alternate embodiment of the disclosed method, in which the practitioner introduces a first material, such as a bone filler 180, into the cavity 170, and subsequently inserts a cavity-forming device 200 into the bone. The cavity-forming device 200 is then expanded, and desirably compresses the bone filler 180 against the walls of the cavity, sealing any significant cracks and/or venous passages through which the cement will flow. In one further embodiment, a practitioner may wait to allow the first bone filler to harden partially or fully prior to removing the cavity-forming device and/or prior to introducing a second material, such as a bone filler. The second material (not shown) can subsequently be injected into the vertebral body with little fear of leakage. If desired, this method could be utilized whenever cement leakage appears imminent, and can be repeated multiple times until the practitioner determines that sufficient bone filler 180 has been injected into the bone. In addition, the practitioner could repeat this procedure

until the cortical bone has regained its pre-fractured position. In an alternate embodiment, the practitioner could utilize a cavity-forming device prior to the introduction of the first bone filler, and then introduce the first bone filler into the cavity, subsequently follow one or more of the described methods.

[0083] The first bone filler will desirably comprise a material that can be introduced into the cavity, but which will resist extravazation out of the cavity and/or vertebral body when the second bone filler is injected into the cavity.

[0084] In one embodiment of the invention, the first and second bone fillers comprise bone cement, with the first bone cement being more resistant to extravazation than the second bone cement. For example, the ingredients of the first bone cement could be specifically tailored such that the first bone cement cures faster than the second bone cement. Alternatively, the first bone cement could be prepared and/or introduced into the vertebral body before the second bone cement, allowing the first bone cement to partially or fully cure before the second bone cement. Alternatively, the curing and/or hardening of the first bone cement could be accelerated (by applying heat, for example) or curing and/or hardening of the second bone cement could be retarded (by cooling, for example). In another embodiment, the first and second bone fillers comprise bone cement, with the first bone cement desirably being more viscous than the second bone cement. In another alternate embodiment, the first bone filler comprises an expandable structure, such as a stent.

[0085] In another embodiment, the first bone filler comprises a material more viscous than the second bone filler, the first and second bone fillers comprising different materials. In another embodiment, the first bone filler comprises a material which is more resistant to extravazation into the cancellous bone than the second bone filler. In another embodiment, the first bone filler comprises a material having particles generally larger than particles in the second bone filler. In a further embodiment, the particles of the first bone filler are generally larger than the average pore size within the cancellous bone. In another embodiment, the first bone filler comprises a settable material, such as a two-part polyurethane material or other curable biomaterial.

[0086] In the treatment of bone that has been subject to high velocity and/or trauma fracture, the first or second bone fillers, or both, is desirably a resorbable or remodelable material such as calcium phosphate or a material that includes calcium phosphate or similar material. An example of such a material is NORIEN SRS™ calcium phosphate.

[0087] FIGS. 16A through 16D depict an alternate embodiment of the disclosed method, in which a first material, such as a bone filler 180, is initially introduced into the cancellous bone 115 of a human bone, such as a vertebral body 105. An expandable structure 210, such as that found at the distal end of a balloon catheter 200, is subsequently inserted into the vertebral body 105. The expandable structure 210 is then expanded, which displaces the bone filler 180 and/or cancellous bone 115, creating a cavity 170 within the vertebral body 105. In one embodiment, the expansion of the expandable structure 210 forces the bone filler 180 further into the cancellous bone 115, and/or further compresses cancellous bone. To minimize bone filler 180 leakage, the bone filler may be allowed to partially or completely harden prior to expansion of the expandable structure 210. Alternatively, the expand-

able structure **210** may be expanded, and the bone filler **180** allowed to partially or completely harden around the expandable structure **210**. In either case, a second material, optionally additional bone filler, may be introduced into the cavity **170**. In one embodiment, the second material is a material which supports the bone in a resting position. This method may be utilized whenever bone filler leakage appears imminent, and may be repeated multiple times until the practitioner determines that sufficient amounts and varieties of material have been introduced into the bone. Alternatively, the practitioner could halt introduction of filler material when the cortical bone regains or approximates its pre-fractured position.

[0088] By creating cavities and/or preferred flowpaths within the cancellous bone, the present invention obviates the need for extremely high pressure injection of bone filler into the cancellous bone. If desired, the bone filler could be injected into the bone at or near atmospheric and/or ambient pressures, or at pressures less than approximately 400 pounds per square inch, using bone filler delivery systems such as those described in co-pending U.S. patent application Ser. No. 09/134,323, which is incorporated herein by reference. Thus, more viscous bone fillers (such as, for example, thicker bone cement) can be injected into the bone under low pressures (such as, for example, exiting the delivery device at a delivery pressure at or near ambient or atmospheric pressure), reducing opportunities for cement leakage and/or extravasation outside of the bone.

Cavity-Forming Devices

[0089] The present invention also includes cavity-forming devices constructed in accordance with the teachings of the disclosed invention. In one embodiment, the cavity-forming device comprises a balloon catheter **201**, as shown in FIGS. **9**, **10**, and **11**. The catheter comprises a hollow tube **205**, which is desirably comprised of a medical grade material such as plastic or stainless steel. The distal end **206** of the hollow tube **205** is surrounded by an expandable material **210** comprised of a flexible material such as commonly used for balloon catheters including, but not limited to, metal, plastics, composite materials, polyethylene, mylar, rubber or polyurethane. One or more openings **250** are disposed in the tube **205** near the, distal end **206**, desirably permitting fluid communication between the hollow interior of the tube **205** and the lumen formed between the tube **205** and the expandable structure **210**. A fitting **220**, having one or more inflation ports **222**, **224**, is secured to the proximal end **207** of the tube **205**. In this embodiment, once the catheter **201** is in its desired position within the vertebral body **105**, an inflation medium **275** is introduced into the fitting **220** through the inflation port **222**, where it travels through the fitting **220**, through the hollow tube **205**, through the opening(s) **250** and into the lumen **274** between the expandable structure **210** and the hollow tube **205**. As injection of the inflation medium **275** continues, the pressure of the inflation medium **275** forces the expandable structure **210** away from the hollow tube **205**, inflating it outward and thereby compressing cancellous bone **115** and forming a cavity **170**. Once a desired cavity size is reached, the inflation medium **275** is withdrawn from the catheter **200**, the expandable structure collapses within the cavity **170**, and the catheter **200** may be withdrawn.

[0090] For example, a balloon catheter **201** constructed in accordance with one preferred embodiment of the present invention, suitable for use with an 11-gauge needle, would

comprise a hollow stainless steel hypodermic tube **205**, having an outer diameter of 0.035 inches and a length of 10.75 inches. One or more openings **250** are formed approximately 0.25 inches from the distal end of the tube **205**. In a preferred embodiment, the distal end **206** of the hollow tube **205** is sealed closed using any means well known in the art, including adhesive.

[0091] In one embodiment, the hollow tube **205** is substantially surrounded by an expandable structure **210** comprising an extruded tube of polyurethane plastic. In one embodiment, the polyurethane tube has an inner diameter of 0.046 inches, an outer diameter of 0.082 inches, and a length of 9½ inches. The distal end of the polyurethane tube is bonded to the distal end **206** of the hollow tube **205** by means known in the art, such as by a suitable adhesive. Alternatively, the polyurethane tube may be heat sealed about the distal end **206** of the hollow tube **205** by means well known in the art. A ¾ inch long piece of heat shrink tubing **215**, having a ⅜ inch outer diameter, may be secured around the proximal end of the polyurethane tubing. In one embodiment, the proximal end of the hollow tubing **205** is inserted into the fitting **220** and the heat shrink tubing **215** is desirably bonded into the fitting **220** using a suitable adhesive known in the art. The fitting **220**, which may be a Luer T-fitting, commercially available from numerous parts suppliers, may be made of any appropriate material known to those of skill in the art. The fitting **220** comprises one or more ports **222**, **224** for attachment to additional instruments, such as pumps and syringes (not shown). If desired, the hollow tube **205** can similarly be bonded into the fitting **220** using a suitable adhesive. Alternatively, as shown in FIG. **12**, the expandable structure **210** could be significantly shorter than the hollow tube **205** and be bonded at its distal end **206** and its proximal end **209** to the hollow tube **205**.

[0092] The hollow tube **205** and one or more openings **250** facilitate the withdrawal of inflation medium from the catheter during the disclosed procedures. When a catheter is deflated, the expandable structure **210** will normally collapse against the tube **205**, which can often seal closed the lumen (in the absence of at least one secondary withdrawal path) and inhibit further withdrawal of inflation medium from the expanded structure **210** of a catheter. However, in an embodiment of the disclosed invention, the one or more openings **250** near the distal end of the tube **205** allow inflation medium **275** to be drawn through the hollow hypodermic tube **205**, further deflating the expandable structure **210**. The strong walls of the hollow hypodermic tube **205** resist collapsing under the vacuum which evacuates the inflation medium, maintaining a flowpath for the inflation medium and allowing the inflation medium to be quickly drawn out of the catheter, which desirably permits deflation of the catheter in only a few seconds.

[0093] In the disclosed embodiment, as the catheter **201** is inflated, the inflation medium **275** will typically seek to fill the entire lumen between the expandable structure **210** and the hollow tube **205**, thus expanding the catheter **201** along the entire length of the expandable structure **210**. However, because much of the catheter **201** is located within the lumen of the shaft **348**, with the distal end **206** of the catheter **201** extending into the vertebral body **105**, the shaft **348** will desirably constrain expansion of the expandable structure **210**, causing the expandable structure **210** to expand primarily at the distal end **206** of the catheter **200**. Desirably, further insertion or withdrawal of the catheter **201** will alter the

amount of the expandable structure 210 extending from the distal end of the shaft 348, thereby increasing or decreasing the length of the expandable structure 210 that is free to expand within the vertebral body 105. By choosing the amount of catheter 201 to insert into the vertebral body 105, the practitioner can alter the length of the expandable structure, and ultimately the size of the cavity 170 created by the catheter 201, during the surgical procedure. Therefore, the disclosed embodiments can obviate and/or reduce the need for multiple catheters of varying lengths. If desired, markings 269 (see FIG. 9) can be placed along the proximal section of the catheter which correspond to the length of the catheter 201 extending from the shaft 348, allowing the practitioner to gauge the size of the expandable structure 210 of the catheter 200 within the vertebral body 105. Similarly, in an alternate embodiment as disclosed below, the cavity-forming device 201 could incorporate markings corresponding to the length of the bristles 425 extending beyond the tip of the shaft 348.

[0094] In an alternate embodiment, shown in FIG. 13, the length of an expandable section 211 of the catheter can be further constrained by securing and/or adhering the expandable structure 210 at a secondary location 214 along the hollow tube 205, thereby limiting expansion beyond the secondary location 214. For example, if a desired maximum length of the expandable section 211 were 3 inches, then the expandable structure 210 could be secured to the hollow tube 205 at a secondary location 214 approximately three inches from the distal end 206 of the hollow tube 205. This arrangement would desirably allow a practitioner to choose an expanded length of the expandable section 211 of up to three inches, while limiting and/or preventing expansion of the remaining section 203 of the catheter 201. This arrangement can also prevent unwanted expansion of the portion 202 of the catheter extending out of the proximal end 191 of the shaft body 348 (see FIG. 5C).

[0095] As previously noted, in the disclosed embodiment, the expandable structure is desirably secured to the distal end of the hollow tube, which will facilitate recovery of fragments of the expandable structure 210 if the expandable structure 210 is torn or damaged, such as by a complete radial tear. Because the hollow tube 205 will desirably remain attached to the fragments (not shown) of the expandable structure 210, these fragments can be withdrawn from the vertebral body 105 with the hollow tube 205. In addition, the distal attachment will desirably prevent and/or reduce significant expansion of the expandable structure 210 along the longitudinal axis of the hollow tube 205.

[0096] FIG. 17 depicts a cavity-forming device 300 constructed in accordance with an alternate embodiment of the present invention. Because many of the features of this embodiment are similar to embodiments previously described, like reference numerals will be used to denote like components. In this embodiment, the hollow tube 205 extends through the fitting 220, such as a t-shaped fitting, and is secured to a cap 310. In a preferred embodiment, the hollow tube 205 is capable of rotation relative to the fitting 220. If desired, a seal (not shown), such as a silicone or teflon o-ring, can be incorporated into the proximal fitting 222 to limit and/or prevent leakage of inflation medium past the hollow tube 205.

[0097] In use, a cavity-forming device 300 compresses cancellous bone and/or forms a cavity in a manner similar to the

embodiments previously described. However, once the cavity is formed and withdrawal of the device 300 is desired, the cap 310 can be rotated, twisting the expandable material 210 relative to the fitting 220 and drawing the expandable structure 210 against the hollow tube 205, desirably minimizing the overall outside diameter of the expandable portion of the device 300. The device 300 can then easily be withdrawn through the shaft 348. Even where the expandable structure 210 has plastically deformed, or has failed in some manner, the present embodiment allows the expandable structure 210 to be wrapped around the hollow tube 205 for ease of withdrawal and/or insertion. Alternatively, the hollow tube 205 may be capable of movement relative to the longitudinal axis of the fitting 220, which would further stretch and/or contract the expandable structure 210 against the hollow tube 205.

[0098] FIGS. 6A and 6B depict a cavity-forming device 410 constructed in accordance with an alternate embodiment of the present invention. Cavity-forming device 410 comprises a shaft 420 which is desirably sized to pass through the shaft 348 of an insertion device 350. A handle assembly 415, which facilitates manipulation of the cavity-forming device 410, is secured to the proximal end 412 of the shaft 420. One or more wires or "bristles" 425 are secured to the distal end 423 of the shaft 420. The bristles 425 can be secured to the shaft 420 by welding, soldering, adhesives or other securing means well known in the art. Alternatively, the bristle(s) 425 can be formed integrally with the shaft 420, or can be etched from a shaft using a laser or other means well known in the art. The bristles and shaft may be formed of a strong, non-reactive, and medical grade material such as surgical steel. In one embodiment, the bristles 425 extend along the longitudinal axis of the shaft 425, but radiate slightly outward from the shaft axis. In this manner, the bristles 425 can be collected or "bunched" to pass through the shaft 348, but can expand or "fan" upon exiting of the shaft 348. If desired, the bristles can be straight or curved, to facilitate passage through the cancellous bone 115. In addition, if desired, one or more of the bristles 425 may be hollow, allowing a practitioner to take a biopsy sample of the cancellous bone during insertion of the device 410.

[0099] As shown in FIG. 7, the cavity-forming device 410 can desirably be inserted through a shaft 348 positioned in a targeted bone, such as a vertebral body 105. As the bristles 425 enter the cancellous bone 115, the bristles 425 will desirably displace the bone 115 and create one or more cavities 426 or preferred flowpaths in the vertebral body. If desired, a practitioner can withdraw the bristles 425 back into the shaft 348, reposition the cavity-forming device 410 (such as by rotating the device 410), and reinsert the bristles 425, thereby creating additional cavities in the cancellous bone 115. After removal of the cavity-forming device 410, a material, such as a bone filler (not shown), may be introduced through the shaft 348. The bone filler will desirably initially travel through the cavities 426 created by the bristles 425. If desired, a practitioner may interrupt introduction of the bone filler and create additional cavities by reinserting the cavity-forming device 410. In addition, in the event bone filler leakage occurs or is imminent, a practitioner can interrupt bone filler injection, create additional cavity(ies) as described above, wait for the introduced/leaking bone filler to harden sufficiently to resist further extravasation, and then continue introduction of bone filler. As previously described, the bone filler could comprise many different materials, or combinations of materials, with varying results.

[0100] FIG. 14 depicts a cavity-forming device 500 constructed in accordance with an alternate embodiment of the present invention. The cavity-forming device 500 comprises a shaft 520 which is sized to pass through the shaft 348 of an insertion device 350. A handle assembly 515, which facilitates manipulation of the cavity-forming device 500, is secured to the proximal end 512 of the shaft 520. The shaft 520 of the cavity-forming device 500 is desirably longer than the shaft 348 of the insertion device 350. The distal end 525 of the shaft 520 can be beveled (not shown) to facilitate passage through cancellous bone 115, or can be rounded or flattened to minimize opportunities for penetrating the anterior wall 10 of the vertebral body 105. In addition, if desired, the distal 525 end of the shaft 520 could be hollow (not shown), allowing the practitioner to take a biopsy sample of the cancellous bone 115 during insertion of the device 500.

[0101] FIG. 15 depicts a cavity-forming device 600 constructed in accordance with an alternate embodiment of the present invention. Cavity-forming device 600 comprises a shaft 620 which is sized to pass through the shaft 348 of an insertion device 350. A handle assembly 615, which facilitates manipulation of the cavity-forming device 600, is secured to the proximal end 612 of the shaft 620. The shaft 620 is desirably longer than the shaft 348 of insertion device 350. The distal end 625 of the shaft 620 can be beveled (not shown) to facilitate passage through cancellous bone 115, or can be rounded or flattened to minimize opportunities for penetrating the anterior wall 10 of the vertebral body 105. In this embodiment, the distal end 625 of the device 600 incorporates drill threads 627 which can facilitate advancement of the device 600 through cancellous bone 115. In addition, if desired, the distal 625 end of the shaft 620 could be hollow, allowing the practitioner to take a biopsy sample of the cancellous bone 115 during insertion of the device 600.

[0102] After removal of the device(s), bone filler (not shown) may be introduced through the shaft 348. Desirably, the bone filler will initially travel through the cavity(ies) created by the device(s). If desired, a practitioner can interrupt introduction of bone filler and create additional cavity(ies) by reinserting the device(s). In addition, in the event bone filler leakage occurs or is imminent, the practitioner can interrupt bone filler introduction, create additional cavity(ies) as described above, wait for the introduced/leaking bone filler to harden sufficiently, and then continue introducing bone filler. As previously described, the bone filler could comprise many different materials, or combinations of materials, with varying results.

[0103] FIGS. 18-20 depicts a cavity-forming device 600a constructed in accordance with another alternate embodiment of the present invention. Because many of the components of this device are similar to those previously described, similar reference numerals will be used to denote similar components. Cavity-forming device 600a comprises a shaft 620a which is sized to pass through the shaft 348 of an insertion device 350. A handle assembly 615a, which facilitates manipulation of the cavity-forming device 600a, is secured to the proximal end 612a of the shaft 620a. The shaft 620a is desirably longer than the shaft 348 of insertion device 350. The distal end 625a of the shaft 620a can be rounded or beveled to facilitate passage through cancellous bone 115, or can be or flattened to minimize opportunities for penetrating the anterior wall 10 of the vertebral body 105.

[0104] An opening or window 700 is desirably formed in the shaft 620a. As shown in FIGS. 19 and 20, an expandable structure 710 is located at least partially within the shaft 620a, desirably at a position adjacent the window 700. Upon introduction of inflation fluid through a lumen extending through the shaft 620a, the expandable structure 710 expands and at least a portion of the expandable structure 710 will extend out of the shaft 620a through the window 700. Desirably, as the structure continues to expand, the expandable structure 710 will "grow" (P1 to P2 to P3 in FIG. 20) through the window 700, thereby compacting cancellous bone, creating a cavity and/or displacing cortical bone. Upon contraction of the expandable structure 710, most of the expandable structure 710 will desirably be drawn back into the shaft 620a for removal of the tool from the vertebral body. In one embodiment, at least a portion of the material comprising the expandable structure 710 will plastically deform as it expands.

[0105] The expandable structure 710 may be comprised of a flexible material common in medical device applications, including, but not limited to, plastics, polyethylene, mylar, rubber, nylon, polyurethane, metals or composite materials. Desirably, the shaft 620a will comprise a material that is more resistant to expansion than the material of the expandable structure 710, including, but not limited to, stainless steel, ceramics, composite material and/or rigid plastics. In an alternate embodiment, similar materials for the expandable structure 710 and shaft 620a may be used, but in different thickness and/or amounts, thereby inducing the expandable structure to be more prone to expansion than the shaft 620a material. The expandable structure 710 may be bonded directly to the shaft 620a by various means well known in the art, including, but not limited to, means such as welding, melting, gluing or the like. In alternative embodiments, the expandable structure may be secured inside or outside of the shaft 620a, or a combination thereof.

[0106] As previously noted, any of the cavity-forming devices 500, 600 and 600a may be inserted through a shaft 348 positioned in a targeted bone, such as a vertebral body 105. As the device(s) enter the cancellous bone 115, they will desirably displace the bone 115 and create one or more cavities in the vertebral body. If desired, the physician can withdraw the device(s) back into the shaft 348 and reinsert as necessary to create the desired cavity(ies) in the cancellous bone 115.

[0107] In the embodiment of a cavity-forming device of FIGS. 18-20, the cavity-forming device 600a may be utilized without an associated insertion device. In such a case, the cavity-forming device desirably will incorporate a sharpened distal tip capable of penetrating the soft tissues and cortical/cancellous bone of the vertebral body. If desired, the distal tip can be hollow or a solid construct. Similarly, the window may extend around more or less of the periphery of the shaft 620a, depending upon the size and configuration of the expandable structure and the desired strength of the cavity-forming device.

[0108] By creating one or more cavities within the cancellous bone 115, the cavity-forming devices of the present invention desirably create preferred flowpaths for the bone filler 180. In addition, the cavity-forming devices can also desirably close and/or block other natural flowpaths out of the cavity, such as veins and/or cracks in the cancellous bone. Moreover, methods and devices disclosed herein can be used

to manipulate bone filler already introduced into the bone. Thus, the present invention reduces opportunities for cement leakage outside of the vertebral body and/or improves the distribution of bone filler throughout significant portions of the vertebral body. In addition, the creation of cavities and desired flowpaths described in the present invention permits the placement of biomaterial more safely, under greater control and under lower pressures.

[0109] In addition to the specific uses described above, the cavity-forming devices and methods described herein would also be well-suited for use in treating and/or reinforcing weakened, diseased and/or fractured bones and other organs in various locations throughout the body. For example, the disclosed devices and methods could be used to deliver reinforcing materials and/or medications, such as cancer drugs, replacement bone cells, collagen, bone matrix, demineralized calcium, and other materials/medications, directly to a fractured, weakened and/or diseased bone, thereby increasing the efficacy of the materials, reinforcing the weakened bone and/or speed healing. Moreover, injection of such materials into one bone within a body could permit the medication/material to migrate and/or be transported to other bones and/or organs in the body, thereby improving the quality of bones and/or other organs not directly injected with the materials and/or medications.

[0110] Other embodiments and uses of the invention will be apparent to those skilled in the art from consideration of the specification and practice of the invention disclosed herein. All documents referenced herein are specifically and entirely incorporated by reference. The specification and examples should be considered exemplary only with the true scope and spirit of the invention indicated by the following claims. As will be easily understood by those of ordinary skill in the art, variations and modifications of each of the disclosed embodiments can be easily made within the scope of this invention as defined by the following claims.

We claim:

1. A method for treating bone after high velocity and/or trauma fracture comprising the steps of:

inserting an insertion device percutaneously into a vertebral body;

inserting a cavity-forming device through the insertion device into an area of cancellous bone in the vertebral body;

displacing cancellous bone with the cavity-forming device to create a cavity and a barrier region of compressed cancellous bone substantially surrounding the cavity; and

filling at least a portion of the cavity with a bone filler.

2. The method of claim 1 further wherein, after the filling step, inserting a cavity-forming device into the cavity and compressing at least a portion of the bone filler against the barrier region.

3. The method of claim 1 wherein the needle assembly comprises a needle.

4. The method of claim 3 wherein the needle assembly comprises an eleven-gauge needle.

5. The method of claim 1 wherein the cavitation device is selected from the group consisting of a mechanical tamp, a reamer, a drill, a hole puncher and a balloon catheter.

6. The method of claim 1 wherein the cavitation device is a balloon catheter comprising:

a tube comprising a distal end and a proximal end;

an expandable structure; and

a fitting comprising at least one port;

7. The method of claim 6 wherein the tube of the balloon catheter is hollow and comprises at least one opening near the distal end of the tube.

8. The method of claim 7 wherein the expandable structure of the catheter is bonded to the distal end of the tube.

9. The method of claim 8 wherein the expandable structure is inflated with an inflation medium, thereby forming a cavity and a barrier surrounding the cavity within the vertebral body; and wherein the expandable structure is subsequently deflated and removed through the insertion device.

10. The method of claim 9 wherein the inflation medium is selected from the group consisting of air, nitrogen, saline, water and combinations thereof.

11. The method of claim 1 wherein the bone filler includes calcium phosphate.

12. A method for treating bone after high velocity and/or trauma fracture comprising the steps of:

inserting a spinal needle of a needle assembly percutaneously through a pedicle into a vertebral body;

inserting a balloon catheter through the spinal needle into an area of cancellous bone within the vertebral body, so that the distal end of the balloon catheter extends out of the distal end of the spinal needle;

inflating the balloon catheter with an inflation medium such that inflation of the distal end of the balloon catheter extending from the spinal needle displaces cancellous bone around the inflating balloon, forming a barrier around the balloon catheter that at least partly closes large cracks or veins within the cancellous bone area of the vertebral body;

deflating the balloon catheter and leaving a cavity within the cancellous bone area of the vertebral body;

removing the balloon catheter from the vertebral body through the needle assembly; and

filling the cavity with a bone filler.

13. The method of claim 12 wherein the inflation medium comprises sterile saline.

14. The method of claim 13 wherein the bone filler includes calcium phosphate.

15. A system for treating bone after high velocity and/or trauma fracture comprising

an insertion device sized and configured to be inserted percutaneously into a vertebral body;

a cavity-forming device sized and configured to be inserted through the insertion device into an area of cancellous bone in the vertebral body to displace cancellous bone and create a cavity; and

a bone filler including calcium phosphate for filling at least a portion of the cavity.

* * * * *