



INTERNATIONAL APPLICATION PUBLISHED UNDER THE PATENT COOPERATION TREATY (PCT)

<p>(51) International Patent Classification ⁶ : G07C 9/02</p>	<p>A1</p>	<p>(11) International Publication Number: WO 96/34367</p> <p>(43) International Publication Date: 31 October 1996 (31.10.96)</p>
<p>(21) International Application Number: PCT/GB96/00963</p> <p>(22) International Filing Date: 23 April 1996 (23.04.96)</p> <p>(30) Priority Data: 9508512.2 26 April 1995 (26.04.95) GB</p> <p>(71) Applicant (for all designated States except US): THORN TRANSIT SYSTEMS INTERNATIONAL LIMITED [GB/GB]; Penleigh Works, Wookey Hole Road, Wells, Somerset BA5 1AA (GB).</p> <p>(72) Inventors; and (75) Inventors/Applicants (for US only): TAYLOR, Robert [GB/GB]; The Manor House, Manor House Farm, Keinton Mandeville, Somerset TA11 6EG (GB). WEBB, Roger, Clive [GB/GB]; 4 St. Cuthberts Way, Wells, Somerset BA5 2JL (GB). DYKES, Norman, Alan [GB/GB]; Stock Elm Cottage, Compton Dunston, Somerton, Somerset TA11 6PU (GB). JONES, Roger [GB/GB]; 1 Gunwyn Close, Glastonbury, Somerset BA6 8HB (GB).</p> <p>(74) Agent: MARSH, Robin, Geoffrey; Thorn Emi Patents Limited, Central Research Laboratories, Dawley Road, Hayes, Middlesex UB3 1HH (GB).</p>		<p>(81) Designated States: CA, CN, GB, KR, US, European patent (AT, BE, CH, DE, DK, ES, FI, FR, GB, GR, IE, IT, LU, MC, NL, PT, SE).</p> <p>Published <i>With international search report. Before the expiration of the time limit for amending the claims and to be republished in the event of the receipt of amendments.</i></p>

(54) Title: APPARATUS FOR CONTROLLING ACCESS

(57) Abstract

Apparatus for controlling access comprises (a) a passage provided with a barrier having an open position and a closed position, (b) means for reading fare data, (c) means for monitoring the position of a plurality of passengers in the passage and to provide corresponding signals, and (d) means for controlling the barrier in response to the fare data and the signals, and for associating the fare data with a given signal. The barrier includes a magnetic latch which can improve reliability.

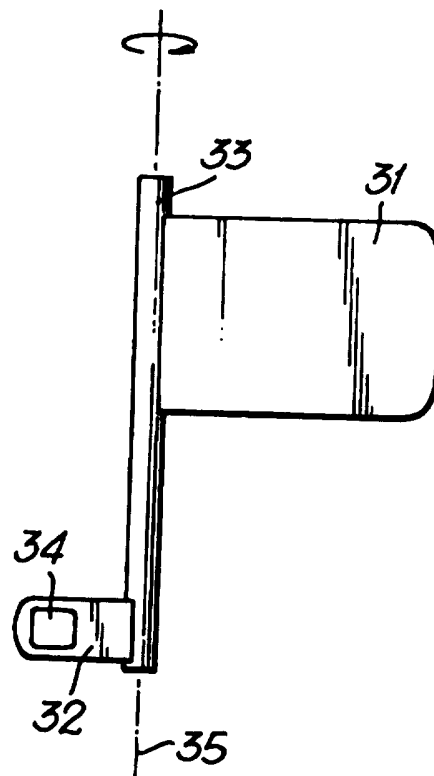

FOR THE PURPOSES OF INFORMATION ONLY

Codes used to identify States party to the PCT on the front pages of pamphlets publishing international applications under the PCT.

AM	Armenia	GB	United Kingdom	MW	Malawi
AT	Austria	GE	Georgia	MX	Mexico
AU	Australia	GN	Guinea	NE	Niger
BB	Barbados	GR	Greece	NL	Netherlands
BE	Belgium	HU	Hungary	NO	Norway
BF	Burkina Faso	IE	Ireland	NZ	New Zealand
BG	Bulgaria	IT	Italy	PL	Poland
BJ	Benin	JP	Japan	PT	Portugal
BR	Brazil	KE	Kenya	RO	Romania
BY	Belarus	KG	Kyrgystan	RU	Russian Federation
CA	Canada	KP	Democratic People's Republic of Korea	SD	Sudan
CF	Central African Republic	KR	Republic of Korea	SE	Sweden
CG	Congo	KZ	Kazakhstan	SG	Singapore
CH	Switzerland	LI	Liechtenstein	SI	Slovenia
CI	Côte d'Ivoire	LK	Sri Lanka	SK	Slovakia
CM	Cameroon	LR	Liberia	SN	Senegal
CN	China	LT	Lithuania	SZ	Swaziland
CS	Czechoslovakia	LU	Luxembourg	TD	Chad
CZ	Czech Republic	LV	Latvia	TG	Togo
DE	Germany	MC	Monaco	TJ	Tajikistan
DK	Denmark	MD	Republic of Moldova	TT	Trinidad and Tobago
EE	Estonia	MG	Madagascar	UA	Ukraine
ES	Spain	ML	Mali	UG	Uganda
FI	Finland	MN	Mongolia	US	United States of America
FR	France	MR	Mauritania	UZ	Uzbekistan
GA	Gabon			VN	Viet Nam

APPARATUS FOR CONTROLLING ACCESS

This invention relates to apparatus for controlling access. It relates particularly, though not exclusively, to a barrier for use in such apparatus.

In a known apparatus of this type called the TAG-150 Automatic Gate (available from Takamisawa K.K. in Japan), sensing means comprising a plurality of horizontally spaced photoelectric sensors is provided to sense the presence of a person in a passage. A ticket reading means is placed adjacent the entrance to the passage. If a person approaches the barrier without having first presented a valid ticket to the reading means, the barrier is controlled to be in a closed condition which prevents access. Further sensors are provided to ensure that the barrier does not close if there is an obstruction at the barrier position, thereby increasing passenger safety. In general, such systems may operate in a normally open state (in which the passage is open until the barrier is placed into its closed condition when an invalid fare and a subject are sensed), or a normally closed state (in which the barrier is only placed into its open condition when a valid fare and a subject are sensed).

A disadvantage with such systems is, however, that the throughput of people in such automatic gates is low. People tend to wait at the ticket reading station until the barrier has responded. This causes a queue at busy times or requires the owner of the access system to purchase many more gates than would be necessary if the throughput could be increased. If a second person without a valid ticket attempts to enter the passage whilst a first person is still in the passage the barrier can be activated, thus trapping the first person even although they are in possession of a valid ticket. If a second person with a valid ticket attempts to enter the passage whilst a first person is in the passage, they often find that the ticket reading machine will not accept their ticket immediately because the previous person's ticket is still present in the reading system or has not been removed from the outlet port of the ticket reading system. These disadvantages tend to reduce throughput of the access system resulting in queues with concomitant safety and ticket security problems.

Improved apparatus to overcome these problems has been disclosed in GB 1,207,263, GB 1,245,189 and GB 1,263,542. The barriers described in these documents use electric motors and conventional mechanical latches to keep the barriers in a closed condition to prevent access. Such a solution includes many moving parts which suffer from friction and consequently wear and require periodic maintenance.

According to the invention there is provided a barrier for use in apparatus for controlling access, the barrier comprising a first member and a second member, the members being coupled to one another, the first member being adapted for inhibiting access to a passage, the second member having a surface comprising a ferromagnetic material for

cooperating with control means including an electromagnet for holding the barrier in an open or closed condition. Preferably the members are both coupled to a pivotable shaft.

The barrier conveniently comprises one or more members which extend into the passage to a greater extent when the barrier is in the closed condition than when the barrier is in the open condition. The one or more members are advantageously pivotable about an axis in a plane substantially parallel to the direction of access.

The apparatus conveniently comprises a means for reading fare or toll data at both ends of the passage such that access in either direction along the passage may be controlled. Preferably the apparatus further comprises means to change the allowed direction of access from one way to the opposite way. In this example the apparatus advantageously comprises a pair of barriers spaced apart along the passage and each being arranged adjacent an end of the passage.

Embodiments of the invention will now be described, by way of example only, with reference to the accompanying diagrammatic drawings in which :-

Figure 1 shows a side elevation of apparatus according to one embodiment of the invention,

Figure 2 shows a plan view of a plurality of passages arranged side by side, each having a side as shown in Figure 1,

Figure 3 shows a barrier according to one embodiment of the invention,

Figure 4 shows a flow diagram of a method of controlling access.

Figure 2 shows a plan view of one example of apparatus according to the invention. The apparatus for controlling access comprises a passage (1) having a barrier (2, 3) controllable into an open condition and a closed condition, and means (4) for reading fare or toll data. The passage is formed between two side assemblies (5, 6).

The side assemblies are as shown in side elevation in Figure 1. Each side assembly includes sensing means (11 - 26) for sensing the position of a plurality of subjects in the passage and providing corresponding signals. In the present example the sensing means comprises twenty sensor pairs, each pair comprising a transmitter (for example a light source) on one side of the passage and a receiver (for example a photoelectric cell detector for detecting light emitted by the light source) on the other side of the passage. Only one member of each pair is shown in Figure 1. The sensing means operates by sensing a break in a beam of energy travelling between the transmitter and the receiver caused by a subject in the passage. In the present example the beam of energy is a beam of light, however other beams such as infra-red beams or ultrasonic beams may be used as an alternative.

The apparatus further comprises means (in the present example a microcomputer system having a memory) for associating given data with a signal corresponding to a given subject, and means for controlling the barrier (in the present example an electric motor and electromagnet together with a micro-controller), such that in operation when the given data

associated with the signal corresponding to the given subject is invalid or absent, the barrier is controlled to be in the closed condition when the given subject approaches the barrier, thereby denying access to the given subject whilst allowing access to any other subject having a signal associated with valid data being in the passage between the given passenger and the barrier.

Each sensor pair is positioned such that the beam of energy travels directly across the passage (in a direction approximately perpendicular to the direction of motion of the subjects) from the transmitter to the corresponding receiver. For the present we will only consider subjects entering the passage from one direction, and we shall call one end of the passage (27) the entrance, and the other end of the passage (28) the exit. The software operating the apparatus is arranged such that a new subject is only recognized at the entrance to the passage. Sensors pairs 11 and 13 (called the detection group) must both show an interrupted beam to denote a tall human subject. Signals from this sensor pair are immediately attributed to a new subject, and the information is stored in a memory location specific to the new subject. Signals arising from sensors not at the entrance to the passage do not result in a new subject being recognized.

Once a new subject is recognized and a memory location associated with the new subject set aside, further signals caused by interrupted beams are attributed to that passenger if the signal is from a sensor pair adjacent the sensor pair already detecting the subject. There is no limit on the number of sensor pair signals that can be attributed to any one subject. This feature enables subjects carrying large pieces of luggage to be correctly sensed and monitored as they progress through the passage. If a signal cannot be attributed to an existing passenger, then the possibility of a new passenger is considered. A new subject is recognized if the detection group beams are interrupted and none of them can be attributed to an existing subject. For this condition to be true, sensor pair 14 must be cleared by all existing subjects in the passage before sensor pair 13 is interrupted by a new subject. This is because if an existing subject was attributed with interrupting sensor pair 14 whilst a new subject interrupts sensor pair 13, the signals would all be attributed to the existing subject on the basis that the sensor pair 14 is adjacent sensor pair 13. Thus the criterion for recognizing a new subject is an interruption in sensor pair 11 and 13 but not 14.

Short human subjects are sensed in the same way as described above for tall subjects, but in this case the relevant sensor pairs in the detection group are 11, 12 and (not) 14. Note that if a short subject jumps over sensor pair 12, it is likely that sensor pair 13 will be interrupted instead so that the short subject will be recognized as a tall subject. If a short subject is recognized, then sensor pair 13 will be ignored and sensor pairs 11 and 14 will be deemed to be adjacent pairs.

Once a new subject is recognized, its position in the passage is monitored as it interrupts sensor pairs and clears sensor pairs. Forward and/or backward motion will be

detected. Signals that cannot be reasonably attributed to an existing subject are ignored. This feature can be helpful if there are subjects in the passage who, for example, wave umbrellas or other items about as they move through the passage. Such a system of monitoring subjects in the passage also makes the segregation of various sensor pairs into different sensing "zones" as is performed in some systems unnecessary.

The sensor pairs need not necessarily comprise a transmitter on one side and a receiver on the other side of the passage. The transmitter and receiver may be located next to one another on the same side of the passage together with a surface which reflects the radiation beam on the other side of the passage so that the beam is transmitted from the transmitter across the passage, then reflected from the reflective surface back across the passage to be received by the receiver.

To ensure passenger safety, the following measures are taken:-

- a) A given barrier is never moved if any sensors in the sensor group 12 and 26 or sensor group 23 and 25 associated with the given barrier are being interrupted. In the present example the sensor groups 25 and 26 each comprise three sensor pairs whose outputs are commoned together.
- b) If an object is seen to interrupt sensor groups 23 and 25 together or 12 and 26 together without interrupting any other sensors it is assumed that there is a small child in the aisle. In this case no attempt will be made to close any set of doors until one tall subject has been tracked right along the passage or to the exit barrier if this is closed.
- c) If a valid subject apparently disappears in the middle of the passage (for example if he kneels down, or if a bag was falsely detected as a passenger) the apparatus is re-credited so that the barriers will not close in close proximity to him in normally closed mode, or if an invalid subject enters the passage behind him. (This measure also ensures that such a passenger will not lose the payment and be prevented from passing).

In operation, when a new passenger is detected a check is made to see if a valid ticket or card has been presented. If so the passenger shall be allowed to pass unhindered. Otherwise, alarms are activated and the barrier or barriers at the other end of the passage are closed as soon as possible when this will not compromise safety or prevent valid passengers already in the passage from passing. In the present example the alarms cease and the doors are opened again (if being operated in normally open mode) when the invalid subject leaves the passage. If the invalid subject disappears in the middle of the passage the barrier will remain closed until a valid ticket is presented or a time period has elapsed. In normally closed mode, the barriers are closed again when there are no ticket credits left and all valid subjects have passed through the passage. They are also closed in normally open mode when there is an invalid subject in the passage and all valid subjects have left the passage.

When a passenger is in a position to retrieve his ticket it is important to make it difficult for him to take the ticket of any passenger following him. In the present example this is achieved in the following way. When a ticket is captured by the apparatus or retrieved by a subject, the next ticket will not be returned until the following conditions are satisfied:-

- a) All other valid passengers have moved passed a collection zone (for example, passed sensor pairs 11-16 in the present example)
- b) The new passenger owning the ticket to be returned has entered the passage or,
- c) A time period has elapsed (regardless of passenger positions).

The system usually operates in what is known as a "normally open" mode in which the barrier is in its open condition unless a subject associated with absent or invalid data approaches the barrier. The apparatus may also be used in a "normally closed" mode in which the barrier remains in its closed condition unless a subject associated with valid data approaches the barrier. When operating in either mode the access system can be set to either allow subjects from only one direction to obtain access or to allow access to subjects from either direction depending upon which subject is sensed by the system first. The former mode of operation is sometimes called the "unidirectional" mode whilst the latter mode of operation is sometimes known as the "bi-directional" mode.

Although a barrier which does not obstruct the passage when it is in its open condition has been described in the above description, a turnstile or other barrier which always obstructs the passage to some extent may be used as an alternative (although in this case the advantage of greater throughput will not be so apparent).

The barrier shown in Figure 3 is particularly advantageous for use in the above apparatus. In Figure 3 the barrier comprises a first member (31) and a second member (32), the members being coupled to one another on opposite sides of a pivot (33), the first member (31) is constructed and arranged to inhibit access to a passage, the second member (32) having a surface (34) comprising a ferromagnetic material for cooperating with control means including an electromagnet (not shown) to hold the barrier in an open or closed condition. In the example shown in this figure the members are both coupled to a pivotable shaft (33) which rotates about an axis of rotation (35). In this example the axis of rotation is coaxial with the shaft, but other axes of rotation may be used as an alternative. For example the shaft may be pivotable in the plane of the axis of the shaft with an axis of rotation normal to the axis of the shaft and the two members being coupled to either end of the shaft.

The first member (31) is padded so that if a passenger runs into the barrier when it is in a closed condition the passenger is not badly injured. The size of the ferromagnetic surface and the strength of the electromagnet is arranged such that a force of approximately 1100 Newton must be used to open the barrier when it is in its closed condition. The choice of this

"release" force depends upon a number of factors. Firstly, if there is an emergency and a crowd of people are pushed against the barrier the release force must be set sufficiently low to prevent injury to passengers by crushing. However, the release force must not be too low or a strong passenger wanting to avoid paying a fare or toll could just push their way through the barrier. With the present barrier it is easy to set and change this force simply by changing the electric current flowing to the electromagnet. Release forces in the range 700 - 2000 Newton may typically be employed. The force may be partly mechanical in addition to electromagnetic, for example by employing rolling element bearings which have to be forced out of locating cups into which they are biased (by for example a strong spring), or other mechanical systems commonly used in such barrier systems.

The main advantage of the present barrier over the prior art devices which use an electric motor arrangement is that there is a minimum of moving parts resulting in much lower wear and lower maintenance and replacement part costs. The barrier of the present invention includes a magnetic latch. In the present examples, the barrier moves towards the subject when it closes, although other directions of movement may be employed if desired. To improve safety it is advisable to have a mechanical break set at a similar force as that of the electromagnetic break so that if there is a crush of people wanting to enter the passage in the opposite way to that for which it is set up the barrier will move before injury occurs. It is also wise to have a battery backup for such systems so that the barrier may be controlled to be in an open condition if there is a power failure in addition to an emergency.

Figure 4 shows a flow diagram of a method of controlling access by a subject from a first region to a second region via a passage having a barrier. In this flow diagram of one example of a method according to the invention the numbered blocks correspond to steps in the method. The blocks have the following significances. Block 40 denotes reading fare or toll data from a given subject. Block 41 denotes deciding if the data is valid or invalid. The next block (42) denotes storing a credit in a memory if the data is valid. Block 43 denotes sensing the presence and position of the given subject and providing at least one sensing signal as the given subject moves through the passage, thereby providing information on the position of the given subject in the passage with time. Block 44 denotes associating the credit or lack of a credit with the position of the given subject in the passage. Block 45 denotes controlling the barrier to substantially prevent access through the passage by the given subject when a lack of a credit is in association with the position of the given subject whilst allowing access by any other subject being in association with valid data and being in the passage between the given subject and the barrier.

CLAIMS

1. A barrier for use in apparatus for controlling access, the barrier comprising a first member and a second member, the members being coupled to one another, the first member being adapted for inhibiting access to a passage, the second member having a surface comprising a ferromagnetic material for cooperating with control means including an electromagnet for holding the barrier in an open or closed condition.
2. A barrier as claimed in claim 1 in which the members are both coupled to a pivotable shaft.
3. A barrier as claimed in claim 2 in which the shaft is axially rotatable.
4. Apparatus for controlling access comprising a) a passage having a barrier as claimed in any preceding claim controllable into an open condition and a closed condition, b) means for reading fare or toll data, c) sensing means for sensing the position of a plurality of subjects in the passage and providing corresponding signals, d) means for associating given fare or toll data with one or more signals corresponding to a given subject, and e) means for controlling the barrier, such that in use when the given fare or toll data corresponding to the given subject is invalid or absent, the barrier is controlled to be in the closed condition when the given subject approaches the barrier, thereby denying access to the given subject whilst allowing access to any other subject being in the passage between the given passenger and the barrier.
5. Apparatus as claimed in claim 4 in which the means for reading fare or toll data consists of a money collection system, and the data comprises at least one of the group including; a credit card, a smart card, one or more coins and/or banknotes.
6. Apparatus as claimed in claim 4 in which the means for reading fare or toll data consists of a ticket reading system, and the data comprises an encoded ticket or card.
7. Apparatus as claimed in claim 4 constructed and arranged such that the subject retains possession of the ticket or card whilst it is being read and/or written to.
8. Apparatus as claimed in claim 4 in which the barrier comprises one or more members which extend into the passage to a greater extent when the barrier is in the closed condition than when the barrier is in the open condition.
9. Apparatus as claimed in claim 8 in which the one or more members are pivotable about an axis in a plane substantially parallel to the direction of access.
10. Apparatus as claimed in claim 4 - 9 in which the apparatus includes a battery for supplying electrical power in an emergency.

Fig.1.

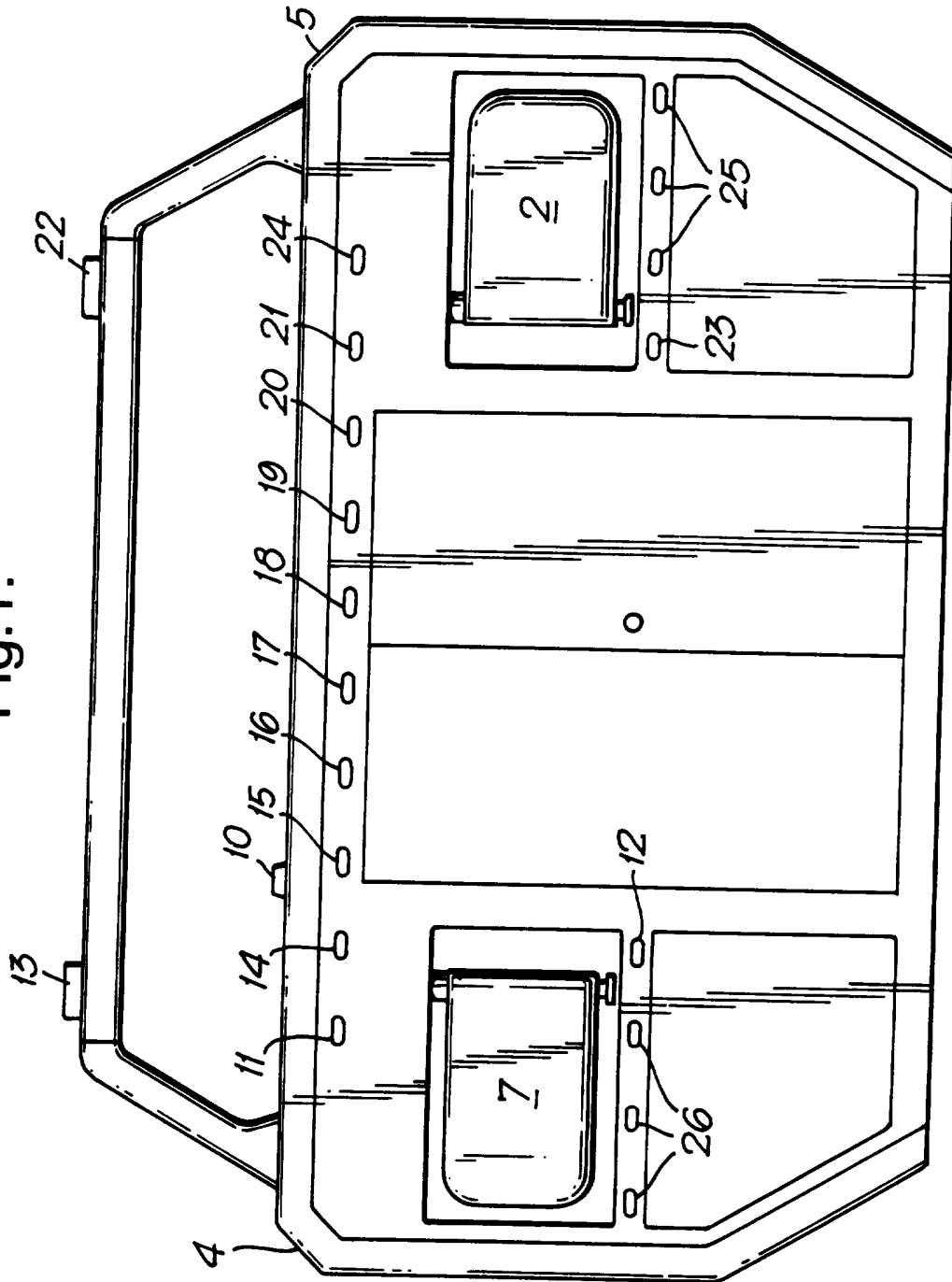

Fig.2.

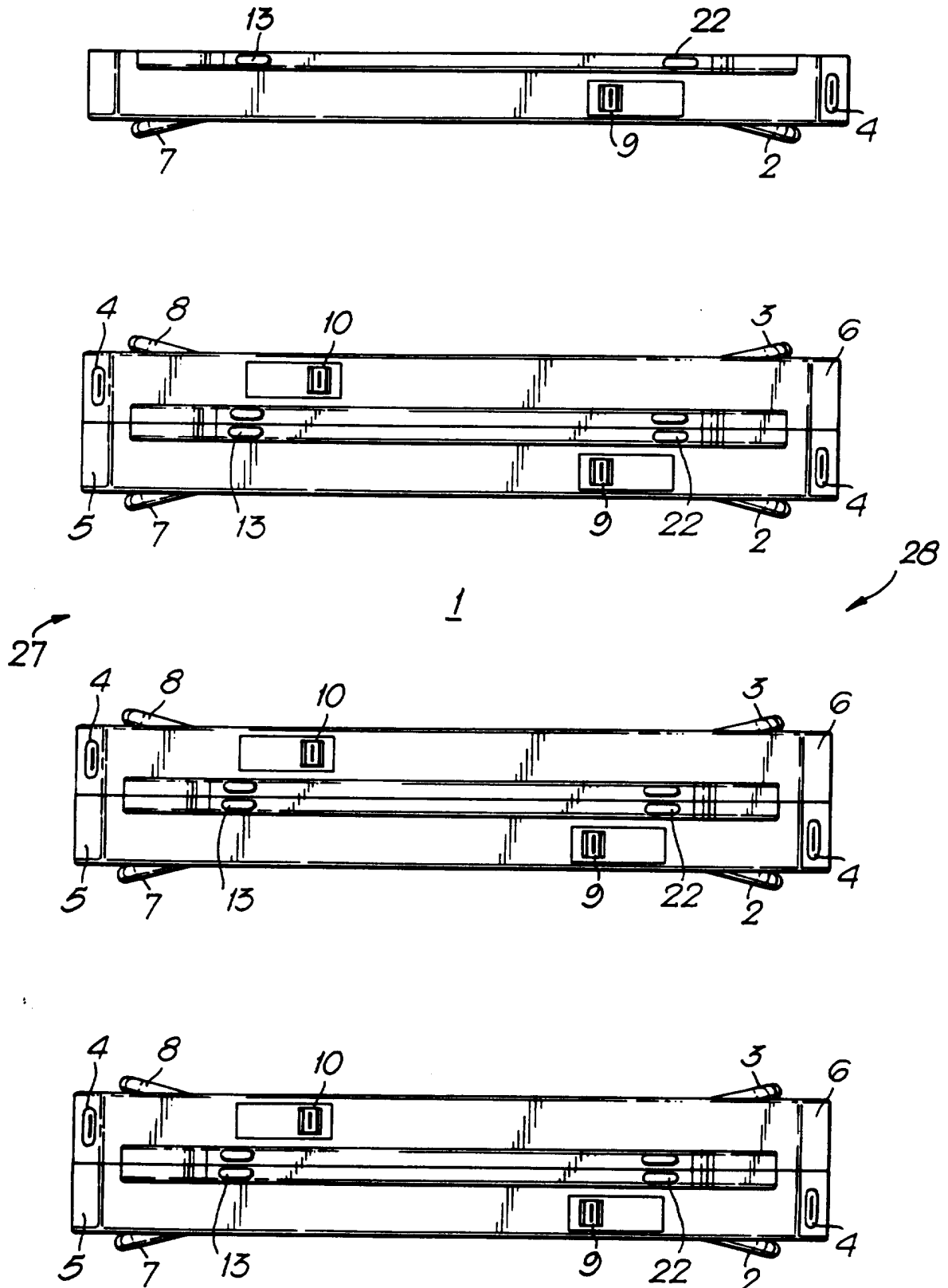

Fig.3.

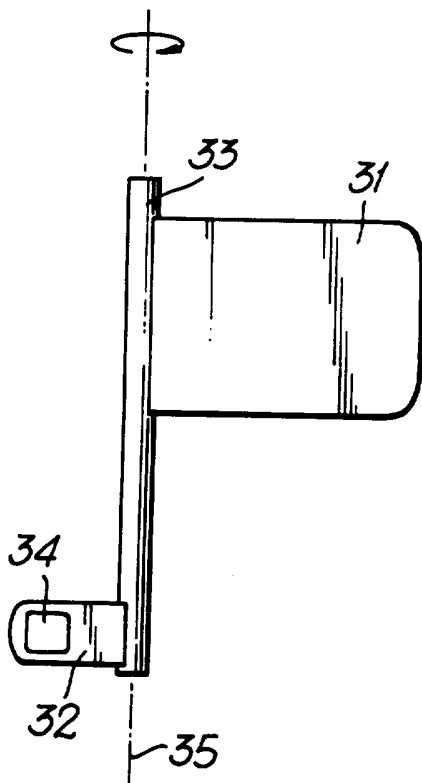
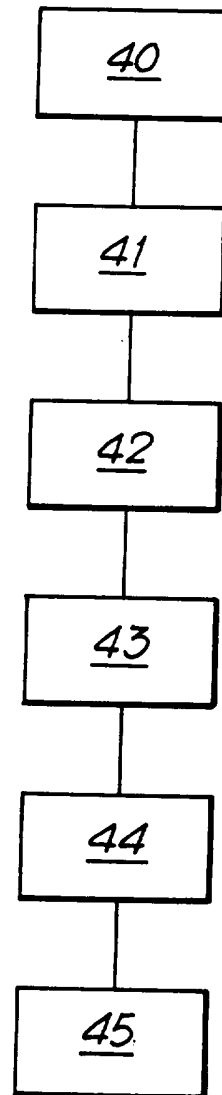

Fig.4.



INTERNATIONAL SEARCH REPORT

International Application No

PCT/GB 96/00963

A. CLASSIFICATION OF SUBJECT MATTER
IPC 6 G07C9/02

According to International Patent Classification (IPC) or to both national classification and IPC

B. FIELDS SEARCHED

Minimum documentation searched (classification system followed by classification symbols)

IPC 6 G07C E05C

Documentation searched other than minimum documentation to the extent that such documents are included in the fields searched

Electronic data base consulted during the international search (name of data base and, where practical, search terms used)

C. DOCUMENTS CONSIDERED TO BE RELEVANT

Category *	Citation of document, with indication, where appropriate, of the relevant passages	Relevant to claim No.
X	EP 0 045 197 A (BSG SECURITY LTD) 3 February 1982	1-3
Y	see claim 1; figure 4A ---	4-10
Y	DE 20 04 165 A (COMPAGNIE DES COMPTEURS) 20 August 1970 see claim 1; figure 1 ---	4-10
A	WO 94 08258 A (OCTROOIBUREAU KISCH N V ;VERMEULEN PIETER JOHANNES ERAS (ZA); PUTT) 14 April 1994 see claim 1; figure 1 ---	4-10
A	DE 93 14 530 U (WANZL ENTWICKLUNG GMBH) 4 November 1993 see claim 1; figure 1 ---	4-10
	-/--	

Further documents are listed in the continuation of box C.

Patent family members are listed in annex.

* Special categories of cited documents :

- *A* document defining the general state of the art which is not considered to be of particular relevance
- *E* earlier document but published on or after the international filing date
- *L* document which may throw doubts on priority claim(s) or which is cited to establish the publication date of another citation or other special reason (as specified)
- *O* document referring to an oral disclosure, use, exhibition or other means
- *P* document published prior to the international filing date but later than the priority date claimed

- *T* later document published after the international filing date or priority date and not in conflict with the application but cited to understand the principle or theory underlying the invention
- *X* document of particular relevance; the claimed invention cannot be considered novel or cannot be considered to involve an inventive step when the document is taken alone
- *Y* document of particular relevance; the claimed invention cannot be considered to involve an inventive step when the document is combined with one or more other such documents, such combination being obvious to a person skilled in the art.
- *&* document member of the same patent family

Date of the actual completion of the international search

13 September 1996

Date of mailing of the international search report

25. 09. 96

Name and mailing address of the ISA

European Patent Office, P.B. 5818 Patentlaan 2
NL - 2280 HV Rijswijk
Tel. (+ 31-70) 340-2040, Tx. 31 651 epo nl,
Fax (+ 31-70) 340-3016

Authorized officer

Kirsten, K

INTERNATIONAL SEARCH REPORT

Intern: u Application No
PCT/GB 96/00963

C.(Continuation) DOCUMENTS CONSIDERED TO BE RELEVANT		
Category *	Citation of document, with indication, where appropriate, of the relevant passages	Relevant to claim No.
A	DE 23 26 386 A (SCHROEDER HELMUTH M) 24 January 1974 see claim 1; figure 1 -----	1-3
A	GB 1 263 542 A (OMRON TATEISI ELECTRONICS COMPANY) 9 February 1972 cited in the application see claim 1; figure 1 -----	4-10

INTERNATIONAL SEARCH REPORT

Information on patent family members

International Application No

PCT/GB 96/00963

Patent document cited in search report	Publication date	Patent family member(s)	Publication date
EP-A-0045197	03-02-82	US-A- 4439808	27-03-84
		GB-A- 2085956	06-05-82
DE-A-2004165	20-08-70	FR-A- 2029911	23-10-70
		BE-A- 742601	03-06-70
		SE-B- 382706	09-02-76
WO-A-9408258	14-04-94	AU-A- 5150193	26-04-94
		EP-A- 0664012	26-07-95
		US-A- 5519784	21-05-96
		ZA-A- 9307447	25-03-94
DE-U-9314530	04-11-93	EP-A- 0643189	15-03-95
DE-A-2326386	24-01-74	US-A- 3791687	12-02-74
GB-A-1263542	09-02-72	DE-A- 1929922	18-12-69
		FR-A- 2010906	20-02-70
		US-A- 3606698	11-05-71