



(86) 1994/04/28

(87) 1994/11/24

(45) 2001/05/22

(72) Rohlfig, Gerhard, DE

(73) Joh. Heinrich Bornemann GmbH & Co. KG, DE

(51) Int.Cl.⁶ F04C 2/16, F04C 13/00

(30) 1993/05/19 (P 43 16 735.7) DE

(54) **PROCEDE D'EXPLOITATION D'UNE POMPE A VIS
MULTI-PHASEE ET POMPE**

(54) **PUMPING PROCESS FOR OPERATING A MULTI-PHASE
SCREW PUMP AND PUMP**

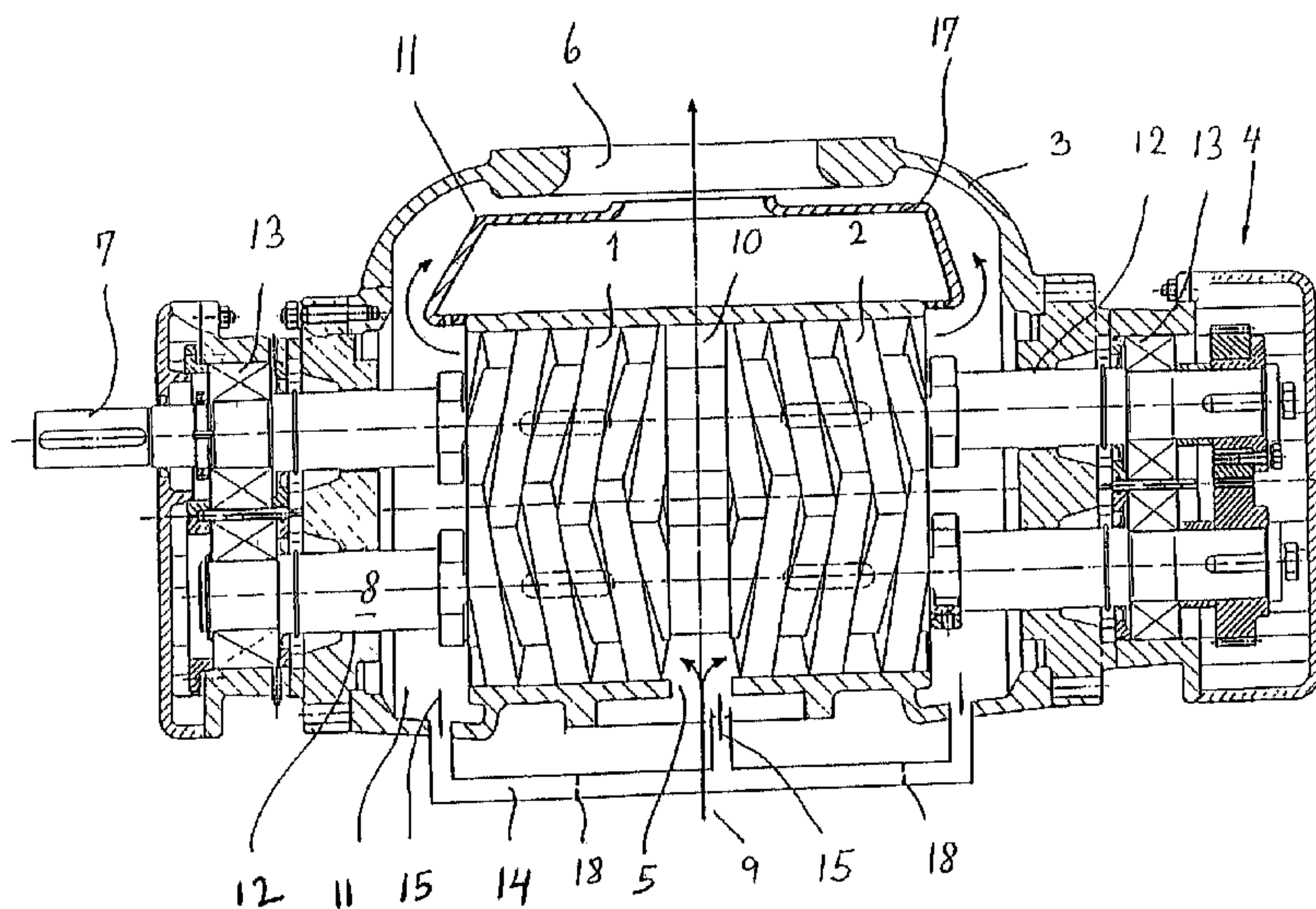

(57) The invention relates to a pumping process for operating a multi-phase screw pump with at least one feed screw surrounded by a housing having at least one intake stub on one side and at least one discharge stub at its top, in which the intake medium is conveyed parallel to the screw shaft in a continuous low-pulsed stream and continuously discharged at the discharge stub. The invention also relates to a multi-phase screw pump. In order to prevent the drawbacks usually occurring in dry running phases, the invention proposes that a partial liquid volume flow (liquid circulation) be separated on the pressure side and returned in metered quantities into the intake region and thus kept in circulation.

2153385

Abstract:

The invention relates to a pumping process for operating a multi-phase screw pump with at least one feed screw surrounded by a housing having at least one intake stub on one side and
5 at least one discharge stub at its top, in which the intake medium is conveyed parallel to the screw shaft in a continuous low-pulsed stream and continuously discharged at the discharge stub. The invention also relates to a multi-phase screw pump. In order to prevent the drawbacks usually occurring in dry
10 running phases, the invention proposes that a partial liquid volume flow (liquid circulation) be separated on the pressure side and returned in metered quantities into the intake region and thus kept in circulation.

Pumping Process for Operating a Multi-Phase Screw Pump
and Pump

5 The invention relates to a pumping process for operating a
multi-phase screw pump with at least one feed screw surrounded
by a housing, having at least one intake stub and at least one
discharge stub, with the intake medium being conveyed parallel
to the screw shaft in a continuous low-pulsed stream and
continuously discharged at the discharge stub, with the
10 respective liquid phase being separated from the gas phase on
the pressure side, while the medium flow emerging from the
feedscrew has its flowrate reduced and/or deliberately steered
in its flow direction.

15 The invention also relates to a multi-phase screw pump with at
least one feed screw, surrounded by a housing, which has at
least one intake stub and at least one discharge stub, with
the intake stub communicating with a suction chamber located
upstream from the feed screw and the discharge stub being
connected with a pressure chamber located downstream from the
20 feed screw, especially to work a process according to one of
the foregoing claims, with the pressure chamber having means
for separating the respective liquid phase from the gas phase
of the medium flow emerging from the feed screw as well as a
lower section to receive at least a partial volume of the
separated liquid phase.

25 The term "multi-phase" refers to a mixture of gas and liquid.
In multi-phase transport, especially with high gas rates or
dry running, the liquid is usually completely expelled. The
feed elements then turn without a liquid to seal the gaps; the
pump can no longer deliver the maximum pressure, which results
30 in an interruption of feed. The heat of compression resulting
from the compression of the gas phase can no longer be removed
sufficiently. This results in overheating of the feed
elements and their expansion with heat, which can result in

destruction of the pump through contact with the housing.

In addition, with high gas rates or dry running, insufficient lubrication develops at the shaft seals, which can result in overheating at the shaft seals and hence to their destruction.

5 When the residual liquid level on the inlet side is at the lower edge of the feed screws, the shaft seals are dry; the lubricant formed by the intake medium evaporates; the heat of friction is no longer removed and results in the destruction of the shaft seal. This problem is currently solved by
10 permanent lubrication and cooling using an external seal oil assembly. These assemblies however are cost-intensive and prone to failure and therefore adversely affect the economy of such pumps.

The pumping process described at the outset as well as the
15 multi-phase screw pump can be found in GB 2 227 057 A. This document is likewise concerned with the problems addressed earlier, which can develop when delivering multi-phase multi-material mixtures in screw pumps. In addition, the idea has already been disclosed that liquid is permanently required
20 to seal the gap. To solve these problems, a phase conversion by condensation of low-boiling hydrocarbons is proposed in the prior publication. To the extent that a "reservoir" is mentioned in the prior publication, this reservoir merely serves to maintain a required liquid level inside the pump
25 chamber. This reservoir does not communicate with the intake area of the pump, but only with a pressure outlet provided at a certain location on the actual pump housing, and with the discharge stub of the pump.

The goal of the invention is to improve the pumping method
30 described at the outset as well as the multi-phase screw shaft pump described at the outset in such fashion that neither extremely high gas content nor prolonged phases of dry running result in interruption of feed or in damage.

According to one aspect of the invention, there is provided a pumping method for operating a multi-phase screw pump with at least one feed screw surrounded by a housing that contains at least one inlet, and at least one outlet, said feed screw having a pressure side, said method comprising steps of:

drawing a medium into said inlet in a continuous low-pulsed feed stream in a direction parallel to a screw shaft of said feed screw;

expelling said medium continuously at the outlet;

separating a liquid phase of said medium from a gas phase of said medium, wherein the medium flow emerging from the pressure side of said feed screw has its flow direction diverted;

removing a partial liquid volume flow from the liquid phase;

recycling and metering said partial liquid volume flow into the inlet; and

recombining a surplus liquid volume flow of said partial liquid volume flow with the gas phase in the outlet,

wherein approximately 3% of a normal delivery flow is kept in said partial liquid volume flow.

3 / 1

According to another aspect of the invention, there is provided a multi-phase screw pump comprising:

at least one feed screw surrounded by a housing, said
5 housing having at least one inlet and at least one outlet;

a suction chamber connected to said inlet and being located in a first flow direction relative to said feed screw;

10 a pressure chamber connected to said outlet and being located in a second flow direction, opposite said first flow direction relative to said feed screw, wherein said pressure chamber includes means for separating a respective liquid
15 phase from the gas phase of a medium flow emerging from said feed screw in said second flow direction into a liquid phase and a gas phase, and a lower section for receiving at least a partial volume of the liquid phase;

a liquid bypass line connected to said lower section,
20 wherein a flowrate in said lower section is approximately zero, said bypass line being connected to said suction chamber and forming, together with said feed screw, a closed bypass for a liquid volume required for permanent sealing of said pump; and

25 flow guide means positioned within said pressure chamber for reinforcing the separation of said liquid phase and said gas phase in said pressure chamber.

With regard to the pump, the stated goal is achieved according to the invention by virtue of the fact that a liquid bypass line is connected to a lower portion of this pressure chamber, in which the flowrate tends toward zero, said bypass line communicating with the suction chamber and, together with the delivery elements, forming a closed bypass for a liquid volume required for permanent sealing.

According to the essential idea of the invention, therefore, assurance must be provided that sufficient liquid remains in the pump for safely performing its functions even at high gas rates or limited dry running, and is not expelled. This liquid remaining in the pump housing is intended to wet the shaft seals permanently and sufficiently, possibly in mist form.

According to the invention, therefore, the delivery flow emerging from the feed screw on the pressure side is separated into its liquid phase and its gas phase, with the phase separation existing in the feed flow remaining constant, i.e., the percentage of the phase in the total volume must not be altered by separation. It is also proposed according to the invention to split off a certain partial volume from the liquid phase separated on the pressure side, and to keep it permanently circulating through the pump by returning it to the intake area, in order to ensure a sufficient gap seal there as well if the delivery medium drawn in has only a very small liquid phase or none at all.

The features according to the invention are also not suggested by GB 2 227 057 A, since it can be demonstrated experimentally that the condensate obtained according to the teaching of this prior publication cannot be recycled as a fluid or kept in circulation, since the condensate returns to the gas phase even before it enters the intake area, because of the pressure drop that this causes. Hence the condensate that is obtained is not suitable for gap sealing and heat removal according to the invention.

10 The degree of separation required to achieve the stated goal and the volume of liquid to be kept in circulation can be determined on the basis of the housing and flow configurations. The metering of the liquid circulation can take place as a function of the pump differential pressure.

15 However, it is also possible to connect a metering pump or a temperature-controlled valve in the liquid bypass line. It is advantageous in this regard if about 3% of the normal delivery flow is kept in circulation.

In order to facilitate separation of the liquid phase from the gas phase of the delivered medium in the pressure chamber, it is advantageous for the flowrate of the medium emerging from the feed screw on the discharge side to be reduced. This can be accomplished in the device by virtue of the fact that the pressure chamber has a cross section that increases as viewed in the direction of the through flow of the medium. In addition, flow guide means can be provided in the pressure chamber that reinforce separation and/or guide the liquid phase of the medium emerging from the feed screw against the associated shaft seal and then the contact area of the liquid bypass line.

30 Further features of the invention will be evident in the subclaims and will be described in greater detail in conjunction with an embodiment.

In the drawing, two embodiments of the invention are shown as examples.

Figure 1 shows a screw pump in a lengthwise section;
Figure 2 is a schematic diagram of a cross section through a
5 pump housing of a modified design; and
Figure 3 is the same as Figure 2 but shows a cross section
through a known pump housing (prior art).

The screw pump shown in Figure 1 has two pairs of feed screws as delivery elements, said screws meshing with one another
10 without contact and turning in opposite directions, said screws each comprising a right-hand feed screw 1 and a left-hand feed screw 2. This two-stream arrangement compensates for axial thrust. The meshing feed screws, together with housing 3 surrounding them, form individually enclosed feed
15 chambers. When turned by a drive shaft 7, these chambers move continuously and parallel to shafts 7, 8 from the intake to the discharge side. The rotational direction of drive shaft 7 determines the feed direction of the feed chambers.

The torque transfer from the drive shaft to the driven shafts
20 takes place through a gear transmission 4 located outside pump housing 3, the setting of said transmission ensuring zero-contact operation of the feed elements.

Pump housing 3 has an intake stub 5 and a discharge stub 6. The latter can preferably be provided on the top of pump
25 housing 3. In this case, the drawing shows a perpendicular central section through the screw pump. However, the drawing can also be a horizontal section in which intake and discharge stubs 5 and 6 are opposite one another laterally, while the two shafts 7 and 8 are arranged side-by-side in a common
30 horizontal plane.

Medium 9 that flows into the pump through intake stub 5 is fed in pump housing 3 in two partial streams to the respective

central suction chambers 10 located upstream from the associated feed screws 1 or 2. A pressure chamber 11 is located downstream from each of these feed screws 1, 2, said chamber being sealed axially from the exterior by shaft seals 12, which serve to seal outer bearing 13. Pressure chamber 11 has a cross section that increases as viewed in the direction of flow of medium 9.

If we assume that the drawing shows a vertical lengthwise central section, a liquid bypass line 14 is connected at the lowest point in pressure chamber 11, said line communicating with suction chamber 10. The partial flow volume that is separated on the intake side from the delivered liquid-gas mixture and is fed back into the intake area with metering, is marked by arrow 15 and is returned as a liquid circulation from suction chamber 10 into pressure chamber 11.

It is clear from the drawing that the liquid phase of medium 9 emerging from feed screw 1, 2 is guided against the associated shaft seal 12 and then reaches the connecting area of liquid bypass line 14 by gravity. The increase in the flow cross section of pressure chamber 11 causes the flowrate of the emerging medium to decrease, so that separation of the liquid phase from the delivered mixture is promoted. The feed of the liquid phase into the connecting area of liquid bypass line 14 can be favored by flow guide means 17 shown only schematically in the drawing, said means also being able to serve to support separation as well as regulation of the liquid level in pressure chamber 11.

The connection of liquid bypass line 14 to pressure chamber 11 should be located sufficiently low that a permanent liquid circulation (avoiding the entry of gas) is ensured. This degree of separation can be determined on the basis of the housing and flow configuration. It has proven advantageous in this regard to keep approximately 3% of the normal delivery flow in the liquid circulation. The liquid level thus ensured

in pump housing 3 or in pressure chamber 11 can as a rule be below shafts 7 and 8. Wetting of shaft seals 12 as a consequence of this direct flow is sufficient as a rule for adequate lubrication of shaft seals 12. Permanent irrigation of shaft seals 12 is required only with particularly sensitive sealing materials. In this case, a horizontal arrangement of the two shafts 7 and 8 next to one another and a correspondingly higher liquid level in pressure chamber 11 is recommended.

Provision of the delivery elements with sufficient gap-sealing liquid is also ensured, thanks to liquid bypass line 14 according to the invention, when the two shafts 7 and 8 are located one above the other in a vertical plane. The liquid adhering to the tooth crest of the lower feed screw is flung into the tooth gullet of the upper feed screw and then migrates toward the tooth crest along the flanks of the tooth, under centrifugal force. The mesh and tooth crest remain permanently wetted as a result. This minimum wetting of the dead-volume space suffices to maintain delivery.

A suitably dimensioned diaphragm 18 can be connected in liquid bypass line 14 to meter the liquid circulation.

Since the liquid circulation provided according to the invention is advantageous only when the liquid phase of the medium to be conveyed is not sufficient, this liquid circulation can be connected as needed, for example by a temperature control.

Figure 3 is a schematic diagram of a cross section through a conventional pump housing, likewise intended to incorporate two feed screw pairs turning in opposite directions in accordance with Figure 1. In this case, liquid delivery takes place, as viewed axially, in each case from the exterior to the middle of the pump into a pressure chamber 11 which in each case is connected directly downstream from the feed

screws, said chamber making a transition to a pressure slot 16 located approximately centrally in the pump housing. The flowrate in pressure chamber 11 and pressure slot 16 at the center of the pump is approximately 3 to 8 m/s in such
5 embodiments. For gas delivery, the residual liquid in pressure chamber 11 is soon expelled by entrainment in the gas and evaporation by the heat of compression and friction.

On the other hand, the design according to the invention shown in Figure 2 shows that pressure chamber 11 in pump housing 3
10 also extends below the feed screw pair as well as the delivery chambers formed by them, together with the housing surrounding them. Pressure chamber 11 is designed so that the flowrate of the delivery current emerging on the pressure side from the feed screw tends toward zero in its lower part. As a result,
15 the liquid and gas phases are separated because of the density differential.

The configuration shown in Figure 2 is possible with a central or a lateral pressure chamber.

CLAIMS:

1. A pumping method for operating a multi-phase screw pump
5 with at least one feed screw surrounded by a housing
that contains at least one inlet, and at least one
outlet, said feed screw having a pressure side, said
method comprising steps of:
- 10 drawing a medium into said inlet in a continuous low-
pulsed feed stream in a direction parallel to a screw
shaft of said feed screw;
- expelling said medium continuously at the outlet;
- 15 separating a liquid phase of said medium from a gas
phase of said medium, wherein the medium flow emerging
from the pressure side of said feed screw has its flow
direction diverted;
- 20 removing a partial liquid volume flow from the liquid
phase;
- recycling and metering said partial liquid volume flow
25 into the inlet; and
- recombining a surplus liquid volume flow of said
partial liquid volume flow with the gas phase in the
outlet,
- 30 wherein approximately 3% of a normal delivery flow is
kept in said partial liquid volume flow.

2. A pumping method according to claim 1, wherein the metering of the partial liquid volume flow takes place as a function of a differential pressure of the pump.

5

3. A pumping method according to claim 1, wherein a flow rate of a medium flow emerging from the pressure side of said feed screw is reduced.

10 4. A pumping method according to claim 1, wherein said multi-phase screw pump further includes at least two feed screws of said at least one feed screw arranged for double flow and each of said feed screws including outside bearings, a shaft seal and a suction side, the
15 method further comprising the step of:

delivering two partial flows from the suction side of each of said feed screws in opposite delivery directions directed away from one another to the respective
20 pressure side of each of said feed screws and to each respective shaft seal.

5. A multi-phase screw pump comprising:

25 at least one feed screw surrounded by a housing, said housing having at least one inlet and at least one outlet;

a suction chamber connected to said inlet and being
30 located in a first flow direction relative to said feed screw;

a pressure chamber connected to said outlet and being located in a second flow direction, opposite said first flow direction relative to said feed screw, wherein said pressure chamber includes means for separating a
5 respective liquid phase from the gas phase of a medium flow emerging from said feed screw in said second flow direction into a liquid phase and a gas phase, and a lower section for receiving at least a partial volume of the liquid phase;

10

a liquid bypass line connected to said lower section, wherein a flowrate in said lower section is approximately zero, said bypass line being connected to said suction chamber and forming, together with said
15 feed screw, a closed bypass for a liquid volume required for permanent sealing of said pump; and

20

flow guide means positioned within said pressure chamber for reinforcing the separation of said liquid phase and
said gas phase in said pressure chamber.

25

6. A multi-phase screw pump according to claim 5, wherein said liquid bypass line includes a flow cross section shaped as a function of the differential
pressure of the pump.

30

7. A multi-phase screw pump according to claim 5, further comprising a metering orifice located within said liquid bypass line.

8. A multi-phase screw pump according to claim 5, further comprising a temperature-controlled valve

located within said liquid bypass line.

9. A multi-phase screw pump according to claim 5,
wherein said housing includes a top positioned opposite
5 said lower section of said pressure chamber and said
outlet is located on said top of said housing.

10. A multi-phase screw pump according to claim 5,
wherein said liquid bypass line is connected to a lowest
10 point of said pressure chamber.

11. A multi-phase screw pump according to claim 5,
further comprising:

15 two shafts located within said housing connected
parallel to one another, said shafts each including two
feed screws of said at least one feed screw, said shafts
turning in opposite directions and each of said shafts
having an outside bearing, wherein said medium flow
20 travels through said inlet to said housing and to said
suction chamber in two partial streams, wherein said
suction chamber is located centrally within said
housing; and

25 a shaft seal connected to each shaft, said pressure
chamber being sealed axially by said shaft seal.

12. A multi-phase screw pump according to claim 5,
wherein said pressure chamber includes a cross section
30 that increases in said second flow direction.

13. A multi-phase screw pump according to claim 5, further comprising a suitably dimensioned orifice positioned within said liquid bypass line for metering a flow of said liquid volume.

5

14. A multi-phase screw pump comprising:

at least one feed screw surrounded by a housing, said housing having at least one inlet and at least one outlet;

10

a suction chamber connected to said inlet and being located in a first flow direction relative to said feed screw;

15

a pressure chamber connected to said outlet and being located in a second flow direction, opposite said first flow direction, relative to said feed screw, wherein said pressure chamber includes means for separating a respective liquid phase from the gas phase of a medium flow emerging from said feed screw in said second flow direction into a liquid phase and a gas phase, and a lower section for receiving at least a partial volume of the liquid phase;

20

25

a liquid bypass line connected to said lower section, wherein a flowrate in said lower section is approximately zero, said bypass line being connected to said suction chamber and forming, together with said feed screw, a closed bypass for a liquid volume required for permanent sealing of said pump;

30

two shafts located within said housing connected parallel to one another, said shafts each including two feed screws of said at least one feed screw, said shafts turning in opposite directions and each of said shafts having an outside bearing, wherein said medium flow travels through said inlet to said housing and to said suction chamber in two partial streams, wherein said suction chamber is located centrally within said housing;

5

a shaft seal connected to each shaft, said pressure chamber being sealed axially by said shaft seal; and

10

flow guide means positioned within said pressure chamber, said flow guide means for guiding the liquid phase of said medium flow emerging from said feed screw against the shaft seal and to the liquid bypass line.

15

15. A multi-phase screw pump comprising:

20

at least one feed screw surrounded by a housing, said housing having at least one inlet and at least one outlet;

25

a suction chamber connected to said inlet and being located in a first flow direction relative to said feed screw;

30

a pressure chamber connected to said outlet and being located in a second flow direction, opposite said first flow direction, relative to said feed screw, wherein said pressure chamber includes means for separating a

respective liquid phase from the gas phase of a medium
flow emerging from said feed screw in said second flow
direction into a liquid phase and a gas phase, and a
lower section for receiving at least a partial volume of
5 the liquid phase;

a liquid bypass line connected to said lower section,
wherein a flowrate in said lower section is
approximately zero, said bypass line being connected to
10 said suction chamber and forming, together with said
feed screw, a closed bypass for a liquid volume required
for permanent sealing of said pump; and

flow guide means positioned within said pressure chamber
15 for regulating a level of said liquid phase in pressure
chamber.

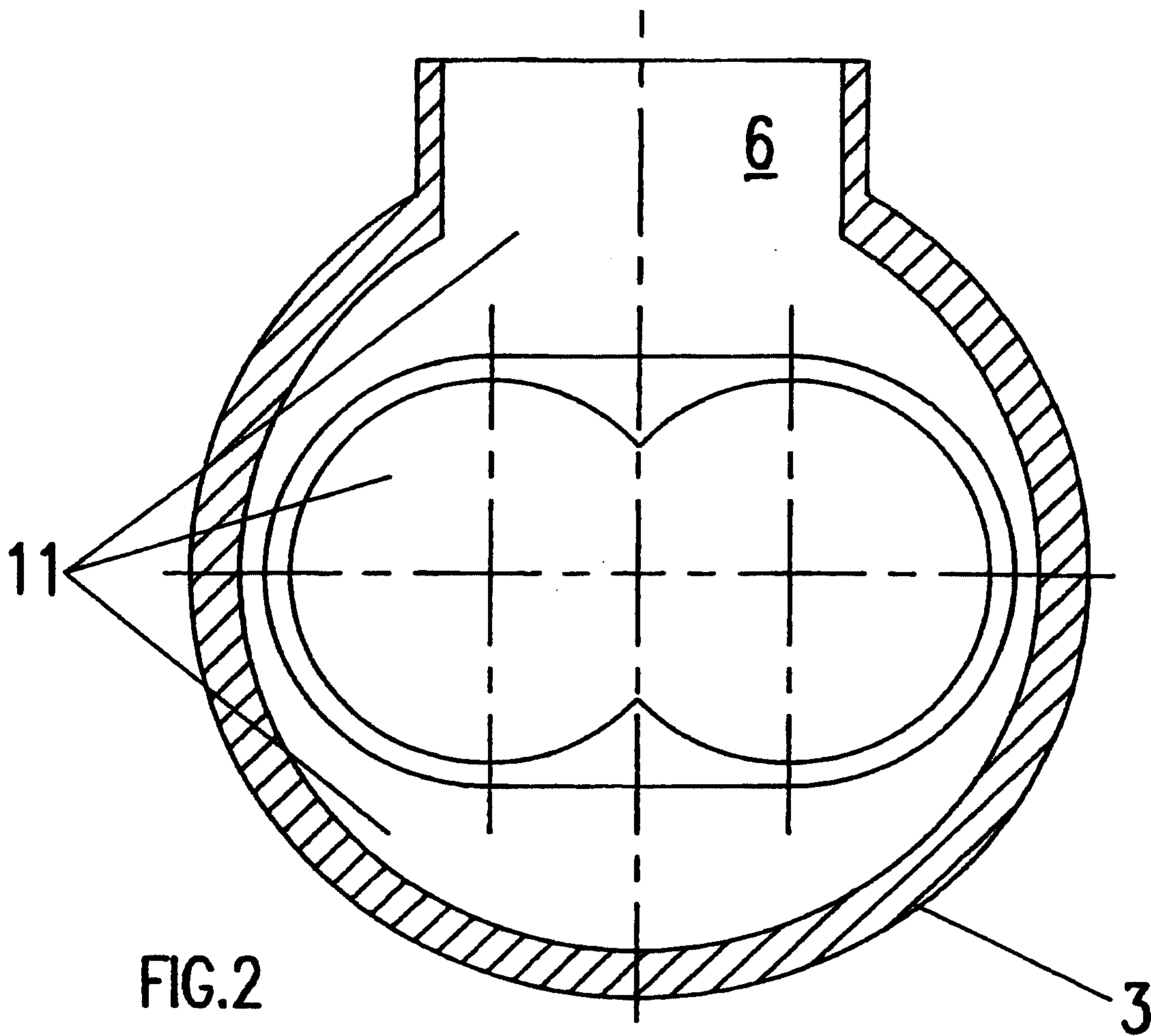

FIG. 2

PRIOR ART

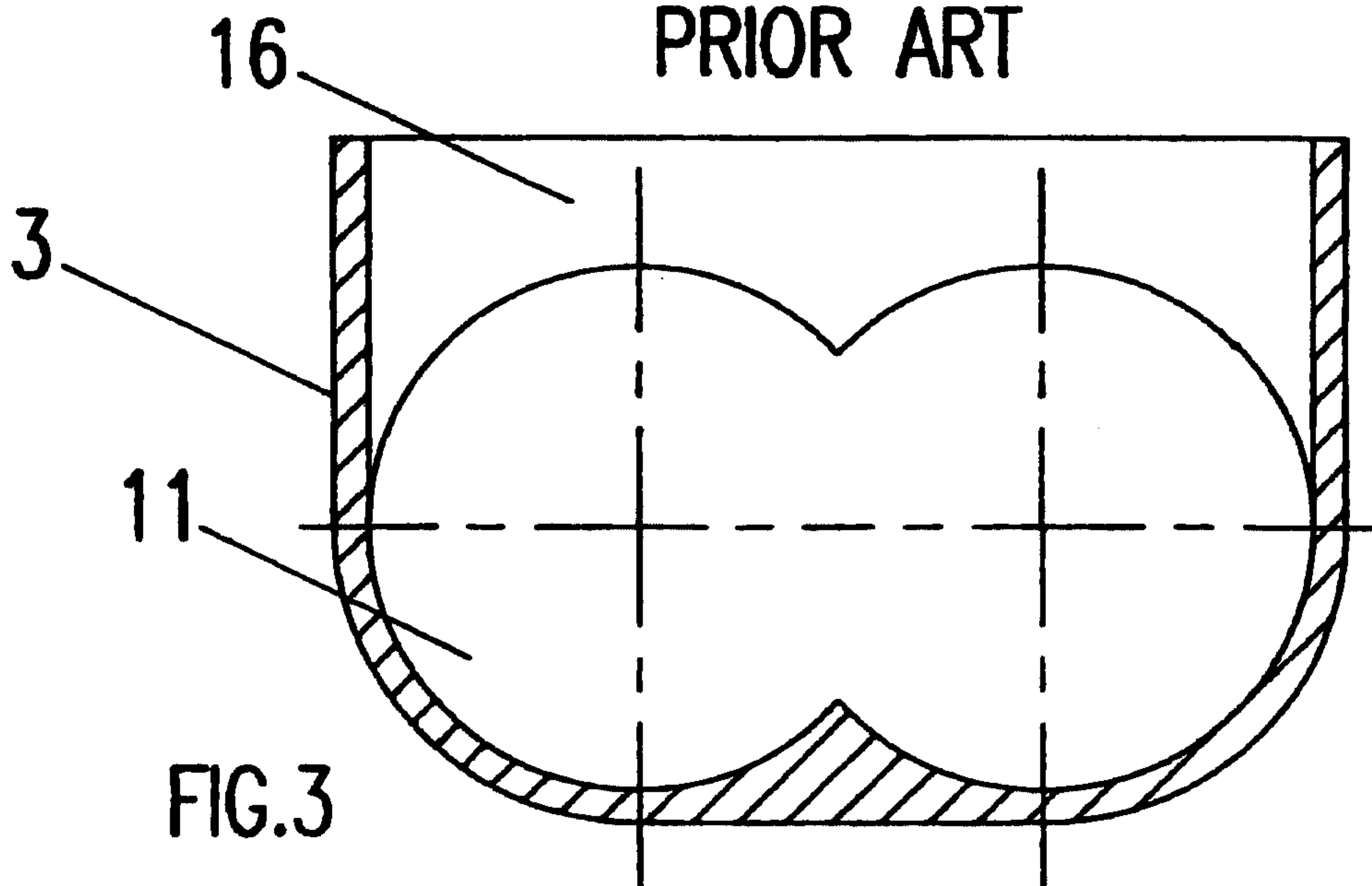

FIG. 3

