

W. WORMALD & E. DOBSON.
SEWING-MACHINE.

No. 169,881.

Patented Nov. 9, 1875.

FIG. 1.

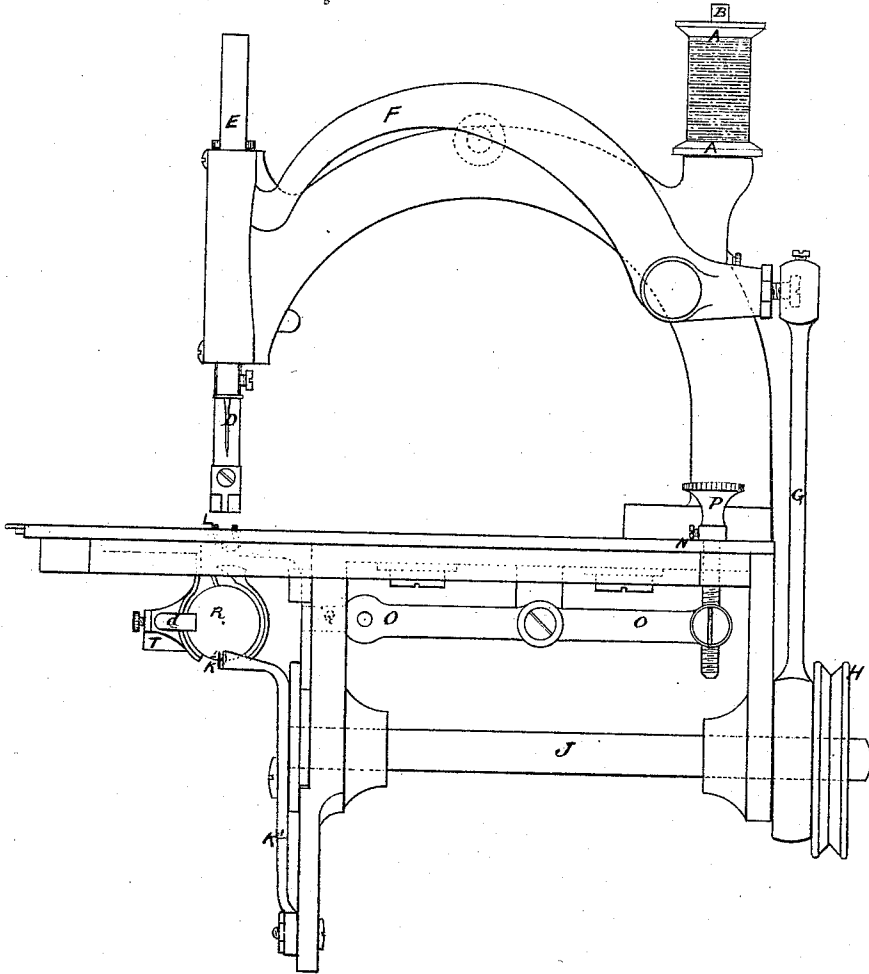

Inventors.

*William Wormald
Edmund Dobson*

Witnesses.

*William Cykes Ward
John William Taster*

W. WORMALD & E. DOBSON.

SEWING-MACHINE.

No. 169,881.

Patented Nov. 9, 1875.

FIG. 2.

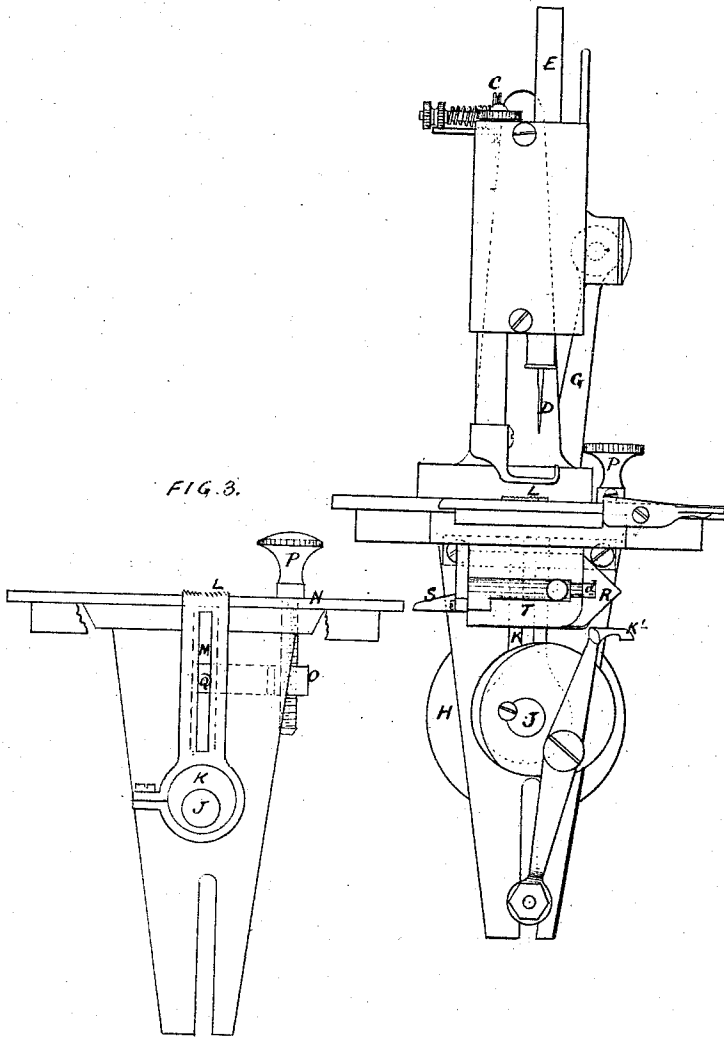

Inventors

William Wormald

Edmund Dobson

Witnesses

William Sykes Ward

John William Taster

W. WORMALD & E. DOBSON.
SEWING-MACHINE.

No. 169,881.

Patented Nov. 9, 1875.

FIG. 4.

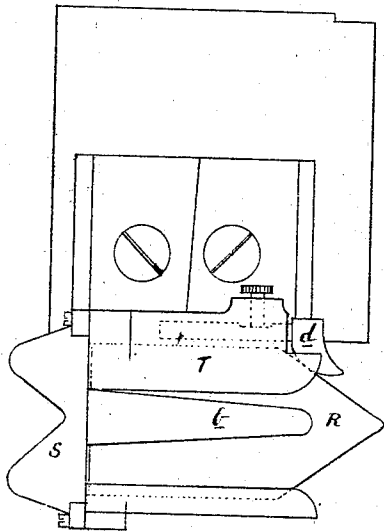

FIG. 6.

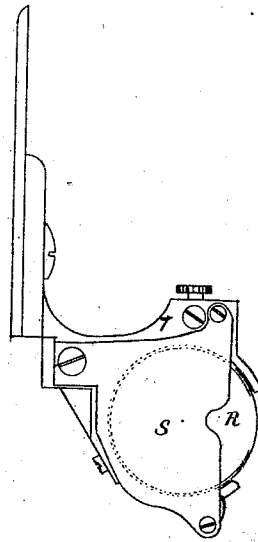

FIG. 5.

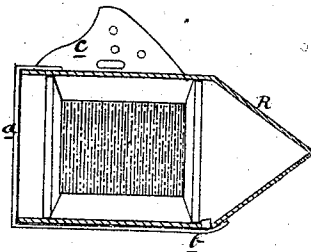

FIG. 7.

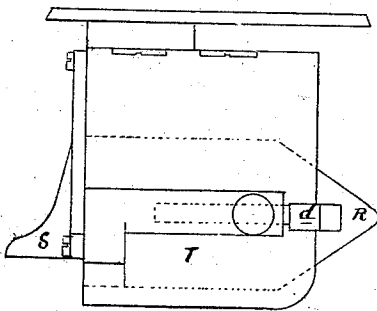
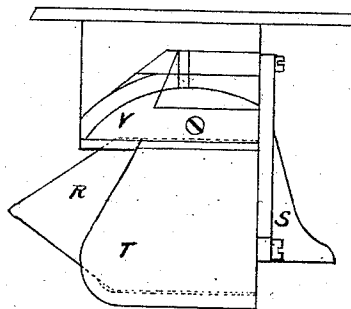

FIG. 8.



Inventors,

*William Wormald
Edmund Dobson*

Witnesses.

*William Sykes Wood
John William Fisher*

UNITED STATES PATENT OFFICE.

WILLIAM WORMALD AND EDMUND DOBSON, OF LEEDS, ENGLAND.

IMPROVEMENT IN SEWING-MACHINES.

Specification forming part of Letters Patent No. 169,881, dated November 9, 1875; application filed February 13, 1875.

To all whom it may concern:

Be it known that we, WILLIAM WORMALD and EDMUND DOBSON, of Leeds, in the county of York and Kingdom of England, have invented certain Improvements in Sewing-Machines, of which the following is a specification:

This invention relates to that class of sewing-machines in which the looping-hook carries the thread around the spool-case and holder, and has for its object such improvements as will enable the same machine to produce the lock-stitch from two ordinary reels of thread, without necessitating the rewinding of the thread into smaller quantities upon temporary reels or other apparatus to suit the machine, as heretofore; also, to produce the cable-stitch from two ordinary reels of thread; also, to produce the chain-stitch with one thread, and to effect simplicity in construction; and consists, essentially, in the peculiar construction and arrangement of the spool-case holder, provided with a removable barb-shaped piece of metal, the inclination of which facilitates the passage of the thread to the back of the needle, and which, when producing the cable or single chain or loop stitch, is removed. The invention further consists in the employment, in conjunction with the spool-case holder, of an adjustable locking-bolt, having its end enlarged, by means of which the spool-case is held in position in the holder, and which may be adjusted to allow of the passage of thread of varying thickness.

But that our invention may be fully understood, we will proceed to describe the same in detail by aid of the accompanying drawings, in which similar letters of reference are employed to indicate corresponding parts wherever they may occur.

Figure 1 is a side elevation of a machine constructed according to our invention. Fig. 2 is a front view of the same; and Figs. 3, 4, 5, 6, 7, and 8 are detail views.

In order to produce the lock-stitch, we have one reel of thread, A, placed upon a stud, B, fixed on the top of the machine, as usual, and the thread is passed through or between two washers or disks, C, from left to right. The vertical needle D is made flat on one side, thus forming a shoulder thereon, and the

needle-bar is constructed to receive the needle always in its proper position. The reciprocating motion of the needle-bar E is derived from a lever, F, and connecting link or rod G, working upon an eccentric pulley, H, fixed upon a horizontal rotary shaft, J. On the other end of this shaft is an eccentric disk or stud-plate, K, for working the feeder L, which gives it both a vertical and horizontal movement, for the purpose of carrying the work along. The movement of the feeder is regulated by means of a groove or slot, M, being cut in the vertical part thereof; also, a groove being cut in the stationary body N of the machine, in which rests the end of a lever, O, which is capable of being moved up and down by means of a screw, P, passed through the other end thereof. On the first-mentioned end of the lever is a pin, Q, which serves as a fulcrum or pivot for the feeder L, and by raising and lowering this pivot, a longer or shorter stroke is effected, and thus the length of the stitch is determined. To the aforesaid disk is connected a hook, K', working close to the needle, and capable of entering the loop made by the rising of the needle. This hook is curved, and describes an ellipse, or nearly so, in traveling around the spool-case and holder, and carries the thread in the loop around said spool-case R, or case containing the second reel of thread, one end of which is formed conical for the loop to pass easily on to the case, and thence forward to the needle, when it enters the second loop and draws up the thread of the first, and so forms the lock-stitch. This conical spool-case R is provided at one end with a lid, a, to which is affixed a spring, having a stud or pin, b, at its extremity, which, when the lid is in position, fits into and rests in an aperture formed in the spool-case R for its reception, and this holds the lid securely in position. The spool-case R is further provided with a vertical, triangular, or conical metal plate, c, which has a series of holes formed therein at varying distances from each other, and by passing the thread through one of them, either higher up or lower down, the tension of said thread is regulated as required. The spool-case is held in its proper position, first, by a curved metal plate, s, at the back of the spool-case holder

T, which also serves to disengage the thread from the hook K', after the same has passed around the shuttle. The spool-case R is further secured in position at its front end by means of a locking-bolt, *d*, which fits or rests in a socket formed on the spool-case holder T, as shown by the drawings. This bolt is provided at one end with an enlarged curved head, formed at right angles, or nearly so, to said bolt, which is held in position by means of a set-screw. By this arrangement the bolt *d* is made adjustable longitudinally to the spool-case, and by sliding it in or out more or less in the socket, it may be readily adjusted for the passage of thread of varying thicknesses. When the bolt *d* is adjusted in its proper position, the enlargement or head projects in front of the spool-case R, and effectually prevents the same from slipping out. For the purpose of forming the lock-stitch, we secure to the side of the spool-case holder a barb-shaped piece, V, which forms an incline and facilitates the passage of the thread to the back of the needle. In order to produce the cable-stitch we remove the barb-shaped piece V before mentioned, and then, instead of the loop being carried past the needle-groove before the needle has penetrated a second time to its lowest point, (as is the case in making the lock-stitch,) the loop is held on one side by the end of the spool-case holder T until the needle has passed down a second

time and entered the first loop. The second loop is then carried forward by the hook K', which draws up the thread of the first loop as before, and so produces the cable-stitch. In producing the single chain or loop stitch by the same machine, we proceed in the same manner as before described, except that the under thread used for the lock-stitch and double chain-stitch is not used. The case may remain in its place and the reel of thread in the case. The barb-shaped piece V is also removed.

Having described our invention, what we claim, and desire to secure by Letters Patent, is—

1. The combination of the spool-case holder T and spool-case R with the adjustable bolt *d*, all constructed and operating substantially as and for the purposes specified.

2. In a sewing-machine capable of producing the lock-stitch, cable-stitch, and loop or chain stitch, the combination of the spool-case holder T, curved metal plate *s*, the conical spool-case R, constructed substantially as described, and the adjustable locking-bolt *d*, with the removable barb-shaped piece V, all constructed to operate as set forth.

WILLIAM WORMALD.
EDMUND DOBSON.

Witnesses:

WILLIAM SYKES WARD,
JOHN WILLIAM TASKER.