



(86) Date de dépôt PCT/PCT Filing Date: 2016/03/02
 (87) Date publication PCT/PCT Publication Date: 2016/09/09
 (85) Entrée phase nationale/National Entry: 2017/08/28
 (86) N° demande PCT/PCT Application No.: EP 2016/054351
 (87) N° publication PCT/PCT Publication No.: 2016/139215
 (30) Priorité/Priority: 2015/03/02 (EP15000587.4)

(51) Cl.Int./Int.Cl. *A61M 5/315* (2006.01),
A61M 5/28 (2006.01)
 (71) Demandeur/Applicant:
FRESENIUS KABI AUSTRIA GMBH, AT
 (72) Inventeurs/Inventors:
BALDAUF, WOLFGANG, AT;
HEINRICH, JORG, DE;
ZAUNER, CHRISTOPH, AT
 (74) Agent: BERESKIN & PARR LLP/S.E.N.C.R.L.,S.R.L.

(54) Titre : TIGE DE PISTON COMPRENANT AU MOINS TROIS ELEMENTS CYLINDRIQUES POUR UNE SERINGUE PREREMPLIE

(54) Title: PLUNGER ROD COMPRISING AT LEAST THREE ANNULAR ELEMENTS FOR A PREFILLED SYRINGE

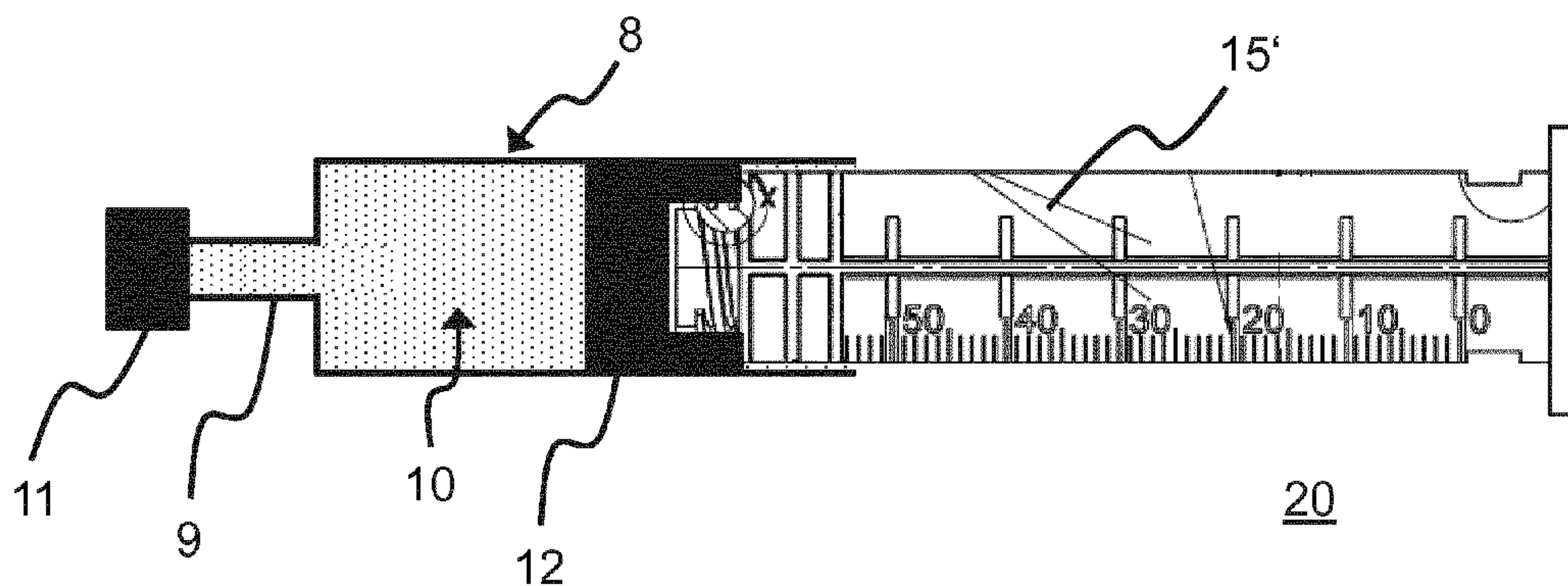

Fig. 1.b

(57) **Abrégé/Abstract:**

The invention relates to a plunger rod for a syringe body which is prefilled with a medical fluid and to a prefilled syringe comprising such a plunger rod. The prefilled syringe (20) comprises the following components: a syringe body (8) filled with a medical fluid (10), which has a nozzle (9) at a front side, the nozzle being closed with a cap (11), and which is closed at a rear side with a displaceable plunger (12); and a plunger rod (15', 15", 15"', 15''') that can be inserted into the syringe body (8) via the rear side, said plunger rod having a connecting portion (1) at a front side, via which the plunger rod (15', 15", 15"', 15''') can be connected to the plunger (12). According to the invention, at least three annular elements (2a, 2b, 2c), which extend at least in some sections about a longitudinal axis of the plunger rod (15', 15", 15"', 15'''), are arranged on a rear side of the connecting portion (1) on the plunger rod (15', 15", 15"', 15''') in such a manner that they are located in the syringe body when the plunger rod (15', 15", 15"', 15''') is fully connected to the plunger (12). The three annular elements support a coaxial connection of the plunger rod to the plunger positioned in the syringe. During the connection of the plunger rod to the plunger, the three annular elements allow the user a haptic and/or acoustic control whether he connects the plunger rod properly to the plunger.

(12) NACH DEM VERTRAG ÜBER DIE INTERNATIONALE ZUSAMMENARBEIT AUF DEM GEBIET DES PATENTWESENS (PCT) VERÖFFENTLICHTE INTERNATIONALE ANMELDUNG

(19) Weltorganisation für geistiges

Eigentum

Internationales Büro

(43) Internationales

Veröffentlichungsdatum

9. September 2016 (09.09.2016)



(10) Internationale Veröffentlichungsnummer

WO 2016/139215 A1

(51) Internationale Patentklassifikation:

A61M 5/315 (2006.01) A61M 5/28 (2006.01)

(21) Internationales Aktenzeichen: PCT/EP2016/054351

(22) Internationales Anmeldedatum:

2. März 2016 (02.03.2016)

(25) Einreichungssprache:

Deutsch

(26) Veröffentlichungssprache:

Deutsch

(30) Angaben zur Priorität:

15000587.4 2. März 2015 (02.03.2015) EP

(71) Anmelder: FRESENIUS KABI AUSTRIA GMBH [AT/AT]; Hafnerstraße 36, 8055 Graz (AT).

(72) Erfinder: BALDAUF, Wolfgang; Gnaningerstraße 28, 8072 Fernitz (AT). HEINRICH, Jörg; Almrauschstraße 10, 82031 Grünwald (DE). ZAUNER, Christoph; Am Wald, 8071 Hausmannstätten (AT).

(74) Anwalt: FRESENIUS KABI DEUTSCHLAND GMBH; Patent Department - Pharmaceuticals Division, Borkenberg 14, 61440 Oberursel (DE).

(81) Bestimmungsstaaten (soweit nicht anders angegeben, für jede verfügbare nationale Schutzrechtsart): AE, AG, AL, AM, AO, AT, AU, AZ, BA, BB, BG, BH, BN, BR, BW, BY, BZ, CA, CH, CL, CN, CO, CR, CU, CZ, DE, DK,

DM, DO, DZ, EC, EE, EG, ES, FI, GB, GD, GE, GH, GM, GT, HN, HR, HU, ID, IL, IN, IR, IS, JP, KE, KG, KN, KP, KR, KZ, LA, LC, LK, LR, LS, LU, LY, MA, MD, ME, MG, MK, MN, MW, MX, MY, MZ, NA, NG, NI, NO, NZ, OM, PA, PE, PG, PH, PL, PT, QA, RO, RS, RU, RW, SA, SC, SD, SE, SG, SK, SL, SM, ST, SV, SY, TH, TJ, TM, TN, TR, TT, TZ, UA, UG, US, UZ, VC, VN, ZA, ZM, ZW.

(84) Bestimmungsstaaten (soweit nicht anders angegeben, für jede verfügbare regionale Schutzrechtsart): ARIPO (BW, GH, GM, KE, LR, LS, MW, MZ, NA, RW, SD, SL, ST, SZ, TZ, UG, ZM, ZW), eurasisches (AM, AZ, BY, KG, KZ, RU, TJ, TM), europäisches (AL, AT, BE, BG, CH, CY, CZ, DE, DK, EE, ES, FI, FR, GB, GR, HR, HU, IE, IS, IT, LT, LU, LV, MC, MK, MT, NL, NO, PL, PT, RO, RS, SE, SI, SK, SM, TR), OAPI (BF, BJ, CF, CG, CI, CM, GA, GN, GQ, GW, KM, ML, MR, NE, SN, TD, TG).

Veröffentlicht:

— mit internationalem Recherchenbericht (Artikel 21 Absatz 3)

— vor Ablauf der für Änderungen der Ansprüche geltenden Frist; Veröffentlichung wird wiederholt, falls Änderungen eingehen (Regel 48 Absatz 2 Buchstabe h)

(54) Title: PLUNGER ROD COMPRISING AT LEAST THREE ANNULAR ELEMENTS FOR A PREFILLED SYRINGE

(54) Bezeichnung : KOLBENSTANGE MIT WENIGSTENS DREI RINGELEMENTEN FÜR EINE VORGEFÜLLTE SPRITZE

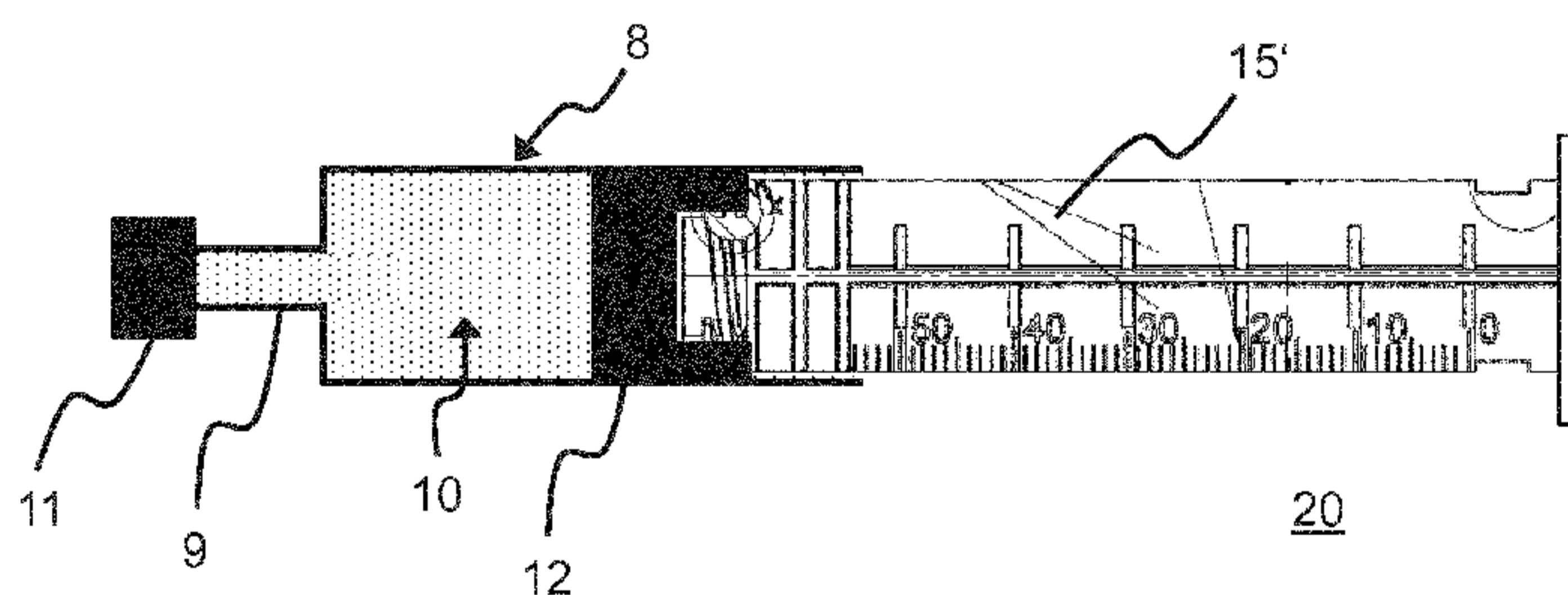

Fig. 1.b

(57) **Abstract:** The invention relates to a plunger rod for a syringe body which is prefilled with a medical fluid and to a prefilled syringe comprising such a plunger rod. The prefilled syringe (20) comprises the following components: a syringe body (8) filled with a medical fluid (10), which has a nozzle (9) at a front side, the nozzle being closed with a cap (11), and which is closed at a rear side with a displaceable plunger (12); and a plunger rod (15', 15", 15"', 15''') that can be inserted into the syringe body (8) via the rear side, said plunger rod having a connecting portion (1) at a front side, via which the plunger rod (15', 15", 15"', 15''') can be connected to the plunger (12). According to the invention, at least three annular elements (2a, 2b, 2c), which extend at least in some sections about a longitudinal axis of the plunger rod (15', 15", 15"', 15''') in such a manner that they are located in the syringe body when the plunger rod (15', 15", 15"', 15''') is fully connected to the plunger (12). The three annular elements support a coaxial connection of the plunger rod to the plunger positioned in the syringe. During the connection of the plunger rod to the plunger, the three annular elements allow the user a haptic and/or acoustic control whether he connects the plunger rod properly to the plunger.

(57) Zusammenfassung:

[Fortsetzung auf der nächsten Seite]

WO 2016/139215 A1 

Die Erfindung betrifft eine Kolbenstange für einen mit einer medizinischen Flüssigkeit vorgefüllten Spritzenkörper und eine vorgefüllte Spritze umfassend eine solche Kolbenstange. Die vorgefüllte Spritze (20) umfasst die folgenden Komponenten: einen mit einer medizinischen Flüssigkeit (10) befüllten Spritzenkörper (8), der an einer Vorderseite eine Düse (9) aufweist, die mit einer Kappe (11) verschlossen ist, und der an einer Rückseite mit einem verschiebbaren Kolben (12) verschlossen ist, und eine über die Rückseite in den Spritzenkörper (8) einführbare Kolbenstange (15', 15", 15"', 15'''), die an einer Vorderseite einen Verbindungsabschnitt (1) aufweist, über den die Kolbenstange (15', 15", 15"', 15''') mit dem Kolben (12) verbindbar ist, wobei an einer Rückseite des Verbindungsabschnitts (1) wenigstens drei Ringelemente (2a, 2b, 2c), die sich zumindest abschnittsweise um eine Längsachse der Kolbenstange (15', 15", 15"', 15''') erstrecken, so an der Kolbenstange (15', 15", 15"', 15''') angeordnet sind, dass sie sich, wenn die Kolbenstange (15', 15", 15"', 15''') vollständig mit dem Kolben (12) verbunden ist, in dem Spritzenkörper befinden. Die drei Ringelemente unterstützen ein koaxiales Verbinden der Kolbenstange mit dem in der Spritze positionierten Kolben. Die drei Ringelemente ermöglichen dem Anwender beim Verbinden der Kolbenstange mit dem Kolben eine haptische und/oder akustische Kontrolle, ob er die Kolbenstange ordnungsgemäß mit dem Kolben verbindet.

WO 2016/139215

PCT/EP2016/054351

**Plunger rod comprising at least three annular elements
for a prefilled syringe**

The invention relates to a plunger rod for a syringe body
5 prefilled with a medical fluid and to a syringe including
the plunger rod and the syringe body prefilled with the
medical fluid.

WO 2014/053560 A1 discloses a syringe prefilled with a
10 medical fluid. In one embodiment, the plunger rod and the
syringe body are mounted located side by side in an over
pack. To use the syringe, the plunger rod and the syringe
body have first to be removed out of the over pack. The
15 plunger rod is then screwed into the plunger closing the
rear end of the syringe body. The content of the named
patent application is incorporated fully into the present
patent application by reference.

The object underlying the invention is to provide an
20 improved plunger rod. The inserting, in particular the
screwing, of the plunger rod into the plunger is to be
improved. In particular, leakage caused by tilting the
plunger is to be avoided where possible. In addition, the
guiding of the plunger rod in the syringe body is to be
25 improved, in particular when using the syringe in a
syringe pump.

Said object is achieved by the subject matter with the
features according to the independent claims.
30 Advantageous embodiments are the object of the dependent
claims, the description and the drawings.

The prefilled syringe according to the invention includes
the following component parts: a syringe body which is
35 filled with a medical fluid and comprises on a front end
a nozzle, which is closed by way of a cap, and which is

closed on a rear end by way of a displaceable plunger, and a plunger rod which is insertable into the syringe body via the rear end and comprises on a front end a connecting portion, by means of which the plunger rod is connectable to the plunger, wherein at least three annular elements, which extend at least in portions about a longitudinal axis of the plunger rod, are arranged on the plunger rod on a rear end of the connecting portion such that when the plunger rod is fully connected to the plunger, they are situated in the syringe body. The syringe, in this case, is in its initial state. I.e. the plunger has not yet been moved to eject the fluid.

The three annular elements support a coaxial connection between the plunger rod and the plunger. The annular elements prove advantageous, on the one hand, as they prevent tilting over the entire circumference of 360°. On the other hand, the three annular elements make it possible for the user, when connecting the plunger rod to the plunger, to have haptic and/or acoustic control. If, for example, the user connects the plunger rod correctly to the plunger immediately, he does not receive a haptic and/or acoustic message. If, for example, in contrast, the user tries, unintentionally, to connect the plunger rod incorrectly askew, he is able to perceive, in particular, the transition of the plunger rod from the central annular element to the rear annular element on the edge of the rear syringe body opening as a type of jump, preferably connected to a type of click. As a result, the user is able to recognize that he is trying to connect the plunger rod incorrectly to the plunger and can then correct the position of the plunger rod in a corresponding manner.

The position of the plunger in the prefilled syringe body and the position of the three annular elements on the

plunger rod are matched to one another such that in a first step, when the plunger rod is placed by way of its connecting portion on the plunger, the two front rings are already arranged in the interior of the syringe body.

5 When connecting, for example screwing-in, the plunger rod is initially guided through the two front annular elements. The rear third ring supports the guiding of the plunger rod when the plunger rod is finally, fixedly connected to the plunger.

10

The three annular elements are positioned in the interior of the syringe body no later than in the state in which the plunger rod is fully connected to the plunger, preferably is screwed into the plunger.

15

According to a first embodiment, an outside diameter of the three annular elements is identical to an inside diameter of the syringe body or is somewhat smaller than an inside diameter of the syringe body. As a result, the
20 three annular elements can be guided on an inner side of the syringe body when connecting the plunger rod to the plunger and later when moving the plunger for ejecting the fluid. The outside diameter of the three annular elements is preferably identical.

25

In a further embodiment, wing elements or ribs, which extend radially outwardly, are arranged distributed over the circumference of the plunger rods, preferably individually, between the annular elements. The wing
30 elements preferably connect the annular elements together. The wing elements are proved to be advantageous as they enable guidance in a longer, in portions continuous manner along the longitudinal axis of the plunger rod.

35

In one design, at least four wing elements are arranged preferably at an angle of 90° with respect to one another, in particular individually, between the annular elements. Guidance that is as coaxial as possible is to be supported as a result. The wing elements preferably comprise an outside diameter which is identical to the inside diameter of the syringe body or is somewhat smaller than the inside diameter of the syringe body. In a first embodiment, the wing elements comprise a diameter which is identical to the outside diameter of the annular elements. The guidance of the plunger rod is improved even more as a result. In a second embodiment, the wing elements comprise an outside diameter which is smaller than an outside diameter of the annular elements. The haptic and/or acoustic control is improved as a result when the plunger rod is connected to the plunger and/or when the plunger rod is inserted into the syringe body. In one design, the outside diameter of the wing elements is reduced in relation to the outside diameter of the annular elements by between 1 mm and 10 mm, preferably by between 4 mm and 8 mm.

The prefilled syringe can be provided, for example, in an over pack. If, for example, the medical fluid is oxygen-sensitive and the syringe body is not sufficiently oxygen-impermeable, the syringe can be packaged in an oxygen-impermeable over pack, for example in a blister. The plunger rod can already be premounted, for example, on the plunger. However, it can also not be premounted and be located next to the syringe body in the over pack. Consequently, within the field of the invention is also an over pack having an interior in which the afore-described syringe according to the invention is enclosed.

In addition, within the field of the invention is also the plunger rod, in particular for a or for the

aforementioned prefilled syringe. The plunger rod includes a front-end connecting portion, by means of which the plunger rod is connectable to the plunger. In this case, at least three annular elements, which extend
5 at least in portions about a longitudinal axis of the plunger rod, are arranged on a rear end of the connecting portion. The three annular elements, preferably individually, are arranged at a distance R with respect to one another, where $0.5 \text{ mm} \leq R \leq 20 \text{ mm}$, in a preferred
10 manner $1 \text{ mm} \leq R \leq 10 \text{ mm}$ and particularly preferred $2 \text{ mm} \leq R \leq 8 \text{ mm}$. The annular elements have, for example, a thickness of approximately between 0.5 mm and approximately 5 mm , preferably between approximately 1 mm and approximately 3 mm . The plunger rod has a diameter D
15 where $8 \text{ mm} \leq D \leq 30 \text{ mm}$ and/or a length L where $80 \text{ mm} \leq L \leq 150 \text{ mm}$.

In addition, a syringe is also claimed, including a syringe body, a plunger and the afore-described plunger
20 rod, wherein the plunger is positionable in the syringe body in such a manner and the three annular elements are arranged on the plunger rod in such a manner that, when the plunger rod is fully connected to the plunger, they are situated in the syringe body. The syringe body is
25 preferably prefilled with a medical fluid.

The prefilled syringe can have, for example, a holding volume of between 5 ml and 100 ml . The medical fluid can be or include, for example, a fluid for enteral and/or
30 parenteral nutrition and/or for infusion. The medical fluid can be provided by a solution and/or by an emulsion. The medical fluid can also include medical substances. According to one embodiment, the medical fluid is or includes the medicinal fluid Propofol, in
35 particular a Propofol emulsion. Propofol is described by the chemical name 2,6-diisopropylphenol (IUPAC).

The syringe body can be molded from plastics material, which includes one of the following polymers: cyclo-olefin copolymer, cyclo-olefin polymer or crystal clear
5 polymer. Such a plastics material container is resistant to solvents. In particular, such a plastics material container can be used to store Propofol which acts as a solvent. The outer sides of the plunger and/or the inner side of the syringe body are preferably coated at least
10 in portions with a lubricant, preferably are siliconized.

According to one embodiment, the plastics material plunger rod is molded from plastics material which preferably includes one of the following polymers: cyclo-
15 olefin copolymer, cyclo-olefin polymer or crystal clear polymer, or it is molded from polypropylene.

The invention is described in detail below by way of exemplary embodiments in connection with the drawings, in
20 which:

fig. 1.a shows a side view of a plunger rod according to a first embodiment of the invention;

25 fig. 1.b shows a side view of a prefilled syringe according to the invention with the plunger rod from figure 1.a;

fig. 2.a shows a side view of a plunger rod according to
30 a second embodiment of the invention;

fig. 2.b shows a side view of a prefilled syringe according to the invention with the plunger rod from figure 2.a;

35

fig. 2.c shows a perspective view of the plunger rod according to the second embodiment of the invention from figure 2.a;

5 fig. 3 shows a perspective view of a plunger rod according to a third embodiment of the invention and

10 fig. 4 shows a perspective view of a plunger rod according to a fourth embodiment of the invention.

Fig. 1.a shows a plunger rod 15' according to a first embodiment of the invention. The plunger rod 15' has a substantially cross-shaped cross section and is formed by the two legs 3. Stabilizing elements 7 are mounted along the longitudinal axis. The rear end of the plunger rod 15' is closed off by a flange 4 with a larger diameter. The notches 5 provided on the rear end enable the plunger rod 15' (as a component part of the syringe 20) to be operated in a syringe pump. The plunger rod 15' is designed for operation in a syringe 20 with a holding volume of between approximately 50 ml and 70 ml. A graduation 6 to 50 ml is provided on the plunger rod 15'.
25 The plunger rod 15' has a diameter D where $25 \text{ mm} \leq D \leq 30 \text{ mm}$ and/or a length L where $100 \text{ mm} \leq L \leq 150 \text{ mm}$.

The front end of the plunger rod 15' is provided by a connecting portion 1, by means of which the plunger rod 15' is connected to a plunger 12, not shown here, (see figure 1.b in this respect). The connecting portion 1 is provided here, as an example, by a screw thread. Three annular elements 2a, 2b, 2c connect to the rear end of the connecting portion 1. As a result, when the plunger rod 15'' is screwed into the plunger 12, it is possible, in particular, for the user to have haptic and/or

acoustic control. The annular elements 2a, 2b, 2c preferably extend over the entire circumference of the plunger 15'. The front annular element 2a additionally forms the stop when the plunger rod 15' is screwed into the plunger 12. The three annular elements 2a, 2b, 2c are preferably arranged equidistantly with respect to one another. In one embodiment, the three annular elements 2a, 2b, 2c are arranged individually at a distance R of between 2 mm and 8 mm with respect to one another. The annular elements 2a, 2b, 2c have for example, a thickness of approximately between 0.5 mm and approximately 5 mm, preferably of approximately between 1 mm and approximately 3 mm.

The cross-shaped cross section of the plunger rod 15' is also continued between the three annular elements 2a, 2b, 2c. Ignoring the flange 4 and the connecting portion 1, the diameter D of the plunger rod is identical or substantially identical along the longitudinal axis. As a result, so-called wing elements 3a, 3b or ribs are formed between the three annular elements 2a, 2b, 2c. The front, here four, wing elements 3a connect the front ring 2a to the central ring 2b. The rear, here four, wing elements 3b connect the central ring 2b to the rear ring 2b. The annular elements 2a, 2b, 2c and the wing elements 3a, 3b enable the plunger rod 15' to be guided into the syringe body 8 in as coaxial a manner as possible and, as a result, enable the plunger rod 15' to be screwed into the plunger 12 in as coaxial a manner as possible (see figure 1.b in this respect). Placing the plunger rod 15' on the plunger 12 at an angle, leading to possible tilting of the plunger 12 and finally possibly to resultant leakage can be reduced or even avoided as a result.

Figure 1.b illustrates the use of the plunger rod 15' from figure 1.a in a prefilled syringe 20. The syringe 20

includes a syringe body 8 with a nozzle 9 arranged on the front end of the syringe body 8, a cap 11 closing the nozzle 9, a plunger 12 which is arranged in the syringe body 8 and closes the interior of the syringe body 8 in a fluid-tight manner, and the plunger rod 15' from figure 1a which is connected to the plunger 12 by means of its connecting portion 1. The connection between the plunger 12 and the plunger rod 15' is provided here by means of a screw connection. A thread, which is, however, not shown in the figure, is also provided in a corresponding manner in the interior of the plunger 12.

The outside diameter D or D_F of the plunger rod 15' and/or of the annular elements 2a, 2b, 2c and/or of the wing elements 3a, 3b can be identical to the inside diameter of the syringe body 8. In order to make it easier for the plunger rod 15' to move in the syringe body 8, the outside diameter D or D_F of the plunger rod 15' and/or of the annular elements 2a, 2b, 2c and/or of the wing elements 3a, 3b is, in particular, smaller than the inside diameter of the syringe body 8. The outside diameter D or D_F is preferably reduced in relation to the inside diameter of the syringe body 8 by approximately between 0.5 mm and 5 mm.

The prefilled syringe 20 can be filled, for example, via its initially open rear end and then can be closed by way of the plunger 12. The plunger rod 15' can then be connected to the plunger 12 at a later point in time, for example shortly before the application. However, the plunger 12 can also, for example, be inserted into the syringe body 8 with the plunger rod 15' already screwed into the plunger 12.

The position of the plunger 12 in the prefilled syringe body 8 and the position of the three annular elements 2a,

2b, 2c on the plunger rod 15' are preferably matched to one another in such a manner that in a first step, when the plunger rod 15' is placed on the plunger 12 by way of its connecting portion 1, the two front rings 2a, 2b are
5 already arranged in the interior of the syringe body 8 and are preferably guided by the inner side of the syringe body 8. When being screwed in, the plunger rod 15' is initially guided by the two front annular elements 2a, 2b and the front wing elements 3a and then also by
10 the rear wing elements 3b in the syringe body 8. The rear third ring 2c supports the guiding of the plunger rod 15' in the final, fixed connection between the plunger rod 15' and the plunger 12. The three rings 2a, 2b, 2c are positioned in the interior of the syringe body 8 no later
15 than in the state in which the plunger rod 15' is fully connected to the plunger 12, preferably is screwed into the plunger 12. The annular elements 2a, 2b, 2c prove to be advantageous as they prevent tilting over the entire circumference of 360°. The wing elements 3a, 3b prove to
20 be advantageous as they enable longer guidance along the longitudinal axis of the plunger rod 15'. The present invention joins said advantages together.

Figures 2.a to 2.c show a plunger rod 15'' according to a
25 second embodiment of the invention. Only the differences to the plunger rod 15' from figure 1.a are explained below. For all the other components, reference is made to the preceding description concerning figure 1.a. The plunger rod 15'' does not have a graduation. In contrast
30 to the embodiment shown in figure 1.a, the wing elements 3a, 3b, which connect the three annular elements 2a, 2b, 2c together, do not have the identical outside diameter as the three annular elements 2a, 2b, 2c. The outside diameter D_F of the wing elements 3a, 3b is smaller than
35 the outside diameter D of the three annular elements 2a, 2b, 2c. The outside diameter D_F of the wing elements 3a,

3b is preferably reduced by approximately between 4 mm and 8 mm in relation to the outside diameter D of the annular elements 2a, 2b, 2c. In the present case, there are precisely three annular elements which are located in
5 the front region of the plunger rod 15'.

As a result, when screwing the plunger rod 15'' into the plunger 12, it is possible, in particular, for the user to have haptic and/or acoustic control. If the user
10 screws the plunger rod 15'' correctly into the plunger 12 immediately, he does not receive a haptic and/or acoustic message. If, in contrast, the user tries, unintentionally, to screw the plunger rod 15'' into the plunger 12 incorrectly askew, he is able to perceive, in
15 particular, the transition of the plunger rod 15'' from the central annular element 2b to the rear annular element 2c on the edge 14 in the rear syringe body opening (see figure 2.b in this respect) as a type of jump, preferably connected to a type of click. As a
20 result, the user is able to recognize that he is trying to connect the plunger rod 15'' incorrectly to the plunger 12 and then he can correct the position of the plunger rod 15'' in a corresponding manner.

25 In addition, figure 3 shows a plunger rod 15''' according to a third embodiment of the invention. The design of said plunger rod 15''' corresponds substantially to the design of the plunger rod 15'' from figures 2.a to 2.c. The present plunger rod 15''' simply comprises different
30 dimensions as it is designed for a syringe 20 with a holding volume of between approximately 20 ml and 30 ml. The plunger rod 15''' has a diameter D where $13 \text{ mm} \leq D \leq 23 \text{ mm}$ and/or a length L where $100 \text{ mm} \leq L \leq 150 \text{ mm}$. The distance R between the annular elements here is also $2 \text{ mm} \leq R \leq 8 \text{ mm}$.
35

Finally, figure 4 shows a plunger rod 15'''' according to a fourth embodiment of the invention. The design of said plunger rod 15'''' corresponds substantially to the design of the plunger rods 15'' and 15''' from figures 2.a to 2.c and 3. The present plunger rod 15'''' simply comprises different dimensions as it is designed for a syringe 20 with a holding volume of between approximately 10 ml and 15 ml. The plunger rod 15'''' has a diameter D where $8 \text{ mm} \leq D \leq 18 \text{ mm}$ and/or a length L where $80 \text{ mm} \leq L \leq 110 \text{ mm}$. The distance R between the annular elements here is $2 \text{ mm} \leq R \leq 8 \text{ mm}$. In addition, no stabilizing elements 7 are provided on the plunger rod 15''''.

It is clear to the person skilled in the art that the described embodiments are to be understood as examples. The invention is not limited to said embodiments but can be varied in many different ways without departing from the essence of the invention. Features of individual embodiments and the features named in the general part of the description can be combined with one another both individually and together.

Claims

1. A prefilled syringe (20) including
- a syringe body (8) which is filled with a medical
5 fluid (10) and comprises on a front end a nozzle
(9), which is closed by way of a cap (11), and is
closed on a rear end by way of a displaceable
plunger (12), and
- a plunger rod (15', 15'', 15''', 15''''') which is
10 insertable into the syringe body (8) via the rear
end and comprises on a front end a connecting
portion (1), by means of which the plunger rod
(15', 15'', 15''', 15''''') is connectable to the
plunger (12), wherein
15 at least three annular elements (2a, 2b, 2c),
which extend at least in portions about a
longitudinal axis of the plunger rod (15', 15'',
15''', 15'''''), are arranged on the plunger rod
(15', 15'', 15''', 15''''') on a rear end of the
20 connecting portion (1) such that when the plunger
rod (15', 15'', 15''', 15''''') is fully connected
to the plunger (12), they are situated in the
syringe body.

25 2. The prefilled syringe (20) as claimed in the
preceding claim, characterized in that a position
of the plunger (12) in the prefilled syringe body
(8) and the position of the three annular elements
(2a, 2b, 2c) on the plunger rod (15', 15'', 15''',
30 15''''') are matched to one another such that in a
first step, when the plunger rod (15', 15'',
15''', 15''''') is placed by way of its connecting
portion (1) on the plunger (12), the two front
rings (2a, 2b) are arranged in the interior of the
35 syringe body (8).

3. The prefilled syringe (20) as claimed in one of
the preceding claims, characterized in that an
outside diameter (D) of the three annular elements

(2a, 2b, 2c) is identical to an inside diameter of the syringe body (8) or is somewhat smaller than an inside diameter of the syringe body (8).

- 5 4. The prefilled syringe (20) as claimed in one of the preceding claims, characterized in that the outside diameter (D) of the three annular elements (2a, 2b, 2c) is identical.
- 10 5. The prefilled syringe (20) as claimed in one of the preceding claims, characterized in that wing elements (3a, 3b), which extend radially outwardly and preferably connect the annular elements (2a, 2b, 2c) together, are arranged distributed over
15 the circumference of the plunger rod (15', 15'', 15''', 15''''), preferably individually, between the annular elements (2a, 2b, 2c).
- 20 6. The prefilled syringe (20) as claimed in one of the preceding claims, characterized in that at least four wing elements (3a, 3b) are arranged, preferably at an angle of 90° with respect to one another, in particular individually, between the
25 annular elements (2a, 2b, 2c).
- 30 7. The prefilled syringe (20) as claimed in one of the preceding claims, characterized in that the wing elements (3a, 3b) comprise an outside diameter (D_F) which is identical to the inside diameter of the syringe body (8) or is somewhat smaller than the inside diameter of the syringe body (8).
- 35 8. The prefilled syringe (20) as claimed in one of the preceding claims, characterized in that the wing elements (3a, 3b) comprise an outside diameter (D_F) which is identical to the outside diameter (D) of the annular elements (2a, 2b, 2c).

9. The prefilled syringe (20) as claimed in one of the preceding claims, characterized in that the wing elements (3a, 3b) comprise an outside diameter (D_F) which is smaller than an outside diameter (D) of the annular elements (2a, 2b, 2c).
10. The prefilled syringe (20) as claimed in one of the preceding claims, characterized in that the outside diameter (D_F) of the wing elements (3a, 3b) is reduced in relation to the outside diameter (D) of the annular elements (2a, 2b, 2c) by between 1 mm and 10 mm, preferably by between 4 mm and 8 mm.
11. The prefilled syringe (20) as claimed in one of the preceding claims, characterized in that the plunger rod (15', 15'', 15''', 15''') is premounted on the plunger (12).
12. The prefilled syringe (20) as claimed in one of the preceding claims, characterized in that the plunger rod (15', 15'', 15''', 15''') is located next to the syringe body (8) in a, preferably oxygen-impermeable, over pack.
13. An oxygen-impermeable over pack having an interior in which the syringe (20) as claimed in one of the preceding claims is hermetically enclosed.
14. A plunger rod (15', 15'', 15''', 15''') for a prefilled syringe (20) as claimed in one of the preceding claims, including a front-end connecting portion (1), by means of which the plunger rod (15', 15'', 15''', 15''') is connectable to a plunger (12), wherein at least three annular elements (2a, 2b, 2c), which extend at least in portions about a longitudinal axis of the plunger rod (15', 15'',

15''', 15''''') and which are arranged at a distance R where $0.5 \text{ mm} \leq R \leq 20 \text{ mm}$, preferably $1 \text{ mm} \leq R \leq 10 \text{ mm}$, are arranged on a rear end of the connecting portion (1).

5

15. A syringe (20) including a syringe body (8), a plunger (12) and a plunger rod (15', 15'', 15''', 15''''') as claimed in the preceding claim, wherein the plunger (12) is positionable in the syringe body (8) and the three annular elements (2a, 2b, 2c) are arranged on the plunger rod (15', 15'', 15''', 15''''') such that, when the plunger rod (15', 15'', 15''', 15''''') is fully connected to the plunger (12), they are situated in the syringe body (8), in particular wherein the syringe body (8) is prefilled with a medical fluid (10).
- 10
-
- 15

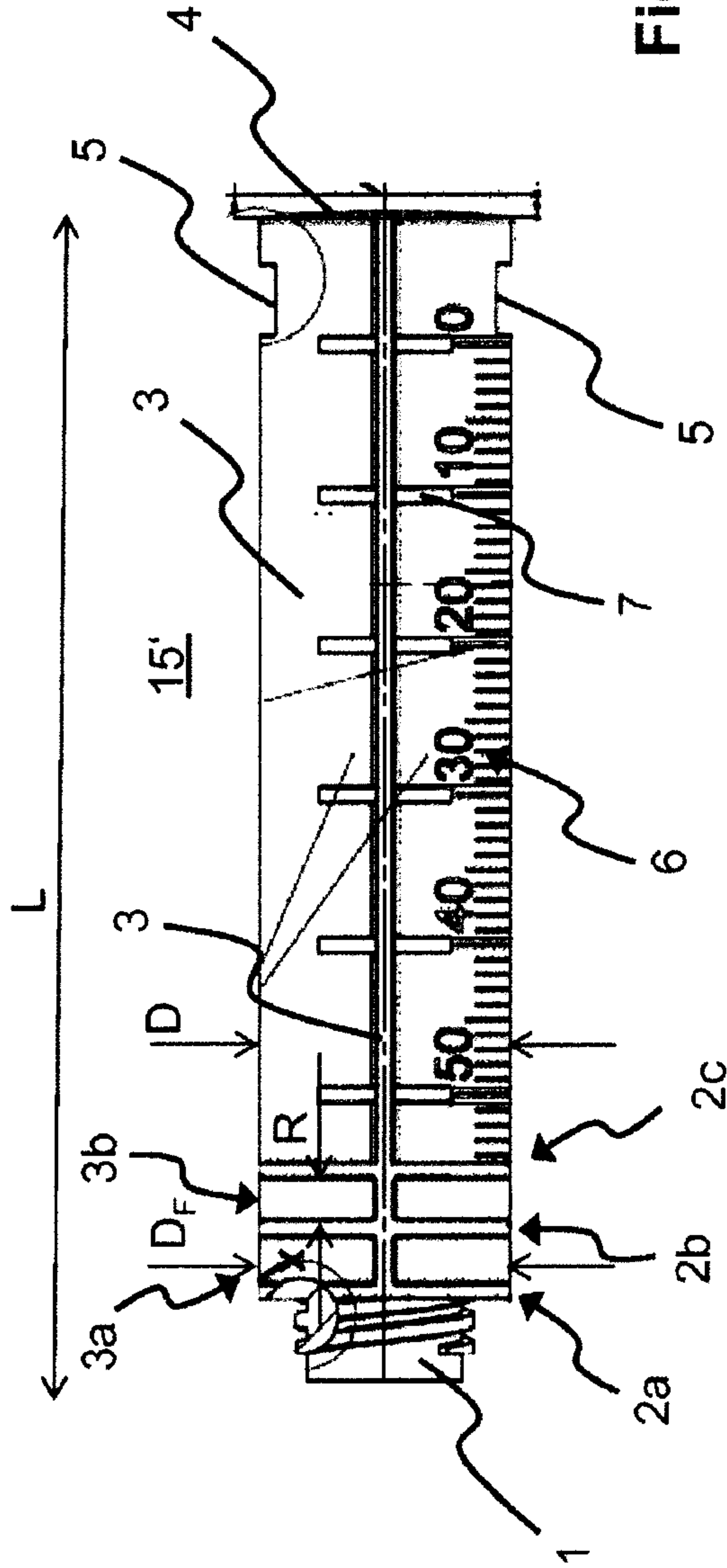

Fig. 1.a

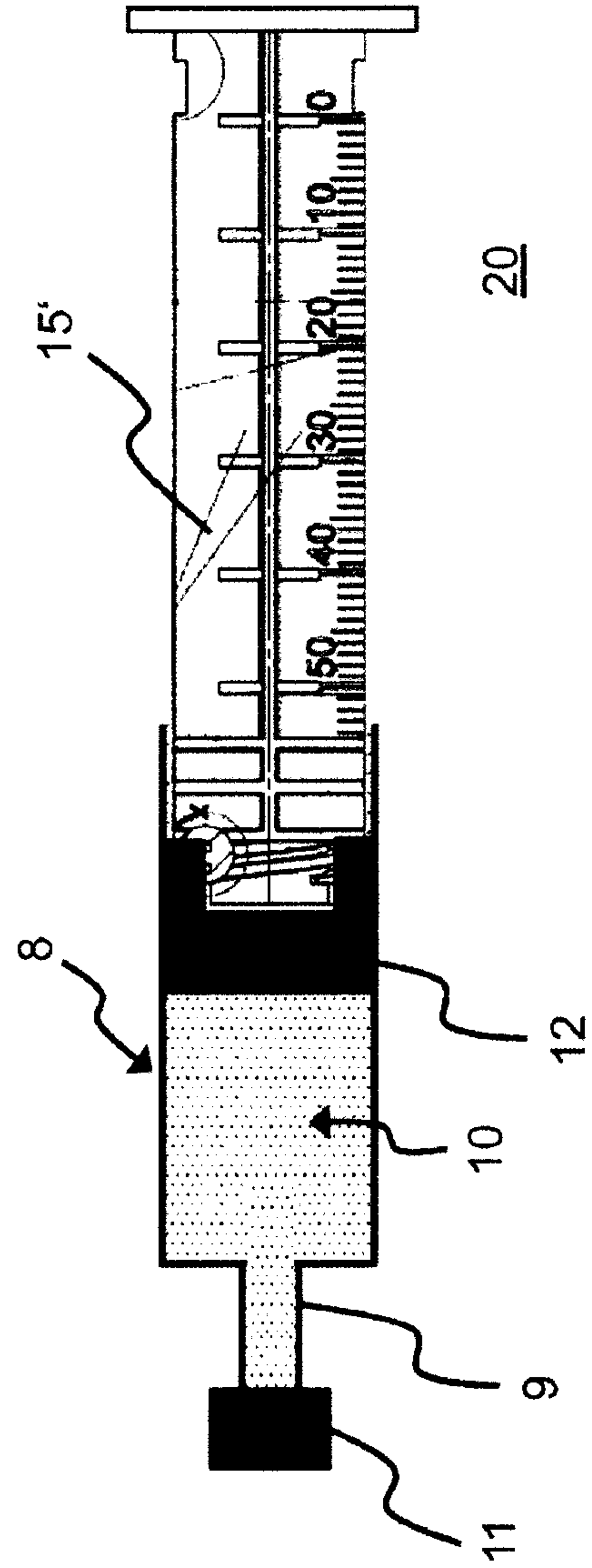

Fig. 1.b

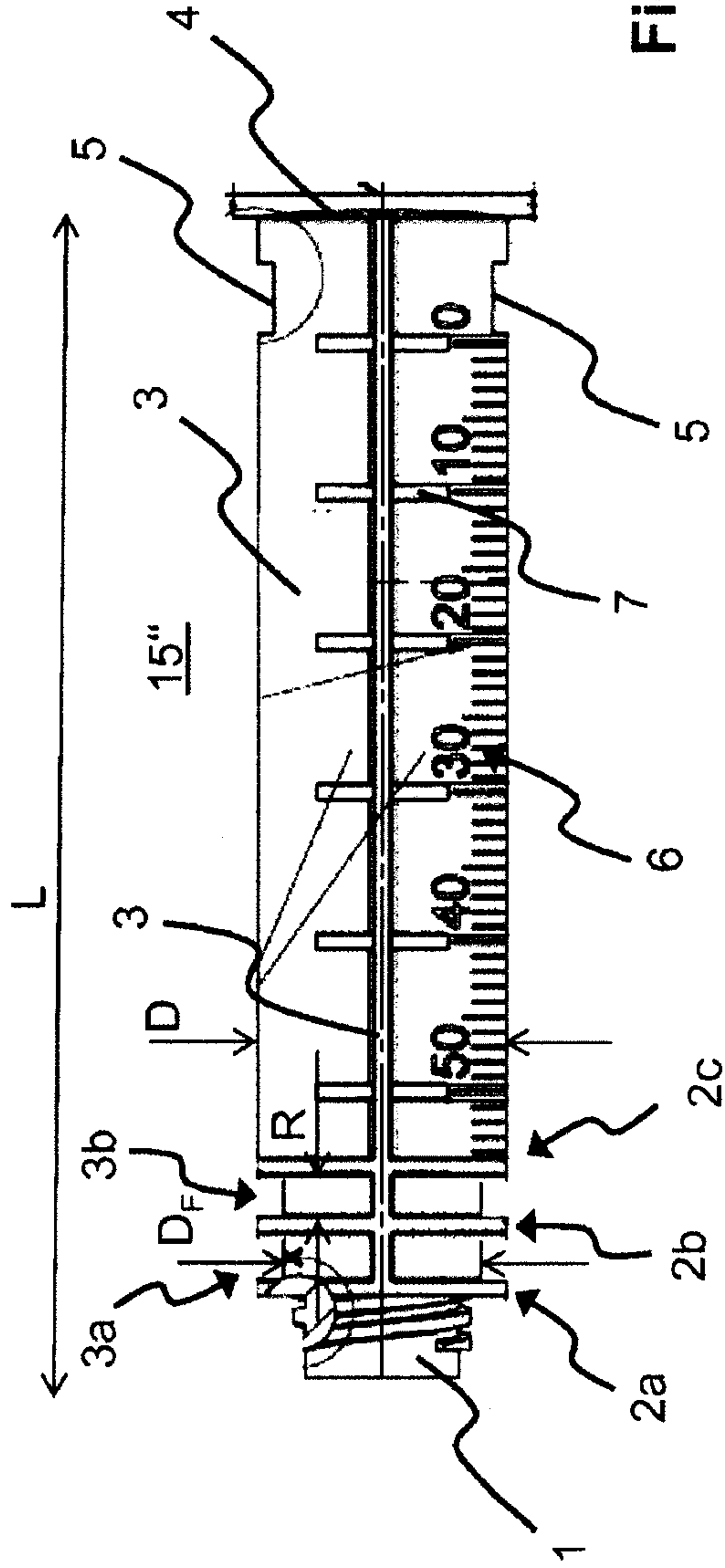

Fig. 2.a

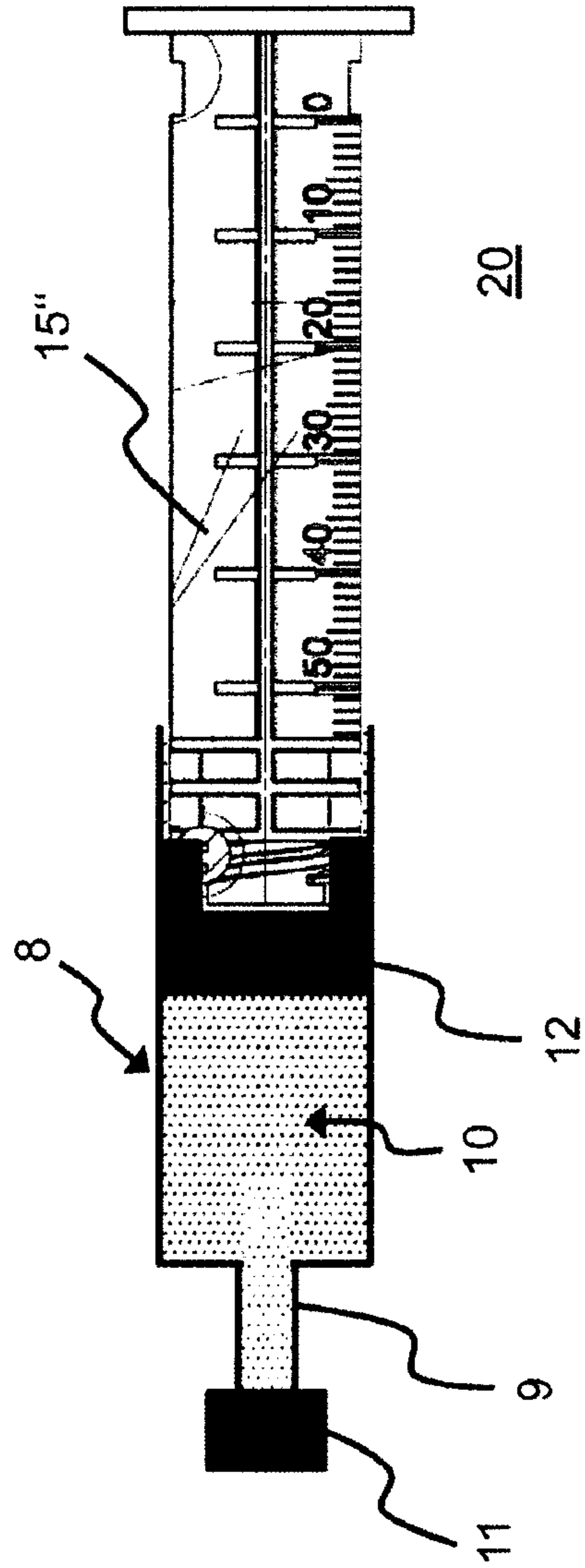

Fig. 2.b

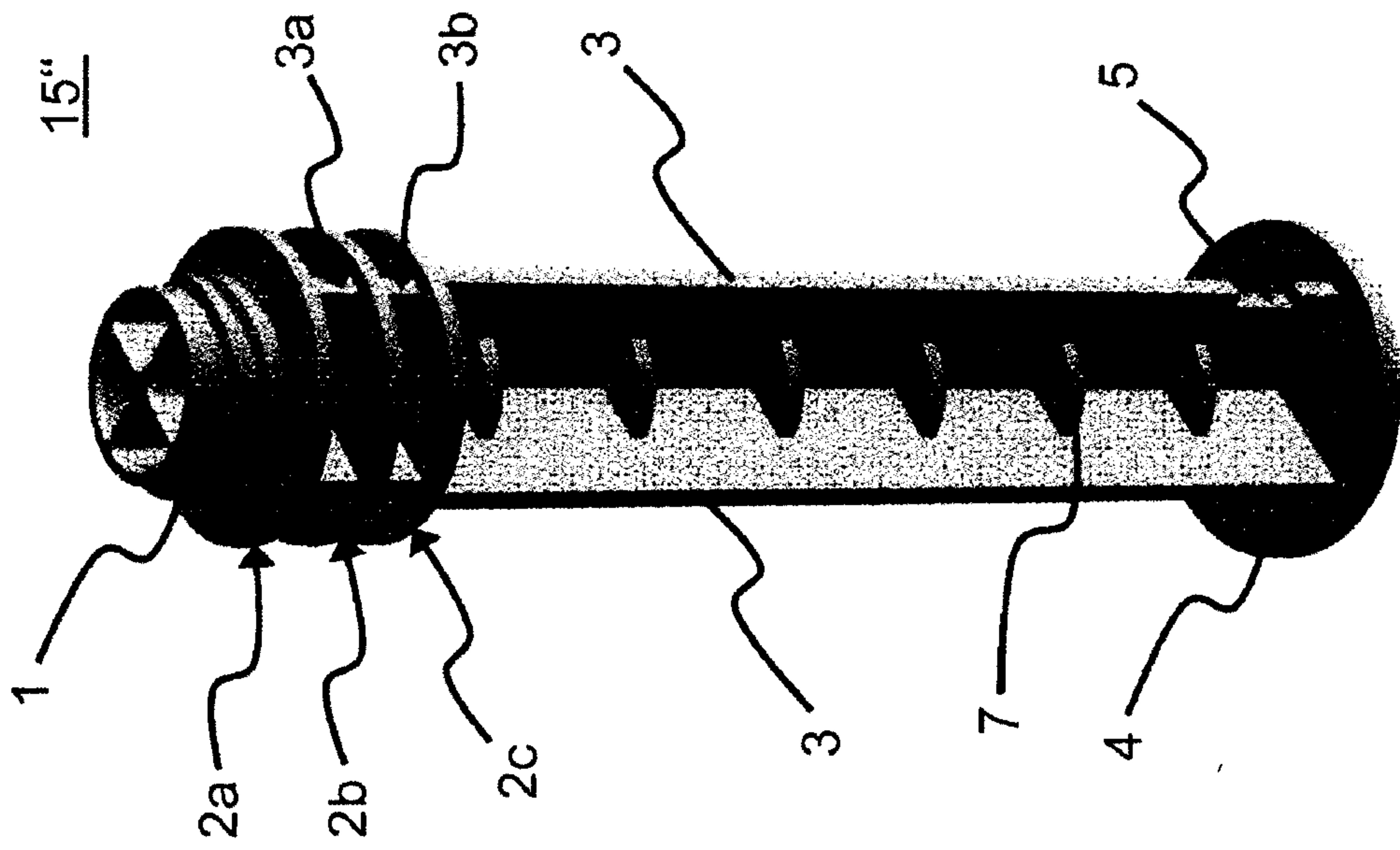

Fig. 2.c

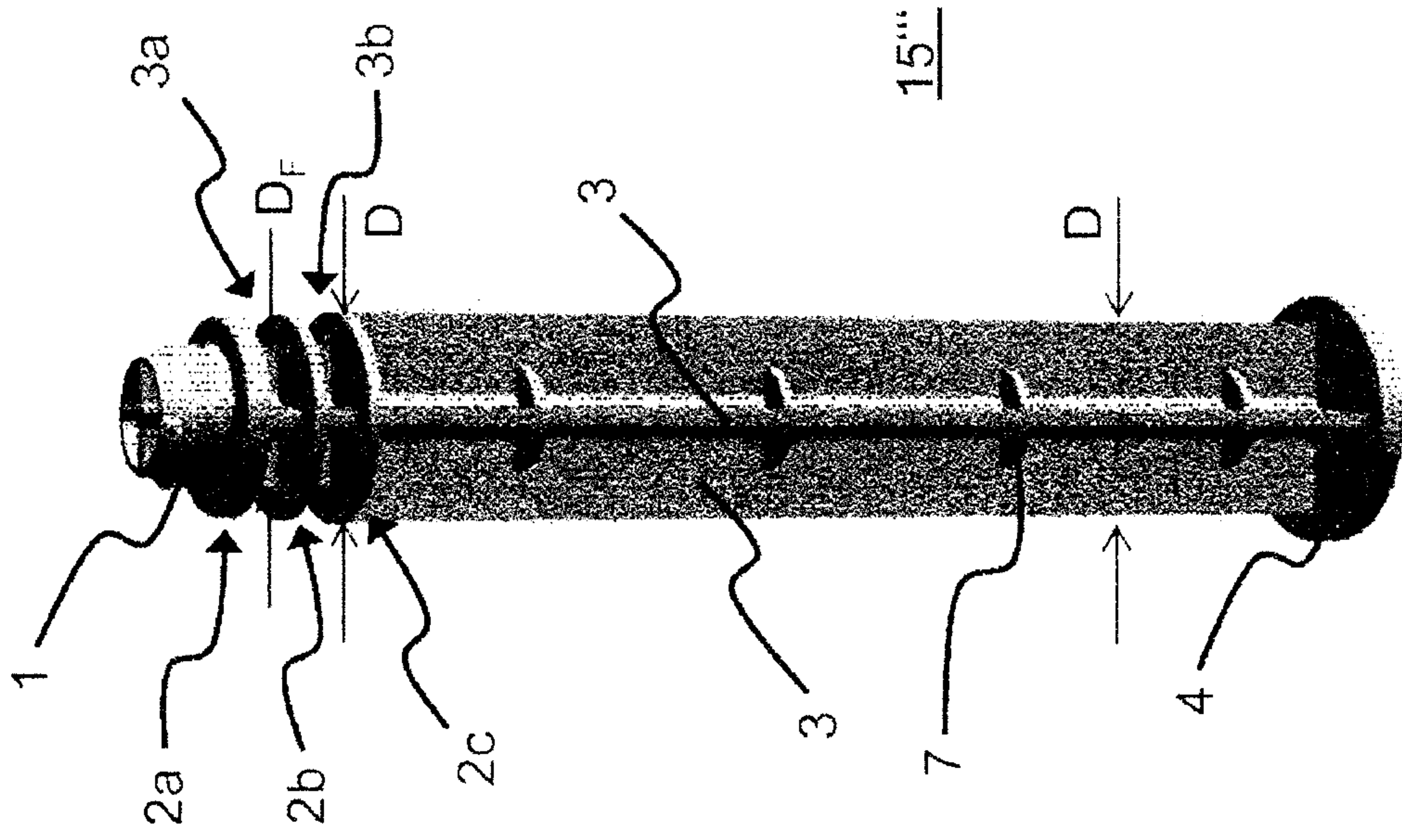

Fig. 3

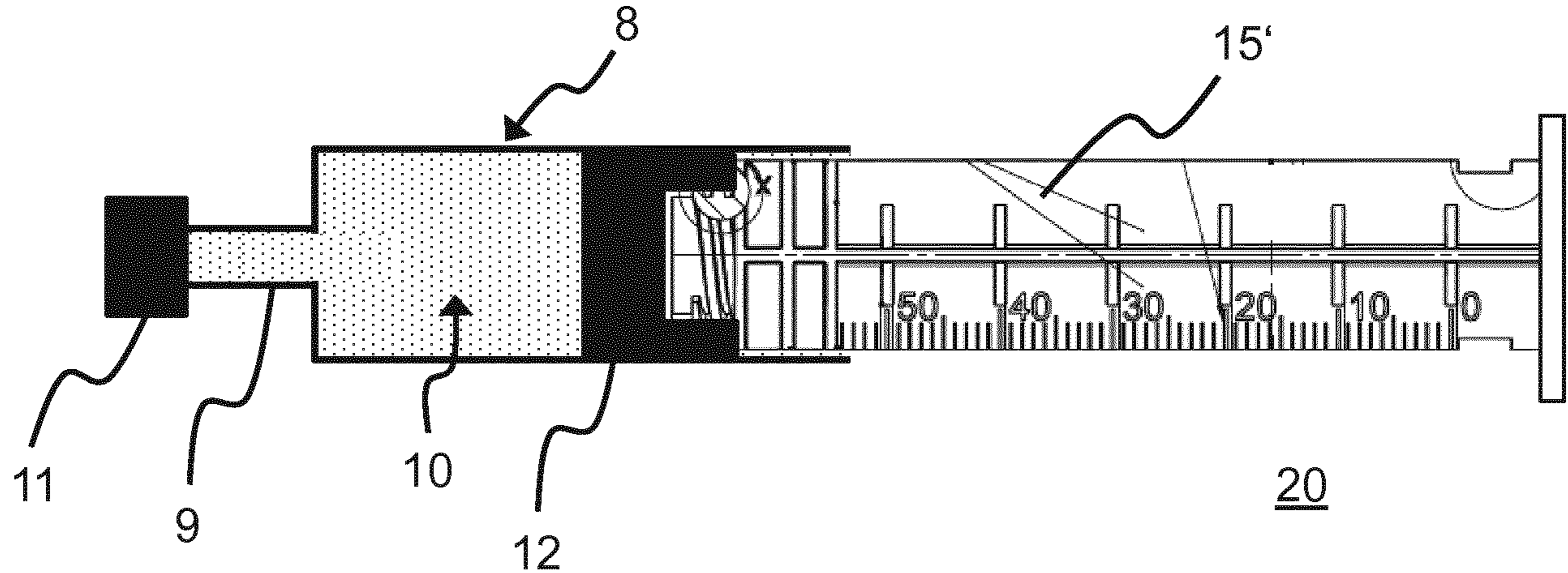

Fig. 1.b