

(19)



(11)

EP 2 482 965 B1

(12)

EUROPEAN PATENT SPECIFICATION

(45) Date of publication and mention of the grant of the patent:

25.04.2018 Bulletin 2018/17

(51) Int Cl.:

B01F 3/04 <small>(2006.01)</small>	A61L 2/18 <small>(2006.01)</small>
C02F 1/20 <small>(2006.01)</small>	C02F 1/78 <small>(2006.01)</small>
F24F 3/12 <small>(2006.01)</small>	B01F 5/04 <small>(2006.01)</small>

(21) Application number: **10819768.2**

(86) International application number:

PCT/CA2010/001520

(22) Date of filing: **30.09.2010**

(87) International publication number:

WO 2011/038489 (07.04.2011 Gazette 2011/14)

(54) **HOLDING TANK-LESS WATER OZONATING SYSTEM**

TANKLOSES WASSEROZONIERUNGSSYSTEM

SYSTÈME DE TRAITEMENT D'EAU À L'OZONE SANS CUVE DE RÉTENTION

(84) Designated Contracting States:

AL AT BE BG CH CY CZ DE DK EE ES FI FR GB GR HR HU IE IS IT LI LT LU LV MC MK MT NL NO PL PT RO SE SI SK SM TR

(72) Inventors:

- **HENGSPERGER, Steve, L.**
Tecumseh
Ontario N8N 1A8 (CA)
- **NAMESPETRA, Justin, L.**
Essex
Ontario N8M 1N3 (CA)

(30) Priority: **02.10.2009 US 248075 P**

02.10.2009 US 248055 P

02.10.2009 US 248102 P

(74) Representative: **HGF Limited**

**4th Floor
Merchant Exchange
17-19 Whitworth Street West
Manchester M1 5WG (GB)**

(43) Date of publication of application:

08.08.2012 Bulletin 2012/32

(60) Divisional application:

17192448.3

(56) References cited:

EP-A1- 1 859 675	WO-A1-2006/096990
WO-A1-2009/117141	US-A- 4 427 426
US-A1- 2002 060 189	US-A1- 2009 072 052

(73) Proprietor: **Tersano Inc.**

Oldcastle, Ontario N0R 1L0 (CA)

EP 2 482 965 B1

Note: Within nine months of the publication of the mention of the grant of the European patent in the European Patent Bulletin, any person may give notice to the European Patent Office of opposition to that patent, in accordance with the Implementing Regulations. Notice of opposition shall not be deemed to have been filed until the opposition fee has been paid. (Art. 99(1) European Patent Convention).

Description

FIELD OF THE INVENTION

[0001] The present application relates generally to devices, and related methods, that provide ozonated liquid. More particularly, the present application relates to tankless devices, and related methods, that provide ozonated liquid on demand.

BACKGROUND OF THE INVENTION

[0002] Ozone is a naturally occurring allotrope of oxygen. It has been known and used as an oxidant and disinfectant. In aqueous solutions, ozone is capable of killing bacteria in seconds at appropriate concentrations. It is often desirable to use ozone as a disinfecting or sanitizing agent as it imparts no odor and leaves no residue. The sanitizing properties of ozone dissolved in water, as well as its lack of odor and residue, make such a solution desirable to use for cleaning and disinfecting. Ozonated water can be used to disinfect or sanitize in both commercial and home settings. For example, ozonated water can be used to disinfect or sanitize bathroom counters, produce, dishes and cutlery, or floors.

[0003] One convenient method for using ozone as a disinfectant or sanitizer is to dissolve it in water or a water based solution. The stability of ozone is often a complicating factor in its use as a disinfecting or sanitizing agent since the high reactivity of ozone, which imparts its disinfecting and sanitizing properties, also results in reaction with reducing agents and, therefore, decomposition. In light of the poor stability of ozone, however, one difficulty is the delivery of ozonated water in an "on demand" basis. Ozone in ozonated water, produced in anticipation of demand, will eventually decompose and return to being non-ozonated water.

[0004] Known ozonation systems for producing ozonated water suitable for cleaning, disinfecting or sanitizing are designed with a tank of water and a recirculating ozonating flow path. The water flows through the ozonating flow path and dissolves an amount of ozone therein. Low efficiency in the ozonating flow path results in the need to recirculate the ozonated water back through the ozonation flow path in order to achieve the desired amount of dissolved ozone. This is typically achieved by recirculating the ozonated water back into the tank of water and running the ozonation system for a period of time until all the water in the tank is sufficiently ozonated.

[0005] Known ozonation systems have addressed the delay between (a) starting the system and (b) delivery of ozonated water having a usable level of ozone, by increasing the efficiency of the ozonating flow path and/or by using a continuously recirculating system.

[0006] It is possible to produce ozonated water "on demand" using a continuously recirculating system. Continuously recirculating systems have an ozonation flow path that recirculates ozonated water back to the holding

tank, and the system ozonates the water in the system regardless of whether ozonated water is being dispensed. In such systems, ozone is continuously added to the water to replace any ozone that has decomposed, or to ozonate any fresh water that has been added to replace ozonated water removed from the system. A steady-state of ozonated water is eventually reached based on the inlet and outlet flow rates, as well as the efficiency of the ozonation flow path. However, at the start of ozonation, the level of dissolved ozone is low and gradually increases until the steady-state is achieved.

[0007] There are a number of disadvantages with continuously recirculating systems. For example: they require energy to produce the constantly required ozone; ozone is corrosive with some materials; and there may be a fluctuation in the level of dissolved ozone if a significant amount of ozonated water is removed from the tank.

[0008] In traditional ozonation systems, both continuously and non-continuously recirculating systems, there is a delay between the start of the ozonation and the delivery of the ozonated water. A user must wait for the tank of water to be ozonated before the ozonated water can be used. In recirculating systems, starting the ozonation system and removing water from the tank before the ozonation is finished results in non-ozonated water or water with a low level of ozone dissolved therein. In continuously recirculating systems, a user must still wait for the level of ozonation in the water to increase to a usable level. During this time, the continuously recirculating system is either discharging water with low levels of ozone dissolved therein or not discharging water at all.

[0009] It is therefore desirable to provide an ozonation system that can dispense ozonated water "on demand" without the need for a continuously recirculating system, (i.e. an ozonation system that dispenses ozone via a single pass through the ozonating flow path) thereby doing away with the need for a holding tank.

[0010] Some ozonation systems use devices to separate, for example, water from undissolved ozone gas. Such devices are generally known as "off-gas" units, "degassing" units, or "gas-liquid" separators. All such devices take, as an input stream, a mixture of gas and liquid and provide, as separate output streams, a degassed liquid and a separated gas. The degassed liquid can have gas dissolved therein, even though bubbles of gas have been removed. Depending on the desired outlet stream, an off-gas unit can be used to produce, for example, a humidified gas stream, a gas-enriched liquid stream, or a completely degassed liquid.

[0011] Under conditions where the flow rate of a liquid is not crucial, the liquid can be degassed simply by letting the liquid and gas naturally separate due to differences in density between the liquid and gas. This process can be accelerated by placing the gas-liquid mixture under an external vacuum. In this situation, the reduced solubility of the gas is caused by the external vacuum, which encourages the gas to separate from the liquid in order to fill the vacuum.

[0012] Some known system use centrifugal separation to encourage the separation of gas from a gas-liquid mixture. In such systems, the degassing is achieved by the centrifugal forces on a liquid having a vortex flow. The centrifugal flow of liquid results in pressure differences in the liquid as a function of distance from the center axis of rotation. The low density gas and gas-liquid mixture are collected in the low pressure zone along the center of rotation, while the high density liquid is collected in the high pressure zone around the perimeter of rotation.

[0013] Increasing the flow rate in a given size of gas-liquid separator increases the centrifugal force in the vortex flow, resulting in a lower pressure in the low pressure zone and a higher pressure in the high pressure zone. This increase in centrifugal force hastens the separation of gas from the liquid. However, higher flow rates also lead to increased turbulence in the liquid flow as well as a lower residence time in the gas-liquid separator. This increased turbulence and lower residence time discourage separation of gas from liquid and lead to bubbles entering the degassed liquid output stream.

[0014] It is desirable to provide an off-gas unit that can separate a gas-liquid mixture into a degassed liquid and a separated gas at a high flow rate.

[0015] As discussed above, ozonated water can be used to sanitize items and surfaces, and is an effective replacement to chemical cleaners. Residential/consumer and commercial water ozonation systems are available to provide such functionality.

[0016] One example of a consumer water ozonation system is described in commonly assigned United States Patent Application Publication No. US-2008-0190825-A1. Such a system can include a removable filter cartridge. The removable filter cartridge facilitates better ozonation of water by way of a desiccant material provided therein to remove moisture, thereby achieving a higher concentration of ozone gas in the ozonated water.

[0017] Some cartridges and systems can include functionality to assist in determining when the cartridge should be replaced. For example, the cartridge in the '825 publication referred to above can have a "window" to assist in determining when the cartridge should be replaced, based on an observed colour of desiccant material. Other systems can provide an alarm or other indication when the cartridge reaches or approaches an end of life condition.

[0018] Another known ozonation system is described in the United States Patent No. US4427426, which describes an ozonizer for ozonizing air and a system for purifying water by means of ozonized air. Finally, a water treatment system using ozone in combination with hydrogen peroxide is known from International Publication Number WO 2009/117141 A1.

[0019] While different types of commercial ozonation systems or devices can both use cartridges, the cartridges used in each type of device are typically different from each other, and count usage in different ways, such as by cycles completed or by time used.

[0020] It is, therefore, desirable to provide a cartridge and ozonation system that enable use of the same cartridge in different types of ozonation devices.

5 SUMMARY OF THE INVENTION

[0021] It is an object of the present application to obviate or mitigate at least one disadvantage of previous ozonation systems. In one instance, a system for providing an ozonated liquid is described. The system comprises a liquid inlet and a liquid outlet. The liquid inlet is arranged to continuously accept a liquid into the system at a desired flow rate; the liquid outlet to dispense ozonated liquid out of the system, the ozonated liquid having an oxidation-reduction potential of at least 450 mV due solely to ozone dissolved in the liquid, the liquid outlet being in fluid communication with the liquid inlet and arranged to dispense the ozonated liquid out of the system at the desired flow rate. The system also comprises a tank-less ozonation flow path which is adapted to ozonate the accepted liquid, producing the ozonated liquid to be dispensed out of the system, the accepted liquid having a fluid residence time in the ozonation flow path of less than about 5 minutes prior to being dispensed as the ozonated liquid.

[0022] In an aspect, a system for providing an ozonated liquid is described. The system comprises a tank-less ozonation flow path having a liquid inlet and a liquid outlet. The liquid inlet is arranged to continuously accept a substantially unozonated liquid into the ozonation flow path at a desired flow rate; a liquid outlet to dispense ozonated liquid out of the system, the ozonated liquid optionally having an oxidation-reduction potential of at least 450 mV due solely to ozone dissolved in the liquid, the liquid outlet being in fluid communication with the liquid inlet and arranged to dispense the ozonated liquid out of the system at the desired flow rate. The tank-less ozonation flow path is adapted to ozonate the accepted liquid, producing the ozonated liquid to be dispensed out of the system, the accepted liquid having a fluid residence time in the ozonation flow path of less than about 5 minutes prior to being dispensed as the ozonated liquid.

[0023] In an embodiment, the liquid is accepted at an accepted pressure less than 758 kPa (110 psi) and the ozonated liquid is dispensed at a dispensing pressure which is directly dependent on the accepted pressure. The accepted pressure can be between about 138 kPa (20 psi) and about 689 kPa (100 psi), and the dispensing pressure can be between about 138 kPa (20 psi) and about 689 kPa (100 psi).

[0024] The ozonated liquid discharged from the system can have an oxidation-reduction potential of at least 650 millivolts. In an embodiment, the fluid residence time in the system can be less than 1 minute.

[0025] The ozonation flow path comprises a liquid-gas mixer, in fluid communication with the liquid inlet, to mix the accepted liquid with gaseous ozone to produce a gaseous liquid; and a gas-liquid separator, in fluid commu-

nication with the liquid-gas mixer, to separate the gaseous liquid into degassed ozonated liquid and separated gaseous ozone. The liquid-gas mixer can be a venturi for mixing the liquid with ozone gas. In an embodiment, the fluid residence time between the liquid-gas mixer and the gas-liquid separator is between about 0.01 and 0.1 seconds. Suitably, the liquid inlet of the ozonation flow path can be the liquid-gas mixer and the residence time of the ozonation flow path can be measured between the liquid-gas mixer and the liquid outlet.

[0026] The gas-liquid separator is for separating a gaseous liquid into a degassed ozonated liquid and a separated gaseous ozone, the gaseous liquid comprising bubbles of undissolved gaseous ozone and an ozonated liquid, the degassed liquid comprising dissolved ozone. The gas-liquid separator comprises a tubular member having a side wall, and top and bottom end walls, the tubular member having an upper portion and a lower portion; a gaseous liquid inlet for entry of the gaseous liquid, the inlet located in the lower portion of the tubular member and arranged to create a vortex of the gaseous liquid in the gas-liquid separator; a gas outlet located in the upper portion of the tubular member, the gas outlet arranged to vent the separated gas out of the gas-liquid separator; a liquid outlet for egress of the degassed liquid from the lower portion of the gas-liquid separator; and a separating annular baffle positioned in the lower portion of the tubular member and secured to the side wall of the tubular member.

[0027] In one particular description, a separating mixer can comprise an annular separating baffle concentric with the tubular member and can be arranged to direct the flow of the degassed liquid towards the liquid outlet and to direct the separated gas away from the liquid outlet, the separating baffle and the side wall defining an annular degassed liquid region therebetween; and an annular mixing baffle concentric with the annular separating baffle, the radius of the annular mixing baffle is smaller than the radius of the annular separating baffle.

[0028] In another description, the annular separating baffle and the annular mixing baffle can also be concentric and share a common center. The annular separating baffle can be positioned in line with the liquid outlet. Furthermore, the annular degassed liquid region can be open at both a top end and a bottom end, the degassed liquid flowable between the top end and the bottom end. The liquid outlet can also be for egress of the degassed liquid from the annular degassed liquid region.

[0029] The gaseous liquid inlet can be positioned substantially tangential to the side wall of the tubular member. The liquid outlet can be an annular aperture defined by the side wall or can be positioned substantially tangential to the side wall of the tubular member.

[0030] The gas-liquid separator of the present inventions comprises a tubular member having a side wall, and top and bottom end walls, the tubular member having an upper portion and a lower portion; a gaseous liquid inlet for entry of the gaseous liquid, the inlet located in

the lower portion of the tubular member and arranged to create a vortex of the gaseous liquid in the gas-liquid separator; a gas outlet located in the upper portion of the tubular member, the gas outlet arranged to vent the separated gas out of the gas-liquid separator; an annular separating baffle positioned in the lower portion of the tubular member and secured to the side wall of the tubular member, the annular separating baffle arranged to direct the flow of the degassed liquid towards the liquid outlet and to direct the separated gas away from the liquid outlet, the annular separating baffle and the side wall defining an annular degassed liquid region therebetween which is open at both top and bottom ends, the degassed liquid flowable between the top and bottom ends; and a liquid outlet for egress of the degassed liquid from the annular degassed liquid region.

[0031] In an embodiment, the annular separating baffle is positioned in line with the liquid outlet. In another embodiment, the gaseous liquid inlet is positioned substantially tangential to the side wall of the tubular member. In another embodiment, the liquid outlet is an annular aperture defined by the side wall. positioned substantially tangential to the side wall of the tubular member.

[0032] In one instance, a gas-liquid separator is described for separating a gaseous liquid into a degassed liquid and a separated gas, the gaseous liquid comprising bubbles of undissolved gas, the degassed liquid comprising dissolved gas.

[0033] The gas-liquid separator may comprise a tubular member having a side wall, and top and bottom end walls, the tubular member having an upper portion and a lower portion; a gaseous liquid inlet for entry of the gaseous liquid, the inlet located in the lower portion of the tubular member and arranged to create a vortex of the gaseous liquid in the gas-liquid separator; a gas outlet located in the upper portion of the tubular member, the gas outlet arranged to vent the separated gas out of the gas-liquid separator; a separating mixer positioned in the lower portion of the tubular member and secured to the side wall of the tubular member; and a liquid outlet for egress of the degassed liquid from the lower portion of the gas-liquid separator.

[0034] The separating mixer may comprise an annular separating baffle concentric with the tubular member and arranged to direct the flow of the degassed liquid towards the liquid outlet and to direct the separated gas away from the liquid outlet, the separating baffle and the side wall defining an annular degassed liquid region therebetween; and an annular mixing baffle concentric with the annular separating baffle, the radius of the annular mixing baffle is smaller than the radius of the annular separating baffle.

[0035] The annular separating baffle and the annular mixing baffle can share a common center. The annular separating baffle can be positioned in line with the liquid outlet. The annular degassed liquid region can be open at both a top end and a bottom end, with the degassed

liquid flowable between the top end and the bottom end. The annular degassed liquid region can be for egress of the degassed liquid from the annular degassed liquid region

[0036] The gaseous liquid inlet can be a tangential inlet. The liquid outlet can be an annular aperture defined by the side wall or a tangential outlet positioned in the side wall.

[0037] In another instance, the separator comprises a tubular member having a side wall, and top and bottom end walls, the tubular member having an upper portion and a lower portion; a gaseous liquid inlet for entry of the gaseous liquid, the inlet located in the lower portion of the tubular member and arranged to create a vortex of the gaseous liquid in the gas-liquid separator; a gas outlet located in the upper portion of the tubular member, the gas outlet arranged to vent the separated gas out of the gas-liquid separator; an annular separating baffle positioned in the lower portion of the tubular member and secured to the side wall of the tubular member, the annular separating baffle arranged to direct the flow of the degassed liquid towards the liquid outlet and to direct the separated gas away from the liquid outlet, the annular separating baffle and the side wall defining an annular degassed liquid region therebetween which is open at both top and bottom ends, the degassed liquid flowable between the top and bottom ends; and a liquid outlet for egress of the degassed liquid in the annular degassed liquid region.

[0038] The annular separating baffle can be positioned in line with the liquid outlet. The gaseous liquid inlet can be a tangential inlet. The liquid outlet can be an annular aperture defined by the side wall or a tangential outlet positioned in the side wall.

[0039] In another instance, a cartridge-enhanced water treatment system is described. The water treatment system includes a cartridge; a first ozonation device of a first type including a first device cycle count manager configured to signal the cartridge upon completion of an ozonation cycle of the first ozonation device with respect to a first ozonation device cycle count condition; and a second ozonation device of a second type, the second type different from the first type, the second ozonation device including a second device cycle count manager configured to signal the cartridge upon completion of an ozonation cycle of the second ozonation device with respect to a second ozonation device cycle count condition; the cartridge being arranged for integration and independent use with the first ozonation device and with the second ozonation device, and including: an air inlet to receive atmospheric air; a material to remove moisture and/or nitrogen from the received atmospheric air; an air outlet for interfacing with one of the first and second ozonation devices to provide dry and/or oxygen enriched air to an ozone generator; a usage counter arranged to modify a stored usage count in response to receipt of a signal from the first or second cycle count managers, and a device interface arranged to provide an expiry indication

indicating that the cartridge is no longer suitable for further use, based on the stored usage count.

[0040] The first and second cycle count managers can each comprise a cycle memory arranged to keep track of partially completed cycles.

[0041] The cartridge can include a cartridge compatibility identifier; and the first and second ozonation devices can include: first and second device compatibility identifiers, respectively, and first and second device compatibility managers can be arranged to determine whether the cartridge is compatible with the first or second ozonation device, respectively, based on a comparison of the cartridge compatibility identifier with the first and second device compatibility identifiers, respectively.

[0042] The first and second device compatibility managers can determine that the cartridge is compatible with the first or second ozonation device when the cartridge compatibility identifier is the same as the first or second ozonation device compatibility identifier, respectively.

[0043] The first and second device compatibility managers can determine that the cartridge is compatible with the first or second ozonation device when the first or second ozonation device compatibility identifier identifies a device class with which the cartridge compatibility identifier is compatible.

[0044] The cartridge can be compatible with a plurality of types of ozonation device of the identified device class. The usage counter can be reset in response to receipt of a usage counter reset signal.

[0045] The system can further include a usage counter reset manager, in communication with the cartridge, arranged to send a usage counter reset signal to reset the usage counter in the cartridge. The usage counter reset manager can be arranged to determine an expected life of a dried desiccant material prior to sending the usage counter reset signal. The usage counter reset manager can be arranged to provide a modified value with which the usage counter can be reset, the modified value being based on measured properties of the desiccant material.

[0046] The cartridge can be a desiccant cartridge that includes a material to remove moisture from the received atmospheric air.

[0047] The first ozonation device of a first type can be a water ozonation system that includes a liquid inlet arranged to continuously accept a liquid into the system at a desired flow rate; a liquid outlet to dispense ozonated liquid out of the system, the ozonated liquid having an oxidation-reduction potential of at least 450 mV due solely to ozone dissolved in the liquid, the liquid outlet being in fluid communication with the liquid inlet and arranged to dispense the ozonated liquid out of the system at the desired flow rate; a tank-less ozonation flow path between the liquid inlet and the liquid outlet, the flow path adapted to ozonate the accepted liquid, producing the ozonated liquid to be dispensed out of the system, the accepted liquid having a fluid residence time in the ozonation flow path of less than 5 minutes prior to dispensing as the ozonated liquid; an ozone generator having an air

inlet for interfacing with the air outlet of the cartridge and arranged to provide generated ozone to the ozonation flow path. The second ozonation device of a second type can be a water ozonation system that includes a reservoir for containing and dispensing a liquid; an ozone generator having an air inlet for interfacing with the air outlet of the cartridge and arranged to provide generated ozone to a liquid-gas mixer for increasing the level of oxidative properties in said liquid; a circulation flow path communicating with said reservoir and said liquid-gas mixer to allow at least some of said liquid in said reservoir to flow from said reservoir to said liquid-gas mixer and back to said reservoir.

[0048] In another instance, a cartridge, arranged for integration and use with first and second ozonation devices of different types, is described. The cartridge includes an air inlet to receive atmospheric air; a material to remove moisture and/or nitrogen from the received atmospheric air; an air outlet for interfacing with one of the first and second ozonation devices to provide dry and/or oxygen enriched air to an ozone generator; a usage counter arranged to modify a stored usage count in response to receipt of a first cycle completion signal received from the first ozonation device representing completion of an ozonation cycle with respect to a first ozonation device cycle count condition, and to modify the stored usage count in response to receipt of a second cycle completion signal received from the second ozonation device representing completion of an ozonation cycle with respect to a second ozonation device cycle count condition; a device interface arranged to provide an expiry indication indicating that the cartridge is no longer suitable for further use based on the stored usage count.

[0049] In a further instance, a method of removing moisture from atmospheric air using a cartridge described above is detailed. The method includes receiving the atmospheric air from the air inlet; contacting the desiccant material with the received atmospheric air; providing dry air to an ozone generator through the dry air outlet; modifying the stored usage count in response to: (a) the first cycle completion signal received from the first ozonation device representing completion of an ozonation cycle with respect to a first ozonation device cycle count condition, or (b) the second cycle completion signal received from the second ozonation device representing completion of an ozonation cycle with respect to a second ozonation device cycle count condition; providing an expiry indication when the cartridge is no longer suitable for further use based on the stored usage count.

[0050] The first and second cycle count managers can each comprise a cycle memory, and the method further can include keeping track of partially completed cycles using the cycle memory.

[0051] The method can further include resetting the usage counter in response to receipt of a usage counter reset signal.

[0052] The method can further include sending the us-

age counter reset signal by a usage counter reset manager in communication with the cartridge.

[0053] The method can further include determining, at the usage counter reset manager, an expected life of a dried desiccant material prior to sending the usage counter reset signal.

[0054] The method can further include providing a modified value with which the usage counter can be reset, the modified value being based on measured properties of the desiccant material and being provided by the usage counter reset manager

[0055] Features of the present invention will become apparent to those ordinarily skilled in the art upon review of the following description of specific examples of the invention in conjunction with the accompanying figures.

BRIEF DESCRIPTION OF THE DRAWINGS

[0056] Features of the present application will now be described, by way of example only, with reference to the attached Figures, wherein:

Fig. 1 is a schematic of a holding tank-less ozonation system according to one embodiment of the present application;

Fig. 2 is an cross-sectional view of a known gas-liquid separator;

Fig. 3 is an exploded cross-sectional view of a gas-liquid separator usable in a holding tank-less ozonation system;

Fig. 4 is a view taken along line 4-4 of Figure 3;

Fig. 5 is a close-up, cross-sectional view of another embodiment of a gas-liquid separator usable in a holding tank-less ozonation system according to one embodiment of the present application;

Fig. 6 is a cross-sectional view of a floor scrubber fitted with a holding tank-less ozonation system;

Fig. 7 is a block diagram of a cartridge-enhanced water treatment system including a first ozonation device, a second ozonation device, and a cartridge arranged to interface with the first and second ozonation devices.

Fig. 8A is a top front right perspective view of a cartridge.

Fig. 8B is an exploded, top front right, perspective view of a cartridge.

Fig. 9 is a mechanical system diagram of an exemplary water ozonation system with which a cartridge can be used.

Fig. 10 is a back perspective view of a removable cartridge installed in a base unit of a water ozonation device.

DETAILED DESCRIPTION

[0057] Generally, the present application provides a system for generating ozonated liquid. While the following description describes the ozonation of water, it is ap-

preciated that the principles of the application, which are demonstrated by the following embodiments, can be equally applied to the ozonation of other liquids (for example: organic solvents, oils, mixtures of water and additives). It is appreciated that additives can affect the oxidation-reduction potential of ozonated water and/or the stability of the ozonated water. It may, therefore, be desirable to include such additives when producing ozonated water. Suitable additives include, for example, acetic acid. Additionally, while the following description describes the separation of ozone from water, it is to be understood that the principles described herein, which are described in relation to particular examples, may equally be applied to the separation of other gases (for example: oxygen, nitrogen, hydrogen, chlorine, fluorine) from other liquids (for example: organic solvents, oils).

[0058] The present application describes a system which provides an ozonated liquid. In one instance, the system can comprise a liquid inlet arranged to continuously accept a liquid into the system at a desired flow rate; a liquid outlet to dispense ozonated liquid out of the system, the ozonated liquid having an oxidation-reduction potential of at least 450 mV due solely to ozone dissolved in the liquid, the liquid outlet being in fluid communication with the liquid inlet and arranged to dispense the ozonated liquid out of the system at the desired flow rate. This system has a tank-less ozonation flow path between the liquid inlet and the liquid outlet, the flow path being adapted to ozonate the accepted liquid, producing the ozonated liquid to be dispensed out of the system. The accepted liquid has a fluid residence time in the ozonation flow path of less than 5 minutes prior to being dispensed as the ozonated liquid.

[0059] In an aspect, the system comprises a tank-less ozonation flow path having a liquid inlet and a liquid outlet, the liquid inlet arranged to continuously accept a substantially unozonated liquid into the ozonation flow path at a desired flow rate; the liquid outlet to dispense ozonated liquid out of the system, the ozonated liquid optionally having an oxidation-reduction potential of at least 450 mV due solely to ozone dissolved in the liquid, the liquid outlet being in fluid communication with the liquid inlet and arranged to dispense the ozonated liquid out of the system at the desired flow rate. The tank-less ozonation flow path is adapted to ozonate the accepted liquid, producing the ozonated liquid to be dispensed out of the system. The accepted liquid has a fluid residence time in the ozonation flow path of less than 5 minutes prior to being dispensed as the ozonated liquid.

[0060] Embodiments of the present application are non-recirculating systems having a holding tank-less ozonation flow path with a liquid inlet and liquid outlet. Such tank-less, non-recirculating systems accept liquid so long as liquid is being dispensed from the system, and dispense liquid so long as the system is accepting liquid. Liquid is only dispensed when more accepted liquid enters the system. In order to dispense ozonated liquid, the accepting, dispensing and ozonating must all occur at

the same time.

[0061] One particular example of a system according to the present application is illustrated as element **10** in Figure **1**. The liquid inlet **12** is arranged to accept water to be ozonated into the system. In the illustrated example, the liquid inlet **12** accepting water into the system accepts liquid directly into the ozonation flow path. However, it is to be understood that it is not necessary for the liquid inlet **12** to accept liquid into the ozonation system and that the ozonation flow path can accept liquid which has already been accepted by the ozonation system. The liquid inlet **12** continuously accepts the water as long as ozonated water is being produced. Water flows at a desired flow rate into venturi **14**. Ozone gas provided by an ozone generator **16** is mixed with the water in venturi **14**.

[0062] The ozone-water mixture flows into gas-liquid separator **18**, which separates the gas-liquid mixture into degassed ozonated water and separated ozone gas. The separated ozone gas is destroyed in ozone destructor **20** and oxygen gas is vented to the atmosphere. Degassed ozonated water is provided to liquid outlet **22** by the gas-liquid separator **18**. Liquid outlet **22** dispenses ozonated liquid at the desired flow rate (e.g. for use by an end user). The flow rate out of the liquid outlet **22** is the same as the flow into the liquid inlet **12** since the flow in is directly dependent on the flow out and any liquid accepted by the system must displace liquid within the system. It is appreciated that in a system having a tank, the flow in is not directly dependent on the flow out and liquid could be dispensed from the tank even if no liquid was flowing into the system.

[0063] In the context of the present application, "directly dependent on" is to be understood to mean that the ozonation flow path is connected such that changes to the accepted pressure result in changes to the dispensing pressure and, similarly, that changes to the inlet flow rate result in changes to the dispensing flow rate. Changes to the accepted pressure result in changes to the dispensing pressure since the contemplated systems do not include any pressure regulating systems. For example, if the accepted pressure is initially 552 kPa (80 psi) and the dispensing pressure is 414 kPa (60 psi), and the accepted pressure was dropped to 414 kPa (60 psi), the dispensing pressure would drop to 276 kPa (40 psi) since the dispensing pressure is directly dependent on the accepted pressure. Likewise, changes to the inlet flow rate result in changes to the dispensing flow rate since there is no holding tank and accepted liquid displaces liquid already in the system, resulting in dispensed liquid.

[0064] Ozonation systems according to embodiments of the present application can also have the dispensing pressure be substantially equal to accepted pressure. Substantially equal pressure is to be understood to mean that the dispensing pressure is about 414 kPa (60 psi) less than the accepted pressure, and in particular embodiments is about 276 kPa (40 psi), about 207 kPa (30 psi), about 138 kPa (20 psi) or about 69 kPa (10 psi) less than the accepted pressure.

[0065] Ozonation systems according to embodiments of the present application can also have the dispensing flow rate be substantially equal to the accepted flow rate. In particular embodiments of the ozonation system according to the present application, the system can have a dosing system to add an additive to the accepted liquid, resulting in an dispensing flow rate that is larger than the accepted flow rate. In particular embodiments of the ozonation system according to the present application, the system can have a leak or other liquid outlet in advance of the dispensing liquid outlet, resulting in an dispensing flow rate that is less than the accepted flow rate. Substantially equal flow rate is to be understood to mean that the dispensing flow rate is between about 80% and 120% of the accepted flow rate, and in particular embodiments is between about 90% and about 110%, about 95% and about 105%, or about 99% and about 101% of the accepted flow rate.

[0066] Liquid-Gas Mixer. Ozonation systems according to embodiments of the present application have a liquid-gas mixer for mixing the ozone and the liquid. In the system illustrated in Figure 1, the liquid-gas mixer is venturi **14**. As described above, the liquid-gas mixer **14** is in fluid communication with the liquid inlet **12** and is arranged to dissolve ozone gas in the liquid to produce the ozonated liquid. Liquid-gas mixers are well known in the art, and include such mixers as venturi mixers. Briefly, a venturi mixer is a tube with a constricted flow path, which causes an increase in flow velocity and a corresponding decrease in pressure. The decrease in pressure results in a pressure differential, which draws gas into the liquid.

[0067] Gas-liquid separator. Systems also have a gas-liquid separator in fluid communication with both the liquid gas-mixer and the liquid outlet. The gas-liquid separator, shown as element **18** in the example illustrated in Figure 1, can be arranged to separate undissolved ozone gas from the ozonated liquid.

[0068] In particular embodiments, the ozonation system according to the present invention includes a gas-liquid separator which can separate ozone from water at high flow rates. Suitably, the gas-liquid separator can comprise a tubular member; a gaseous liquid inlet for entry of the gaseous liquid, the inlet arranged to create a vortex of the gaseous liquid in the gas-liquid separator; a gas outlet arranged to vent the separated gas out of the gas-liquid separator; a separating mixer secured to the tubular member; and a liquid outlet for egress of the degassed liquid from the annular degassed liquid region.

[0069] The separating mixer can comprise an annular separating baffle concentric with the tubular member and arranged to direct the flow of the degassed liquid towards the liquid outlet and to direct the separated gas away from the liquid outlet, the separating baffle and the side wall of the tubular member defining an annular degassed liquid region therebetween. The separating mixer can further comprise an annular mixing baffle concentric with the annular separating baffle, the radius of the annular

mixing baffle being smaller than the radius of the annular separating baffle.

[0070] Previously known gas-liquid separators are illustrated in Figure 2 and include gas-liquid inlet **10** for inducing vortex flow **112**. The gaseous liquid injected via inlet **110** separates into separated gas and degassed liquid. The separated gas coalesces into bubbles **114** and is vented out of the gas-liquid separator via gas outlet **116**. The degassed liquid is dispensed from the gas-liquid separator via degassed liquid outlet **118**.

[0071] Figure 3 illustrates one example of a gas-liquid separator as described herein. In use, gaseous liquid enters a tangentially positioned gas-liquid inlet **110**, which is positioned in a lower portion **120** of tubular interior chamber **122**. The gas-liquid inlet **110** induces a vortex flow **112** of gaseous liquid. The gaseous liquid is injected at a flow rate sufficient to induce a vortex flow **112** of the gaseous liquid within the interior chamber **122**. Such a vortex flow **112** has a center of rotation and a low-pressure zone located at the center of rotation. The vortex flow **112** has a high-pressure zone around the periphery of the vortex flow **112**, for example where the liquid contacts the tubular interior chamber **122**.

[0072] The vortex flow **112** of liquid first encounters mixing baffle **124**, which creates turbulence in the vortex flow **112** of gaseous liquid, thereby breaking up bubbles and increasing the total surface area of the bubbles. This increase in surface area can enhance the dissolution of the gas into the liquid. A mixer, therefore, should be understood to be a turbulence enhancer which increases the amount of dissolved gas in the degassed liquid. Mixing baffle **124** defines a plurality of apertures **126** for fluid communication between the inner and outer regions defined by the mixing baffle **124**. The apertures **126** are illustrated as slots extending axially along the central longitudinal axis. The slots can be evenly spaced around the baffle and equally spaced from each other.

[0073] In an example of a gas-liquid separator, a mixer can also act to direct bubbles of separated ozone gas in to the upper portion of the tubular interior chamber, thereby ensuring that the bubbles are directed to the gas outlet.

[0074] It is to be understood that, in a vortex flow, the pressure on a fluid element is a function of the centrifugal force exerted on that fluid element, which is a function of the velocity and the distance from the central longitudinal axis. The pressure is, therefore, lowest along the center of rotation (where the centrifugal force is smallest) and the pressure is greatest along the periphery of the vortex (where the centrifugal force is largest). The low pressure zone expedites bubbles of undissolved gas coalescing together. Gas separates from the liquid due to the vortex flow **112**, coalesces and rises towards the upper portion **128** of the tubular interior chamber **122**. The vortex flow **112** of gaseous liquid eventually becomes a vortex flow of degassed liquid as the degassed liquid separates from the separated gas.

[0075] The vortex flow **112** of liquid next encounters separating baffle **130**, which is positioned in line with de-

gassed liquid outlet **132**. It is desirable to prevent bubbles of gas from exiting the gas-liquid separator through the degassed liquid outlet **132**. In a situation of vortex flow, where the degassed liquid outlet **132** is positioned in the high-pressure zone at the periphery of the vortex flow **112**, bubbles of gas can be swept into the degassed liquid outlet **132** before they coalesce in the low pressure zone. In order to direct bubbles of gas away from the degassed liquid outlet **132**, devices as described herein have a separating baffle **130** positioned in line with the degassed liquid outlet **132**. Separating baffle **130** can be positioned to create a thin slit between the side wall and baffle, the thin slit for directing the degassed liquid to the degassed liquid outlet **132** and for trapping bubbles of gas that have not coalesced in the upper portion **128** of the tubular interior chamber **122**. Suitably, the separating baffle can be co-axial to the degassed liquid outlet **132**.

[0076] Degassed liquid outlet **132** is positioned at the periphery of the vortex, in the high-pressure zone, in order to provide egress for liquid which has been degassed. The separating baffle **130** directs separated gas away from the degassed liquid outlet **132** and degassed liquid towards degassed liquid outlet **132**. The combination of mixing baffle **124** and separating baffle **130** are one example of separating mixer **134**. It is to be understood that a separating mixer enhances the turbulence in a fluid, increasing the amount of dissolved gas in the degassed liquid, and directs separated gas away from the liquid outlet while directing the degassed liquid towards the liquid outlet.

[0077] The degassed liquid outlet **132** is positioned above the gas-liquid inlet **110** and below gas outlet (not shown). The liquid outlet **132** accepts the degassed fluid from the high-pressure zone and allows the degassed fluid to flow out of the interior chamber **122**. The degassed liquid outlet **132** is understood to be properly positioned when it is sufficiently far away from both the gaseous liquid inlet **110** and the gas outlet that neither the gaseous liquid nor the separated gas exits via the degassed liquid outlet during conditions of vortex flow. It can also be desirable to position the degassed liquid outlet **132** close to the gaseous liquid inlet **110** and the gas outlet so that the gas-liquid separator does not become overly large. In this manner, the gas-liquid separator can be as small as possible without compromising the effectiveness of the gas-liquid separator.

[0078] The separating baffle **130** and side wall of the interior chamber **122** define a degassed liquid region **136** therebetween. The separating baffle **130** is spaced apart from the side wall. The degassed liquid region **136** is open at the top and bottom ends, and liquid can flow through the degassed liquid region **136** between the top and bottom ends. Figure **3** illustrates the liquid outlet **132** as an annular aperture defined by side walls of the interior chamber **122**. The liquid outlet **132** leads to collecting outlet **138**, which provides a flow of the degassed liquid.

[0079] Without being bound by theory, it is believed that in the example illustrated in Figure **3**, liquid in the

upper portion **128** of the tubular interior chamber **122** has a higher ORP value as it has had a longer contact time with the ozone gas. It is further believed that this liquid can flow into the degassed liquid outlet **132** via the open top end of the degassed liquid region **136** without impediment. In contrast, in a gas-liquid separator having a degassed liquid region with a closed top end, it is believed that liquid in the upper portion **128** of the tubular interior chamber **122** would have to flow into the degassed liquid outlet **132** by first flowing down the center area, against the direction of flow of the remaining liquid.

[0080] One possible arrangement for securing both the mixing baffle **124** and the separating baffle **130** to the side wall is via holder **140**, which engages the side wall and the top ends of both the mixing baffle **124** and the separating baffle **122** so that none of the holder **140**, mixing baffle **124** and separating baffle **130** disengage from the side wall when the gas-liquid separator is subjected to vortex flow **112**.

[0081] Holder **140** and the side wall of the tubular chamber **122** defines apertures **142** through which fluid can flow into or out of the annular degassed liquid region **126** and further defines at least one center opening through which the gaseous liquid and bubbles can flow. Holder **140**, mixing baffle **136** and separating baffle **122** illustrate one example of a separating mixer **134** secured to the side wall.

[0082] Figure **4** is a view along line **4-4** of Figure **3**. Figure **4** shows the annular degassing liquid region **136**, the mixing baffle **124** and the apertures **126** defined therein. Figures **3** and **4** illustrate the mixing baffle **124** as being positioned concentrically with separating baffle **130** with the separating baffle **130** having a larger radius than the mixing baffle **124**. That is to say that the separating baffle and tubular interior chamber share a common longitudinal axis.

[0083] Although Figures **3** and **4** illustrate the separating baffle **124** and mixing baffle **130** as having a common center, it is to be understood that they would still be "positioned concentrically" as long as the longitudinal axis is shared, even if the mixing baffle **124** is positioned below the separating baffle **130** and they no longer share a common center.

[0084] As illustrated in Figure **3**, the degassed liquid outlet **132** can be a substantially annular aperture defined by the side walls of the substantially tubular interior chamber **122**. In other examples, the degassed liquid outlet **132** can be a plurality of apertures defined by the side walls of the chamber. In yet other examples, the degassed liquid outlet can be a tangential outlet in the side wall. The total cross-sectional area of the degassed liquid outlet **132** can be equal to or slightly larger than the cross-sectional area of the gas-liquid inlet **110**. For example, if the cross-sectional area of the gas-liquid inlet **110** is 78.5 mm² (e.g. a tube having a radius of 5 mm), then the degassed liquid outlet **132** can be an annular aperture having a vertical height of 0.5 mm if the substantially tubular interior chamber **122** has a radius of 25 mm (area = 2 π rh).

[0085] In examples where the degassed liquid outlet is an annular aperture defined by the side walls or a plurality of apertures defined by the side walls, the separating baffle can be annular in shape and define an annular degassed liquid region (as illustrated by element **136** in Figure **3**) between the separating baffle **130** and the side wall of the substantially tubular chamber **122**. The cross-sectional area of the annular degassed liquid region **136**, measured as the area between the separating baffle **130** and the side wall when viewed along the longitudinal axis of the interior chamber, can be 1.5x to 2.5x the cross-sectional area of the liquid-gas inlet **110** and/or the degassed liquid outlet **132**.

[0086] In examples where the degassed liquid outlet is a tangential outlet in the side wall, the separating baffle can be an annular baffle, one or more than one ribs or deflecting guides extending from the side or wall of the substantially tubular chamber, or the like.

[0087] An embodiment of a gas-liquid separator as described herein is illustrated in Figure **5**. As discussed with regard to the examples illustrated in Figures **3** and **4**, gaseous liquid enters a tangentially positioned gas-liquid inlet **110**, which is positioned in a lower portion **120** of tubular interior chamber **122**. The gas-liquid inlet **110** induces a vortex flow **112** of gaseous liquid. The gaseous liquid is injected at a flow rate sufficient to induce a vortex flow **112** of the gaseous liquid within the interior chamber **122**. Such a vortex flow **112** has a center of rotation and a low-pressure zone located at the center of rotation. The vortex flow **112** has a high-pressure zone around the periphery of the vortex flow **112**, for example where the liquid contacts the tubular interior chamber **122**.

[0088] The vortex flow **112** of liquid encounters separating baffle **130**, which is positioned in line with degassed liquid outlet **132**. Separating baffle **130** and the side wall of the tubular chamber **122** define degassed liquid region **136**. As discussed above, degassed liquid region is open at the top and bottom ends, and liquid can flow through the degassed liquid region **136** between the top and bottom ends.

[0089] As discussed previously, it is desirable to prevent bubbles of gas from exiting the gas-liquid separator through the degassed liquid outlet **132**. In a situation of vortex flow, where the degassed liquid outlet **132** is positioned in the high-pressure zone at the periphery of the vortex flow **112**, bubbles of gas can be swept into the degassed liquid outlet **132** before they coalesce in the low pressure zone. In order to direct bubbles of gas away from the degassed liquid outlet **132**, devices as described herein have a separating baffle **130** positioned in line with the degassed liquid outlet **132**. The liquid outlet **132** leads to collecting outlet **138**, which provides a flow of the degassed liquid.

[0090] As discussed with regard to the example illustrated in Figures **3** and **4**, the separated gas coalesces in the low-pressure zone to form bubbles, which further coalesce, leading to accumulation of the separated gas. The coalesced bubbles rise into the upper portion **128** of

the interior chamber **122** and exit out of separated gas outlet **144**. The separated gas outlet **144** allows the gas to escape the interior chamber **122** and is, therefore, positioned in the upper portion **128** of the interior chamber, where the separated gas would accumulate when the gas-liquid separator is use.

[0091] The gas-liquid separator can have a float (not shown) positioned in the interior chamber **122**. When in use, the float is pushed up by the liquid and closes off the separated gas outlet **144**. Separated gas accumulates and once sufficient gas collected, the float is displaced and separated gas outlet **144** is opened, allowing the collected gas to escape out of the separated gas outlet **144**. Once the separated gas has been vented, the float rises and again close off the separated gas outlet **144**. This allows the gas-liquid separator to maintain a relatively constant pressure within the interior chamber **122**.

[0092] It is to be understood that a mixture of gas and liquid is injected into a gas-liquid separator. This mixture of gas and liquid includes bubbles of gas mixed in with the liquid. In the context of the present application, such a mixture is termed a "gaseous liquid". Inside the gas-liquid separator, the gaseous liquid is separated into a "degassed liquid" and "separated gas".

[0093] In particular embodiments as described herein, the gas-liquid separator can promote dissolving the gas into the liquid. In particular embodiments as described herein, the gas-liquid separator can promote vaporizing or otherwise adding liquid to the gas. It is, therefore, to be understood that the degassed liquid can have gas dissolved therein, and/or the separated gas can have liquid added thereto.

[0094] The term "degassed liquid" is, however, understood to represent liquid substantially lacking bubbles therein, even if the liquid has a gas dissolved therein. The term "separated gas" is to be understood to be the gas when it has substantially coalesced together, even if the gas has liquid added thereto.

[0095] It is to be understood that devices, as described herein, separate gas and liquid at high flow rates. It is to be understood that the term "high flow rate", when used in the context of the overall flow capacity of a gas-liquid separator as described herein, would mean a flow rate of greater than four volumes per minute, where one volume is equal to the volume of the gas-liquid separator.

[0096] Gas-liquid separators, as described herein, generally operate in a substantially vertical orientation, with a gaseous liquid inlet stream entering a lower portion of the device, separated gas exiting the device via a separated gas outlet in an upper portion of the device, and degassed liquid exiting the device via a degassed liquid outlet positioned between the gas-liquid inlet and the separated gas outlet.

[0097] The terms "upper" and "lower" are understood to refer to relative portions of the device when the device is positioned as it would be when it is in use. The term "lower portion" refers to the portion of the gas-liquid sep-

arator which through in which gaseous liquid and degassed liquid flow. The term "upper portion" refers to the portion of the gas-liquid separator in which the separated gas is collected before being vented out of the separator. In particular embodiments, the lower portion is conical or frustoconical with a half angle between about 5 and 7 degrees.

[0098] As illustrated in Figures 3, 4 and 5, the gas-liquid inlet 110 can be positioned substantially tangential to the interior chamber 122. However, it is to be understood that vortex flow 112 can be induced by methods other than the tangential entry of the gaseous liquid. For example, a gaseous liquid inlet can be positioned coaxial to the central longitudinal axis if the inlet includes a flow-deflection component to deflect axially inflowing liquid so that the desired vortex flow is induced.

[0099] One example of a flow-deflection component is a rotation-symmetrical base body element as described in U.S. Patent No. 6,053,967. This flow deflection component includes deflection vanes, which are curved in planes perpendicular relative to the longitudinal axis of the chamber, to direct the axially inflowing water to form the desired vortex flow. Additionally, it is to be understood that vortex flow can be induced through mechanical methods, such as by the positioning of a motor-driven paddle in the substantially tubular chamber, where the motor-driven paddle drives vortex flow through physical displacement of the liquid.

[0100] In view of the desire to create a vortex flow inside the interior chamber, the term "substantially tubular interior chamber" is to be understood to mean a chamber that is shaped to encourage, not deter, a vortex flow. A chamber that deters a vortex flow may, for example, have a substantially square or rectangular horizontal cross-section since the side walls would discourage the flow of liquid circularly around the interior chamber. In contrast, a chamber that encourages a vortex flow could, for example, have a substantially oval or circular horizontal cross-section since the side wall(s) would direct the flow of liquid around the interior chamber. It is understood, however, that chambers with square or rectangular cross-sections can include other features that encourage vortex flow. In such situations, it is to be understood that the term "substantially tubular interior chamber" would encompass those chambers.

[0101] Ozone Source. Ozone gas can be provided to the liquid-gas mixer (e.g. venturi 14 in Figure 1) from a number of different sources. For example, a corona discharge system can be used to generate and provide the ozone gas. A corona discharge system uses an electrode with a high potential and takes oxygen gas and passes a current through the gas so as to ionize the gas and create a plasma around the electrode. The ionized gas recombines with oxygen to form ozone. The oxygen gas used in a corona discharge system can be oxygen from the air or from another oxygen source, for example the output from an oxygen concentrator. If air is used to generate ozone gas, a higher concentration of ozone can be

achieved by reducing the amount of moisture in the provided air and/or increasing the concentration of oxygen (for example by removing nitrogen) in the provided air. Reducing the amount of moisture or increasing the concentration of oxygen can be achieved, for example, by using a removable cartridge, as described below. Corona discharge systems can use sustained ionization or intermittent ionization to generate ozone. Corona discharge typically uses two asymmetric electrodes: a highly curved electrode (e.g. tip of a needle or small diameter wire) and an electrode with a low curvature (e.g. a plate or ground). Coronas may be positive or negative, depending on the polarity of the voltage on the highly curved electrode. In particular embodiments, a negative corona discharge system is used. In some embodiments of known corona discharge systems, as much as 10 grams of ozone per hour can be provided.

[0102] Ozone Destructor. Systems according to the present application may also include an ozone destruction assembly, or "ozone destructor", as illustrated by element 20 in Figure 1. Ozone destructors are known in the art. Briefly, the ozone destruction assembly can include a gas inlet for accepting ozone gas from the gas-liquid separator 18. Ozone gas can be directed from the gas inlet to a destruction chamber with a catalyst for accelerating the decomposition of ozone into oxygen. The decomposition can be further accelerated by heating the destruction chamber and/or the ozone gas to be destroyed to an elevated temperature. In particular embodiments of the ozone destruction assembly, the catalyst is manganese dioxide or activated carbon. The resulting oxygen gas produced from the destruction of the ozone gas can be discharged to the atmosphere via an oxygen outlet.

[0103] Scrubber/Extractor. The system for providing ozonated liquid according to the present application can be adapted or retrofitted to a mobile floor scrubber or extractor. Scrubbers and extractors are floor cleaners which eject a cleaning solution from a reservoir of clean liquid onto the floor and then remove the solution by vacuuming it into a reservoir of dirty liquid. Scrubbers and extractors are typically used in hospitals, hotels or other commercial or industrial settings.

[0104] When adapted to scrubbers or extractors, the contemplated system takes water from the clean reservoir as the liquid to be ozonated, passes the water through the ozonation flow path, and ejects the ozonated water as the cleaning solution. Used ozonated water vacuumed from the floor is then stored in a dirty reservoir until the scrubber or extractor is emptied.

[0105] One example of a scrubber 210 is illustrated in Figure 6. The scrubber 210 has a clean reservoir 212 holding water to be ozonated 214. The water to be ozonated 214 passes through inlet 216 in order to enter the ozonation flow path. The water flows at a desired flow rate through venturi 218. Venturi 218 mixes the water with ozone produced in ozone generator 220 to provide an ozone-water mixture, which flows through gas-liquid

separator **222**. The gas-liquid separator **222** separates the mixture into gaseous ozone and ozonated water. The gaseous ozone passes through ozone destructor **224** before being vented as oxygen. The ozonated water passes through outlet **226** as it leaves the ozonation flow path to be used by the scrubber as the cleaning solution. The scrubber **210** can include scrubbing brushes **228** which use the ozonated water to scrub the floor, resulting in dirty ozonated water. The dirty ozonated water **230** is sucked into dirty reservoir **232** via vacuum inlet **234**.

[0106] In particular embodiments, the system can be adapted to interface with a commercially available scrubber or extractor. In such situations, it is desirable to ozonate water after it leaves the clean reservoir, instead of ozonating all of the water in the clean reservoir as a recirculating ozonating system would do. To achieve this, a system according to the present application can be installed downstream from the clean reservoir and upstream from the scrubbing brushes. Installing the system in a hose connecting the clean reservoir and scrubbing brushes allows the system to provide ozonated water on demand.

[0107] Ozonation. In ozonation systems according to embodiments of the present application, since the ozonation flow path is non-recirculating, the liquid passes through the ozonation flow path only once before being dispensed from the liquid outlet. The ozonation flow path must, therefore, dissolve sufficient ozone in the liquid in a single pass to provide the ozonated liquid.

[0108] In particular embodiments of the ozonation system according to the present application, the liquid accepted by the ozonation flow path is substantially unozonated. "Substantially unozonated" is to be understood to mean that the accepted liquid does not exceed a threshold value. In particular embodiments, the threshold value can be an ORP value of about 250 millivolts (mV), preferably about 150 and more preferably about 50 mV. It is appreciated that the threshold value can alternatively be measured in ppm of dissolved ozone, and the threshold value can be about 0.1, preferably about 0.05, more preferably about 0.02 and even more preferably about 0.01 ppm of dissolved ozone.

[0109] For example, an ozonation flow path according to the present application can take an accepted liquid having 0 ppm dissolved ozone and an ORP of 0 mV and, passing the fluid through the ozonation flow path only once, dispense an ozonated liquid having at least about 8 ppm ozone and/or an ORP due to the dissolved ozone of at least about 900 mV. A similar final amount of dissolved ozone and/or a final ORP value can be observed in the dispensed ozonated liquid when the accepted liquid already has a non-zero amount of dissolved ozone and/or a non-zero ORP.

[0110] It is appreciated that "ozonated liquid" can generally refer to liquid with any amount of ozone dissolved therein. However, in the context of the present application, when the liquid is water or a water-additive mixture, the term "ozonated liquid" is to be understood to be liquid

that has sufficient ozone dissolved therein that the oxidation-reduction potential (ORP), solely due to the dissolved ozone, is at least about 450 mV.

[0111] In particular embodiments, the ORP solely due to the dissolved ozone is at least about 600, 750, 800, 850, 900, 950, 1000, 1050, 1100 or 1150 mV. It is appreciated that an alternative definition for "ozonated liquid" according to another embodiment is a liquid that has sufficient ozone dissolved therein to reach a concentration of at least 3 parts per million (ppm), and preferably at least 4, 5, 6, 7, 8, 9 or 10 ppm.

[0112] Oxidation-reduction potential is a measure of disinfectant levels in water systems, independent of the oxidant (e.g. ozone, chlorine, peroxide, peroxyacetic acid). It is generally accepted that liquids with ORP values of 650 to 700 mV kill bacteria within a few seconds. Yeast and other fungi can be killed with such a liquid upon contact for a few minutes. Liquids with an ORP value of 450 mV are termed "sanitizing liquids". Liquids with an ORP value of 600 mV are termed "disinfecting liquids". Liquids with an ORP value of 800 mV are termed "sterilizing liquids".

[0113] An ORP value "due solely to dissolved ozone" is to be understood to mean that the ORP is a measure of the oxidation potential of the dissolved ozone and does not take into account the oxidation and/or reduction potential of other additional components of the liquid. For example, chlorine dissolved in water has an oxidation potential. Adding ozone to the chlorinated water would increase the ORP. In this example, the ORP value "due solely to dissolved ozone" corresponds to the ORP value of the water if it was not chlorinated, regardless of the ORP value of the ozonated and chlorinated water.

[0114] In contrast to holding tank-less systems according to the present application, ozonation systems having a recirculating ozonation flow path only dissolve a small amount of ozone every time the liquid travels through the recirculating flow path. Repeatedly recirculating the liquid adds a small amount of ozone every time the liquid is recirculated, eventually resulting in a larger amount of dissolved ozone and higher ORP value.

[0115] Pressure. Ozonation systems according to the present application can be connected to a municipal water supply. Typical municipal water supplies provide water at a pressure between approximately 138 kPa (20 psi) and approximately 414 kPa (60 psi). An ozonation system according to the present application accepts water from the municipal water supply or from another water source (for example from a pressurized holding tank). In some instances, for example if water is accepted from a pressurized tank, water may be provided at pressures as high as 552 kPa (80 psi) or 686 kPa (100 psi). In the example shown in Figure 1, the accepted water enters the liquid inlet **12** at the desired flow rate and accepted pressure and travels through the ozonation flow path, which does not include any pressure regulation systems, for example pressure reducing valves or pressure pumps. In an embodiment, the ozonated water dis-

pensed from the system has a dispensing pressure that is directly dependent on the accepted pressure.

[0116] Flow Rate. The accepted water flows into the liquid inlet of the ozonation flow at a desired flow rate, which is a function of the water pressure and cross-sectional area of the liquid inlet. The desired flow rate typically ranges from 3 to 10 liters per minute, but can be as high as about 38 liters per minute. In the example shown in Figure 1, the accepted water enters the liquid inlet 12 at the desired flow rate and accepted pressure and travels through the ozonation flow path. In an embodiment, the flow rate of the ozonated water dispensed from the system is the same as the flow rate accepted by the system.

[0117] Residence Time. A system with a "holding tank" is to be understood to be a system with a reservoir, for example a vessel, tank, pipe, pool, drum or any other container, for storing, accumulating or saving liquid until it is needed. A systems that is "holding tank-less" is to be understood to be a system that does not store, accumulate or save liquid until it is needed. In such a holding tank-less system, liquid would be accepted into the system, flow through the flow path, and be dispensed from the system without being placed in a reservoir.

[0118] Since the ozonation flow path does not have a holding tank for producing ozonated liquid on a recirculating basis, the overall volume of the system is small in comparison to the flow rate of dispensed ozonated liquid. The ratio between volume and flow rate is understood to be a measure of the average fluid residence time of the liquid in the ozonation flow path.

[0119] The fluid residence time of a system is an expression of how long it takes a fluid element to move through a volume which is in equilibrium. It is to be understood that fluid residence time is a measure of the residence time of the liquid in that volume. It is the average time a fluid element spends within a specified region of space, such as a reservoir. In a well-mixed system with all fluid elements in equilibrium, residence time can be calculated by dividing the volume in question by the volumetric flow rate of the liquid. Examples of the present application have an average fluid residence time of the liquid in the ozonation flow path of less than about 5 minutes. In other particular embodiments, the average fluid residence time is less than about 1, about 0.7 or about 0.05 minutes.

[0120] In particular instances of the ozonation system described herein, the ozonation system has a liquid inlet and a liquid outlet, with the ozonation flow path therebetween. The ozonation system according to the present application includes an ozonation flow path with a liquid inlet and liquid outlet.

[0121] For example, in one example, the liquid inlet can correspond to the nozzle which accepts liquid into the ozonation system and the fluid residence time is measured from the nozzle to the liquid outlet which dispenses ozonated liquid from the ozonation system. In another particular example, the liquid inlet corresponds

to the liquid-gas mixer and the fluid residence time is measured from the liquid-gas mixer to the liquid outlet which dispenses ozonated liquid from the ozonation system.

5 **[0122]** In one particular example of an ozonation flow path according to the present application, a venturi mixer is joined to a gas-liquid separator by 3" of 3/8" tubing. In such an example, and at average flow rates, the average residence time between the venturi mixer and the gas-liquid separator is in the range of about 0.01 and about 10 0.1 seconds. In such an example, the average residence time in the ozonation flow path can be less than about 0.7 or less than about 0.05 minutes, depending on the flow rate of the liquid.

15 **[0123] Cartridge and usage tracking.** As discussed, water ozonation devices (such as a holding tank-less water ozonation system) can optionally use a removable filter cartridge when the ozonation device includes an ozone source such as, for example, a corona discharge 20 system. The removable filter cartridge can be used to increase the concentration of ozone generated by the corona discharge system by reducing the amount of moisture in the provided air and/or increasing the concentration of oxygen (for example by removing nitrogen) 25 in the air provided to the corona discharge system.

[0124] The cartridge can be arranged for integration and use with first and second ozonation devices, and can include a usage counter to increment a usage count in response to a received signal from an ozonation device, 30 and a device interface to provide an expiry indication when the cartridge is no longer suitable for use. The devices count usage can be based on different first and second cycle count conditions. The same cartridge can be used in different devices, such as, for example, a consumer water ozonation device (such as described in U.S. Patent No. 6,964,739), a high capacity commercial water 35 ozonation device, a large volume ozone sprayer, a holding tank-less water ozonation device, etc. The devices can include logic to disable usage of the system after the cartridge has reached a predetermined usage condition. 40 Compatibility identifiers can be used in the cartridge and devices to restrict use of the cartridge with certain devices.

[0125] While some known systems offer a limited type 45 of usage tracking or counting, examples described herein count usage of a cartridge in a way that permits the cartridge to be used, and re-used, in systems having a different type, or which measure usage cycles differently. This can be described as providing universal usage 50 counting in a water treatment system having a plurality of ozonation devices which count usage according to different cycle completion conditions.

[0126] In one instance, a cartridge-enhanced water treatment system including a cartridge and first and second 55 ozonation devices is described. The first and second ozonation devices can be the same or different. For example, the first and second ozonation devices can be first and second holding tank-less ozonation devices; or

the first ozonation device can be a holding tank-less ozonation device and the second ozonation device can be a residential ozonation device (such as described in United States Patent Application Publication No. US-2008-0190825-A1).

[0127] The first ozonation device is of a first type, and includes a first device cycle count manager configured to signal the cartridge upon completion of an ozonation cycle of the first ozonation device with respect to a first ozonation device cycle count condition. The second ozonation device is of a second type, the second type being different from the first type. The second ozonation device includes a second device cycle count manager configured to signal the cartridge upon completion of an ozonation cycle of the second ozonation device with respect to a second ozonation device cycle count condition.

[0128] In one example, the cartridge is a desiccant cartridge, and is arranged for integration and independent use with both the first ozonation device and the second ozonation device, and includes: an air inlet to receive atmospheric air, a desiccant material to remove moisture, and a dry air outlet for interfacing with one of the first and second ozonation devices to provide dry air to an ozone generator. In another example, the cartridge is a nitrogen-removing cartridge, is arranged for integration and independent use with both the first ozonation device and the second ozonation device, and includes: an air inlet to receive atmospheric air, a material to remove nitrogen gas from the air so as to increase the concentration of oxygen in the air, and an oxygen-enriched air outlet for interfacing with one of the first and second ozonation devices to provide oxygen-enriched air to an ozone generator. In yet another example, the cartridge is both a nitrogen-removing and desiccant cartridge, and includes both a desiccant material to remove moisture and a material to remove nitrogen gas from the received air.

[0129] The cartridge further includes a usage counter arranged to modify a stored usage count in response to receipt of a signal from the first or second cycle count manager, and a device interface arranged to provide an expiry indication indicating that the cartridge is no longer suitable for further use, based on the stored usage count. The cartridge can optionally include a chronological counter arranged to modify a stored time count. The device interface in such a cartridge can provide an expiry indication based on the stored usage count or the stored time count. In a cartridge that includes a chronological counter, the cartridge could be stored in a vacuum packed container and, once the container is opened and the cartridge exposed to atmospheric air, the chronological counter could be started by the removal of a tab. Removal of the tab could, for example, engage a battery with dedicated circuitry for modifying the stored time count.

[0130] The first and/or second cycle count managers can comprise a cycle memory arranged to keep track of partially completed cycles.

[0131] In an example, the cartridge includes a cartridge

compatibility identifier, and the first and second ozonation devices include first and second device compatibility identifiers, respectively. First and second device compatibility managers are arranged to determine whether the cartridge is compatible with the first or second ozonation device, respectively, based on a comparison of the cartridge compatibility identifier with the first and second device compatibility identifiers, respectively.

[0132] The first and second device compatibility managers can determine that the cartridge is compatible with the first or second ozonation device when the cartridge compatibility identifier is the same as the first or second ozonation device compatibility identifier, respectively. Therefore, in an example, if the cartridge is compatible with the first and second ozonation devices, all three have the same compatibility identifier.

[0133] The first and second device compatibility managers can determine that the cartridge is compatible with the first or second ozonation device when the first or second ozonation device compatibility identifier identifies a device class with which the cartridge compatibility identifier is compatible. The cartridge can then be compatible with a plurality of types of ozonation device of the identified device class.

[0134] The usage counter (with the optional chronological counter) in the cartridge can be reset in response to receipt of a usage and/or chronological counter reset signal. The system can further include a usage counter reset manager (with an optional chronological counter reset manager), in communication with the cartridge, arranged to send a usage and/or chronological counter reset signal to reset the usage and/or chronological counter in the cartridge. The usage counter reset manager and/or chronological counter reset manager can be arranged to determine an expected life of a dried desiccant material and/or a nitrogen-removing material prior to sending the usage and/or chronological counter reset signal. The usage and/or chronological counter reset managers can be arranged to provide a modified value with which the usage and/or chronological counters can be reset, the modified value being based on measured properties of the desiccant material and/or the nitrogen-removing material.

[0135] In another instance, a cartridge arranged for integration and use with first and second ozonation devices of different types, and including: an air inlet to receive atmospheric air; a desiccant and/or nitrogen removing material to remove moisture and/or nitrogen; an air outlet for interfacing with one of the first and second ozonation devices to provide dry and/or oxygen enriched air to an ozone generator; and a usage and/or chronological counter, is described. The usage counter (with an optional chronological counter) is arranged to modify a stored usage count in response to receipt of a first cycle completion signal received from the first ozonation device representing completion of an ozonation cycle with respect to a first ozonation device cycle count condition. The usage counter is also arranged to modify the stored usage count

in response to receipt of a second cycle completion signal received from the second ozonation device representing completion of an ozonation cycle with respect to a second ozonation device cycle count condition. The cartridge also includes a device interface arranged to provide an expiry indication indicating that the cartridge is no longer suitable for further use based on the stored usage count. In cartridges with the optional chronological counter, the chronological counter is arranged to modify a stored time count. The device interface in such a cartridge can provide an expiry indication based on the stored usage count or the stored time count. In a cartridge that includes a chronological counter, the cartridge could be stored in a vacuum packed container and, once the container is opened and the cartridge exposed to atmospheric air, the chronological counter could be started by the removal of a tab. Removal of the tab could, for example, engage a battery with dedicated circuitry for modifying the stored time count.

[0136] Fig. 7 is a block diagram of a cartridge-enhanced water treatment system **300** including a first ozonation device **310**, a second ozonation device **320** and a cartridge **330**. The first ozonation device **310** includes a cycle count manager **312**, and optionally includes a compatibility identifier **314**, and a compatibility manager **316**.

[0137] The cycle count manager **312** is configured to signal the cartridge **330** upon completion of an ozonation cycle of the first ozonation device **310**. The cycle count manager **312** is particularly configured with respect to a first ozonation device cycle count condition, such as a cycle count threshold. For example, if the first ozonation device **310** is a high capacity ozonation device or system, the cycle count manager **312** can be configured to signal the cartridge **330** after 45 seconds of operation. In this case, the first ozonation device cycle count condition, or threshold, is 45 seconds of operation.

[0138] The cycle count manager **312** can include a cycle memory, to keep track of partially completed cycles. For example, suppose an ozonation device has a cycle count threshold of 45 seconds. If the ozonation device runs for 30 seconds and the device is stopped, the cycle count manager memory will store the partially completed cycle information. When the ozonation device next starts, it calculates after 15 seconds of operation that a cycle has been completed, based on the partially completed cycle information.

[0139] The cycle count manager **312** maintains the cycle memory value when the cartridge is removed from a first ozonation device of a first type and is installed in a second ozonation device of the same type. For example, if the two ozonation devices use the same ozonation device cycle count condition, the cycle memory value is maintained. If the cartridge is subsequently installed on an ozonation device of a different type, or which uses a different ozonation device cycle count condition, the cycle memory can be converted based on a relationship between the two conditions, or can be cleared if such

conversion cannot be completed.

[0140] The compatibility identifier **314** is an identifier that can be used within a cartridge-enhanced water treatment system to identify compatible cartridges and water ozonation devices. The identifier **314** can also be referred to as a first device compatibility identifier. The compatibility manager **316** determines whether a cartridge is compatible with the first ozonation device based on stored compatibility identifiers. The compatibility manager **316** can determine that the cartridge is compatible if it has the same compatibility identifier as the first ozonation device. Alternatively, a positive determination can be made if the cartridge and device compatibility identifiers have another predetermined relationship with each other, for example are the opposite of each other.

[0141] The second ozonation device **320** also includes a cycle count manager **322**, and optionally a compatibility identifier **324** and compatibility manager **326**, which are similar to the above-described cycle count manager **112**, compatibility identifier **314**, and compatibility manager **316**. The cycle count manager **322** is configured to signal the cartridge **330** upon completion of an ozonation cycle of the second ozonation device **320**.

[0142] The cycle count manager **322** is particularly configured with respect to a second ozonation device cycle count condition. For example, suppose the second ozonation device **320** is a low capacity commercial ozonation device capable of performing two or more different ozonation cycles, associated with different types of container or attachment used. The second ozonation device cycle count condition can then be different depending on the selected ozonation cycle.

[0143] For example, a second ozonation device cycle count condition for a vegetable bowl cycle can include achieving a desired ozone concentration in the water during a running time of about 3 to 4 minutes. In that case, the second ozonation device cycle count condition can be dependent on a detection of an ozone concentration in the water, as compared to a desired ozone concentration for a particular cycle, and optionally within an operation time window. Regardless of the potential variation in the actual time taken to complete the cycle, the cycle count manager **326** can be configured to signal the cartridge **330** after meeting one or more conditions to satisfy completion of a second ozonation device cycle.

[0144] If the first and second ozonation device compatibility identifiers **314** and **324** are the same, then this signifies that a cartridge having that compatibility identifier will work and be compatible with both the first and second ozonation devices **310** and **320**.

[0145] The cartridge **330** includes an air inlet **332**, an air outlet **334**, and houses at least one material **336** to remove moisture and/or nitrogen. The cartridge is arranged for integration and use with the first ozonation device with the second ozonation device. The air inlet **332** is to receive atmospheric air, and the air outlet **334** is for interfacing with one of the first and second ozonation devices to provide dry and/or oxygen-enriched air to an

ozone generator.

[0146] The cartridge **230** includes a usage counter **338**, a stored usage threshold **340**, and includes a device interface **342**. The usage counter **338** modifies a stored usage count in response to receipt of a signal from the cycle count manager **316** or **326**. The modification of the usage count can include incrementing or decrementing the count, depending on the implementation of the counter. The usage counter **338** can be implemented in a flash memory, or other computer-readable memory or computer-readable medium.

[0147] The usage threshold **340** is stored in a memory in the cartridge **330**. The cartridge usage threshold **340** can be programmable, so that a manufacturer can program different thresholds for different cartridges. The programmability of the cartridge cycle threshold differs from other known cartridges with fixed counts. For instance, certain customers want to change the cartridge after 650 cycles based on their usage conditions and requirements, and others want to change after 800 cycles based on different usage conditions and requirements.

[0148] For example, with a commercial ozonation device including a trigger sprayer, 650 cycles can be run before the cartridge is marked as expired. The trigger sprayer sends a signal to the cartridge to remove a cycle every time the system is run. With a high capacity ozonation device, the cartridge lasts for 1,200 gallons. Typical flow can be about 2.5 gallons/minute. A cycle can be removed from the cartridge every 45 seconds. The cartridge itself receives a signal (in both cases) to remove a cycle from its count. Each system in turn uses different parameters to determine when to send this cycle completion signal.

[0149] If the usage count stored in the usage counter **338** exceeds the stored usage threshold, the cartridge can provide an expiry indication to the device interface **342**, indicating that cartridge is no longer suitable for further use. The device interface **342** can provide the expiry indication in a format readable by the ozonation device in which the cartridge is used. In an embodiment, the expiry indication is a separate indication provided to, and stored in, the device interface **342**.

[0150] Suitably, the usage count begins at the maximum capacity value, and is decremented until it reaches zero. In this case, the first and second ozonation devices signal the cartridge to decrease, or decrement, the usage count by one upon completion of an ozonation device cycle count condition. The providing of a usage count of zero can be an embodiment of providing an expiry indication to the device interface **342**.

[0151] The usage counter increments upon cycle completion. If the usage count exceeds the usage threshold, the cartridge can change the usage counter to read "999" or some other value that indicates to the compatibility manager that the cartridge is not to be used.

[0152] The usage counter **338** can be reset, and the desiccant material **336** in the cartridge **330** can be dried, thus permitting re-use and recycling of the cartridge. In

an example, the usage counter **338** can be reset in response to receipt of a usage counter reset signal. The usage counter reset signal can be received from an ozonation device with which the cartridge is to be used, or from another specialized device including dedicated circuitry to reset the cartridge.

[0153] The ozonation device or the specialized device can comprise a usage counter reset manager, in electrical communication with the device interface **342** of the cartridge when the cartridge is in use or is in place for usage counter resetting. The usage counter reset signal can be issued after a determination has been made that the desiccant material has been sufficiently dried for re-use. Optionally, the usage counter reset manager can determine an expected life of the dried desiccant material. The usage counter reset manager can provide a modified value with which the usage counter can be reset, the modified value being based on measured properties of the desiccant material.

[0154] An advantage of providing the usage counter reset manager as part of a specialized device, such as a usage counter resetting apparatus, is to remove the ability of users of the ozonation devices to reset the usage counter. In an example where the usage counter reset manager is provided in the ozonation device, an access controller can be provided to restrict access to the usage counter reset manager. The access controller can be implemented as any mechanical and/or electrical form of access control, such as a physical key, a security card access control, a biometric identifier, etc.

[0155] The cartridge **330** optionally includes a compatibility identifier **344**, also referred to as a cartridge compatibility identifier **344**. Based on a comparison between the cartridge compatibility identifier and the first or second ozonation device compatibility identifier, a determination is made whether the cartridge is compatible with the device. For example, if the cartridge compatibility identifier **344** is the same as the first or second compatibility identifiers **314** and **324**, then that cartridge is activated or enabled for use with the first or second ozonation devices, respectively.

[0156] The compatibility identifiers **314**, **324** and **344** can each be stored as a line of code in a memory provided in the first and second ozonation devices **310** and **320**, and the cartridge **330**, respectively. If the stored cartridge and device compatibility identifiers correspond, or are the same, then the water ozonation device permits use of the cartridge in the device. This permits a manufacturer to identify or encode cartridges for use only with apparatuses produced by a particular distributor or for a particular reseller. The cartridge can be used with water ozonation devices of different types, for example low capacity and high capacity commercial devices, as long as the devices have the same identifier as the cartridge.

[0157] Examples have been described herein with respect to different types of commercial ozonation devices and systems. Such commercial devices can include a commercial floor scrubber, or a carpet extractor,

equipped with a liquid ozonation device as described herein. The features described herein may be incorporated in other classes of ozonation devices or systems, such as industrial or consumer ozonation devices. The compatibility identifier can be used to ensure that a cartridge is compatible only with different types of ozonation devices of the same class. For example, a consumer compatibility identifier, commercial compatibility identifier, or industrial compatibility identifier can be included in cartridges to be used with one of those classes of ozonation devices having the same, or a corresponding, compatibility identifier.

[0158] The cartridge-enhanced water treatment system **300** can include logic to disable usage of an ozonation device after the cartridge has reached a predetermined usage and/or chronological condition or threshold. This condition may be different depending on the type of ozonation device in which the cartridge is used. The logic can be provided in the first and second ozonation devices **310** and **320**, and/or in the cartridge **330**.

[0159] For example, when a cartridge is inserted and an ozonation device is turned on, a base unit of the ozonation device can read the cartridge identifier and check to make sure that the code matches what has been pre-programmed on the control board in the base unit, or otherwise results in a positive compatibility determination. If it does not, then the unit will not run. A similar methodology can apply with respect to reading the usage and/or chronological count, and not permitting the device to operate when the usage or chronological count exceeds the programmed threshold.

[0160] Fig. **8A** is a front right perspective view of a cartridge. The usage counter **338**, the usage threshold **340**, and the optional compatibility identifier **344** are in electrical communication with the device interface **342**, such as wired communication, wireless communication, or infrared (IR) communication. In Fig. **8A**, one, some, or all of the usage counter **338**, the usage threshold **340**, the optional compatibility identifier **342**, and the device interface **344** can all be provided in a printed circuit **346** provided on an outer surface of the cartridge, which mates with the ozonation device. Fig. **8B** shows an exploded view of a cartridge. The printed circuit **346** can include the features noted above with respect to the example of Fig. **8A** and the cartridge can be disassembled and the desiccant material, the nitrogen removing material and/or the battery for powering the printed circuit **346** can be replaced.

[0161] Fig. **9** is a mechanical system diagram of an exemplary water sanitization system with which a cartridge can be used. The system illustrated in Fig. **9** shows both water and air paths, and illustrates a filter that can perform air dryer and water filtration. This system is described herein for illustration, as a background for understanding the operational environments. Another exemplary water sanitization system with which a cartridge could be used is the system illustrated in Fig. **1**, where the cartridge can be used with ozone generator **16**.

Ozone generator **16** of Fig. **1** and ozone generator **416** of Fig. **9**, discussed below, can be used interchangeably.

[0162] While the examples above have described a cartridge which can perform air drying, such functionality can be provided in a removable filter cartridge that also provides water filtration. In discussions of Fig. **9**, the terms "after" and "before" are used with respect to the water or air flow within the system. The direction of water flow is illustrated at pump motor **406**, whereas the direction of air flow is illustrated at air dryer **410**.

[0163] A reservoir **402** is provided for containing water that is to be, or is being, sanitized/purified. The reservoir **402** is a removable water container. Examples of such containers are discussed in commonly assigned International Patent Application No. WO 2004/113232, published on December 29, 2004. A fluid transfer port or valve **404** is provided at the interface of the reservoir **402** with a base unit incorporating the other elements of the system according to an embodiment of the present invention. The fluid transfer valve **404**, or fluid control port or liquid interface, allows the control of fluids, and in particular, but not limited to, the control of fluids into and out of the container, which allows the container to be removed without leaking.

[0164] The flow into and out of the container may occur simultaneously or sequentially. In the case of simultaneous outflow and inflow, water is taken from the reservoir **402**, processed, and pumped back to the reservoir. This is preferably done in such a way that the fluid level in the reservoir is maintained during processing (i.e. the fluid is not drained from the reservoir, processed and then pumped back into the reservoir). The fluid transfer valve **404** can be implemented in any number of ways, such as by way of separate check valves for inflow and outflow, or a single double check valve (DCV) for both inflow and outflow. The double check valve arrangement allows water to flow out of and into the container simultaneously while using a single connection point.

[0165] In order to improve mixing, a DCV cap (not shown in the figures) can be provided at the fluid transfer valve when it is implemented as a double check valve. An angled section of the DCV cap can preferably be removed to allow the water entering the reservoir from the base unit to be less impeded and therefore faster moving. This faster moving water causes greater mixing in the reservoir and means the dissolved ozone level gets up higher and faster in the reservoir.

[0166] Water flows from the reservoir **402**, through the fluid transfer valve **404** to a pump motor **406** provided after the reservoir **402** to draw water from the reservoir. Although the pump head and motor functions can be separated, they are typically implemented in a unitary motor/pump assembly, such as the pump motor **406**, and will be discussed as such herein, keeping in mind that other implementations are possible. The electronics are typically connected to the motor portion, but the pump and motor are interconnected.

[0167] A replaceable cartridge **408**, which is remova-

ble and preferably disposable, is described. The cartridge **408** can include an air dryer **410** for function in the air flow path, or air line, of the system and/or a water filter **412** for function in the water flow path, or water line, of the system. In terms of air circulation in the system, air typically is drawn in from the atmosphere via the air dryer **410**, and can then pass through an inlet valve **414**, an ozone generator **416**, an outlet valve **418**, and an ozone contacting device, or mixing device, **420**, such as a venturi.

[0168] The inlet and outlet valves **414** and **418**, alternatively referred to as transfer ports, are optional components of the system and can be implemented as check valves. They serve to improve performance of the system, and particularly the ozone generator **416**. The valves **414** and **418** co-operate to ensure that when the unit is not running, little or no residual ozone gas can diffuse out of the system to atmosphere. Some governmental safety guidelines and regulations include a virtual no ozone gas emissions requirement. The valves **414** and **418** assist in achieving such requirements. The outlet valve **418** prevents water from backing up into the ozone generator **416** via the ozone contacting device **420** when the unit is at rest with a reservoir, or attachment, on it.

[0169] The ozone generator **416**, which can be a corona-discharge type, converts a portion of the oxygen in the air (drawn from the atmosphere) into ozone. The ozone is mixed with the water in the ozone contacting device **420**. The water ozone mixture then preferably passes through an ozone gas atomizer **422** before passing into an off-gas unit **424**, which removes the air and undissolved ozone. The removed gas is directed to an ozone destructor **426**, which converts ozone into oxygen and safely releases it into the atmosphere.

[0170] The ozone gas atomizer **422** is provided downstream of the ozone contacting device **420** and just before the inlet port of the off-gas unit **424** in order to increase the contact time between the micro bubbles of ozone gas and the water. The geometry of a preferably necked down inlet port of the off-gas and the cyclonic action of the gas/liquid mixture in the off-gas unit **424** makes the off-gas unit **424** also act as a mixing device. This feature can significantly increase the dissolved ozone level in the water. An accumulator (not shown in the figures) can preferably be provided at the top of the off-gas unit **424** that captures excess water that escapes out of the off-gas unit **424** via the gas line. This accumulator can drain the excess water back into the off-gas unit **424** when the unit is at rest. Having this accumulator prevents water from getting into ozone destructor **426** when the unit is inverted. If the ozone destructor **426** (such as provided by CARULITE®) gets wet, it is rendered ineffective at destroying ozone gas.

[0171] A sealing check valve (not shown in the figures) can preferably be provided between the off-gas unit **424** and the ozone destructor **426**. This sealing check valve seals the system from atmosphere in such a way that when the unit is inverted in an attempt to drain water out

of it, water is prevented from leaving the system. It is the same principle as inserting a straw in a drink, covering the end of the straw and then removing the straw - the drink stays trapped in the straw. This is advantageous in a unit described herein as it can keep all components wet and the pump primed.

[0172] As described earlier with respect to Fig. **9**, a removable filter cartridge is described in a base unit of a water sanitization system. The removable filter cartridge **408** can include an air dryer **410** and optionally a water filter **412**. In certain examples, the removable filter cartridge **408** can include a nitrogen remover and optionally a water filter **412**. In other examples, the removable filter cartridge **408** can include both an air dryer **410** and a nitrogen remover, and can optionally include a water filter **412**. As mentioned earlier, it is advantageous that dry air and/or oxygen-enriched air reacts better in an ozone generator, yielding better ozone concentration output, which in turn results in a better "kill rate" with respect to bacteria when ozonated water is applied to food, items or surfaces.

[0173] Suitably, the removable filter cartridge includes an air dryer **410** and does not include a water filter. The air dryer **410** comprises a desiccant material that removes moisture from air.

[0174] The air dryer **410** can be placed anywhere in the base unit as long as it is before the ozone generator **416** and the ozone contacting device **420** with respect to air flow. The ozone contacting device **420** draws air from the atmosphere into the air dryer **410** and then into the ozone generator **416**. Dry air can achieve much higher concentrations of ozone gas than humid air in a corona discharge ozone generator. As such, a significant increase to the concentration of dissolved ozone in the water can be achieved. An examination of experimental test results shows an increase in ozone concentration from approximately 1 ppm without the air dryer to over 3.5 ppm with the air dryer.

[0175] Although Fig. **9** illustrates an example where fluid is recirculated (i.e. transported from a reservoir, to an ozone contacting device and returned to the reservoir), a cartridge could also be used in a non-recirculation system. In a non-recirculating system, a fluid is transported from a fluid source to an ozone contacting device and then discharged as a sanitizing ozonated fluid. Since an ozone generator, which provides ozone to the ozone contacting device, yields better ozone concentration output from dry and/or oxygen enriched air, it may be beneficial to use a cartridge according to the present application to dry and/or remove nitrogen from the air used by the ozone generator.

[0176] Fig. **10** is a back perspective view of a removable air dryer cartridge **430** installed in a base unit **440** of a water ozonation device. The removable air dryer cartridge **430** is a particular example of the removable cartridge **408** having an air dryer and no water filter, and also having features specific to its use and interconnection with a base unit.

[0177] In the preceding description, for purposes of explanation, numerous details are set forth in order to provide a thorough understanding of the examples described. However, it will be apparent to one skilled in the art that these specific details are not required in order to practice the described examples.

[0178] Examples described herein can be represented as a software product stored in a machine-readable medium (also referred to as a computer-readable medium, a processor-readable medium, or a computer usable medium having a computer-readable program code embodied therein). The machine-readable medium can be any suitable tangible medium, including magnetic, optical, or electrical storage medium including a diskette, compact disk read only memory (CD-ROM), memory device (volatile or non-volatile), or similar storage mechanism. The machine-readable medium can contain various sets of instructions, code sequences, configuration information, or other data, which, when executed, cause a processor to perform steps in a method as described herein. Those of ordinary skill in the art will appreciate that other instructions and operations necessary to implement the described examples can also be stored on the machine-readable medium. Software running from the machine-readable medium can interface with circuitry to perform the described tasks.

[0179] The above-described descriptions are intended to be examples only. Alterations, modifications and variations can be effected to the particular examples by those of skill in the art without departing from the scope of the application.

Claims

1. A system for providing an ozonated liquid, the system comprising:

a tank-less ozonation flow path having a liquid inlet (12) and a liquid outlet (22), the flow path further comprising:

a liquid-gas mixer (14), in fluid communication with the liquid inlet, to mix the accepted liquid with gaseous ozone to produce a gaseous liquid comprising bubbles of undissolved gaseous ozone and an ozonated liquid; and

a gas-liquid separator (18), in fluid communication with the liquid-gas mixer, to separate the gaseous liquid into a degassed ozonated liquid comprising dissolved ozone, and into a separated gaseous ozone;

the liquid inlet (12) arranged to continuously accept a substantially unozonated liquid into the ozonation flow path at a desired flow rate; the liquid outlet (22) being in fluid communication

with the liquid inlet (12) and arranged to dispense the ozonated liquid out of the system at the desired flow rate;

the tank-less ozonation flow path adapted to ozonate the accepted liquid, producing the ozonated liquid to be dispensed out of the system, the accepted liquid having a fluid residence time in the ozonation flow path of less than 5 minutes prior to dispensing as the ozonated liquid;

characterised in that the gas-liquid separator (18) comprises:

a tubular member (122) having a side wall, and top and bottom end walls, the tubular member (122) having an upper portion (128) and a lower portion (120);

a gaseous liquid inlet (110) for entry of the gaseous liquid, the inlet (110) located in the lower portion (120) of the tubular member (122) and arranged to create a vortex of the gaseous liquid in the gas-liquid separator (18);

a gas outlet (144) located in the upper portion (128) of the tubular member (122), the gas outlet arranged to vent the separated gas out of the gas-liquid separator (18);

an annular separating baffle (130) positioned in the lower portion (120) of the tubular member (122) and secured to the side wall of the tubular member (122), the annular separating baffle (130) arranged to direct the flow of the degassed liquid towards a liquid outlet (132) and to direct the separated gas away from the liquid outlet (132), the annular separating baffle (130) and the side wall defining an annular degassed liquid region (136) therebetween which is open at both top and bottom ends, the degassed liquid flowable between the top and bottom ends; and

the liquid outlet (132) for egress of the degassed liquid from the annular degassed liquid region.

2. The system according to claim 1, wherein the liquid is accepted at an accepted pressure less than 758 kPa (110 psi) and the ozonated liquid is dispensed at a dispensing pressure which is directly dependent on the accepted pressure.
3. The system according to claim 2, wherein the accepted pressure is between about 138 kPa (20 psi) and about 689 kPa (100 psi) and the dispensing pressure is between about 138 kPa (20 psi) and about 689 kPa (100 psi).
4. The system according to claim 1, wherein the fluid residence time in the system is less than 1 minute.

5. The system according to claim 1, wherein the liquid-gas mixer (14) comprises the liquid inlet (12) and the fluid residence time is measured between the liquid-gas mixer (14) and the liquid outlet (22). 5
6. The system according to claim 1, wherein the fluid residence time between the liquid-gas mixer (14) and the gas-liquid separator (18) is between about 0.01 and 0.1 seconds. 10
7. The system according to claim 1, wherein the annular separating baffle (130) is positioned in line with the liquid outlet (132). 15
8. The system according to claim 1, wherein the gaseous liquid inlet (110) is positioned substantially tangential to the side wall of the tubular member (122). 20
9. The system according to claim 1, wherein the liquid outlet (132) is an annular aperture defined by the side wall. 25
10. The system according to claim 1, wherein the liquid outlet (132) is positioned substantially tangential to the side wall of the tubular member (122). 25

Patentansprüche

1. Ein System zum Bereitstellen einer ozonisierten Flüssigkeit, wobei das System Folgendes umfasst: 30
- einen behälterlosen Ozonisierungsflussweg, der einen Flüssigkeitseinlass (12) und einen Flüssigkeitsauslass (22) aufweist, wobei der Flussweg ferner Folgendes umfasst: 35
- einen Flüssigkeit-Gas-Mischer (14), der in Fluidverbindung mit dem Flüssigkeitseinlass steht, um die angenommene Flüssigkeit mit gasförmigem Ozon zu vermischen, um eine gasförmige Flüssigkeit zu erzeugen, die Blasen aus ungelöstem gasförmigem Ozon und eine ozonisierte Flüssigkeit umfasst, und 40
- einen Gas-Flüssigkeit-Abscheider (18), der in Fluidverbindung mit dem Flüssigkeit-Gas-Mischer steht, um die gasförmige Flüssigkeit in eine entgaste ozonisierte Flüssigkeit, die gelöstes Ozon umfasst, und in ein abgeschiedenes gasförmiges Ozon zu trennen, 45
- wobei der Flüssigkeitseinlass (12) so angeordnet ist, dass er kontinuierlich eine im Wesentlichen nicht ozonisierte Flüssigkeit mit einer gewünschten Fließgeschwindigkeit in den Ozonisierungsflussweg aufnimmt, 50
- 55

wobei der Flüssigkeitsauslass (22) in Fluidverbindung mit dem Flüssigkeitseinlass (12) steht und so angeordnet ist, dass die ozonisierte Flüssigkeit mit der gewünschten Fließgeschwindigkeit aus dem System abgegeben wird, wobei der behälterlose Ozonisierungsflussweg so angepasst ist, dass er die angenommene Flüssigkeit ozonisiert, wodurch die ozonisierte Flüssigkeit erzeugt wird, die aus dem System abgegeben werden soll, wobei die angenommene Flüssigkeit eine Fluidverweilzeit von weniger als 5 Minuten in dem Ozonisierungsflussweg hat, bevor sie als ozonisierte Flüssigkeit abgegeben wird, **dadurch gekennzeichnet, dass** der Gas-Flüssigkeit-Abscheider (18) Folgendes umfasst:

ein rohrförmiges Element (122) mit einer Seitenwand und oberen und unteren Endwänden, wobei das rohrförmige Element (122) einen oberen Abschnitt (128) und einen unteren Abschnitt (120) aufweist, einen gasförmigen Flüssigkeitseinlass (110) zum Eintreten der gasförmigen Flüssigkeit, wobei der Einlass (110) im unteren Abschnitt (120) des rohrförmigen Elements (122) befindlich ist und angeordnet ist, um einen Wirbel der gasförmigen Flüssigkeit in dem Gas-Flüssigkeit-Abscheider (18) zu erzeugen, einen Gasauslass (144), der im oberen Abschnitt (128) des rohrförmigen Elements (122) befindlich ist, wobei der Gasauslass so angeordnet ist, dass er das abgetrennte Gas aus dem Gas-Flüssigkeit-Abscheider (18) entlüftet, ein ringförmiges Umlenkblech (130), das in dem unteren Abschnitt (120) des rohrförmigen Elements (122) angeordnet und an der Seitenwand des rohrförmigen Elements (122) befestigt ist, wobei das ringförmige Umlenkblech (130) so angeordnet ist, dass es den Strom der entgasten Flüssigkeit zu einem Flüssigkeitsauslass (132) leitet und das abgetrennte Gas von dem Flüssigkeitsauslass (132) wegleitet, wobei das ringförmige Umlenkblech (130) und die Seitenwand einen ringförmigen entgasten Flüssigkeitsbereich (136) dazwischen definieren, der sowohl am oberen als auch am unteren Ende offen ist, wobei die entgaste Flüssigkeit zwischen dem oberen und dem unteren Ende fließfähig ist, und den Flüssigkeitsauslass (132) zum Austritt der entgasten Flüssigkeit aus dem ringförmigen entgasten Flüssigkeitsbereich.

2. System nach Anspruch 1, wobei die Flüssigkeit bei

- einem akzeptierten Druck von weniger als 758 kPa (110 psi) angenommen wird und die ozonisierte Flüssigkeit bei einem Abgabedruck abgegeben wird, der direkt vom akzeptierten Druck abhängig ist.
- 5
3. System nach Anspruch 2, wobei der akzeptierte Druck zwischen etwa 138 kPa (20 psi) und etwa 689 kPa (100 psi) liegt und der Abgabedruck zwischen etwa 138 kPa (20 psi) und etwa 689 kPa (100 psi) liegt.
- 10
4. System nach Anspruch 1, wobei die Fluidverweilzeit im System weniger als 1 Minute beträgt.
- 15
5. System nach Anspruch 1, wobei der Flüssigkeit-Gas-Mischer (14) den Flüssigkeitseinlass (12) umfasst und die Fluidverweilzeit zwischen dem Flüssigkeit-Gas-Mischer (14) und dem Flüssigkeitsauslass (22) gemessen wird.
- 20
6. System nach Anspruch 1, wobei die Fluidverweilzeit zwischen dem Flüssigkeit-Gas-Mischer (14) und dem Gas-Flüssigkeit-Abscheider (18) zwischen etwa 0,01 und 0,1 Sekunden liegt.
- 25
7. System nach Anspruch 1, wobei das ringförmige Umlenklech (130) in einer Linie mit dem Flüssigkeitsauslass (132) angeordnet ist.
- 30
8. System nach Anspruch 1, wobei der gasförmige Flüssigkeitseinlass (110) im Wesentlichen tangential zur Seitenwand des rohrförmigen Elements (122) angeordnet ist.
- 35
9. System nach Anspruch 1, wobei der Flüssigkeitsauslass (132) eine durch die Seitenwand definierte ringförmige Öffnung ist.
- 40
10. System nach Anspruch 1, wobei der Flüssigkeitsauslass (132) im Wesentlichen tangential zur Seitenwand des rohrförmigen Elements (122) angeordnet ist.

Revendications

1. Système pour la fourniture d'un liquide ozoné, le système comprenant :

un trajet de circulation d'ozonation sans cuve possédant un entrée de liquide (12) et une sortie de liquide (22), le trajet de circulation comprenant en outre :

un mélangeur liquide-gaz (14) en communication fluïdique avec l'entrée de liquide pour mélanger le liquide admis avec de l'ozone gazeux afin de produire un liquide

gazeux comprenant des bulles d'ozone gazeux non dissous et un liquide ozoné ; et un séparateur gaz-liquide (18) en communication fluïdique avec le mélangeur liquide-gaz pour séparer le liquide gazeux en liquide ozoné dégazé comprenant de l'ozone dissous, et un ozone gazeux distinct ;

l'entrée de liquide (12) agencée pour admettre en continu un liquide substantiellement désazoné dans le trajet de circulation d'ozonation à un débit désiré ; la sortie de liquide (22) étant en communication fluïdique avec l'entrée de liquide (12), et agencée pour distribuer le liquide ozoné hors du système au débit désiré ; le trajet de circulation d'ozonation sans cuve étant adapté pour ozoner le liquide admis, en produisant le liquide ozoné à distribuer hors du système, le liquide admis ayant un temps de séjour du fluïde dans le trajet de circulation d'ozonation inférieur à 5 minutes préalablement à la distribution en tant que liquide ozoné ;

caractérisé en ce que le séparateur gaz-liquide (18) comprend :

un élément tubulaire (122) possédant une paroi latérale, et des parois d'extrémité supérieure et inférieure, l'élément tubulaire (122) possédant une partie supérieure (128) et une partie inférieure (120) ; une entrée de liquide gazeux (110) pour l'entrée du liquide gazeux, l'entrée (110) étant située dans la partie inférieure (120) de l'élément tubulaire (122), et agencée de façon à créer un tourbillon de liquide gazeux dans le séparateur gaz-liquide (18) ; une sortie de gaz (144) située dans la partie supérieure (128) de l'élément tubulaire (122), la sortie de gaz étant agencée pour évacuer le gaz séparé hors du séparateur gaz-liquide (18) ; une chicane de séparation annulaire (130) positionnée dans la partie inférieure (120) de l'élément tubulaire (122), et fixée sur la paroi latérale de l'élément tubulaire (122), la chicane de séparation annulaire (130) étant agencée pour diriger le débit de liquide dégazé vers une sortie de liquide (132) et diriger le gaz séparé dans la direction opposée à la sortie de liquide (132), la chicane de séparation annulaire (130) et la paroi latérale définissant une zone annulaire de liquide dégazé (136) entre elles, ouverte aux extrémités supérieure et inférieure, le liquide dégazé pouvant s'écouler entre les extrémités supérieure et inférieure ; et la sortie de liquide (132) pour l'évacuation

du liquide dégazé par la zone annulaire de liquide dégazé.

2. Système selon la revendication 1, l'admission du liquide s'effectuant à une pression d'admission inférieure à 758 kPa (110 psi), et le liquide ozoné étant distribué à une pression de distribution directement tributaire de la pression d'admission. 5
3. Système selon la revendication 2, la pression d'admission étant comprise entre environ 138 kPa (20 psi) et environ 689 kPa (100 psi), et la pression de distribution entre environ 138 kPa (20 psi) et environ 689 kPa (100 psi). 10
15
4. Système selon la revendication 1, le temps de séjour du fluide dans le système étant inférieur à 1 minute.
5. Système selon la revendication 1, le mélangeur liquide-gaz (14) comprenant l'entrée de liquide (12) et le temps de séjour du fluide étant mesuré entre le mélangeur liquide-gaz (14) et la sortie de liquide (22). 20
6. Système selon la revendication 1, le temps de séjour du fluide entre le mélangeur liquide-gaz (14) et le séparateur gaz-liquide (18) étant compris entre environ 0,01 and 0,1 seconde. 25
7. Système selon la revendication 1, la chicane de séparation annulaire (130) étant alignée avec la sortie de liquide (132). 30
8. Système selon la revendication 1, l'entrée de liquide gazeux (110) étant positionnée de façon substantiellement tangentielle à la paroi latérale de l'élément tubulaire (122). 35
9. Système selon la revendication 1, la sortie de liquide (132) étant une ouverture annulaire définie par la paroi latérale. 40
10. Système selon la revendication 1, la sortie de liquide (132) étant positionnée de façon substantiellement tangentielle à la paroi latérale de l'élément tubulaire (122). 45

50

55

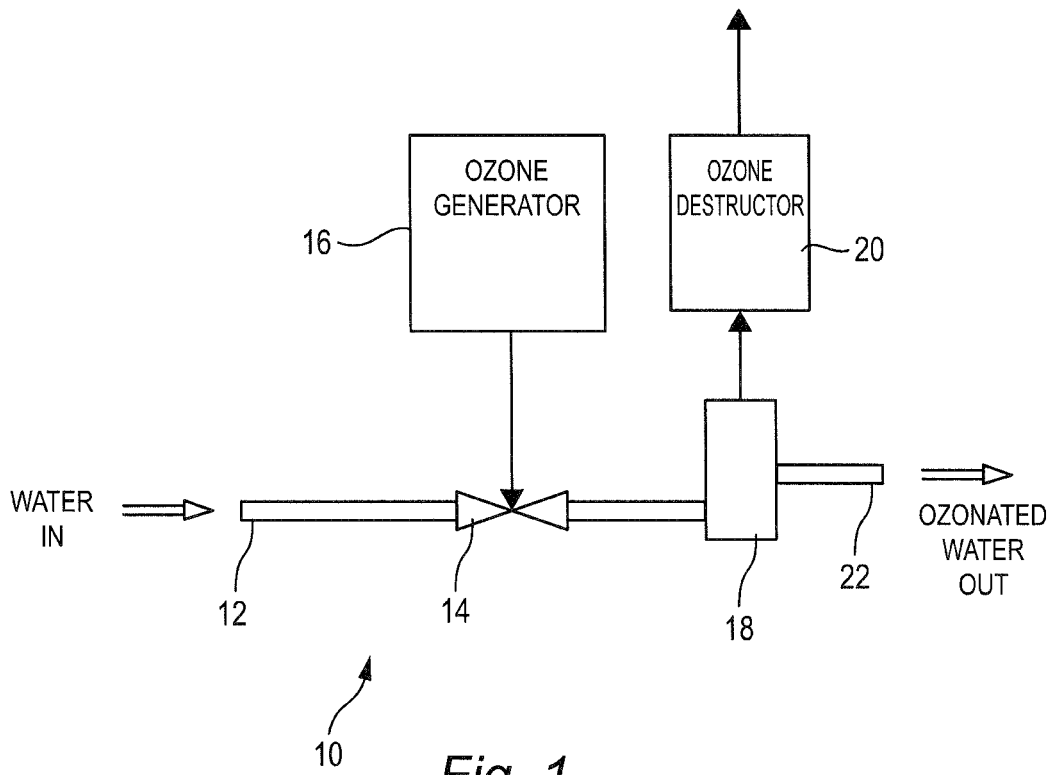

Fig. 1

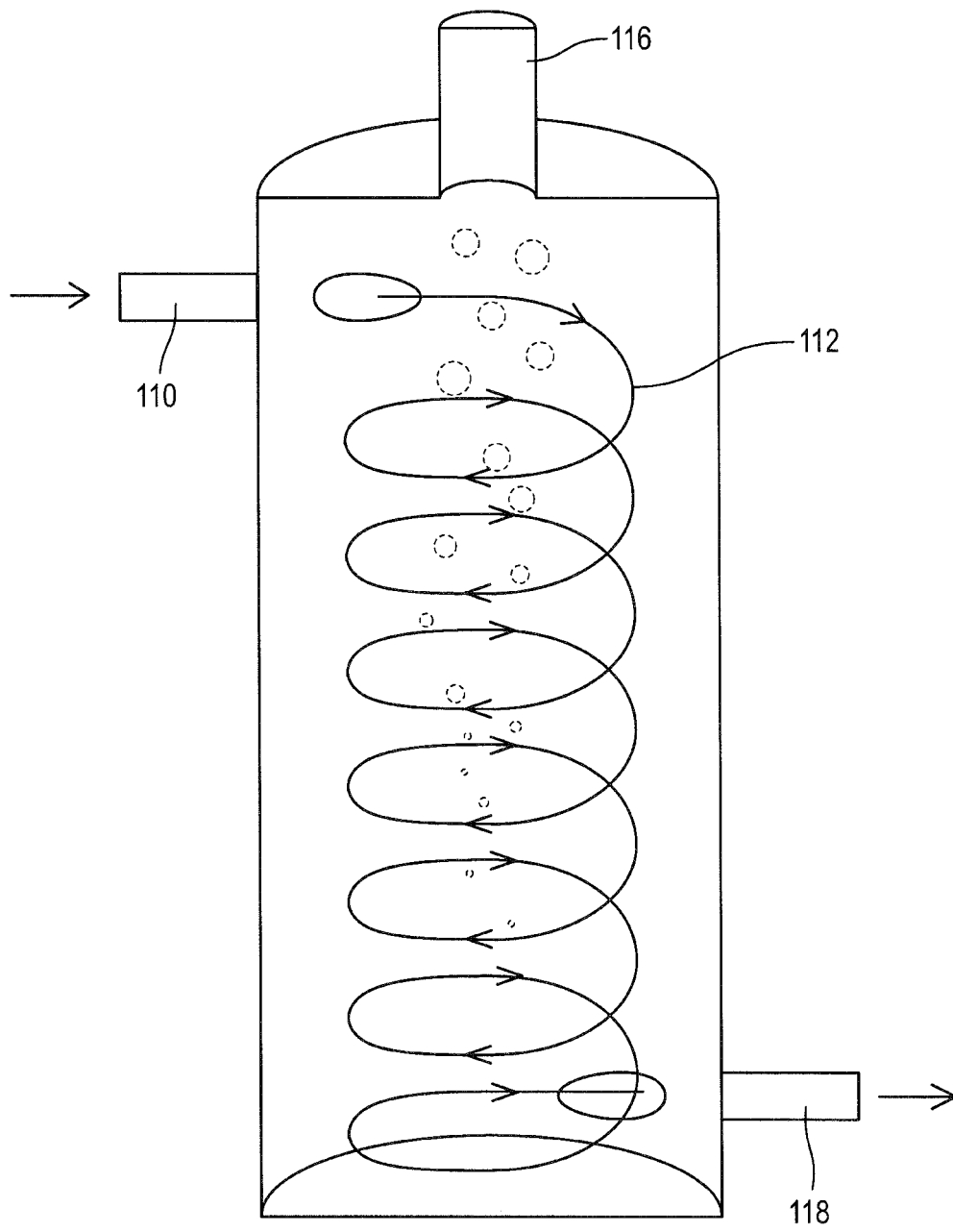

Fig. 2
Prior Art

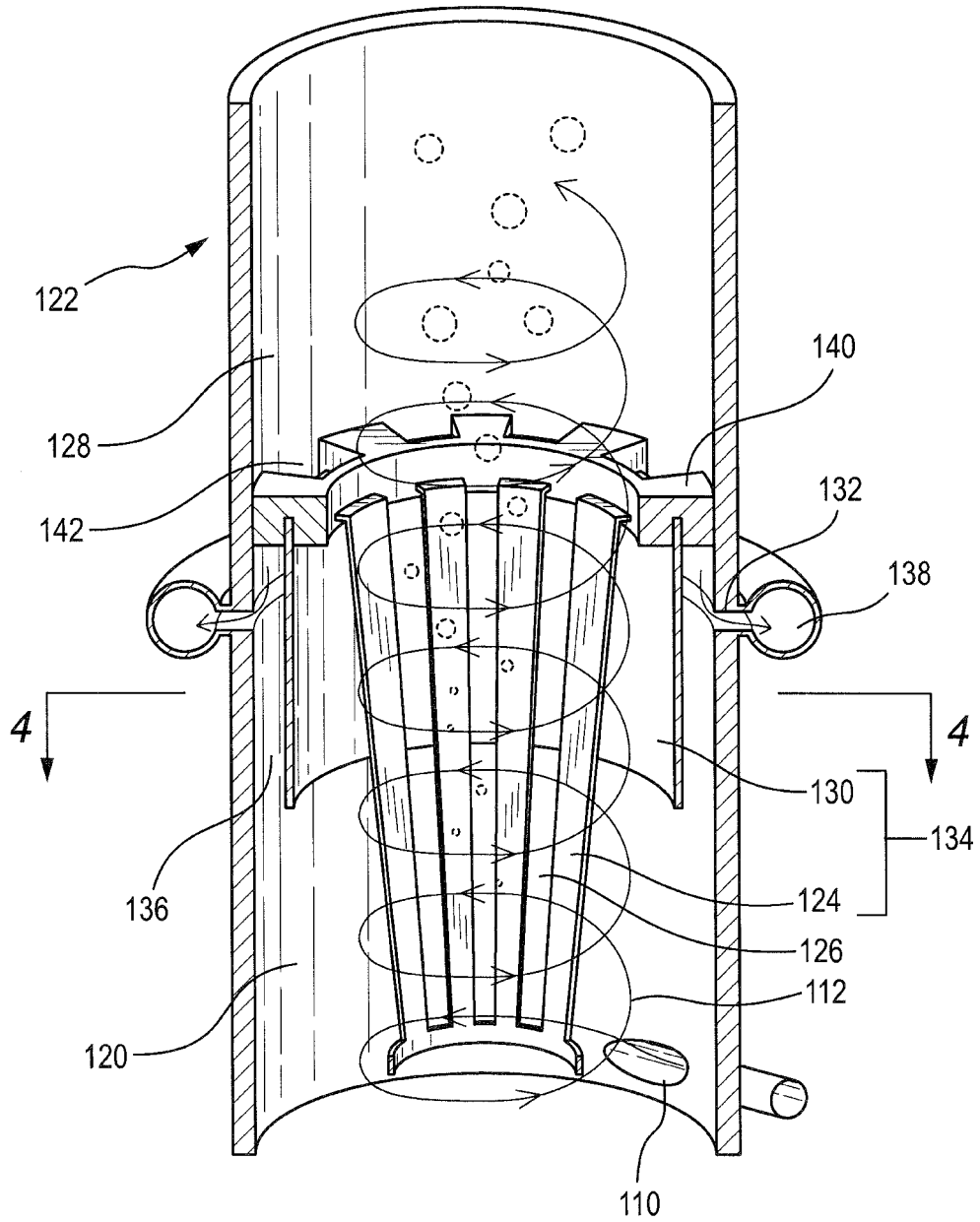

Fig. 3

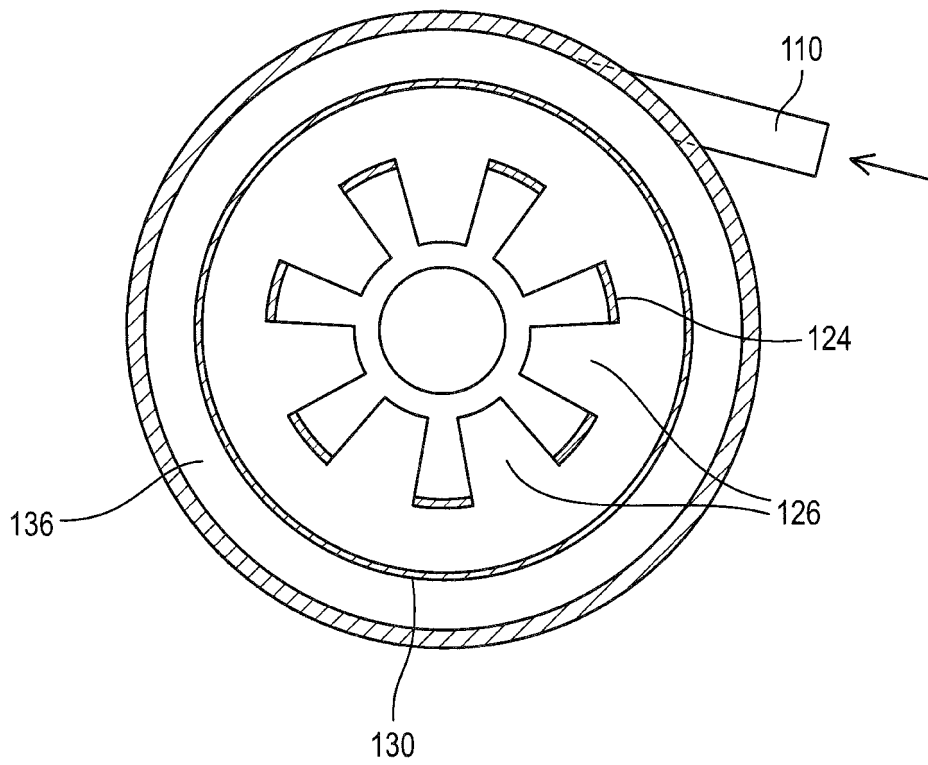

Fig. 4

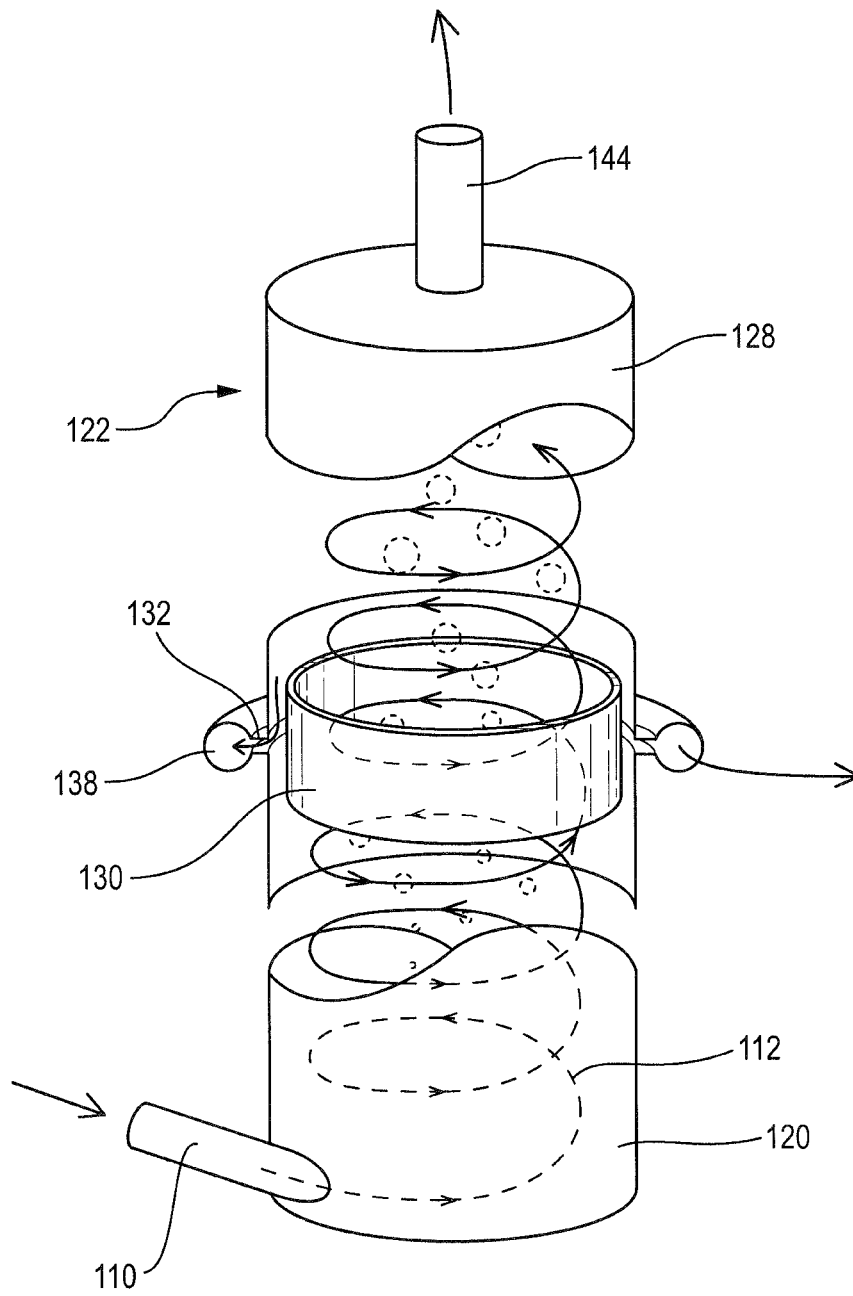

Fig. 5

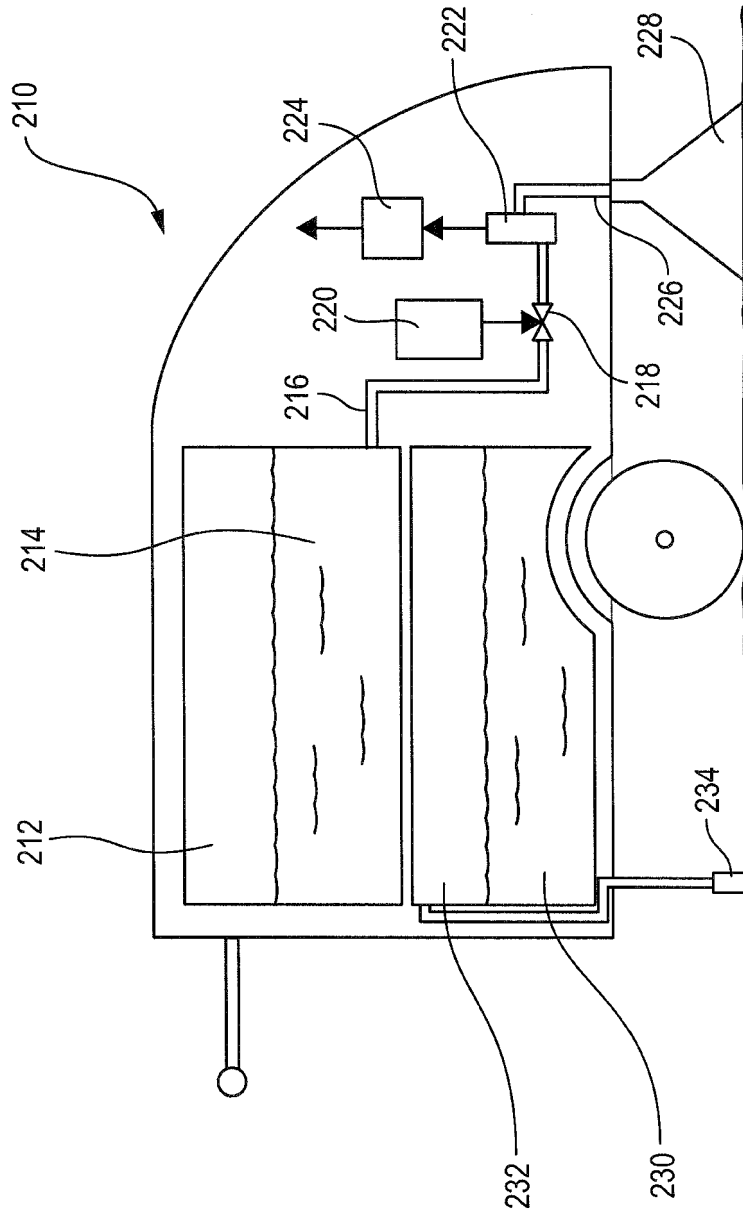

Fig. 6

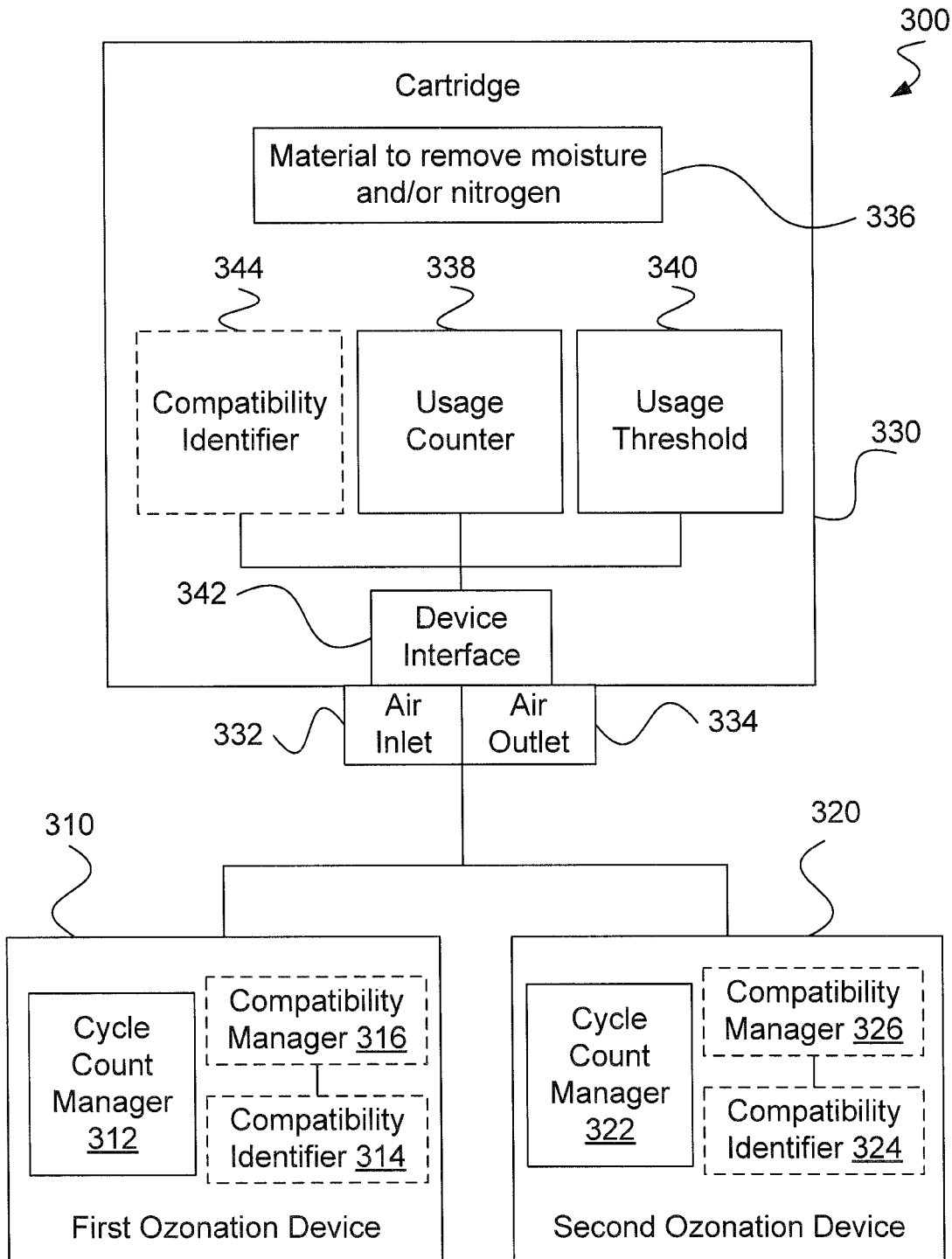

FIG. 7

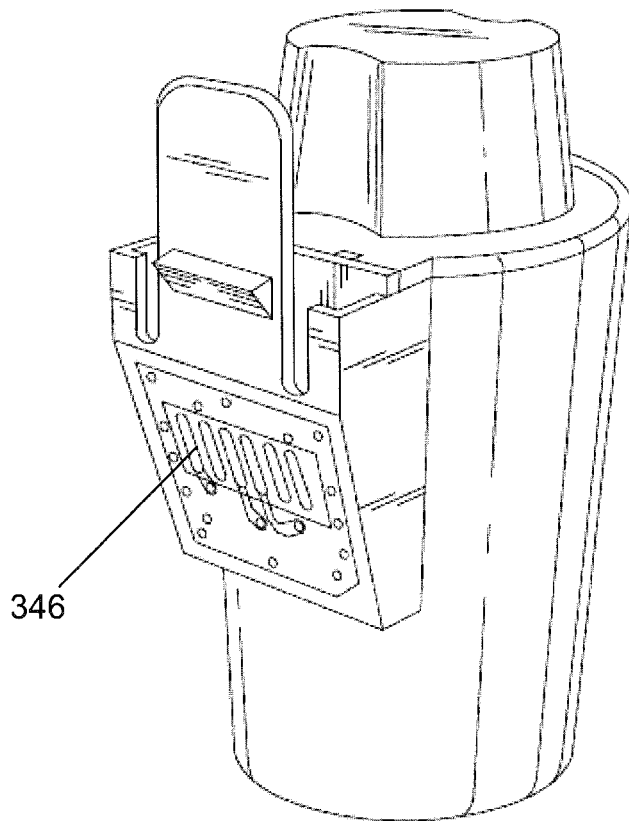

FIG. 8A

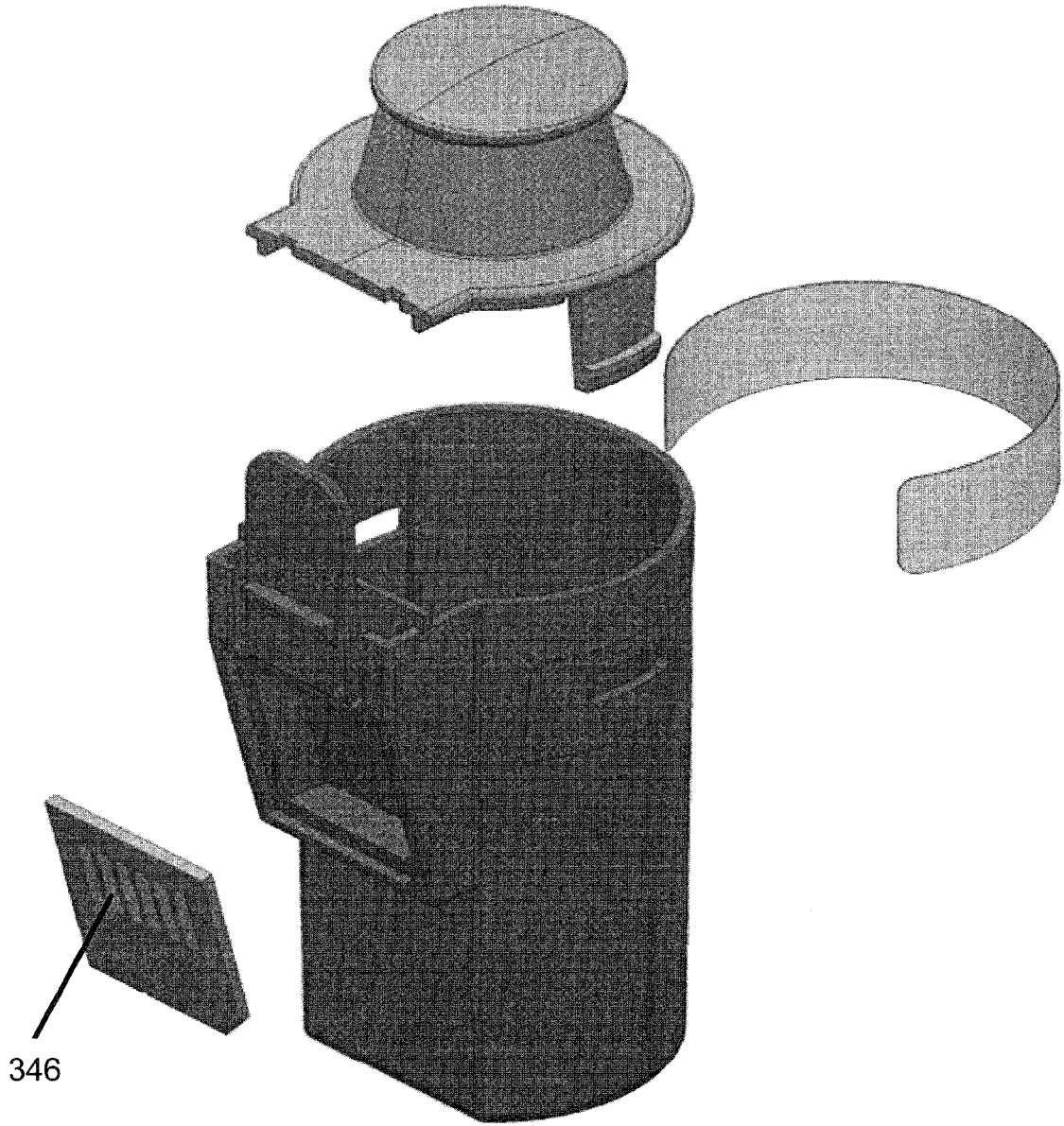

FIG. 8B

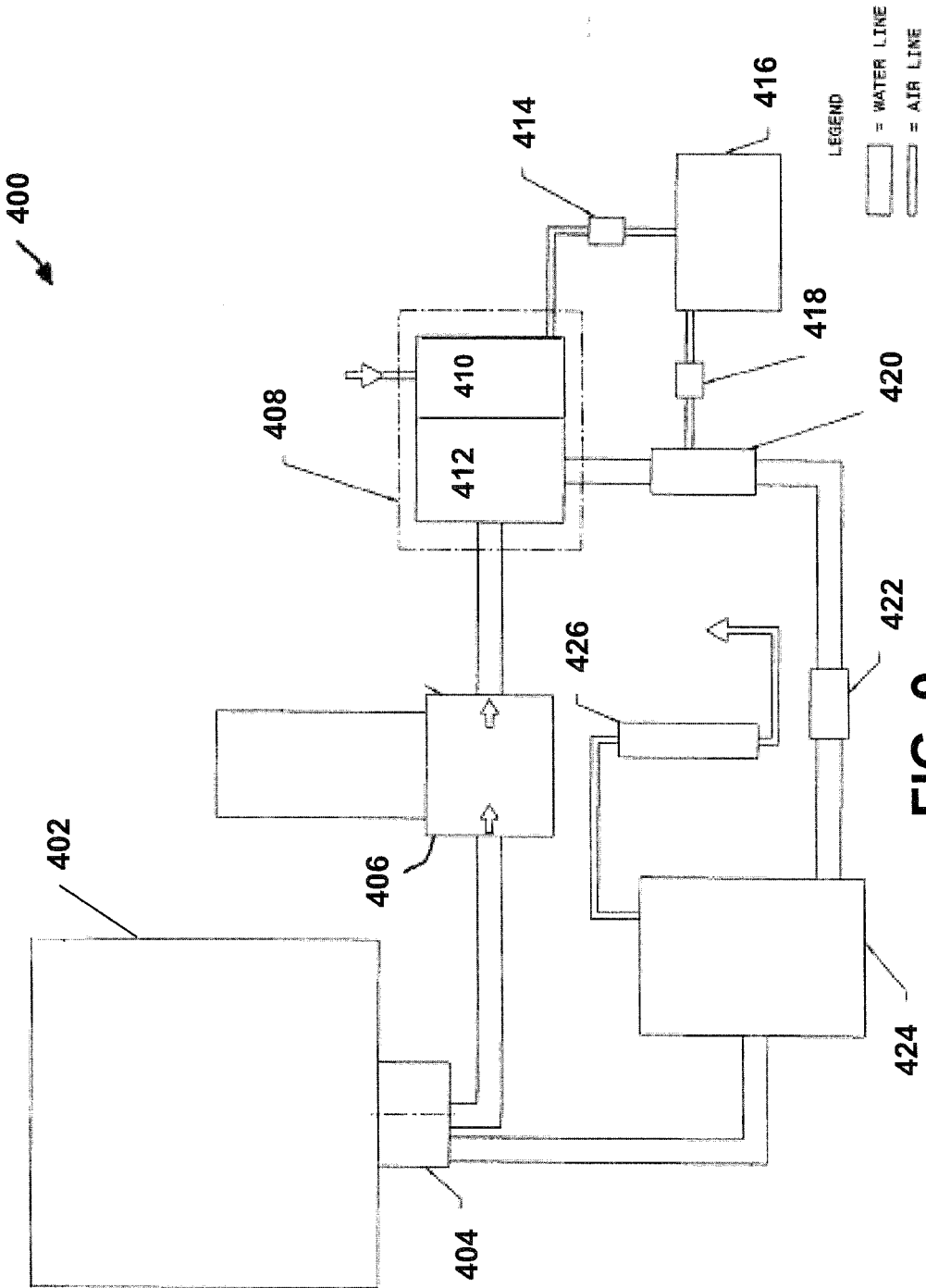

FIG. 9

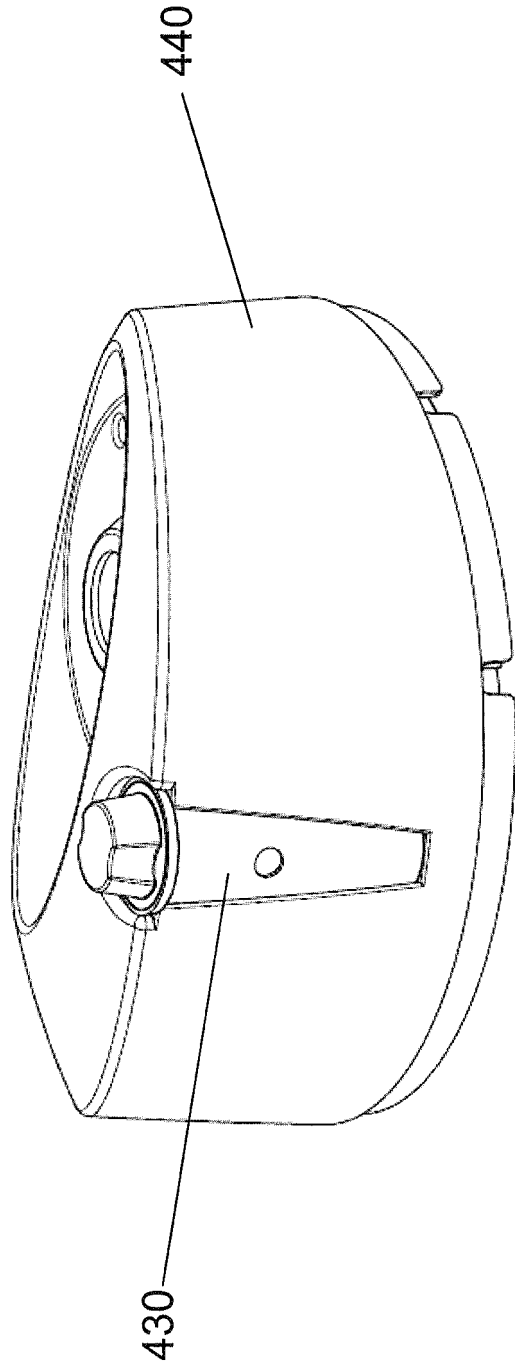

FIG. 10

REFERENCES CITED IN THE DESCRIPTION

This list of references cited by the applicant is for the reader's convenience only. It does not form part of the European patent document. Even though great care has been taken in compiling the references, errors or omissions cannot be excluded and the EPO disclaims all liability in this regard.

Patent documents cited in the description

- US 20080190825 A1 [0016] [0126]
- US 4427426 A [0018]
- WO 2009117141 A1 [0018]
- US 6053967 A [0099]
- US 6964739 B [0124]
- WO 2004113232 A [0163]