



(51) International Patent Classification:

A61J 3/00 (2006.01) C12N 13/00 (2006.01)
A61K 35/12 (2015.01) C12M 1/00 (2006.01)
A61K 35/14 (2015.01)

LEIDEL, Chris; 380 Main Street, Wilbraham, Massachusetts 01095 (US). MASI, Louis; 380 Main Street, Wilbraham, Massachusetts 01095 (US). GHOSHAL, Goutam; 380 Main Street, Wilbraham, Massachusetts 01095 (US).

(21) International Application Number:

PCT/US2017/030903

(74) Agent: KLEIN, Richard M.; Fay Sharpe LLP, 1228 Euclid Avenue, 5th Floor, Cleveland, Ohio 44115 (US).

(22) International Filing Date:

03 May 2017 (03.05.2017)

(81) Designated States (unless otherwise indicated, for every kind of national protection available):

AE, AG, AL, AM, AO, AT, AU, AZ, BA, BB, BG, BH, BN, BR, BW, BY, BZ, CA, CH, CL, CN, CO, CR, CU, CZ, DE, DJ, DK, DM, DO, DZ, EC, EE, EG, ES, FI, GB, GD, GE, GH, GM, GT, HN, HR, HU, ID, IL, IN, IR, IS, JP, KE, KG, KH, KN, KP, KR, KW, KZ, LA, LC, LK, LR, LS, LU, LY, MA, MD, ME, MG, MK, MN, MW, MX, MY, MZ, NA, NG, NI, NO, NZ, OM, PA, PE, PG, PH, PL, PT, QA, RO, RS, RU, RW, SA, SC, SD, SE, SG, SK, SL, SM, ST, SV, SY, TH, TJ, TM, TN, TR, TT, TZ, UA, UG, US, UZ, VC, VN, ZA, ZM, ZW.

(25) Filing Language:

English

(26) Publication Language:

English

(30) Priority Data:

62/330,947 03 May 2016 (03.05.2016) US
62/359,182 06 July 2016 (06.07.2016) US
62/374,910 15 August 2016 (15.08.2016) US

(71) Applicant: FLODESIGN SONICS, INC. [US/US]; 380 Main Street, Wilbraham, Massachusetts 01095 (US).

(72) Inventors: LIPKENS, Bart; 380 Main Street, Wilbraham, Massachusetts 01095 (US). PRESZ, Walter M. Jr; 380 Main Street, Wilbraham, Massachusetts 01095 (US). DUTRA, Brian; 380 Main Street, Wilbraham, Massachusetts 01095 (US). GILMANSHIN, Rudolf; 380 Main Street, Wilbraham, Massachusetts 01095 (US). DIONNE, Jason; 380 Main Street, Wilbraham, Massachusetts 01095 (US).

(84) Designated States (unless otherwise indicated, for every kind of regional protection available):

ARIPO (BW, GH, GM, KE, LR, LS, MW, MZ, NA, RW, SD, SL, ST, SZ, TZ, UG, ZM, ZW), Eurasian (AM, AZ, BY, KG, KZ, RU, TJ, TM), European (AL, AT, BE, BG, CH, CY, CZ, DE, DK, EE, ES, FI, FR, GB, GR, HR, HU, IE, IS, IT, LT, LU, LV, MC, MK, MT, NL, NO, PL, PT, RO, RS, SE, SI, SK, SM,

(54) Title: THERAPEUTIC CELL WASHING, CONCENTRATION, AND SEPARATION UTILIZING ACOUSTOPHORESIS

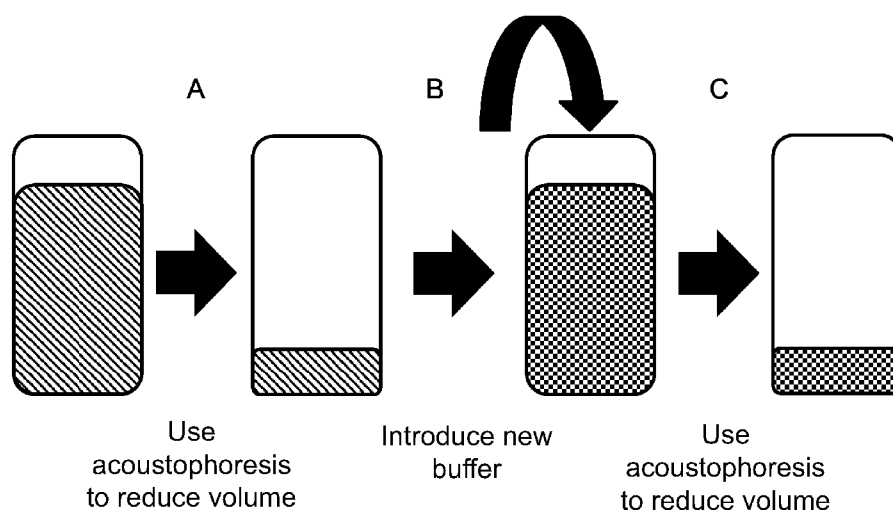

FIG. 2

(57) Abstract: Multi-stage acoustophoretic devices for continuously separating a second fluid or a particulate from a host fluid are disclosed. Methods of operating the multi-stage acoustophoretic devices are also disclosed. The systems include multiple acoustophoretic devices fluidly connected to one another in series, each acoustophoretic device comprising a flow chamber, an ultrasonic transducer capable of creating a multi-dimensional acoustic standing wave, and a reflector. The systems can further include pumps and flowmeters.



TR), OAPI (BF, BJ, CF, CG, CI, CM, GA, GN, GQ, GW,
KM, ML, MR, NE, SN, TD, TG).

Published:

- *with international search report (Art. 21(3))*
- *before the expiration of the time limit for amending the claims and to be republished in the event of receipt of amendments (Rule 48.2(h))*

THERAPEUTIC CELL WASHING, CONCENTRATION, AND SEPARATION UTILIZING ACOUSTOPHORESIS

CROSS-REFERENCE TO RELATED APPLICATIONS

[0001] This application claims priority to U.S. Provisional Patent Application Serial No. 62/330,947, filed on May 3, 2016, and to U.S. Provisional Patent Application Serial No. 62/359,182, filed on July 6, 2016, and to U.S. Provisional Patent Application Serial No. 62/374,910, filed on August 15, 2016. The disclosures of these applications are hereby fully incorporated herein by reference in their entirety.

BACKGROUND

[0002] Concentrating therapeutic cells and transferring them from one solution into another (usually referred to as washing) are two processes involved at multiple stages of production and use of the cells. The washing and separation of materials in cellular processing is an important part of the overall efficacy of the cell therapy of choice. In particular, therapeutic cells may originally be suspended in a growth serum or in preservative materials like dimethyl sulfoxide (DMSO). Separating the cells from these fluids so the cells can be further processed is important in the overall therapeutic process of using such cellular materials. In one example, the cells are typically recovered from a bioreactor, concentrated, and transferred from culture media into an electroporation buffer prior to transduction, such as in manufacturing CAR-T cells. After expansion of cells at the final manufacturing step, they are concentrated and transferred into an appropriate solvent depending on the desired application.

[0003] Therapeutic cells are stored in specialized media to prolong the viability of these cells either through refrigeration and or freezing processes. Such specialized media may not be compatible when the therapeutic cells are introduced into a patient. It may thus be helpful to both wash and concentrate the therapeutic cells in a buffer or wash media that is biocompatible with both the therapeutic cells and with the patient. These washing and concentration processes conventionally involve the use of centrifugation and physical filtration. The washing step may be repeated a number of times. For example, the specialized media (which can be pyrogenic or otherwise harmful) may be fully

removed with multiple wash steps, and the cells may be suspended in a new buffer or wash solution. During this washing process, many of the cells are degraded or destroyed through the centrifugation and physical filtration processes. Moreover, the filtration process can be rather inefficient and may entail a non-sterile intrusion into the environment for batch processing, whereby the cell culture is exposed to possible pathogens or outside cellular influences that would be harmful to the target cell culture. Further yet, with these physical filtration processes, biological waste is generated through the use of multiple physical filters which may incur additional steps for proper disposal. The cost and timeliness of this process is also not conducive to a fast or low-cost process of preparing the cells for introduction to the patient.

BRIEF SUMMARY

[0004] The present disclosure provides methods and systems for replacing or augmenting conventional centrifugation and physical filtration processes along with the multiple washing steps with a simpler, lower cost, and more friendly process for particles such as therapeutic cells. The methods / processes can be performed in a sterile environment and in a continuous form.

[0005] Disclosed herein are methods of washing particles, which comprise feeding an initial mixture of a first media and the particles through a flow chamber of an acoustophoretic device. For example, the first media may contain preservatives such as dimethyl sulfoxide (DMSO) which are undesirable for future applications / uses of the particles, such as cells. The acoustophoretic device also comprises at least one ultrasonic transducer that includes a piezoelectric material that is configured to be driven to create a multi-dimensional acoustic standing wave in the flow chamber. The at least one ultrasonic transducer is driven to create a multi-dimensional acoustic standing wave in the flow chamber, such that at least a portion of the particles are trapped in the multi-dimensional acoustic standing wave. The trapped particles are subsequently mixed with a second media to wash the trapped particles (e.g. remove the first media from the particles).

[0006] In some embodiments, the initial mixture is run through the flow chamber to obtain an intermediate mixture of the particles in a reduced volume of the first media. The

intermediate mixture is then collected, and mixed together with the second media to form a secondary mixture. The secondary mixture is then fed through the flow chamber to obtain a final mixture of particles in a reduced volume of the second media.

[0007] In other embodiments, the second media is fed into the flow chamber after the initial mixture is fed through the flow chamber. Here, the second media displaces the first media, or gradually replaces the first media.

[0008] In still other embodiments, the acoustophoretic device further comprises a collector located below the at least one ultrasonic transducer so that as the trapped particles form clusters and grow to a critical size and subsequently fall out of the multi-dimensional acoustic standing wave, the clusters fall into the collector. The collector leads to a collection container that contains the second media, mixing the clusters of particles together with the second media.

[0009] The second media can be a biocompatible wash or a buffer solution.

[0010] The particles may be cells. The cells may be Chinese hamster ovary (CHO) cells, NS0 hybridoma cells, baby hamster kidney (BHK) cells, human cells, regulatory T-cells, Jurkat T-cells, CAR-T cells, B cells, or NK cells, peripheral blood mononuclear cells (PBMCs), algae, plant cells, bacteria, or viruses. The cells may be attached to microcarriers.

[0011] Sometimes, the piezoelectric material of the at least one ultrasonic transducer is in the form of a piezoelectric array formed from a plurality of piezoelectric elements. Each piezoelectric element can be physically separated from surrounding piezoelectric elements by a potting material. The piezoelectric array can be present on a single crystal, with one or more channels separating the piezoelectric elements from each other. Each piezoelectric element can be individually connected to its own pair of electrodes. The piezoelectric elements can be operated in phase with each other, or operated out of phase with each other. The acoustophoretic device may further comprise a cooling unit for cooling the at least one ultrasonic transducer.

[0012] Also disclosed are methods of separating microcarriers from cells, comprising feeding an initial mixture of a first media and microcarriers with attached cells thereon through a flow chamber of an acoustophoretic device. Again, the acoustophoretic device also comprises at least one ultrasonic transducer including a piezoelectric material that is

configured to be driven to create a multi-dimensional acoustic standing wave in the flow chamber. The at least one ultrasonic transducer is driven to create a multi-dimensional acoustic standing wave in the flow chamber, and to trap at least a portion of the microcarriers with attached cells in the multi-dimensional acoustic standing wave. The trapped microcarriers with attached cells are then washed by flowing a second media through the flow chamber to remove the first media. Next, a third media containing an enzyme is flowed through the flow chamber to separate the cells from the microcarriers.

[0013] In some examples, the microcarriers remain trapped in the multi-dimensional acoustic standing wave, and the cells are separated from the microcarriers and/or the fluid. Alternatively, the cells remain trapped in the multi-dimensional acoustic standing wave, and the microcarriers flow through the device. The mixture of the cells and the third media can then be recovered. The second media and the third media can be the same, or can be different. In particular embodiments, the enzyme is trypsin.

[0014] Also disclosed herein are culture bags, comprising: a sidewall that surrounds an internal volume, the internal volume including an upper portion and a lower portion; a fill port at an upper end of the culture bag in the upper portion; a drain port at a lower end of the culture bag in the lower portion; and a wash outlet located at a bottom end of the upper portion between the fill port and the drain port; wherein the upper portion may have a larger diameter than the lower portion.

[0015] The wash outlet may be connected to a wash inlet located in the lower portion of the culture bag. The lower portion may comprise from about 1% to about 5% of the internal volume.

[0016] Also disclosed are acoustophoretic systems that use the culture bag described above. The systems also include at least one ultrasonic transducer including a piezoelectric material that is configured to be driven to create a multi-dimensional acoustic standing wave in the culture bag; and means for moving the at least one ultrasonic transducer relative to the culture bag between the upper end and the lower end thereof.

[0017] The acoustophoretic system may further comprise a tank into which the culture bag can be placed. The means for moving the at least one ultrasonic transducer may be a conveyor system located outside of the tank.

[0018] The acoustophoretic system may further comprise means for sealing the culture bag between the upper portion and the lower portion thereof. For example, a heating bar could be used to melt two opposite sides of the culture bag together, separating the upper portion from the lower portion.

[0019] Also disclosed herein are acoustophoretic systems, comprising: an acoustophoretic device comprising a feed port, a drain port located below the feed port and configured to operate as both a wash inlet and a concentrate outlet, a wash outlet, and at least one ultrasonic transducer including a piezoelectric material that is configured to be driven to create a multi-dimensional acoustic standing wave; a feed line leading to the feed port of the acoustophoretic device; a waste line leading away from the waste outlet of the acoustophoretic device; and a wash line leading to the drain port of the acoustophoretic device; and a concentrate line leading away from the drain port of the acoustophoretic device. The various lines lead to containers that provide or receive various materials to / from the acoustophoretic device.

[0020] The acoustophoretic system can further comprise a valve to switch between the wash line and the concentrate line.

[0021] Alternatively, in the acoustophoretic system, the feed line and the wash line can pass through an inflow selector valve. The acoustophoretic system may further comprise a feed selector valve upstream of the inflow selector valve. The waste line and the concentrate line can also pass through an outflow selector valve.

[0022] These and other non-limiting characteristics are more particularly described below.

BRIEF DESCRIPTION OF THE DRAWINGS

[0023] The patent or application file contains at least one drawing executed in color. Copies of this patent or patent application publication with color drawing(s) will be provided by the Office upon request and payment of the necessary fee.

[0024] The following is a brief description of the drawings, which are presented for the purposes of illustrating the example embodiments disclosed herein and not for the purposes of limiting the same.

[0025] FIG. 1 illustrates an example acoustophoresis process using a transducer and reflector to create an acoustic standing wave for trapping particles and separating them from a fluid by enhanced gravitational settling.

[0026] FIG. 2 illustrates an example cell concentration and washing process (“diafiltration”) according to the present disclosure using acoustophoresis.

[0027] FIG. 3 illustrates another example cell concentration and washing process (push through) according to the present disclosure using acoustophoresis.

[0028] FIG. 4 shows six photographs that, from left to right and top to bottom, show the progression of cells being trapped in an acoustophoretic device before a second media mixture (dyed blue) is flowed into the device and gradually replaces the first media (dyed red).

[0029] FIG. 5 is a perspective view of an example acoustophoretic device according to the present disclosure.

[0030] FIG. 6 is a cross-sectional illustration of the acoustophoretic device of FIG. 5.

[0031] FIG. 7 is a graph showing the performance of the acoustophoretic device of FIG. 5. The x-axis is elapsed time (minutes) and runs from 0 to 40 in increments of 5. The left-side y-axis is permeate density reduction (%) and runs from 0 to 100 in increments of 10. The right-side y-axis is permeate cell density ($\times 10^6$ cells/mL) and runs from 0.00 to 2.00 in increments of 0.20. The uppermost solid line represents permeate reduction density (%). The lowermost solid line represents permeate cell density. The middle line running substantially horizontally across the page represents feed cell density for reference purposes.

[0032] FIG. 8 is a conventional single-piece monolithic piezoelectric material used in an ultrasonic transducer.

[0033] FIG. 9 is an example rectangular piezoelectric array having 16 piezoelectric elements used in the transducers of the present disclosure.

[0034] FIG. 10 is another example rectangular piezoelectric array having 25 piezoelectric elements used in the transducers of the present disclosure.

[0035] FIG. 11 is a diagram illustrating a piezoelectric material having 16 piezoelectric elements operated in out-of-phase modes. Dark elements indicate a 0° phase angle and light elements indicate a 180° phase angle.

[0036] FIG. 12 illustrates a kerfed piezoelectric material (top) versus a transducer array that has piezoelectric elements joined together by a potting material (bottom).

[0037] FIG. 13 is a graph showing the performance of an acoustophoretic device according to the present disclosure having a 16-element piezoelectric array, with the elements operated in-phase with one another. The x-axis is elapsed time (minutes) and runs from 0 to 60 in increments of 10. The left-side y-axis is permeate density reduction (%) and runs from 0 to 100 in increments of 10. The right-side y-axis is permeate cell density ($\times 10^6$ cells/mL) and runs from 0.00 to 2.50 in increments of 0.50. The uppermost solid line represents permeate reduction density (%). The lowermost solid line represents permeate cell density. The middle line running substantially horizontally across the page represents feed cell density for reference purposes.

[0038] FIG. 14 is a graph showing the T-cell concentration performance of an acoustophoretic process according to the present disclosure with a low cell density culture. The x-axis is elapsed time (minutes) and runs from 0 to 25 in increments of 5. The left-side y-axis is percent reduction (%) and runs from 0 to 100 in increments of 10. The right-side y-axis is cell density ($\times 10^6$ cells/mL) and runs from 0.00 to 1.60 in increments of 0.20. The upper solid line represents permeate reduction (%). The lower solid line represents permeate cell density. The dashed line represents feed cell density for reference purposes.

[0039] FIG. 15 is a graph showing the percent density reduction (PDR) dependency on concentration and flow rate for an acoustophoretic process according to the present disclosure. The x-axis is time (minutes) and runs from 0 to 40 in increments of 5. The y-axis is permeate density reduction (%) and runs from 0 to 100 in increments of 10. The line having circle-shaped data points represents a mixture having an initial cell concentration of 5×10^6 cells/mL. The line having x-shaped data points represents a mixture having an initial cell concentration of 3×10^6 cells/mL. The line having triangle-shaped data points represents a mixture having an initial cell concentration of 1×10^6 cells/mL at a flow rate of 20 mL/minute. The line having diamond-shaped data points represents a mixture having an initial cell concentration of 1×10^6 cells/mL at a flow rate of 10 mL/minute.

[0040] FIG. 16 is a graph showing the T-cell performance for an acoustophoretic process according to the present disclosure with a high cell density culture. The x-axis is elapsed time (minutes) and runs from 0 to 25 in increments of 5. The left-side y-axis is percent reduction (%) and runs from 0 to 100 in increments of 10. The right-side y-axis is cell density ($\times 10^6$ cells/mL) and runs from 0.00 to 3.00 in increments of 0.50. The upper solid line represents permeate density reduction (%). The lower solid line represents permeate cell density. The dashed line represents feed cell density for reference purposes.

[0041] FIG. 17 is a perspective view of an example acoustophoretic device according to the present disclosure including a cooling unit for cooling the transducer.

[0042] FIG. 18 is a graph showing the temperature profile of an acoustophoretic device without active cooling. The x-axis is elapsed time (minutes) and runs from 0.00 to 20.00 in increments of 2.00. The y-axis is temperature ($^{\circ}\text{C}$) and runs from 17.00 to 33.00 in increments of 2.00. The lowermost line along the right side of the graph represents the feed temperature ($^{\circ}\text{C}$). The uppermost line along the right side of the graph represents the core temperature ($^{\circ}\text{C}$). The middle line along the right side of the graph represents the permeate temperature ($^{\circ}\text{C}$).

[0043] FIG. 19 is a graph showing the temperature profile of an acoustophoretic device with active cooling of the transducer. The x-axis is elapsed time (minutes) and runs from 0.00 to 20.00 in increments of 2.00. The y-axis is temperature ($^{\circ}\text{C}$) and runs from 17.00 to 33.00 in increments of 2.00. The lowermost line along the right side of the graph represents the feed temperature ($^{\circ}\text{C}$). The uppermost line along the right side of the graph represents the core temperature ($^{\circ}\text{C}$). The middle line along the right side of the graph represents the permeate temperature ($^{\circ}\text{C}$).

[0044] FIG. 20 illustrates a process for concentrating, washing, and/or separating microcarriers and cells according to the present disclosure. The leftmost portion represents a first step of receiving microcarriers and cells surrounded by a bioreactor serum from a bioreactor and concentrating the microcarriers with attached cells in an acoustophoretic device according to the present disclosure. The middle portion represents a second step of washing the concentrated microcarriers with attached cells to remove the bioreactor serum. The rightmost portion represents a third step of

trypsinizing the microcarriers and separating the microcarriers from the cells in a fourth step. The bottom portion represents a final wash and concentrate step that can be employed as needed.

[0045] **FIG. 21** shows media exchange in an acoustophoretic device according to the present disclosure. The “Concentrate” photograph shows the concentrate (e.g., concentrated microcarriers with attached T cells) surrounded by a first media (dyed red). The “Wash Pass 1” photograph shows the microcarriers with attached T cells after a first wash pass using a second media (dyed blue). The “Wash Pass 2” photograph shows the microcarriers with attached T cells after a second wash pass. The rightmost “Wash Pass 3” photograph shows the microcarriers with attached T cells after a third wash pass, and is almost completely blue.

[0046] **FIG. 22** shows microscopic images of the media exchange shown in **FIG. 21**. **FIG. 22** shows a microscopic image of the microcarriers with T attached cells in the feed and during the three wash passes, and the concentration of separated microcarriers and T cells in the permeate.

[0047] **FIG. 23** shows the concentration of T cells in the acoustophoretic device before acoustophoresis (top row of photographs) and after one acoustophoresis pass (bottom row of photographs).

[0048] **FIG. 24** shows the concentration of microcarriers with attached T cells in the feed into the acoustophoretic device (top row of photographs) and the concentration of separated microcarriers and T cells in the permeate drawn out of the acoustophoretic device (bottom row of photographs). The dark circular items indicate microcarriers, and the lighter area indicates T cells.

[0049] **FIG. 25** shows microscopic images of the concentration of microcarriers with attached T cells in the feed and the concentration of separated microcarriers and T cells in the permeate.

[0050] **FIG. 26** is a schematic of an example acoustophoretic system according to the present disclosure.

[0051] **FIG. 27** is a schematic of another example acoustophoretic system according to the present disclosure including waste and concentrate transfer bags.

[0052] FIG. 28 is a schematic of an example acoustophoretic system according to the present disclosure showing the flow path of the feed material through the system.

[0053] FIG. 29 is a schematic of the example acoustophoretic system of FIG. 28 showing the flow path of the wash material through the system.

[0054] FIG. 30 is a schematic of the example acoustophoretic system of FIG. 28 showing draining of the system.

[0055] FIG. 31 illustrates a culture bag for use in the acoustophoretic systems according to the present disclosure.

[0056] FIG. 32 illustrates the concentrate transfer bag of FIG. 31 disposed within a tank filled with fluid and a conveyor system for moving the transducer relative to the bag.

[0057] FIG. 33 illustrates moving the transducer from an upper portion of the bag to a lower portion of the bag to concentrate cellular material in the lower portion of the bag.

[0058] FIG. 34 illustrates concentrating the cellular material in the lower portion of the bag and sealing the bag between the upper and lower portions.

[0059] FIG. 35 illustrates removing the waste from the lower portion of the bag via the waste outlet, introducing a new wash buffer via the drain port, and then separating the lower portion of the bag containing the concentrated cellular material from the upper portion of the bag.

DETAILED DESCRIPTION

[0060] The present disclosure may be understood more readily by reference to the following detailed description of desired embodiments and the examples included therein. In the following specification and the claims which follow, reference will be made to a number of terms which shall be defined to have the following meanings.

[0061] Although specific terms are used in the following description for the sake of clarity, these terms are intended to refer only to the particular structure of the embodiments selected for illustration in the drawings, and are not intended to define or limit the scope of the disclosure. In the drawings and the following description below, it is to be understood that like numeric designations refer to components of like function. Furthermore, it should be understood that the drawings are not to scale.

[0062] The singular forms "a," "an," and "the" include plural referents unless the context clearly dictates otherwise.

[0063] As used in the specification and in the claims, the term "comprising" may include the embodiments "consisting of" and "consisting essentially of." The terms "comprise(s)," "include(s)," "having," "has," "can," "contain(s)," and variants thereof, as used herein, are intended to be open-ended transitional phrases, terms, or words that require the presence of the named components/steps and permit the presence of other components/steps. However, such description should be construed as also describing compositions or processes as "consisting of" and "consisting essentially of" the enumerated components/steps, which allows the presence of only the named components/steps, along with any impurities that might result therefrom, and excludes other components/steps.

[0064] Numerical values should be understood to include numerical values which are the same when reduced to the same number of significant figures and numerical values which differ from the stated value by less than the experimental error of conventional measurement technique of the type described in the present application to determine the value.

[0065] All ranges disclosed herein are inclusive of the recited endpoint and independently combinable (for example, the range of "from 2 grams to 10 grams" is inclusive of the endpoints, 2 grams and 10 grams, and all the intermediate values).

[0066] A value modified by a term or terms, such as "about" and "substantially," may not be limited to the precise value specified. The approximating language may correspond to the precision of an instrument for measuring the value. The modifier "about" should also be considered as disclosing the range defined by the absolute values of the two endpoints. For example, the expression "from about 2 to about 4" also discloses the range "from 2 to 4."

[0067] It should be noted that many of the terms used herein are relative terms. For example, the terms "upper" and "lower" are relative to each other in location, e.g. an upper component is located at a higher elevation than a lower component in a given orientation, but these terms can change if the device is flipped. The terms "inlet" and "outlet" are relative to a fluid flowing through them with respect to a given structure, e.g. a fluid flows

through the inlet into the structure and flows through the outlet out of the structure. The terms “upstream” and “downstream” are relative to the direction in which a fluid flows through various components, e.g. the flow fluids through an upstream component prior to flowing through the downstream component. It should be noted that in a loop, a first component can be described as being both upstream of and downstream of a second component.

[0068] The terms “horizontal” and “vertical” are used to indicate direction relative to an absolute reference, e.g. ground level. The terms “upwards” and “downwards” are also relative to an absolute reference; an upwards flow is always against the gravity of the earth.

[0069] The present application refers to “the same order of magnitude.” Two numbers are of the same order of magnitude if the quotient of the larger number divided by the smaller number is a value of at least 1 and less than 10.

[0070] The acoustophoretic technology of the present disclosure employs acoustic standing waves to concentrate, wash, and/or separate materials (such as particles or a secondary fluid) in a primary or host fluid. In particular, as shown in the upper left image (A) of **FIG. 1**, an ultrasonic transducer **T** creates an acoustic wave in the fluid, which interacts with a reflector **R** positioned across from the ultrasonic transducer to create an acoustic standing wave. Although a reflector **R** is illustrated in **FIG. 1**, another transducer may be used to reflect and/or generate acoustic energy to form the acoustic standing wave.

[0071] As shown in the upper right image (B) of **FIG. 1**, as the host fluid and material entrained in the host fluid flows upwards through the acoustic standing wave, the acoustic standing wave(s) traps (retains or holds) the material (e.g., secondary phase materials, including fluids and/or particles). The scattering of the acoustic field off the material results in a three-dimensional acoustic radiation force, which acts as a three-dimensional trapping field.

[0072] The three-dimensional acoustic radiation force generated in conjunction with an ultrasonic standing wave is referred to in the present disclosure as a three-dimensional or multi-dimensional standing wave. The acoustic radiation force is proportional to the particle volume (e.g. the cube of the radius) of the material when the particle is small

relative to the wavelength. The acoustic radiation force is proportional to frequency and the acoustic contrast factor. The acoustic radiation force scales with acoustic energy (e.g. the square of the acoustic pressure amplitude). For harmonic excitation, the sinusoidal spatial variation of the force drives the particles to the stable positions within the standing waves. When the acoustic radiation force exerted on the particles is stronger than the combined effect of fluid drag force and buoyancy and gravitational force, the particle can be trapped within the acoustic standing wave field, as shown in the upper right image (B) of **FIG. 1**.

[0073] As can be seen in the lower left image (C) of **FIG. 1**, this trapping results in coalescing, clumping, aggregating, agglomerating, and/or clustering of the trapped particles. Additionally, secondary inter-particle forces, such as Bjerkness forces, aid in particle agglomeration.

[0074] As the particles continue to coalesce, clump, aggregate, agglomerate, and/or cluster the particles can grow to a certain size at which gravitational forces on the particle cluster overcome the acoustic radiation force. At such size, the particle cluster can fall out of the acoustic standing wave, as shown in the lower right image (D) of **FIG. 1**.

[0075] Desirably, the ultrasonic transducer(s) generate a three-dimensional or multi-dimensional acoustic standing wave in the fluid that exerts a lateral force on the suspended particles to accompany the axial force so as to increase the particle trapping capabilities of the standing wave. A planar or one-dimensional acoustic standing wave may provide acoustic forces in the axial or wave propagation direction. The lateral force in planar or one-dimensional acoustic wave generation may be two orders of magnitude smaller than the axial force. The multi-dimensional acoustic standing wave may provide a lateral force that is significantly greater than that of the planar acoustic standing wave. For example, the lateral force may be of the same order of magnitude as the axial force in the multi-dimensional acoustic standing wave.

[0076] The acoustic standing waves of the present disclosure can be used to trap particles (e.g. therapeutic cells such as T cells, B cells, NK cells) suspended in a first media in the standing wave. The first media can then be replaced with a second media (e.g., a biocompatible wash or buffer solution). Put another way, the host fluid of the

particles can be replaced. Prior to replacing the first media with the second media, acoustophoresis can be used to perform a diafiltration process, as shown in **FIG. 2**.

[0077] In **FIG. 2**, starting with an initial mixture that has a low cell density of, for example, less than 1×10^6 cells/mL, acoustophoresis can be used to reduce the volume of the initial mixture, for example by at least 10x, including 20x and up to 100x or more. The cell concentration may be increased by at least 10x, including 20x and up to 100x or more. This initial reduction process is the first volume reduction step (A). Next, the second media (e.g., a biocompatible wash or buffer solution) can be introduced to at least partially displace the first media, as indicated in step (B). Next, the new mixture of the cells and second media can be subjected to an acoustophoretic volume reduction step (C). This series of operations is referred to as a “diafiltration” process.

[0078] **FIG. 3** illustrates a single-step, push-through process in which particles / cells are trapped in the acoustic standing wave and held in the acoustophoretic device. The second media (e.g., a biocompatible wash or buffer solution) is then flowed into the acoustophoretic device to effectively “wash out” the first media. With the push-through process, more than 90%, including up to 99% or more, of the first media can be removed from the particles / cells. The push-through process can be employed as a continuous, single-use process that uses less buffer solution and less time than the diafiltration process of **FIG. 2**.

[0079] **FIG. 4** shows six photographs that, from left to right and top to bottom, show the progression of cells being trapped in an acoustophoretic device before a second media mixture (dyed blue) is flowed into the device and gradually replaces the first media (dyed red). In **FIG. 4**, a 150 mL feed volume was used with 80 mL of electroporation media wash for the second media. The concentrate was drawn off at a flow rate of 10 mL/minute. As can be seen in these pictures, over time the first media is replaced with the second media.

[0080] With reference now to **FIG. 5** and **FIG. 6**, a first example embodiment of an acoustophoretic device **100** for separation of particles / cells from fluid is depicted. The acoustophoretic device **100** includes a flow chamber **110** having at least one inlet and at least one outlet. In this embodiment, the flow chamber **110** includes inlet **112**, permeate outlet **114**, concentrate outlet **116**, an ultrasonic transducer **120**, and a reflector **130**. The

inlet **112** can, in certain embodiments, serve the dual function of introducing the cells surrounded by the first media into the flow chamber **110** in addition to introducing the second media into the flow chamber **110**. Alternatively, separate inlets can be used for introducing the first and second media.

[0081] The flow chamber **110** is the region of the device **100** through which is flowed the cells surrounded by the first media. In this embodiment, the flow chamber **110** is defined by inlet **112**, permeate outlet **114**, and concentrate outlet **116**. The flow chamber **110** is further defined by a sidewall **115** to which the ultrasonic transducer **120** and the reflector **130** are coupled. As seen here, the sidewall is shaped so that the ultrasonic transducer and reflector are located on opposite sides thereof.

[0082] Inlet **112** is located at a first end **106** of the flow chamber **110**. In particular embodiments, the ingress of material through the inlet **112** can be configured to occur toward the bottom end of the inlet **112**, such that the inflow of fluid into the flow chamber **110** occurs closer to the bottom end of the flow chamber **110** than the top end thereof.

[0083] As depicted in **FIG. 5** and **FIG. 6**, the inlet **112** is located along a first side **107** of the device **100**. The first side **107** of the device also houses the reflector **130**, while a second side **109** of the device, opposite the first side thereof, houses the ultrasonic transducer **120**. The inlet **112** could alternatively be located along the second side **109** of the device (e.g., on the same side as the ultrasonic transducer) or on another side of the device.

[0084] In the embodiment depicted in **FIG. 5**, the permeate outlet **114** is located at a second end **108** of the flow chamber **100**. The permeate outlet **114** is generally used to recover the first media and residual cells from the flow chamber **110**. In comparison, the concentrate outlet **116** is located between the inlet **112** and the permeate outlet **114**, below the ultrasonic transducer **120** and the reflector **130**. The concentrate outlet **116** is generally configured to recover the cells from the flow chamber **110**. In certain embodiments, however, it may be desired to recover other material (e.g., microcarriers) from the device, in which case the microcarriers can be recovered by the concentrate outlet and the cells can be recovered via the permeate outlet along with the media). As seen here, the permeate outlet **114** is generally located above the ultrasonic transducer

120 and the reflector **130**, while and the concentrate outlet **116** is generally located below the ultrasonic transducer **120** and the reflector **130**.

[0085] In the embodiment depicted in **FIG. 5** and **FIG. 6**, the device **100** is vertically oriented, such that the first end **106** of the device is the bottom end thereof and the second end **108** of the device is the top end thereof. In this way, the cells surrounded by the first media is introduced at the bottom end of the device **100** and flows vertically upwards through the flow chamber from the inlet **112** toward the permeate outlet **114**.

[0086] As can be best seen in **FIG. 6**, the device **100** also includes a collector **140**. The collector **140** is located in the flow chamber **110** between the inlet **112** and the ultrasonic transducer **120** and the reflector **130**. The collector **140** is located above the concentrate outlet **116** and, in particular, is defined by angled walls **142** that lead to the concentrate outlet **116**. Put another way, the collector **140** leads into a common well defined by angled walls **142** that taper downwards in cross-sectional area (i.e. larger area to smaller area) to a vertex at the bottom of the collector, which is fluidically connected to and drains off one side into the concentrate outlet **116** via flowpath **119**. In this way, the multi-dimensional acoustic standing wave can direct the concentrated cells to the collector **140** for collection and removal from the flow chamber **110** via the concentrate outlet **116**. An annular plenum **117** surrounds the collector **140**, permitting the mixture of host fluid / cells to flow from the inlet **112** around the collector **140** into the flow chamber **110**.

[0087] In some embodiments, the collector leads to a collection container that is filled with the second media. In this way, the second media is not flowed through the flow chamber of the device. Instead, as the cells are trapped in the acoustic standing wave and form clusters that grow to a critical size and subsequently fall out of the multi-dimensional acoustic standing wave, the cell clusters fall into the collector and are led to the collection container. The collection container can be separable from the rest of the device.

[0088] As seen here, preferably, fluid flows through the device upwards. The cells surrounded by the first media enters the device through inlet **112** at a bottom end of the device and then makes a sharp turn to flow upwards. This change in direction desirably reduces turbulence, producing near plug flow upwards through the device. Flow

continues upwards through the annular plenum **117** and up into the flow chamber **110**. There, the cells encounter the multi-dimensional acoustic standing wave(s), which traps the cells, as explained herein. Concentration of the cells occurs within the acoustic standing wave(s), which can also cause coalescence, clumping, aggregation, agglomeration and/or clustering of the cells.

[0089] As the cells are concentrated, they eventually overcome the combined effect of the fluid flow drag forces and acoustic radiation force, and they fall downwards into collector **140**. They can then be flowed through flowpath **119** and collected at concentrate outlet **116**. A much higher number of cells is obtained in a smaller volume (i.e., the target cells are concentrated).

[0090] **FIG. 7** is a graph showing the performance of the acoustophoretic device of **FIG. 5**. The device was operated at a fixed frequency of 2.234 MHz for a mixture having a feed cell density of about 1.5×10^6 cells/mL. As can be seen, the device achieved a permeate density reduction (PDR) of greater than 95% over about 35 minutes and a permeate cell density of less than 0.10×10^6 cells/mL over the same time period.

[0091] The piezoelectric transducer(s) of the acoustophoretic devices and systems of the present disclosure can be single monolithic piezoelectric materials or can be made from an array of piezoelectric materials. The piezoelectric material can be a ceramic material, a crystal or a polycrystal, such as PZT-8 (lead zirconate titanate). **FIG. 8** shows a monolithic, one-piece, single electrode piezoelectric crystal **200**. The piezoelectric crystal has a substantially square shape, with a length **203** and a width **205** that are substantially equal to each other (e.g. about one inch). The crystal **200** has an inner surface **202**, and the crystal also has an outer surface **204** on an opposite side of the crystal which is usually exposed to fluid flowing through the acoustophoretic device. The outer surface and the inner surface are relatively large in area, and the crystal is relatively thin (e.g. about 0.040 inches for a 2 MHz crystal).

[0092] **FIG. 9** shows a piezoelectric crystal **200'** made from an array of piezoelectric materials. The inner surface **202** of this piezoelectric crystal **200'** is divided into a piezoelectric array **206** with a plurality of (i.e. at least two) piezoelectric elements **208**. However, the array is still a single crystal. The piezoelectric elements **208** are separated from each other by one or more channels or kerfs **210** in the inner surface **202**. The width

of the channel (i.e. between piezoelectric elements) may be on the order of from about 0.001 inches to about 0.02 inches. The depth of the channel can be from about 0.001 inches to about 0.02 inches. In some instances, a potting material **212** (e.g., epoxy, Sil-Gel, and the like) can be inserted into the channels **210** between the piezoelectric elements. The potting material **212** is non-conducting, acts as an insulator between adjacent piezoelectric elements **208**, and also acts to hold the separate piezoelectric elements **208** together. Here, the array **206** contains sixteen piezoelectric elements **208** (although any number of piezoelectric elements is possible), arranged in a rectangular 4x4 configuration (square is a subset of rectangular). Each of the piezoelectric elements **208** has substantially the same dimensions as each other. The overall array **200'** has the same length **203** and width **205** as the single crystal illustrated in **FIG. 8**.

[0093] **FIG. 10** shows another embodiment of a transducer **200''**. The transducer **200''** is substantially similar to the transducer **200'** of **FIG. 9**, except that the array **206** is formed from twenty-five piezoelectric elements **208** in a 5x5 configuration. Again, the overall array **200''** has the same length **203** and width **205** as the single crystal illustrated in **FIG. 8**.

[0094] Each piezoelectric element in the piezoelectric array of the present disclosure may have individual electrical attachments (e.g. electrodes), so that each piezoelectric element can be individually controlled for frequency and power. These elements can share a common ground electrode. This configuration allows for not only the generation of a multi-dimensional acoustic standing wave, but also improved control of the acoustic standing wave. In this way, it is possible to drive individual piezoelectric elements (or multiple, separate ultrasonic transducers) with arbitrary phasing and/or different or variable frequencies and/or in various out-of-phase modes. For example, **FIG. 11** illustrates an exemplary 0-180-0-180 mode, though additional modes can be employed as desired, such as a 0-180-180-0 mode. For example, for a 5x5 array, additional modes can be employed as desired, such as a 0-180-0-180-0 mode, a 0-0-180-0-0 mode, a 0-180-180-180-0 mode, or a 0-90-180-90-0 mode. The array could also be driven, for example, such that a checkerboard pattern of phases is employed, such as is shown in **FIG. 11**. In summary, a single ultrasonic transducer that has been divided into an ordered

array can be operated such that some components of the array are out of phase with other components of the array.

[0095] The piezoelectric array can be formed from a monolithic piezoelectric crystal by making cuts across one surface so as to divide the surface of the piezoelectric crystal into separate elements. The cutting of the surface may be performed through the use of a saw, an end mill, or other means to remove material from the surface and leave discrete elements of the piezoelectric crystal between the channels/grooves that are thus formed.

[0096] As explained above, a potting material may be incorporated into the channels/grooves between the elements to form a composite material. For example, the potting material can be a polymer, such as epoxy. In particular embodiments, the piezoelectric elements **208** are individually physically isolated from each other. This structure can be obtained by filling the channels **210** with the potting material, then cutting, sanding or grinding the outer surface **204** down to the channels. As a result, the piezoelectric elements are joined to each other through the potting material, and each element is an individual component of the array. Put another way, each piezoelectric element is physically separated from surrounding piezoelectric elements by the potting material. **FIG. 12** is a cross-sectional view comparing these two embodiments. On top, a crystal as illustrated in **FIG. 9** is shown. The crystal is kerfed into four separate piezoelectric elements **208** on the inner surface **202**, but the four elements share a common outer surface **204**. On the bottom, the four piezoelectric elements **208** are physically isolated from each other by potting material **212**. No common surface is shared between the four elements.

[0097] **FIG. 13** is a graph showing the performance of an acoustophoretic device according to the present disclosure having a 16-element piezoelectric array. The piezoelectric array was operated at a fixed frequency of 2.244 MHz for a mixture having a feed cell density of about 2.00×10^6 cells/mL. As can be seen, the device achieved a permeate density reduction (PDR) of about 95% over about 60 minutes and a permeate cell density of about 0.10×10^6 cells/mL over the same time period.

[0098] The concentration efficiency of the acoustophoretic device was tested. First, a T-cell suspension having a cell density of 1×10^6 cells/mL was used. A feed volume of between about 500 and 1000 mL was used at a flow rate of 10-15 mL/minute. The results

are graphically depicted in **FIG. 14**. The device exhibited a concentration factor of between 10x and 20x, a 90% cell recovery, and a 77% washout efficiency (i.e., the amount of the first media that was displaced by the second media) over ten minutes of testing. A 10 °C temperature increase was observed.

[0099] A yeast mixture was then used to test the dependency of the percent density reduction (PDR) on concentration and flow rate. The results are graphically depicted in **FIG. 15**. As seen here, the higher initial cell concentrations generally resulted in a greater PDR. Additionally, the varied flow rate (from 20 mL/min to 10 mL/min) did not have an observed effect on the PDR.

[0100] The concentration efficiency of the acoustophoretic device was again tested with a higher cell density. A T-cell suspension having a cell density of 5×10^6 cells/mL was used. A feed volume of 1000 mL was used at a flow rate of 10-15 mL/minute. The results are graphically depicted in **FIG. 16**. The device exhibited a concentration factor of better than 10x, a 90% cell recovery, and a 77% washout efficiency over one hour of testing. A 10 °C temperature increase was again observed.

[0101] During testing, it was also discovered that active cooling of the ultrasonic transducer led to greater throughput and efficiency and more power. As such, a cooling unit was developed for actively cooling the transducer, such as cooling unit **7060** coupled to the rear wall **7013** of acoustophoretic device **7000** depicted in **FIG. 17**. The cooling unit **7060** includes an independent flow path that is separate from the flow path through the device containing the fluid that is to be exposed to the multi-dimensional acoustic standing wave. A coolant inlet **7062** is adapted to permit the ingress of a cooling fluid into the cooling unit. A coolant outlet **7064** serves as the outlet through which the coolant and waste heat exit the cooling unit. Here, the coolant inlet is located below the coolant outlet, though this path can be varied as desired. The coolant that flows through the cooling unit can be any appropriate fluid. For example, the coolant can be water, air, alcohol, ethanol, ammonia, or some combination thereof. The coolant can, in certain embodiments, be a liquid, gas, or gel. The coolant can be an electrically non-conductive fluid to prevent electric short-circuits. The cooling unit can be used to cool the ultrasonic transducer, which can be particularly advantageously when the device is to be run continuously with repeated processing and recirculation for an extended period of time (e.g., perfusion).

The cooling unit can also be used to cool the host fluid running through the device **7000**, if desired.

[0102] The advantages of providing a cooling unit for the transducer can be seen in **FIG. 18** and **FIG. 19**. **FIG. 18** graphically shows the temperature profile of the acoustophoretic device without any active cooling (e.g., without a cooling unit for the transducer). As seen in **FIG. 18**, the temperature difference between the feed and the core (e.g., the transducer) was 8.6 °C. **FIG. 19** graphically shows the temperature profile of the acoustophoretic device with active cooling (e.g., with a cooling unit for the transducer). As seen in **FIG. 19**, through the use of active cooling the temperature difference between the feed and the core was reduced to 6.1 °C.

[0103] **FIG. 20** illustrates a four-step process (with an optional fifth step) for concentrating, washing, and separating microcarriers from cells. The first step in the process involves concentrating the microcarriers with attached cells in an acoustophoretic device, such as those described herein. The microcarriers and attached cells can be introduced to the acoustophoretic device by receiving the microcarriers with attached cells from a bioreactor. In the bioreactor, the microcarriers and cells are suspended in a first media (e.g., growth serum or preservative material used to keep the cells viable in the bioreactor). The microcarriers with attached cells surrounded by the first media are concentrated by the acoustic standing wave(s) generated in the acoustophoretic device. In a second step, the concentrated microcarriers with attached cells are then washed with a second media to remove the first media (e.g., bioreactor growth serum or preservative material). The third step is to then introduce a third media containing an enzyme into the acoustophoretic device to detach the cells from the microcarriers through enzymatic action of the second media. In particular embodiments, trypsin is the enzyme used to enzymatically detach the cells from the microcarriers. The multi-dimensional acoustic standing wave can then be used to separate the cells from the microcarriers. Usually, this is done by trapping the microcarriers in the multi-dimensional acoustic standing wave, while the detached cells pass through with the third media. However, the cells can be trapped instead, if desired. Finally, the separated cells may optionally be concentrated and washed again, as desired.

[0104] After being concentrated and trapped / held in the multi-dimensional acoustic standing wave, the microcarriers can coalesce, clump, aggregate, agglomerate, and/or cluster to a critical size at which point the microcarriers fall out of the acoustic standing wave due to enhanced gravitational settling. The microcarriers can fall into a collector of the acoustophoretic device located below the acoustic standing wave, to be removed from the flow chamber.

[0105] During testing, steps one and two (i.e., concentration and washing) were performed using red and blue food dye to make colored fluid. The concentration mixture included SoloHill microcarriers in red fluid. The wash mixture included blue fluid and was passed through the device three times. The concentrate was observed under a microscope, as shown in the leftmost image of **FIG. 21**. The concentration step was shown to have a 99% efficiency. The remaining three images in **FIG. 21** show microscopic images after the first, second, and third wash passes, respectively. As seen from left to right in **FIG. 21**, the first media (dyed red) is progressively washed out by a second media (dyed blue) over a series of wash passes. The light absorbance data is shown in the table below.

Sample	Light Absorbance	
	Red (510 nm)	Blue (630 nm)
Feed	0.138	0.041
Wash Pass 1	0.080	0.066
Wash Pass 2	0.063	0.080
Wash Pass 3	0.054	0.084

[0106] The decrease in red light absorbance and increase in blue light absorbance evidences the feasibility of the washing steps.

[0107] **FIG. 22** shows microscopic images of the microcarriers and attached cells during the concentration and washing steps. In particular, the leftmost image in the top row shows the microcarriers and attached cells in the feed, prior to introduction into the acoustophoretic device. The rightmost image in the top row shows the microcarriers and attached cells in the permeate, after concentration in the acoustophoretic device. The

bottom row of images show the microcarriers and attached cells in the device during the washing step, namely during the first, second, and third wash passes, from left to right.

[0108] **FIG. 23** shows the concentration of T-cells after being separated in the acoustophoretic device. The top row of images show the T-cells before acoustophoresis with a concentration of $1.14 \pm 0.03 \times 10^6$ cells/mL. The bottom row of images show the T-cells after acoustophoresis with a concentration of $1.13 \pm 0.02 \times 10^6$ cells/mL. The comparable concentrations evidence that substantially all of the cells pass through the acoustophoretic device, as the concentration was substantially unchanged by acoustophoresis.

[0109] **FIG. 24** shows the presence of SoloHill microcarriers and T-Cells in the acoustophoretic device under 4x magnification. The top row of images show the microcarriers and cells in the feed before acoustophoresis. The bottom row of images show the microcarriers and cells in the permeate after the cells have been separated out by acoustophoresis. The difference in the number of microcarriers with the application of acoustophoresis evidences the feasibility of using the device for trapping the microcarriers in the device and separating the cells therefrom. The feasibility of this technique and the results are further evidenced by the images in **FIG. 25**, which show microscopic images of the microcarriers and cells in the feed (top row of images) and permeate (bottom row of images) after concentration and the first, second, and third washes, from left to right.

[0110] The testing of the acoustophoretic concentrating, washing, and separating process showed that the process is appropriate for cell therapy and microcarrier applications. The concentrate and wash steps were performed with a resulting efficiency of greater than 99%, and the separating step e.g., separating the cells from the microcarriers, was performed with greater than 98% efficiency.

[0111] **FIG. 26** depicts an example embodiment of an acoustophoretic system / process **3100** employing an acoustophoretic device **A**, such as the acoustophoretic devices previously described. Generally, the device **A** includes a feed port **3102**, a drain port **3104**, a wash outlet **3108**, and an ultrasonic transducer **3120** configured to create a multi-dimensional acoustic standing wave in the device, as explained in great detail herein.

[0112] The feed port **3102** of this example embodiment is generally configured to operate as an inlet to introduce a fluid into the device, with the fluid typically including material entrained therein, such as cells and/or microcarriers. As can be seen here, the feed port **3102** is connected to feed line **3112**. In this example embodiment, feed line **3112** begins with a swabable barb valve **D** (Halkey Roberts) upstream of the feed port **3102**. Also included in the feed line **3112** upstream of the feed port **3102** in this example embodiment are a disposable pump head **C** (NaoPump) and a temperature sensor **B** (SciLog SciTemp). The pump **C** can be used, for example, to regulate the flow rate of the acoustophoretic device so that gravity/buoyancy can act on cell clusters. The feed line **3112** generally terminates at the feed port **3102** of the device **A**.

[0113] The drain port **3104** of this example embodiment is generally configured to operate as a concentrate outlet for drawing off concentrate from the device **A**. As can be seen here, the drain port **3104** is connected to concentrate line **3114**. In this example embodiment, concentrate line **3114** begins at the drain port **3104** of the device **A** and terminates with a swabable barb valve **D** (Halkey Roberts) downstream of the drain port **3104**.

[0114] The wash outlet **3108** of this example embodiment is generally configured to remove material from the device **A**, such as separated cells and washed-out fluid and media. As can be seen here, the wash outlet **3108** is connected to wash line **3118**. In this example embodiment, wash line **3118** begins at the wash outlet **3108** of the device **A**. Also included in the waste line **3118** downstream of the waste outlet **3108** in this example embodiment is a temperature sensor **B** (SciLog SciTemp) and a swabable barb valve **D** (Halkey Roberts).

[0115] The feed line **3112**, concentrate line **3114**, and waste line **3118** of this example embodiment are customarily made of tubing, preferably biopharmaceutical grade tubing (e.g., AdvantaHex Biopharmaceutical Grade TPE tubing having a 3.18mm inner diameter and 6.35mm outer diameter).

[0116] Turning now to **FIG. 27**, another example embodiment of an acoustophoretic system / process **3200** is depicted. The acoustophoretic device **3200** of **FIG. 27** is very similar to the acoustophoretic system / process **3100** of **FIG. 26**. However, the acoustophoretic system / process **3200** depicted in **FIG. 32** includes a drain port **3104**

configured to operate as both a wash inlet and a concentrate outlet. In this way, the drain port **3104** is used to introduce a wash media / buffer into the device **A** and to draw off concentrate from the device **A**. Because of the dual purpose of the drain port **3104**, as can be seen here, the drain port **3104** is connected to both a concentrate line **3114** and a wash line **3116**. The concentrate line **3114** and the wash line **3116** are joined together upstream of the drain port **3104** by a valve / stopcock **F**. As can be seen here, wash line **3116** of this example embodiment begins at swabable barb valve **D** (Halkey Roberts), runs through the stopcock **F** (Halkey Roberts), and terminates at the drain port **3104**. The concentrate line **3114**, on the other hand, begins at the drain port **3104**, runs through the stopcock **F**, and terminates at a collection container **E** (Charter Medical transfer bag, 400 mL). In this way, the concentrate line **3114** and the wash line **3116** share the valve / stopcock **F**, where the two lines are joined and share a common tubing between the stopcock **F** and the drain port **3104**. Additionally, this acoustophoretic system / process **3200** differs from the acoustophoretic system / process **3100** depicted in **FIG. 31** by the replacement of the barb valve at the end of the waste line **1318** in system **3100** with a collection container **E** (Charter Medical transfer bag, 400 mL) in system **3200**. The feed line **3112**, concentrate line **3114**, wash line **3116**, and waste line **3118** are customarily made of tubing, preferably biopharmaceutical grade tubing (e.g., Escelero RNT Clean Flexible PVC tubing tubing having a 3.18mm inner diameter and 4.76mm outer diameter).

[0117] The use of collection containers **E** at the ends of the concentrate and waste lines advantageously creates an enclosed primary environment within which concentration, washing, and/or separation of cells and cellular materials can occur, which helps to prevent the cells / cell culture / cellular material from being exposed to possible intrusions, pathogens, or outside cellular influences that would be harmful.

[0118] **FIGS. 28-30** illustrate another example embodiment of an acoustophoretic system / process **2800** including a disposable acoustophoretic device **2810** with solenoid pinch valves that control the flow of fluid therethrough. Starting from the left-hand side of **FIG. 28**, the system includes a feed tank **2820**, a wash tank **2830**, and an air intake **2805**. The air intake **2805** runs through an air intake valve **2804**. Feed line **2821** runs from the feed tank **2820**. The air intake and the feed line **2821** are joined together by a Y-connector into common feed line **2811**, which runs into feed selector valve **2801**. A wash line **2831**

runs from the wash tank **2830**, and also runs into feed selector valve **2801**. Feed selector valve **2801** permits only one line to be open at a given time (valves **2802**, **2803** also operate in this manner). Wash line **2831** and feed line **2811** are joined together by a Y-connector downstream of the feed selector valve **2801** into input line **2812**. Input line **2812** passes through pump **2806** to inflow selector valve **2802**, which is downstream of the feed selector valve **2801** and upstream of the acoustophoretic device **2810**. The inflow selector valve **2802** selectively controls the inflow of feed or wash into the acoustophoretic device **2810** through either feed port **2602** or wash/drain port **2604**. A feed line **2813** runs from the inflow selector valve **2802** to feed port **2602**. A wash line **2814** runs from the inflow selector valve **2802** to common line **2815** and into wash/drain port **2604**.

[0119] On the right-hand side of **FIG. 28**, an outflow selector valve **2803** is located downstream of the acoustophoretic device **2810** and controls the outflow of fluid therefrom. A waste line **2816** runs from waste port **2608** through outflow selector valve **2803** and subsequently to waste tank **2850**. The common line **2815** runs into drain line **2817**, which then passes through outflow selector valve **2803** and subsequently to concentrate tank **2840**. These tanks **2840**, **2850** can be, for example, bags such as the culture bag that will be described further herein in **FIG. 31**. The outflow selector **2803** thereby selectively controls the flow of fluid to the concentrate tank and waste tank.

[0120] **FIG. 28** also illustrates the flow path of the feed material through the system. In this example embodiment, feed selector valve **2801** is operated with the bottom open (and top closed), so that the feed from feed tank **2820** flows through. Inflow selector valve **2802** is operated with the top open (and bottom closed), so that the feed material enters the acoustophoretic device **2810** via feed port **2602**. The outflow selector valve **2803** is also operated with the top open (and bottom closed) so that the fluid / first media of the feed material flows through to waste tank **2850**. The targeted particles in the feed material (e.g., microcarriers or cells) are trapped in the acoustophoretic device **2810** by action of a multi-dimensional acoustic standing wave(s), as explained in detail herein.

[0121] **FIG. 29** illustrates the flow path of the wash material through the system. Feed selector valve **2801** is operated with the top open (and bottom closed), so that the wash material from wash tank **2830** flows through. The inflow selector valve **2802** is operated

with the bottom open (and top closed) and the outflow selector valve **2803** is operated with the top open (and bottom closed). As a result, the wash material enters the acoustophoretic device **2810** via wash/drain port **2604**, which operates as a wash inlet. Note that the closed outflow selector valve **2803** prevents the wash material from entering concentrate tank **2840**. The wash material can then pass through the acoustophoretic device **2810** and remove the first media (e.g., bioreactor serum or preservative material). The wash material then exits via waste port **2608**, and flows to waste tank **2850**. The target particles remain trapped in the acoustophoretic device **2810**.

[0122] **FIG. 30** illustrates the draining of the system (e.g., the collection of the target particles). Air intake valve **2804** is opened. The feed selector valve **2801** is operated with the bottom open (and top closed), and the inflow selector valve **2802** is operated with the top open (and bottom closed), so that air enters the acoustophoretic device **2810** via feed port **2602**. The air generally aids in dislodging the clusters of target particles from the acoustophoretic device **2810**. The outflow selector valve **2803** is operated with the bottom open (and top closed). The target particles flow out of wash/drain port **2604** through common line **2815**, through drain line **2817** and subsequently to concentrate tank **2840**.

[0123] **FIG. 31** depicts an example embodiment of a culture bag **3700** that can be used in the acoustophoretic device **2810** of **FIG. 28**. The culture bag is formed from a sidewall **3710** that surrounds an internal volume **3705**. The bag **3700** can be thought of as having an upper portion **3740** and a lower portion **3750**. The culture bag **3700** includes a fill port **3702** at an upper end **3701** thereof, and a drain port **3704** at a lower end **3703** of the bag **3700**. The upper end **3701** and lower end **3703** of the bag **3700** are located opposite one another.

[0124] The bag **3700** further includes a wash outlet **3706** at a bottom end **3705** of the upper portion **3740**. As seen here, the wash outlet **3706** is generally located above the drain port **3704** of the bag **3700**. A pipe connects the wash outlet **3706** to a wash inlet **3708** that is located in the lower portion **3750** of the bag.

[0125] The upper portion **3740** of the bag includes the fill port **3702** and the wash outlet **3708**. The lower portion **3750** includes the wash inlet **3708** and the drain port **3704**. In particular illustrative embodiments, the upper portion **3740** can have a volume of about

880 mL and the lower portion **3740** can have a volume of about 20 mL, although it is to be understood that the size and volume of the bag **3700** can be varied as desired and/or in accordance with a particular application. In particular embodiments, the lower portion comprises from about 1% to about 5% of the internal volume, with the upper portion comprising from about 95% to about 99% of the internal volume.

[0126] The bag **3700** is generally formed from a substantially acoustically transparent material, such as a polymeric material. For example, the bag may be made from at least one polymer layer (e.g., polyethylene, polypropylene, polyethylene terephthalate (PET), polymethylpentene and the like). The bag can be a multilayer bag (e.g., made from multiple layers of differentially functioning polymer layers). Those polymer layers may function as a waterproof layer, as a layer that provides strength, etc. For example, in some instances, the exterior (i.e. outermost layer) of the bag is a polyethylene terephthalate (PET) polymer. A middle or central layer of the bag can be typically ethylene vinyl alcohol (EVOH) or polyvinyl acetate (PVA). The interior layer can be typically a polyethylene polypropylene such as low-density polyethylene or very low density polyethylene. The bag has a large interior volume, generally of at least one liter, up to 1000 liters, and even larger as desired. The bag **3700** may be formed from any material suitable for allowing the passage of the acoustic standing wave(s) generated by the transducer(s) of the present disclosure therethrough.

[0127] The culture bag **3700** can be used in the acoustophoretic device **2810** of **FIG. 28**, or can be used in the concentrate tank **2840** or the waste tank **2850**. If used in the concentrate tank, the culture bag **3700** can be further processed to concentrate the target particles even more. This additional processing is illustrated in a system as shown in **FIG. 32**.

[0128] As seen in the left-side image of **FIG. 32**, the system includes a container **3800** that is filled with a fluid, such as water. An ultrasonic transducer **3820** is also provided. Generally, means for moving the transducer **3820** (along with a reflector, when desired) relative to the interior of the container are provided. For example, the transducer **3820** is cooperatively attached to a conveyor system **3850** that is configured to move the transducer **3820** vertically relative to the container **3800** and as indicated by the arrow.

The transducer can produce a multi-dimensional acoustic standing wave as previously described.

[0129] The right-side image of **FIG. 32** shows the culture bag **3700** in use disposed within the container **3800**. Generally, the movement of the transducer relative to the bag creates a “sweeping effect” through the media and particles in the bag **3700** from the upper end **3701** to the lower end **3703** (i.e., from the upper portion **3740** to the lower portion **3750** of the bag **3700**) or vice versa, depending on the direction of the vertical movement. This “sweeping” of the media in the bag improves the settling or buoyancy of particulate material (e.g., cells, cellular material) that is disposed within the media. While a conveyor system is depicted here for movement of the transducer relative to the container and the bag, it is to be understood that other suitable structures can be used to achieve the same means.

[0130] **FIG. 33** illustrates the process of causing material in the bag **3700** to settle into the lower portion **3750**. As seen on the left-hand side, the ultrasonic transducer **3820** begins at the top of the container, and moves downwards towards the lower portion **3750**. The ultrasonic transducer **3820** generates an acoustic standing wave that causes the particles **3790** to settle out. As seen in the right-hand side, the movement of the ultrasonic transducer **3820** while generating an acoustic standing wave results in the upper portion **3740** containing media with a reduced concentration of particles, and the lower portion **3750** containing media with an increased concentration of particles.

[0131] Referring now to the left-hand side of **FIG. 34**, the ultrasonic transducer **3820** has ended its cycle, and the particles are present in the lower portion **3750**. As seen on the right-hand side of **FIG. 34**, means **4000** may be provided in the system for sealing the culture bag between the upper portion **3740** and the lower portion **3750**. For example, in one embodiment, the means **4000** may be a heating bar that pinches the two sides of the culture bag together and heats the bag so as to form a seal between the upper portion and the lower portion. In other embodiments, the means **4000** can be a radio frequency (RF) sealer or an ultrasonic sealer.

[0132] Turning now to **FIG. 35**, it should be noted that the waste inlet **3708** is still part of the now-sealed lower portion **3750**. As illustrated here, a wash fluid or buffer can be introduced into the lower portion **3750** of the bag **3700** via the wash/drain port **3704**. This

wash fluid or buffer displaces the media that was originally present in the lower portion **3750**. The original media exits via wash inlet **3708** and wash outlet **3706**. Thus, in certain embodiments, the wash/drain port **3704** can serve the dual function of acting as both a concentrate outlet and a wash inlet, as previously explained. After washing the material in the lower portion **3750** of the bag **3700**, the upper and lower portions of the bag can be separated from one another as illustrated on the right-hand side of **FIG. 35**. The upper portion **3740** generally contains residual media, while the lower portion **3750** contains the target particles, which can be removed. After removal, the target particles (e.g. therapeutic cells) in the lower portion can be further processed and prepared for use with a patient.

[0133] The present disclosure has been described with reference to exemplary embodiments. Modifications and alterations may occur to others upon reading and understanding the preceding detailed description. It is intended that the present disclosure be construed as including all such modifications and alterations insofar as they come within the scope of the appended claims or the equivalents thereof.

CLAIMS:

1. A method of washing particles, the method comprising:
 - providing an initial mixture of a first media and particles to a chamber of an acoustophoretic device, the acoustophoretic device also comprising at least one ultrasonic transducer that includes a piezoelectric material;
 - driving the at least one ultrasonic transducer to create an acoustic standing wave in the chamber, such that at least a portion of the particles are trapped in the acoustic standing wave; and
 - mixing the trapped particles with a second media to wash the trapped particles.

2. The method of claim 1, further comprising:
 - providing the initial mixture to the chamber to obtain an intermediate mixture of the trapped particles in a reduced volume of the first media;
 - collecting the intermediate mixture;
 - mixing the intermediate mixture with the second media to form a secondary mixture; and
 - providing the secondary mixture to the chamber to obtain a final mixture of the trapped particles in a reduced volume of the second media.

3. The method of claim 1, wherein the second media is provided to the chamber after the initial mixture is provided to the chamber.

4. The method of claim 1, wherein the acoustophoretic device further comprises a collector for collecting the trapped particles therein, the collector located below the at least one ultrasonic transducer; and
 - wherein the collector leads to a collection container that contains the second media.

5. The method of claim 1, wherein the second media is a biocompatible wash or a buffer solution.

6. The method of claim 1, wherein the particles are cells.
7. The method of claim 6, wherein the cells are Chinese hamster ovary (CHO) cells, NS0 hybridoma cells, baby hamster kidney (BHK) cells, human cells, regulatory T-cells, Jurkat T-cells, CAR-T cells, B cells, or NK cells, peripheral blood mononuclear cells (PBMCs), algae, plant cells, bacteria, or viruses.
8. The method of claim 6, wherein the cells are attached to microcarriers.
9. The method of claim 1, wherein the piezoelectric material of the at least one ultrasonic transducer is in the form of a piezoelectric array formed from a plurality of piezoelectric elements.
10. The method of claim 9, wherein the piezoelectric elements are operated out of phase with each other.
11. The method of claim 1, wherein the acoustophoretic device further comprises a cooling unit for cooling the at least one ultrasonic transducer.
12. The method of claim 1, wherein the acoustic standing wave is a multi-dimensional acoustic standing wave.
13. The method of claim 1, wherein, over time, the second media gradually displaces the first media in the flow chamber of the acoustophoretic device.

14. A method of separating microcarriers from cells, comprising:
feeding an initial mixture of a first media and microcarriers with attached cells thereon through a flow chamber of an acoustophoretic device, the acoustophoretic device comprising at least one ultrasonic transducer including a piezoelectric material that is configured to be driven to create a multi-dimensional acoustic standing wave in the flow chamber;
driving the at least one ultrasonic transducer to create a multi-dimensional acoustic standing wave in the flow chamber, and to trap at least a portion of the microcarriers with attached cells in the multi-dimensional acoustic standing wave;
washing the trapped microcarriers with attached cells by flowing a second media through the flow chamber to remove the first media; and
flowing a third media containing an enzyme through the flow chamber to separate the cells from the microcarriers.
15. The method of claim 14, wherein the microcarriers remain trapped in the multi-dimensional acoustic standing wave, and further comprising recovering a mixture of the cells and the third media.
16. The method of claim 14, wherein the enzyme is trypsin.
17. A culture bag, comprising:
a sidewall that surrounds an internal volume, the internal volume including an upper portion and a lower portion;
a fill port at an upper end of the culture bag in the upper portion;
a drain port at a lower end of the culture bag in the lower portion; and
a wash outlet located at a bottom end of the upper portion between the fill port and the drain port;
wherein the upper portion has a larger diameter than the lower portion.
18. The culture bag of claim 17, wherein the wash outlet is connected to a wash inlet located in the lower portion of the culture bag.

19. The culture bag of claim 17, wherein the lower portion comprises from about 1% to about 5% of the internal volume.

20. An acoustophoretic system, comprising:
the culture bag of claim 17;
at least one ultrasonic transducer including a piezoelectric material that is configured to be driven to create a multi-dimensional acoustic standing wave in the culture bag; and
means for moving the at least one ultrasonic transducer relative to the culture bag between the upper end and the lower end thereof.

21. The acoustophoretic system of claim 20, further comprising a tank into which the culture bag can be placed, and wherein the means for moving the at least one ultrasonic transducer is a conveyor system located outside of the tank.

22. The acoustophoretic system of claim 20, further comprising means for sealing the culture bag between the upper portion and the lower portion thereof.

23. An acoustophoretic system, comprising:
an acoustophoretic device comprising a feed port, a drain port located below the feed port and configured to operate as (i) a wash inlet and (ii) a concentrate outlet, a wash outlet, and at least one ultrasonic transducer including a piezoelectric material that is configured to be driven to create a multi-dimensional acoustic standing wave;
a feed line leading to the feed port of the acoustophoretic device;
a waste line leading away from the waste outlet of the acoustophoretic device; and
a wash line leading to the drain port of the acoustophoretic device; and
a concentrate line leading away from the drain port of the acoustophoretic device.

24. The acoustophoretic system of claim 23, further comprising a valve to switch between the wash line and the concentrate line.

25. The acoustophoretic system of claim 23, wherein the feed line and the wash line pass through an inflow selector valve.

26. The acoustophoretic system of claim 25, further comprising a feed selector valve upstream of the inflow selector valve.

27. The acoustophoretic system of claim 25, where the waste line and the concentrate line pass through an outflow selector valve.

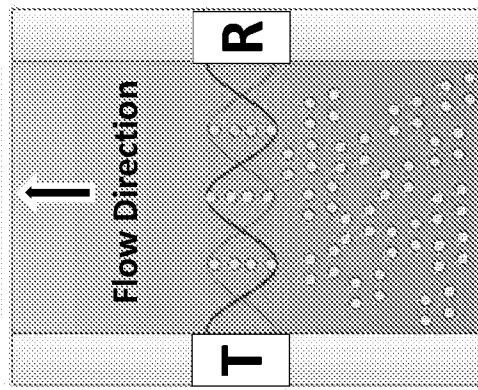

B

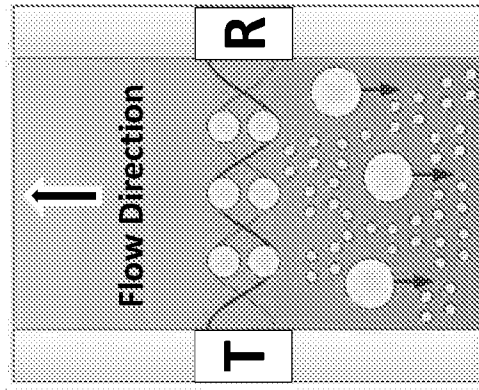

D

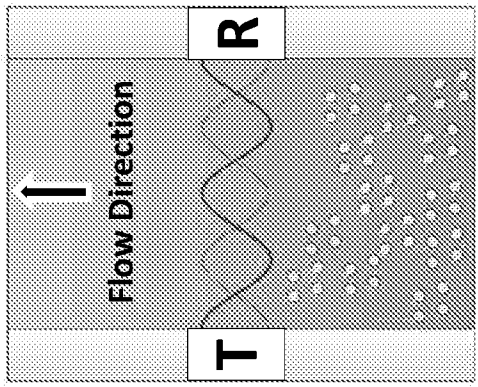

A

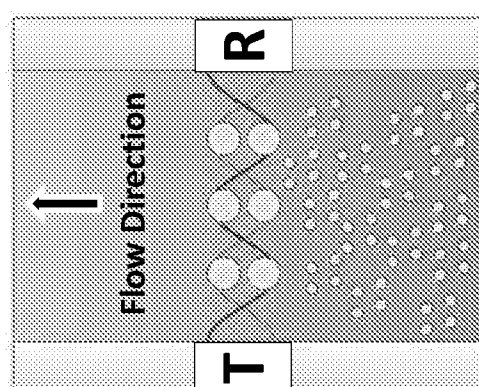

C

FIG. 1

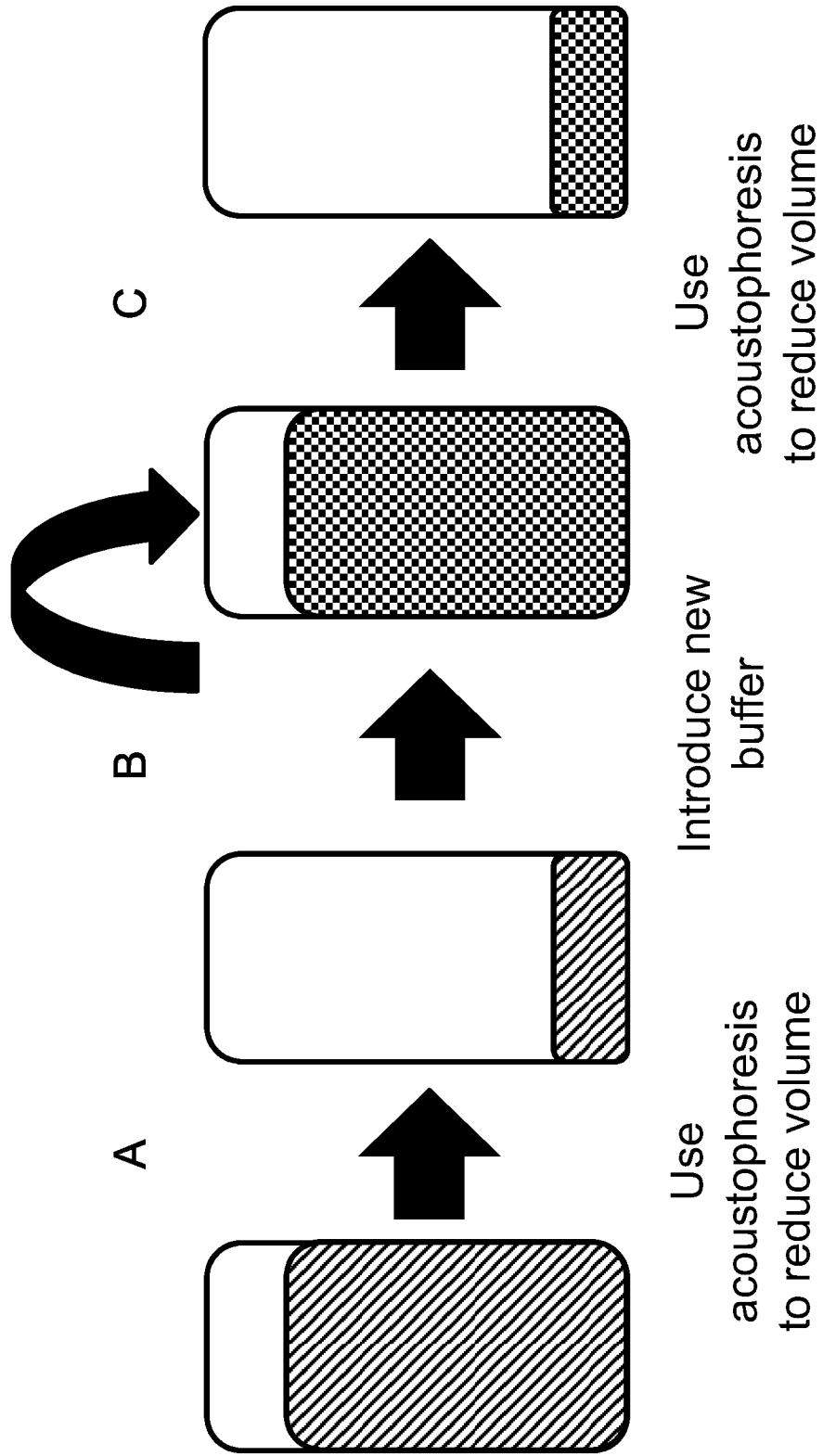

FIG. 2

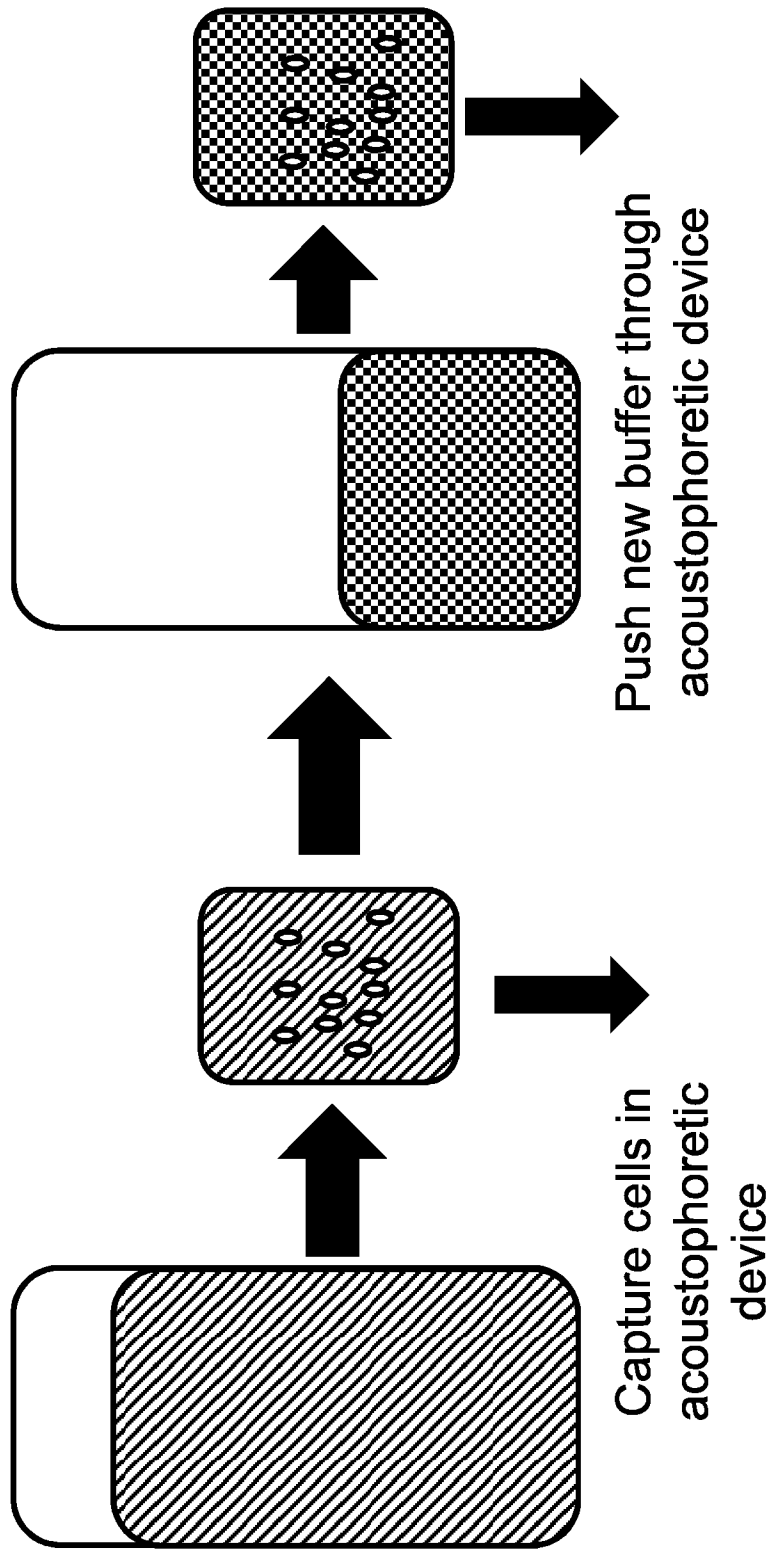

FIG. 3

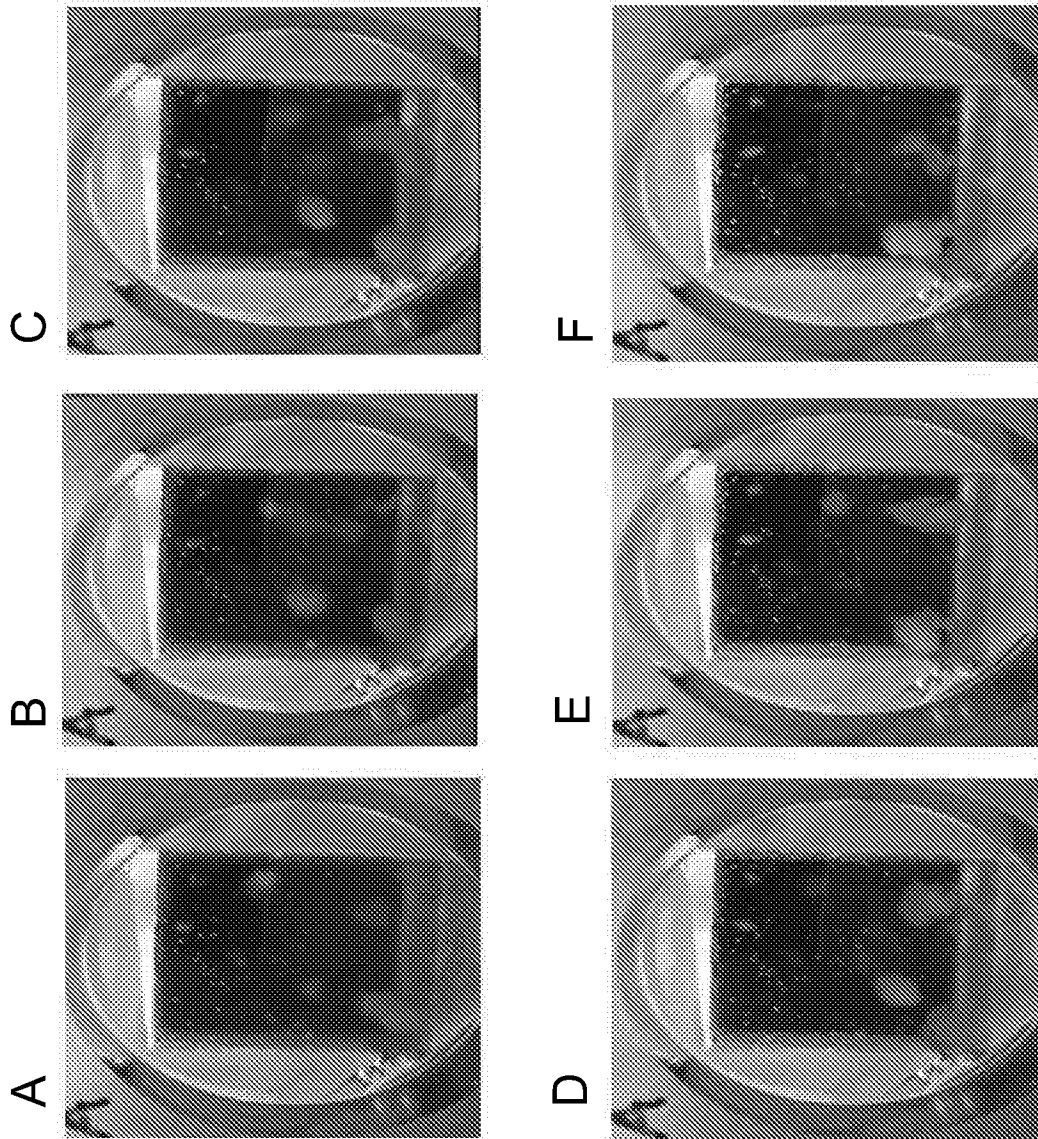

FIG. 4

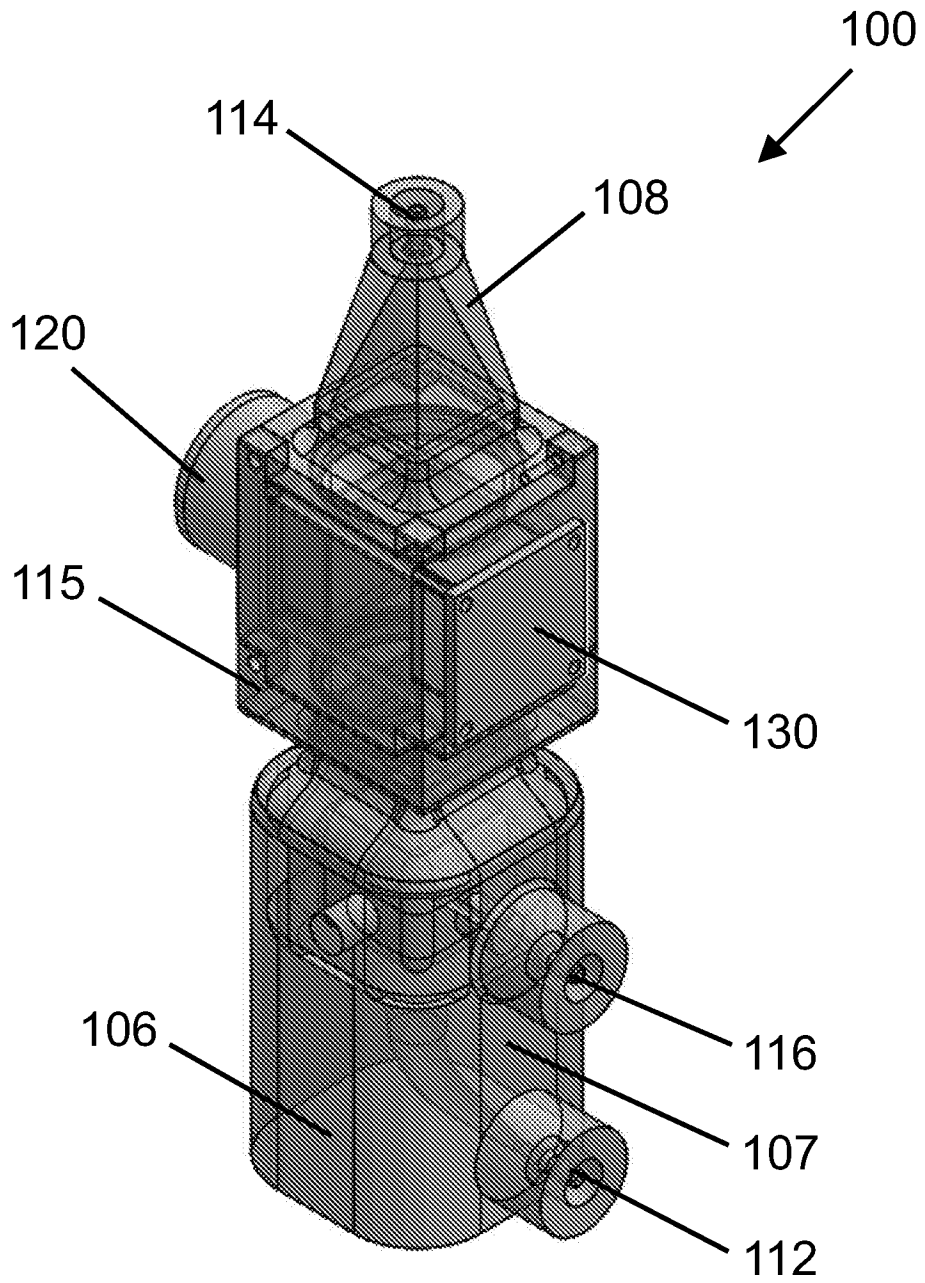

FIG. 5

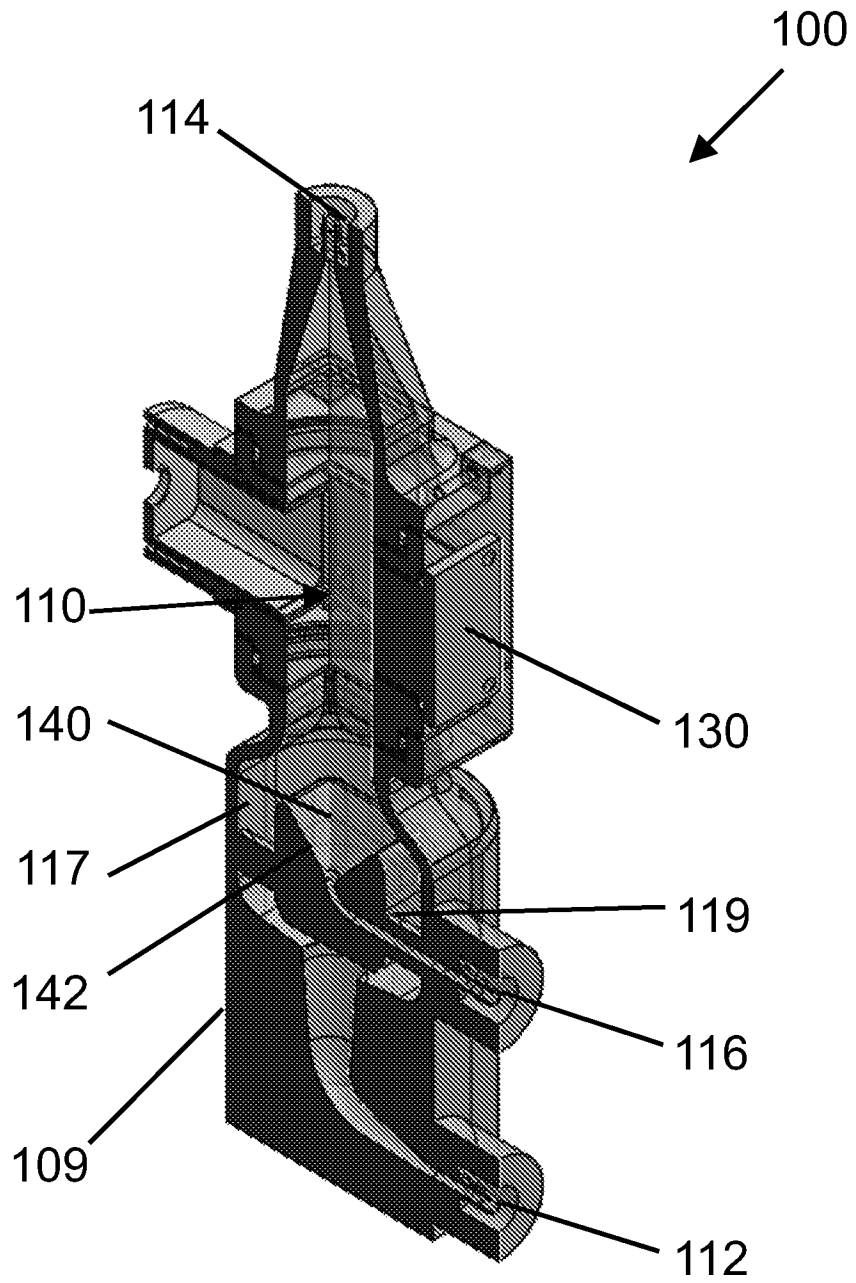

FIG. 6

2.234 MHz Fixed Frequency, Bare PZT, Modified Vertical
10W Power Track

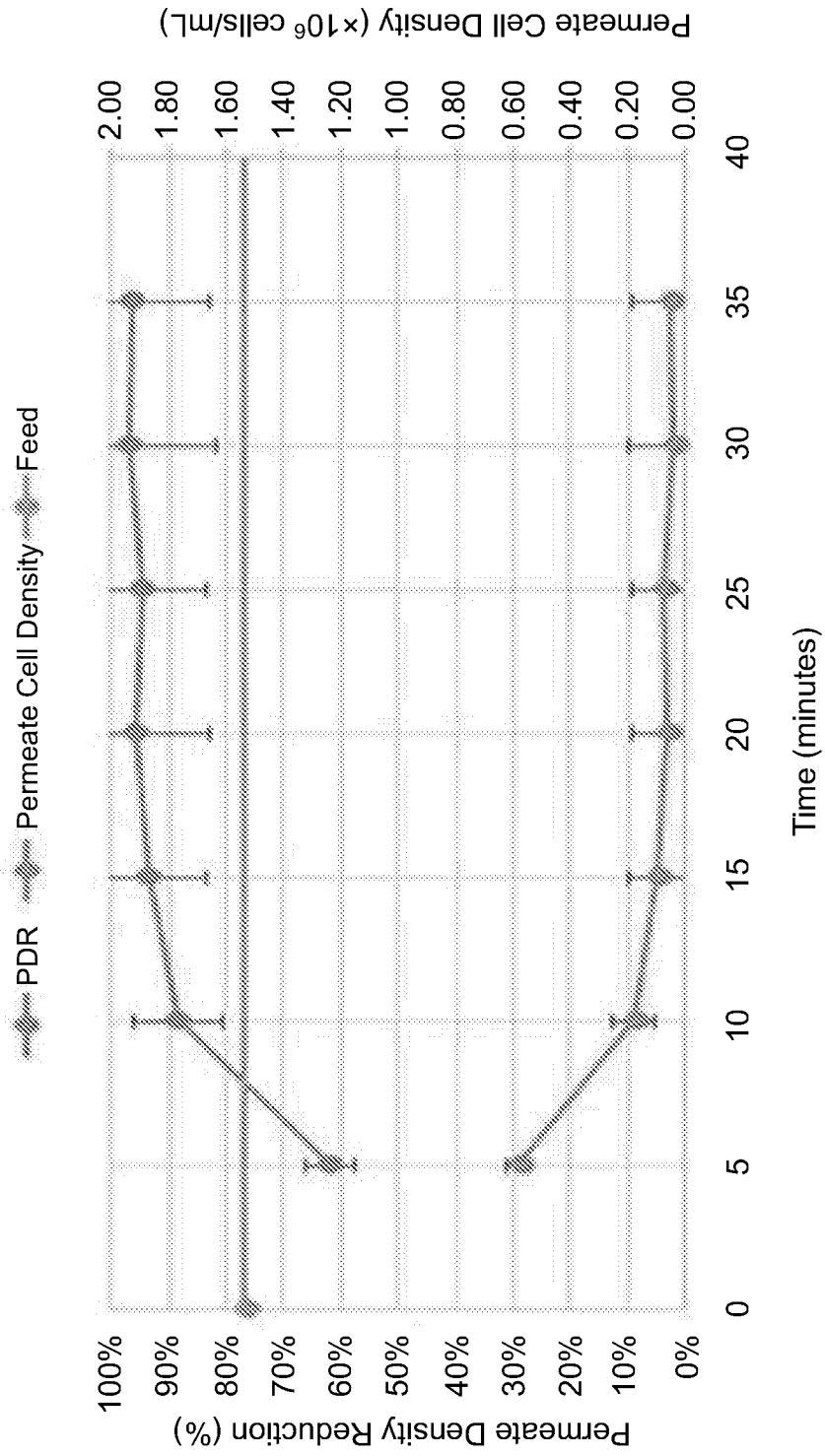

FIG. 7

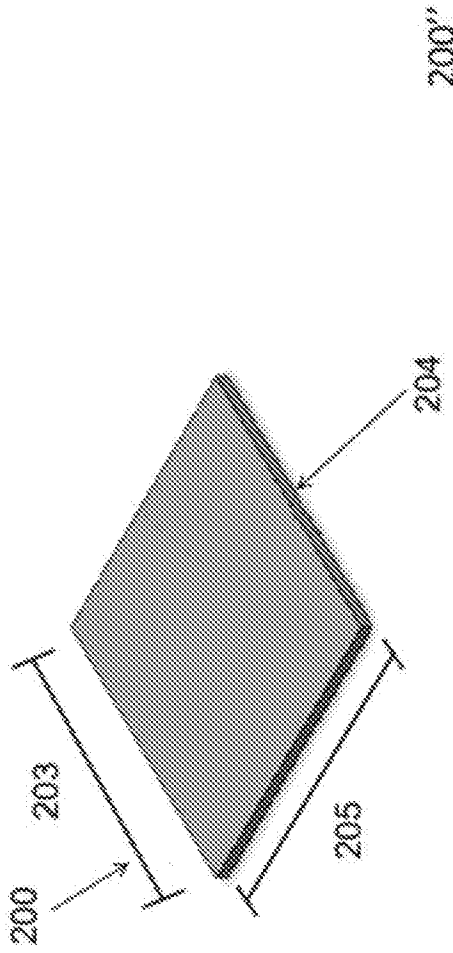

FIG. 8

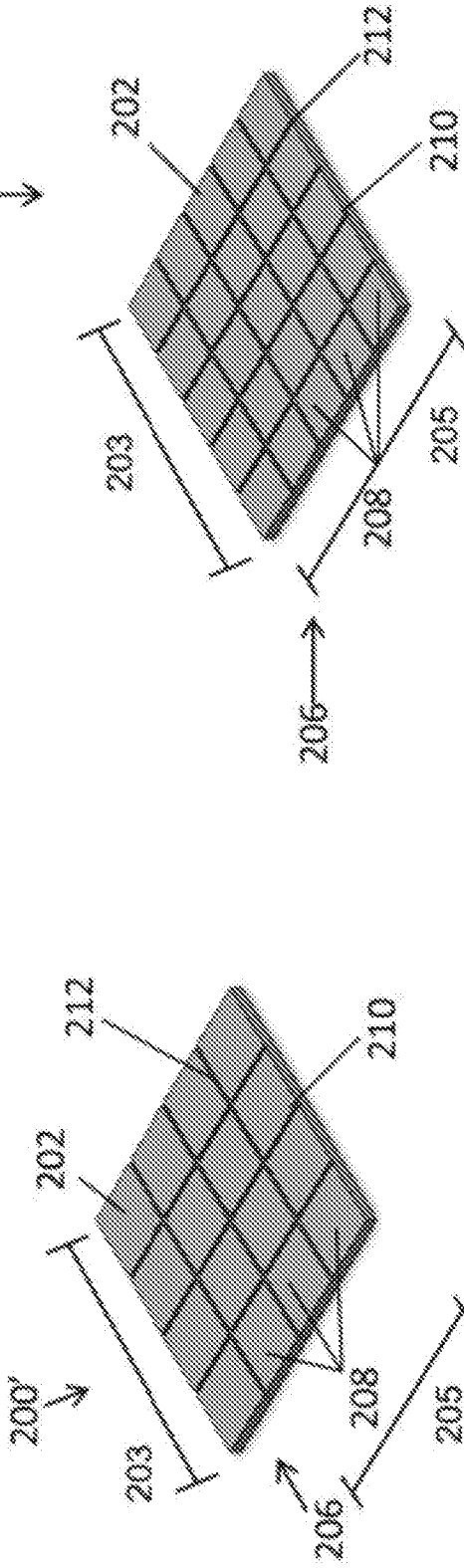

FIG. 9

FIG. 10

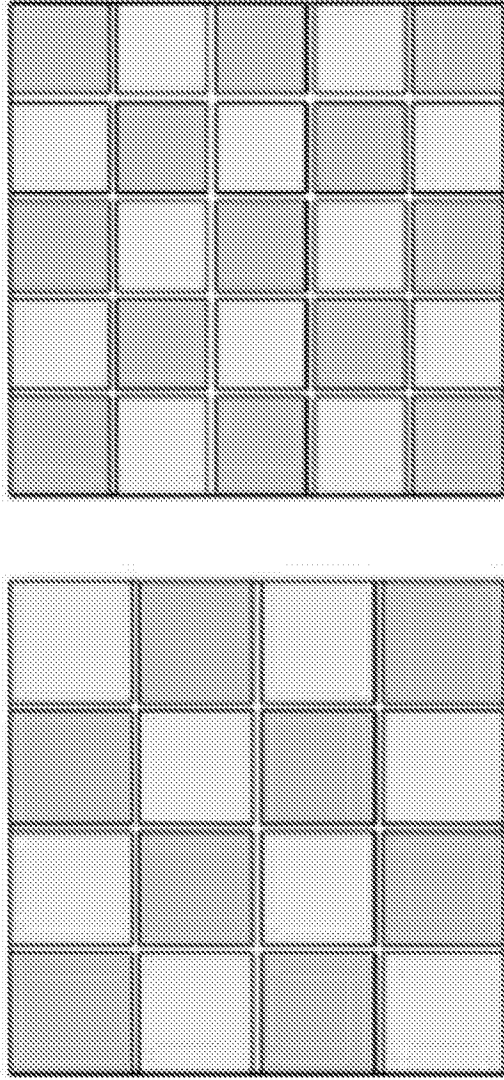

FIG. 11

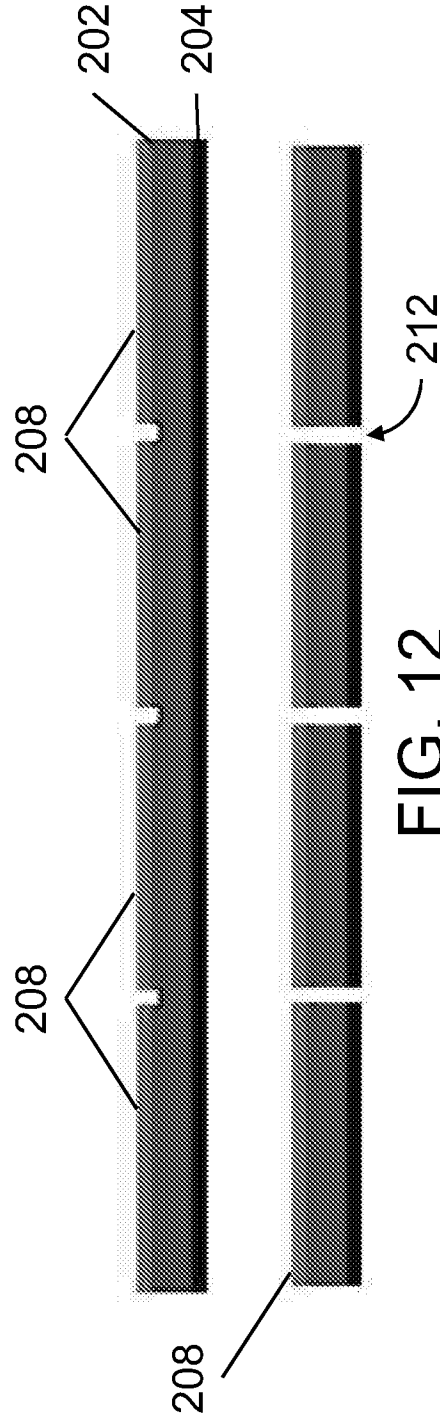

FIG. 12

2.244 MHz Fixed Frequency, 16-Element Array, In-Phase
Modified Vertical, 13.3W Power Track

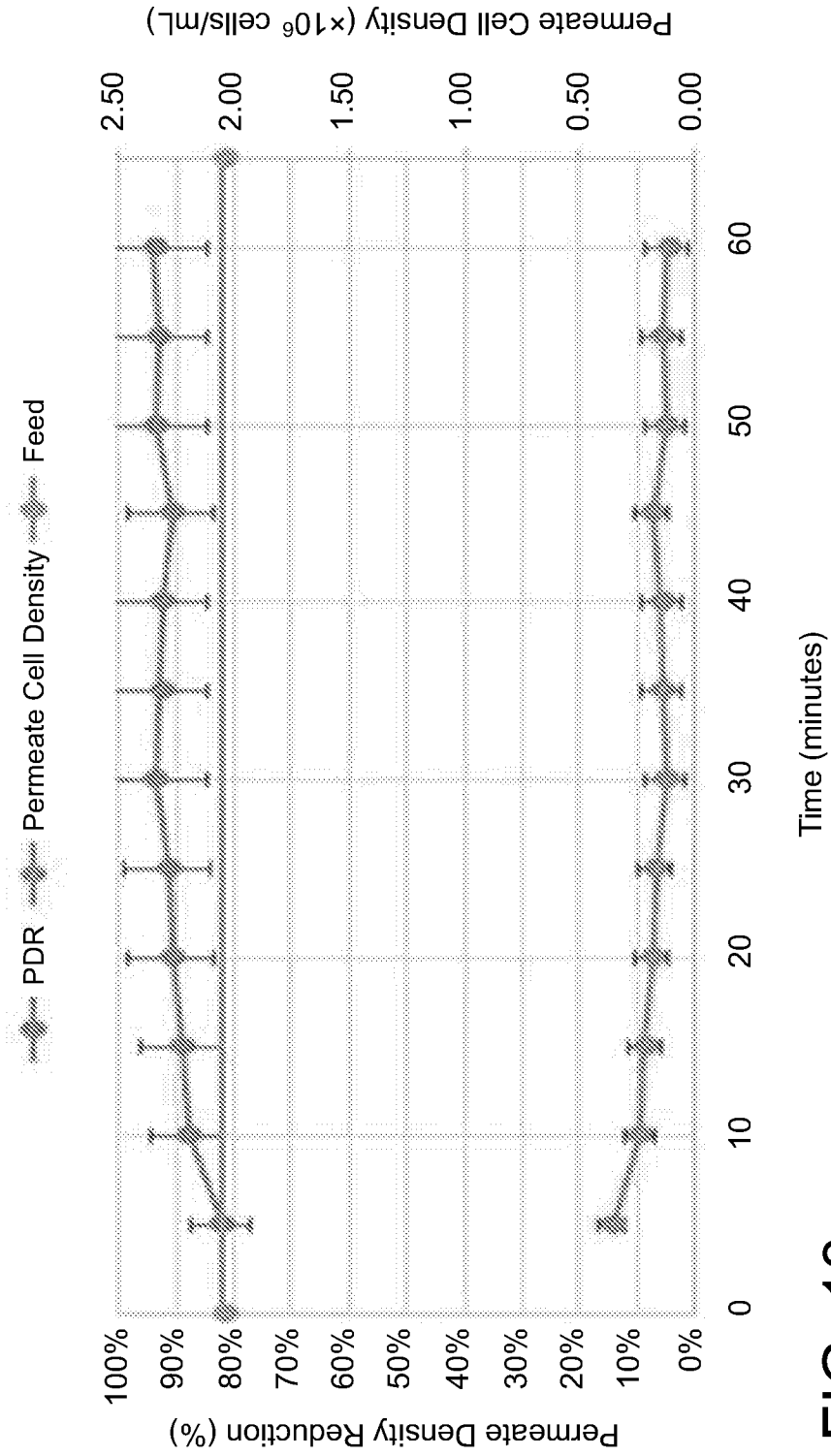

FIG. 13

T-cell Clarification Performance

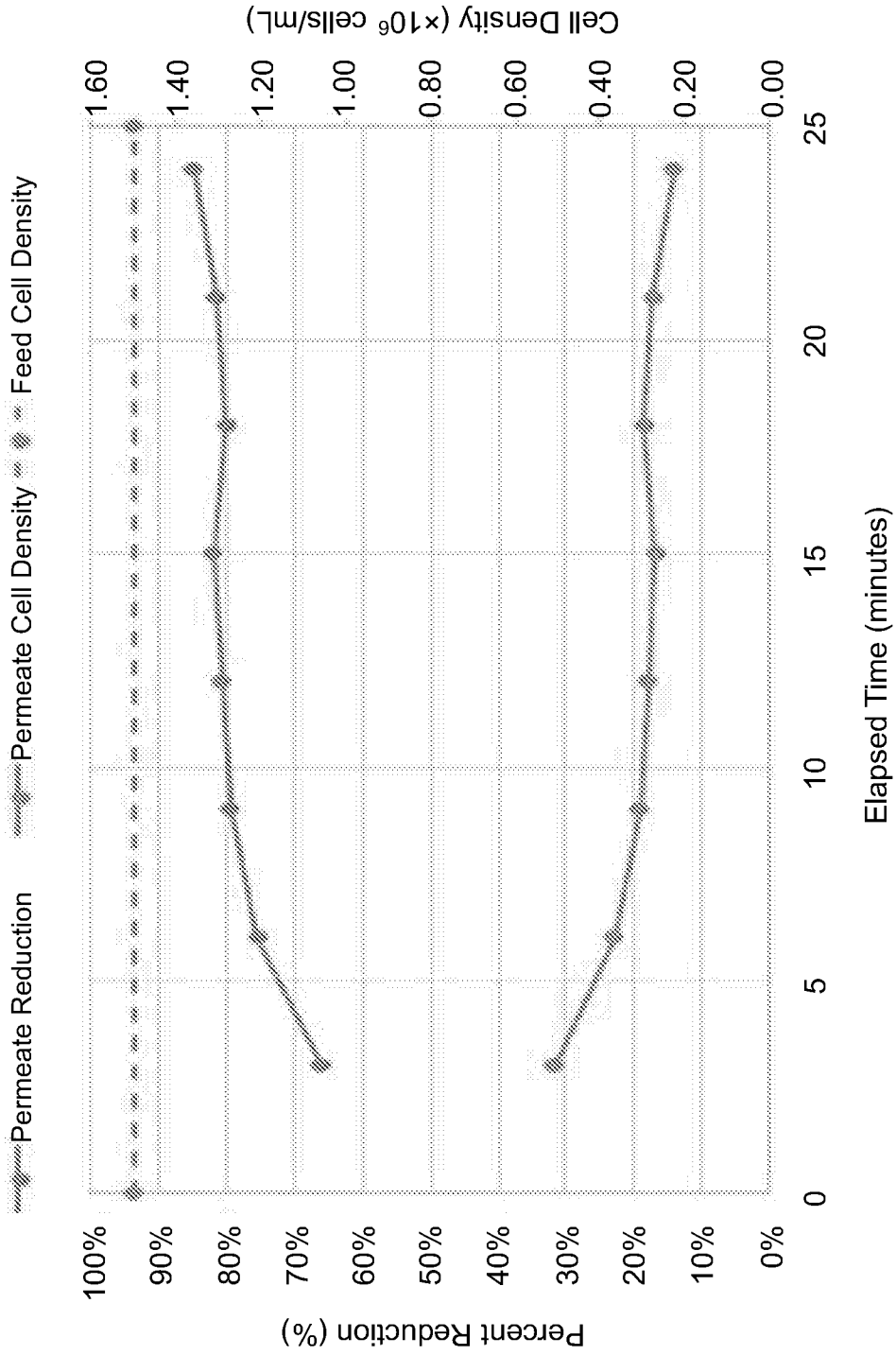

FIG. 14

PDR Dependency on Concentration and Flow Rate

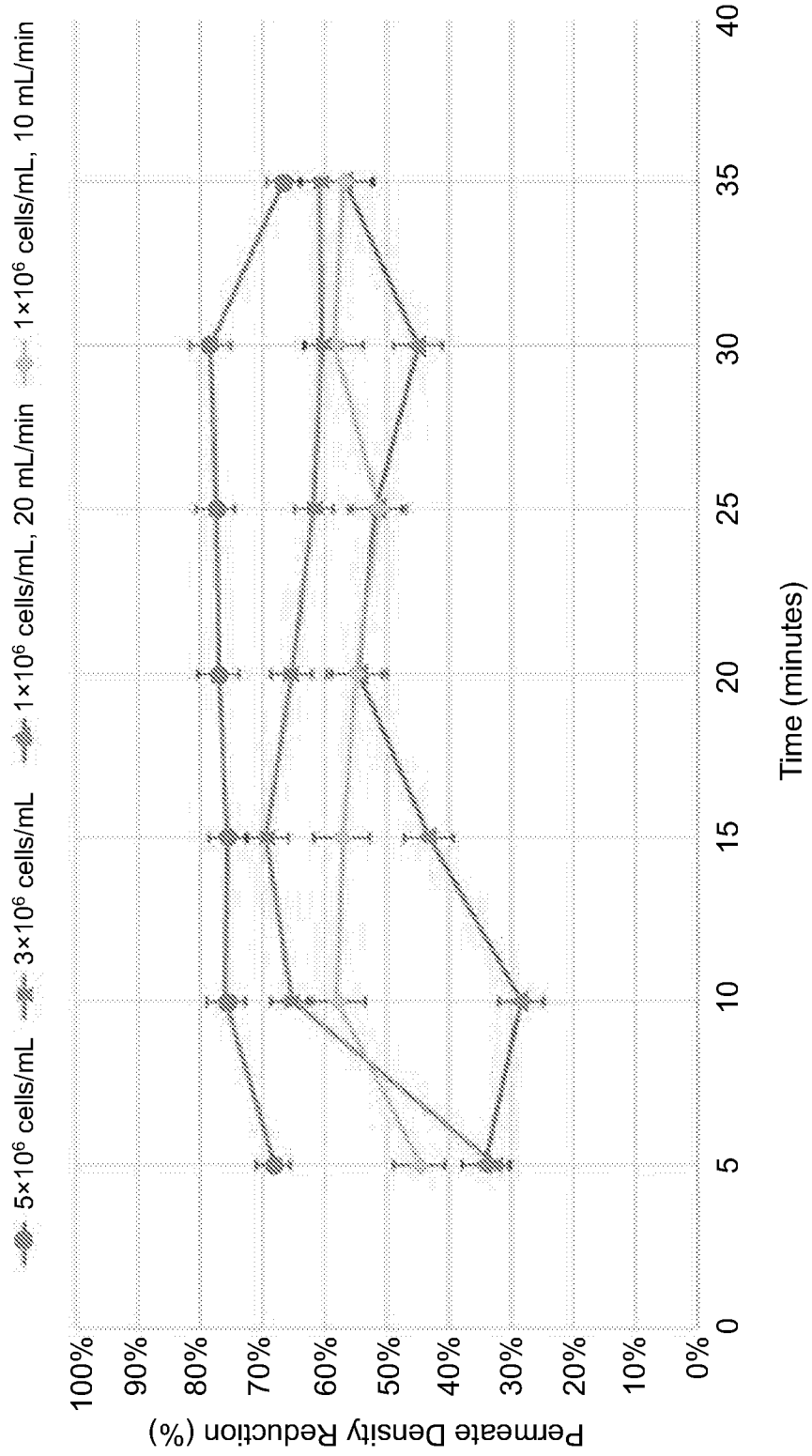

FIG. 15

Filtration at Higher T-Cell Density

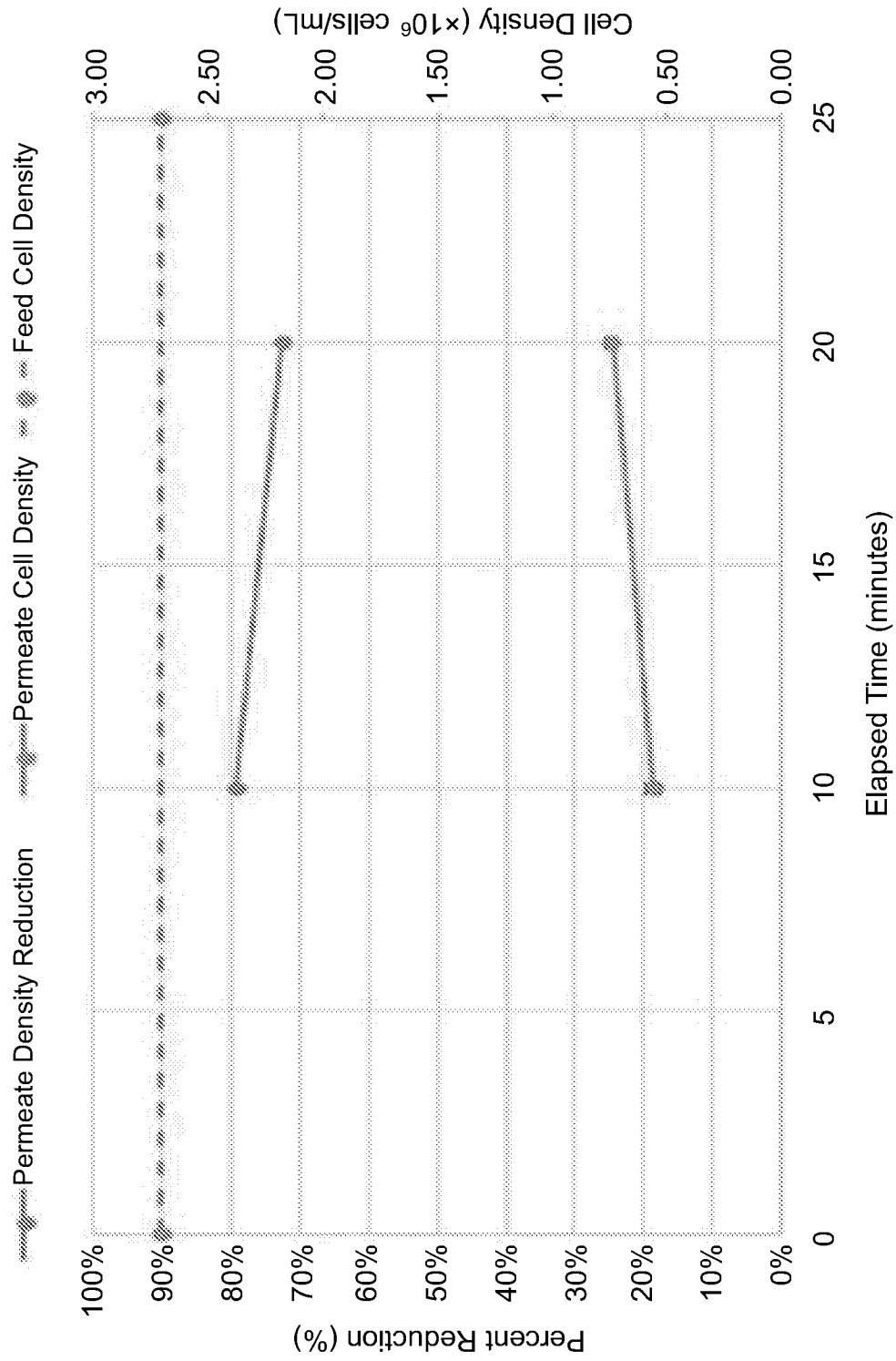

FIG. 16

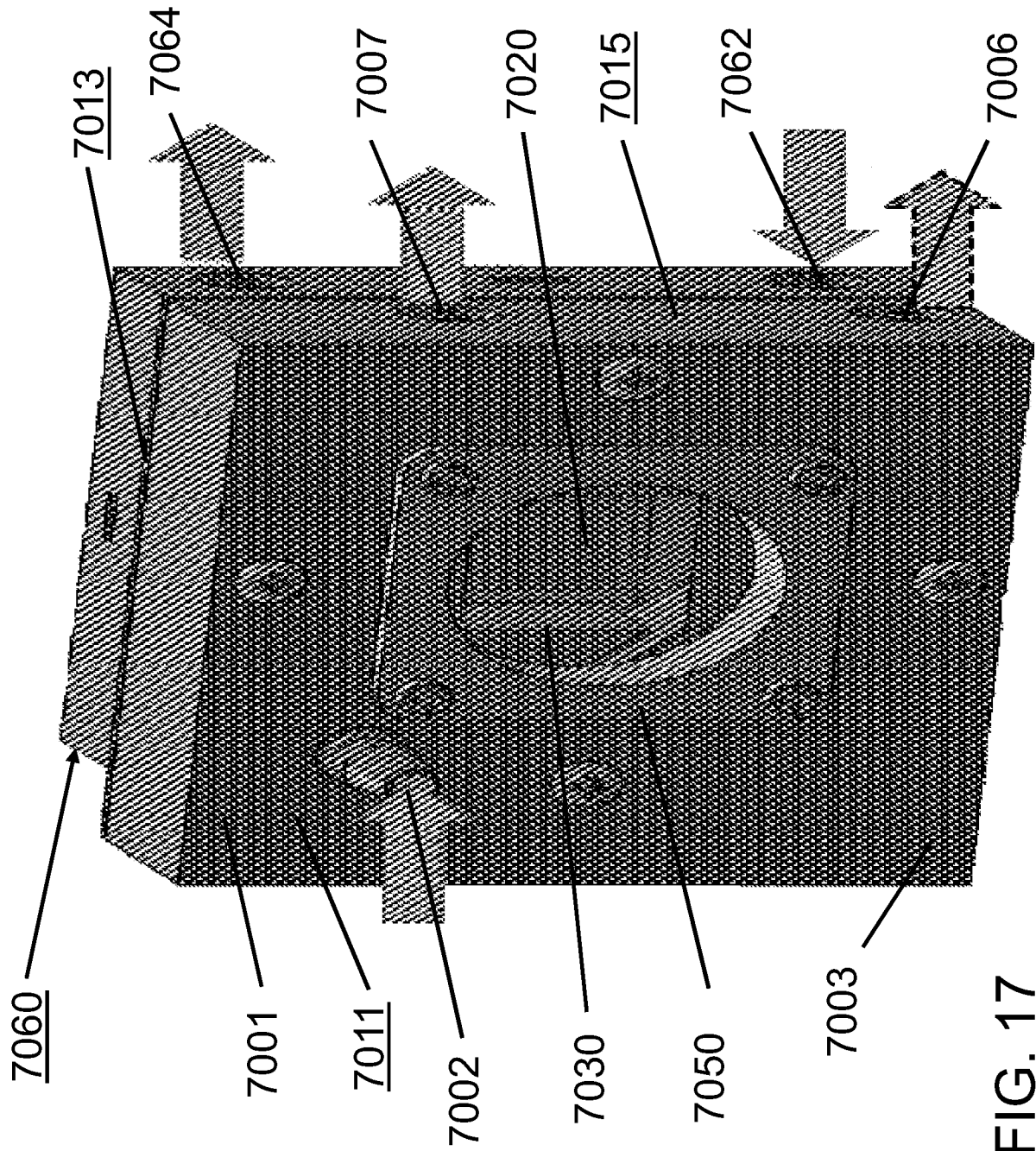

FIG. 17

No Active Cooling – Temperature Profile

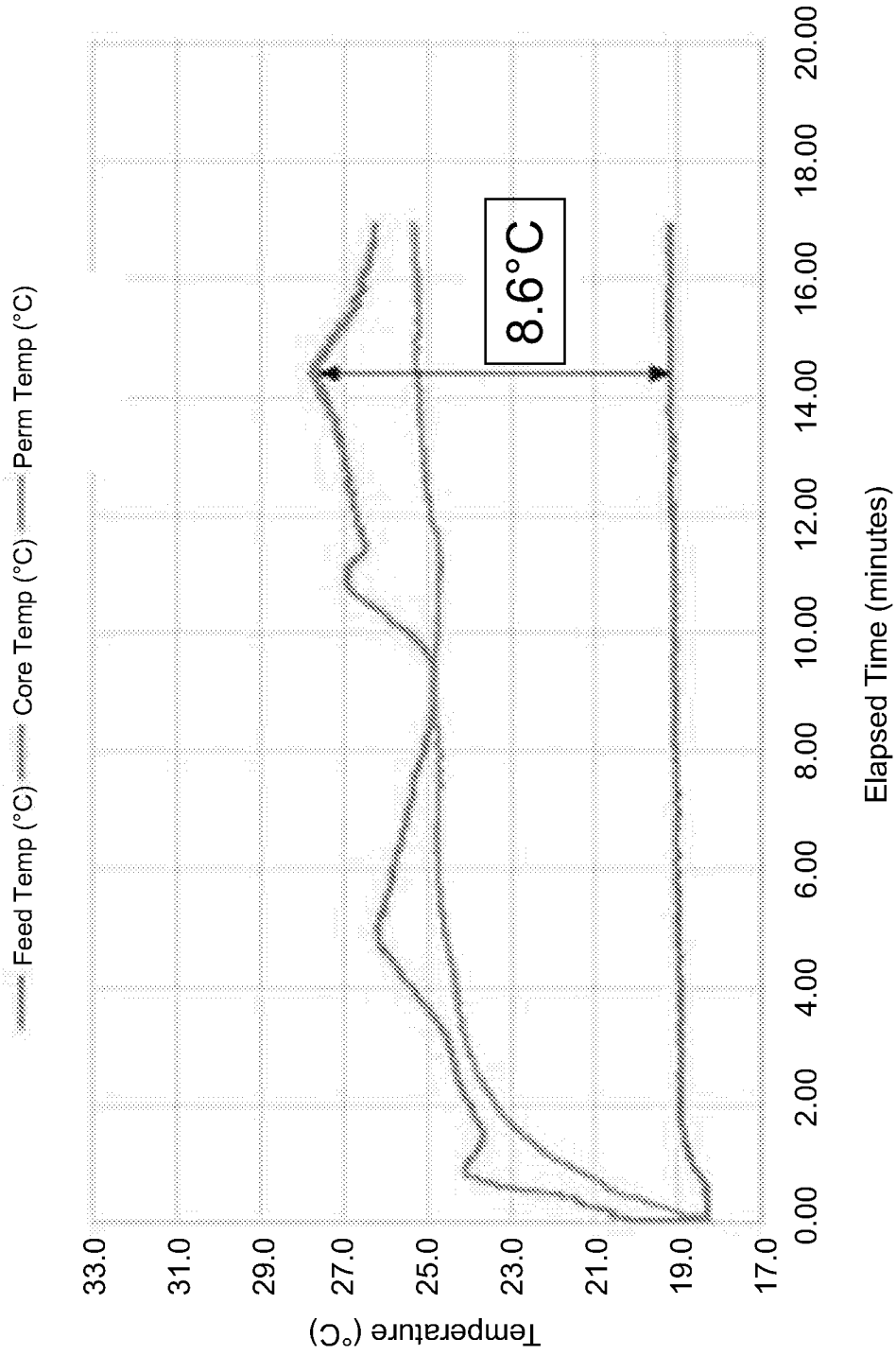

FIG. 18

Active Cooling w/ 5°C Air – Temperature Profile

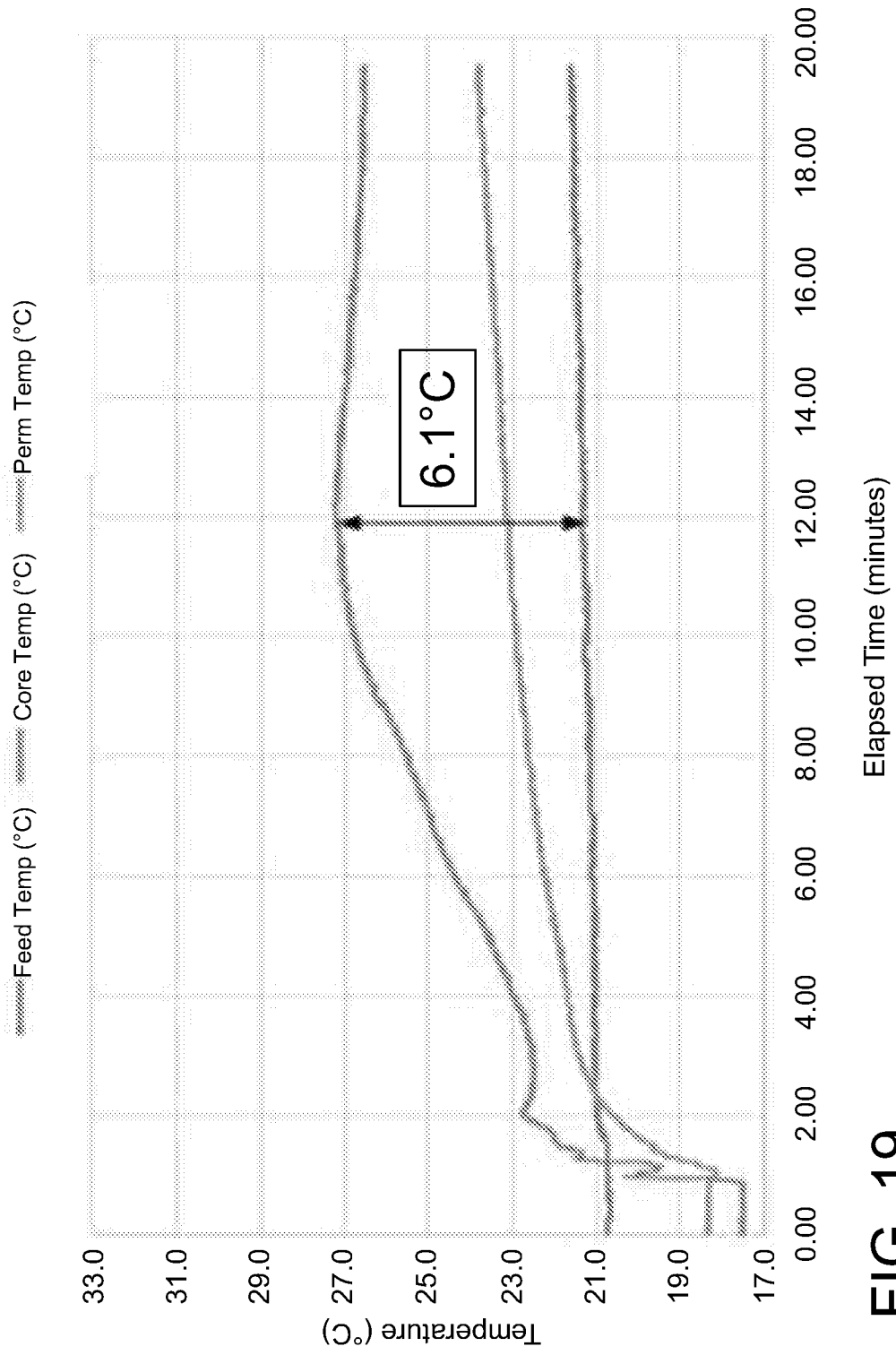
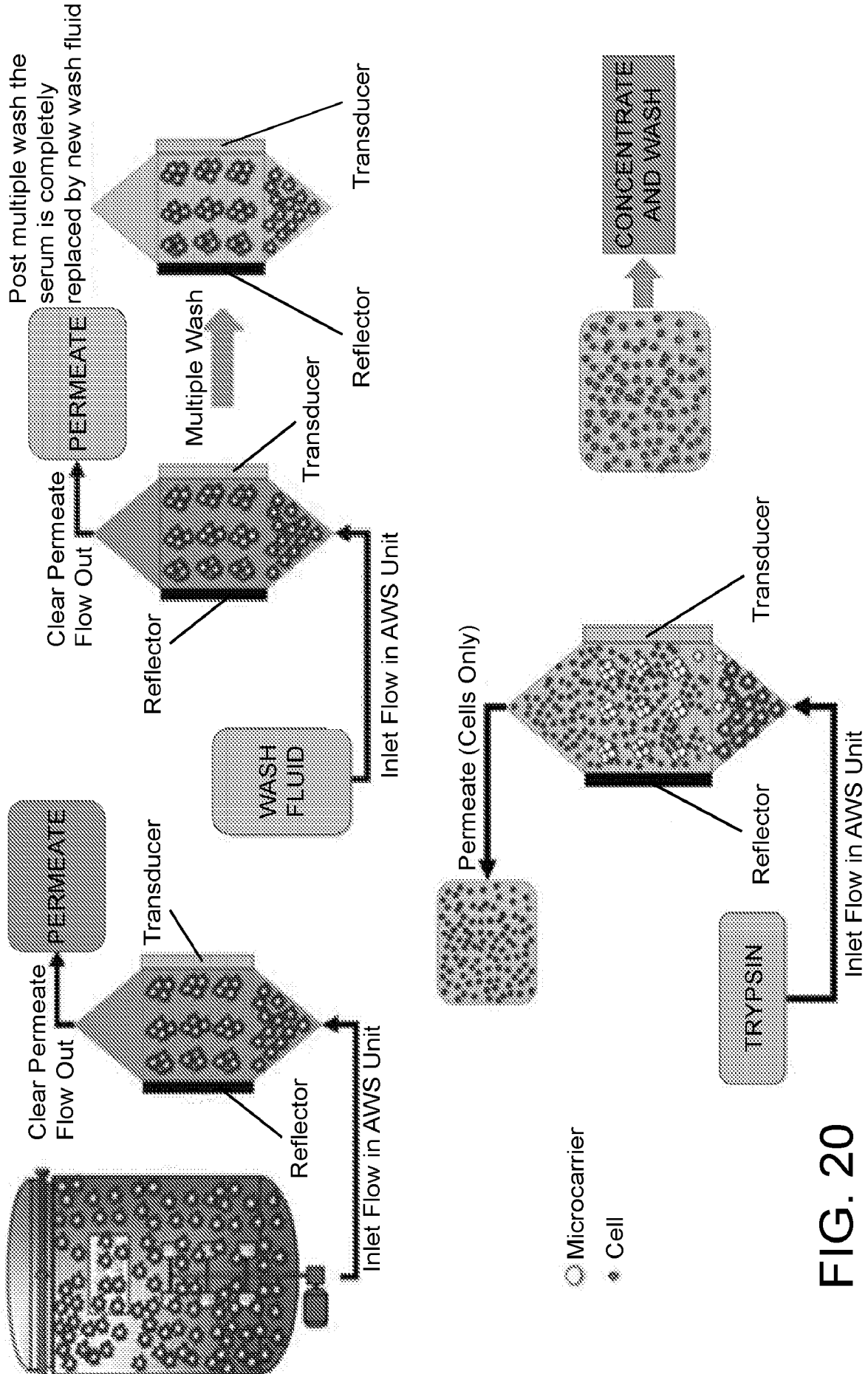

FIG. 19



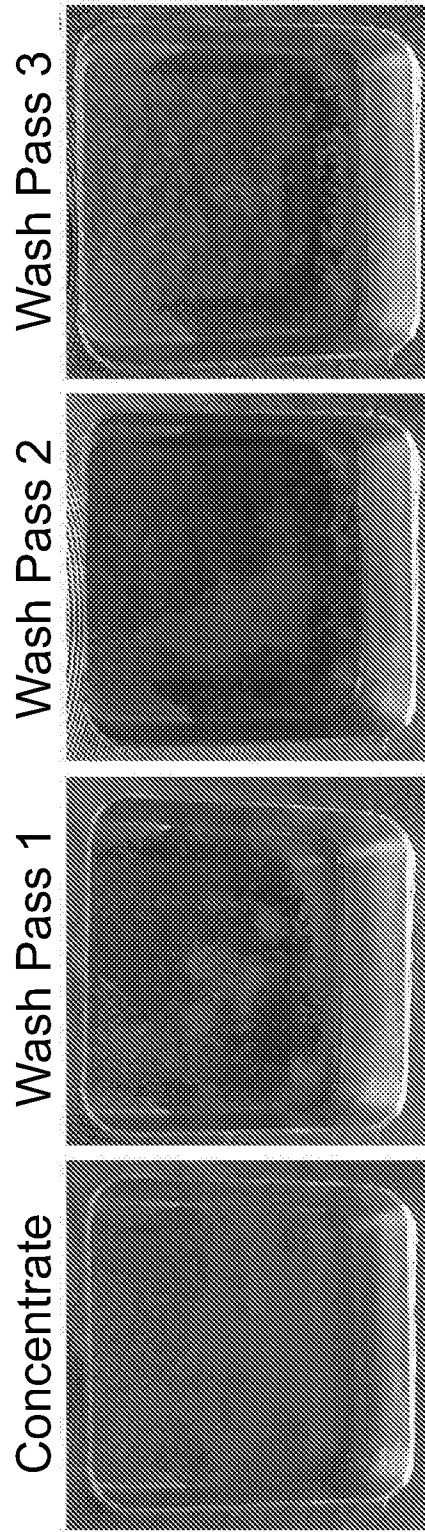
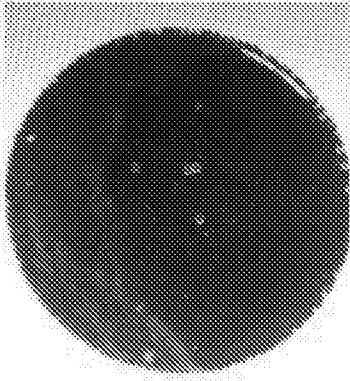
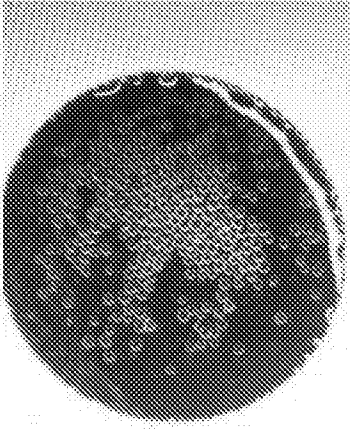

FIG. 21

PERMEATE



FEED



WASH 3

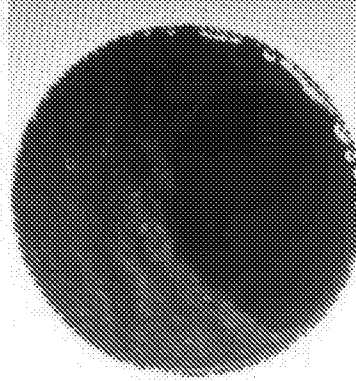

WASH 2

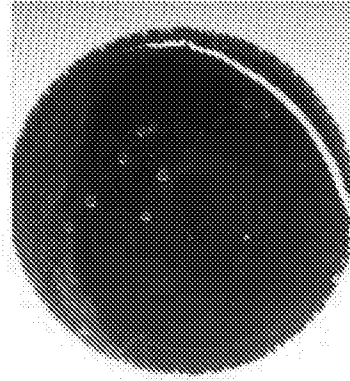

WASH 1

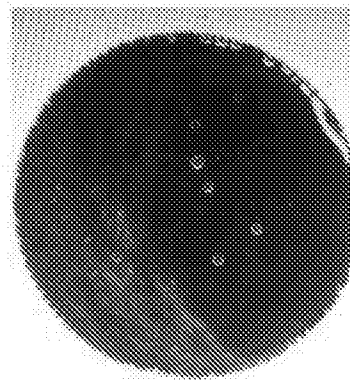

FIG. 22

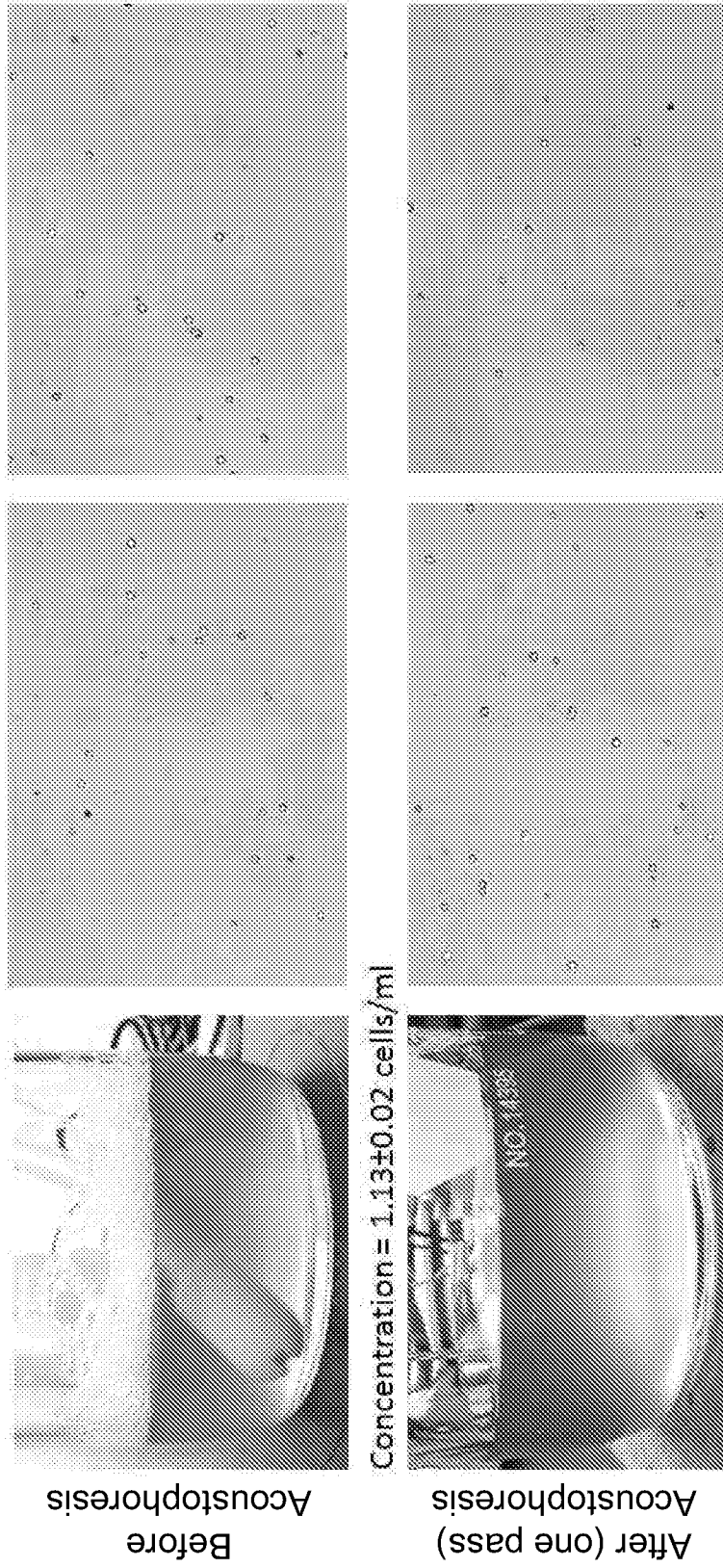

FIG. 23

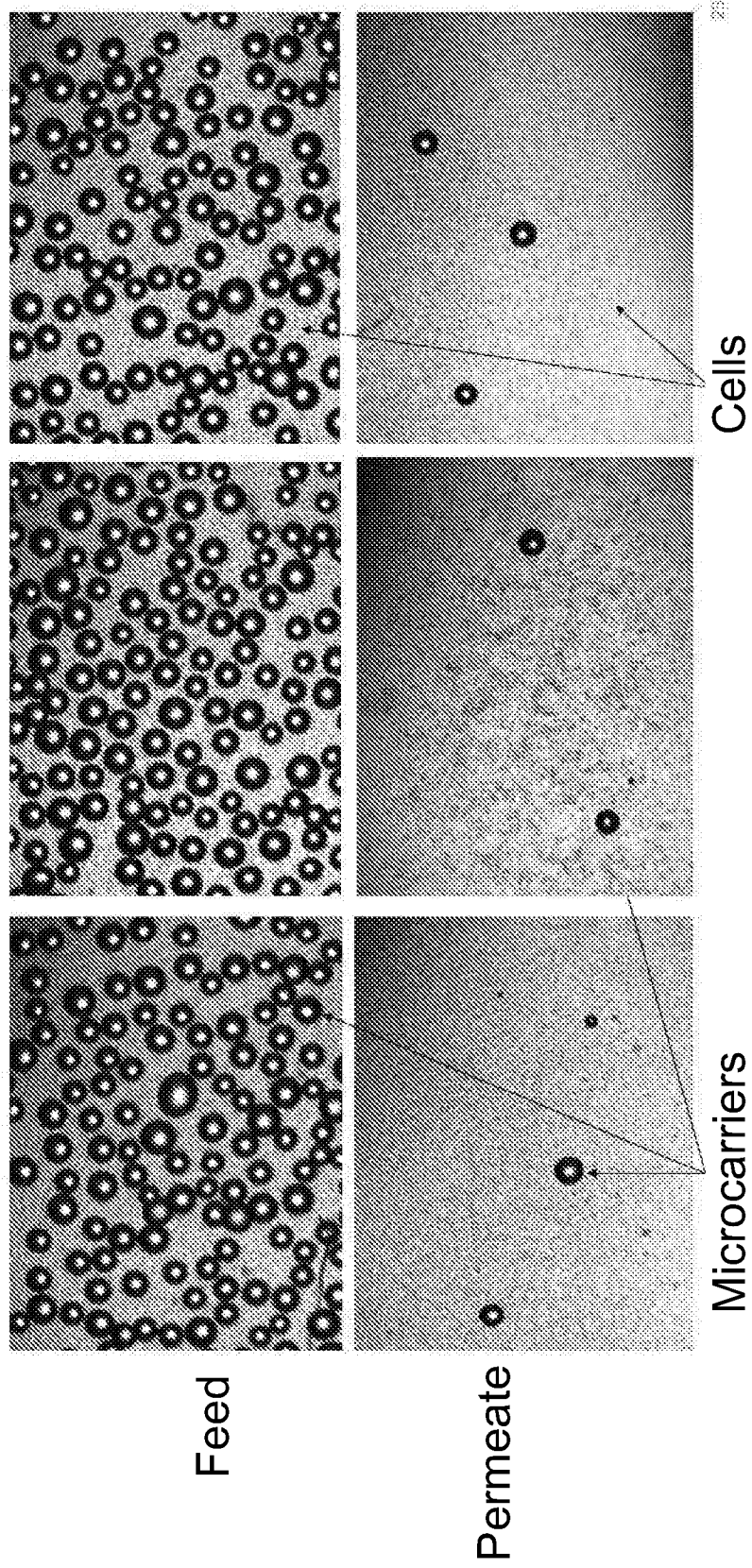

FIG. 24

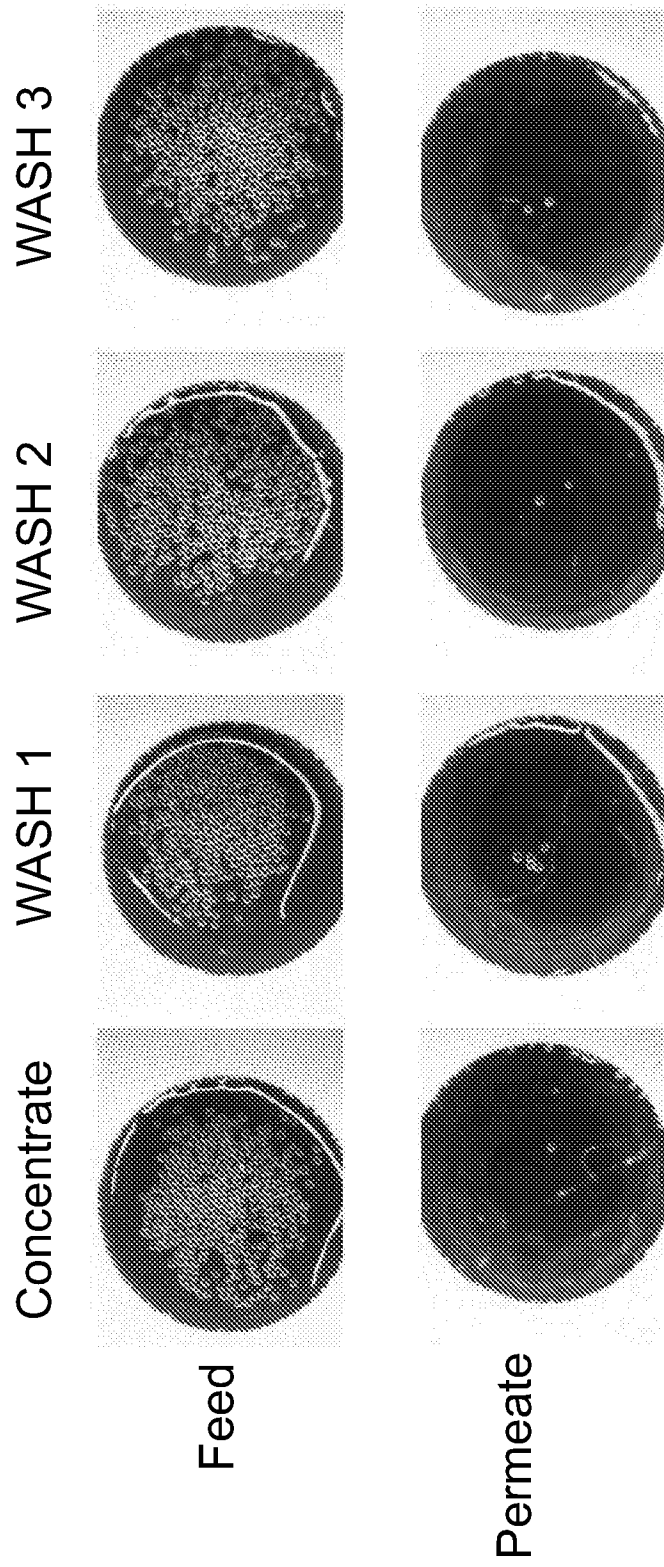

FIG. 25

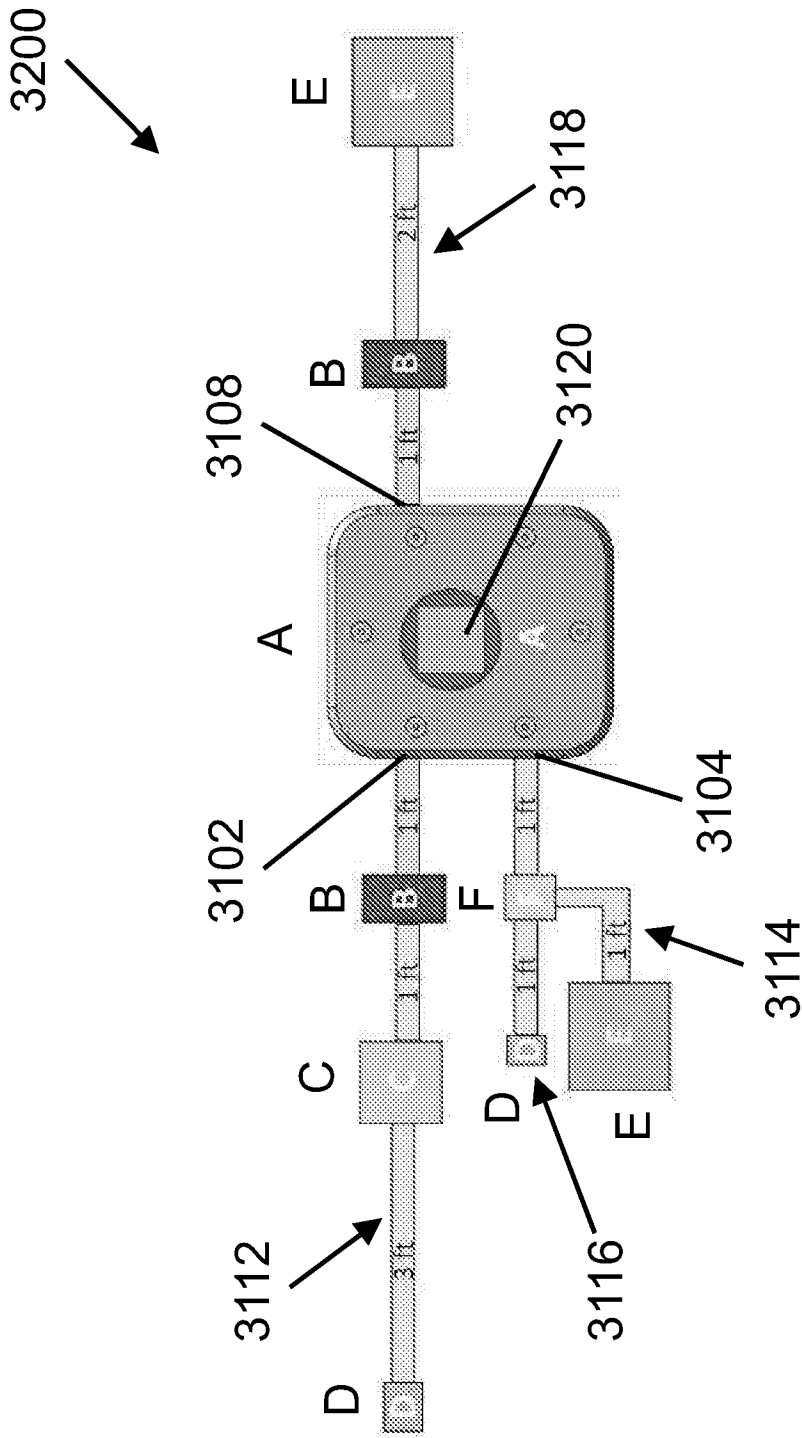

FIG. 27

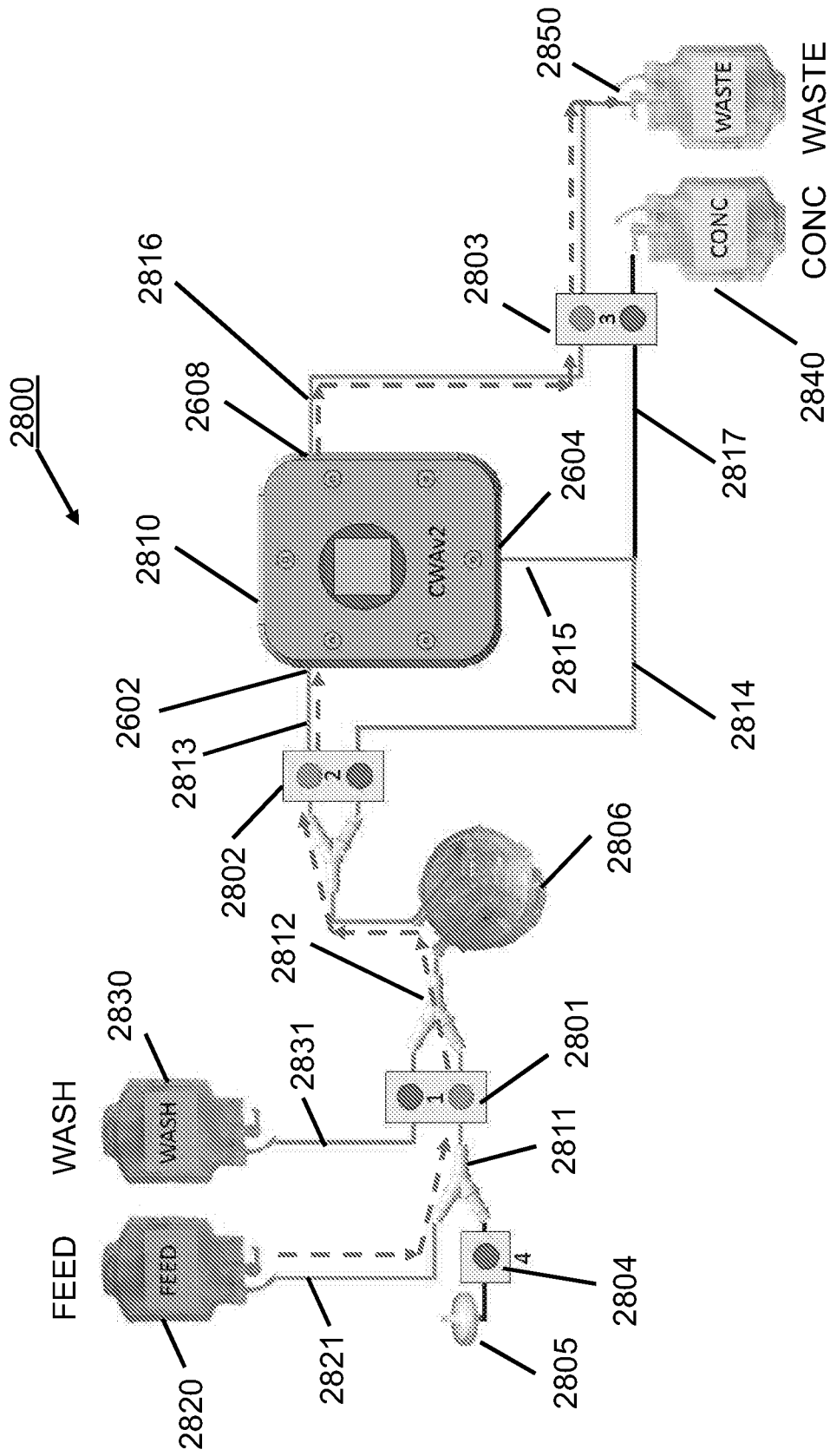

FIG. 28

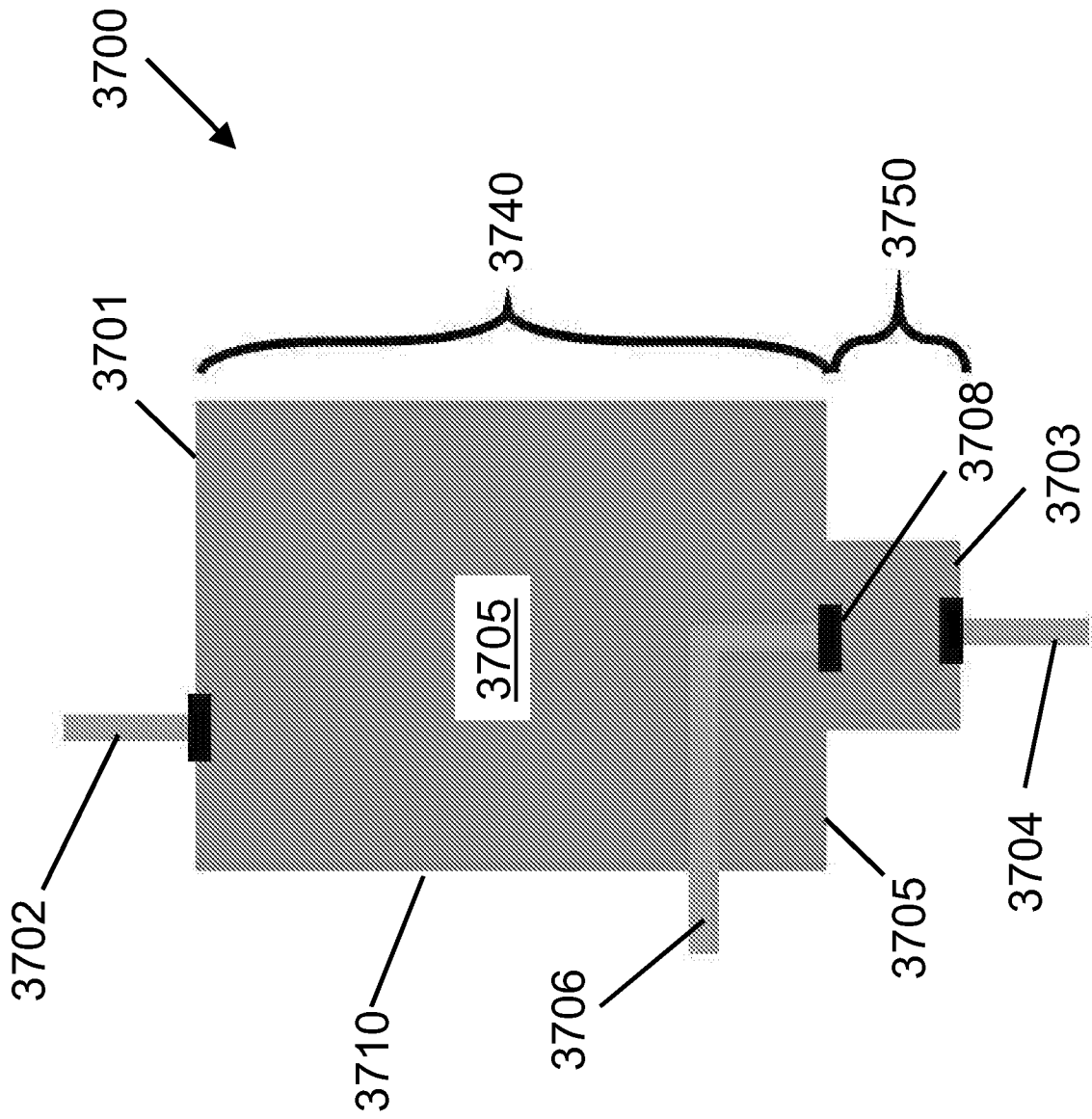

FIG. 31

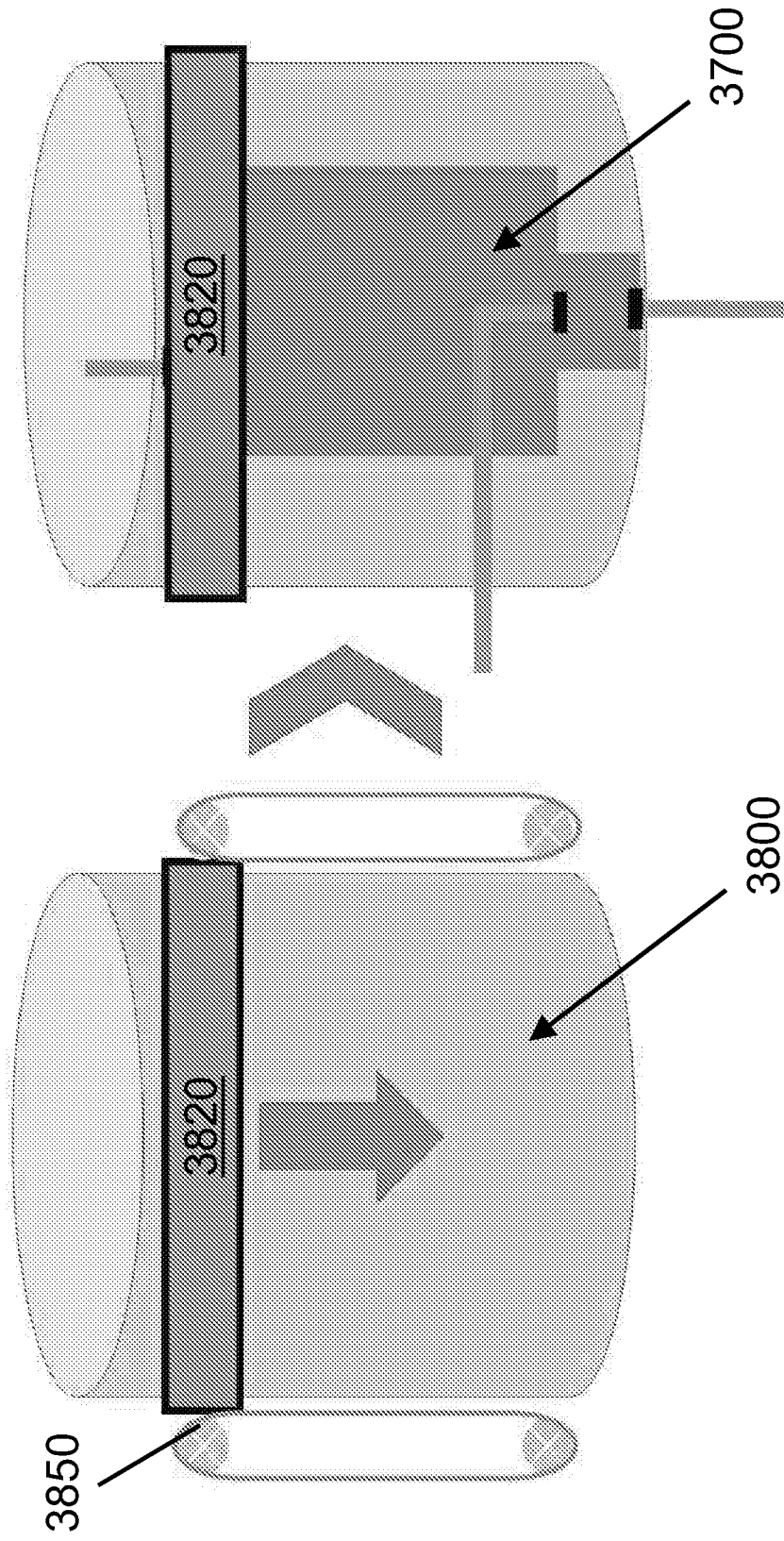

FIG. 32

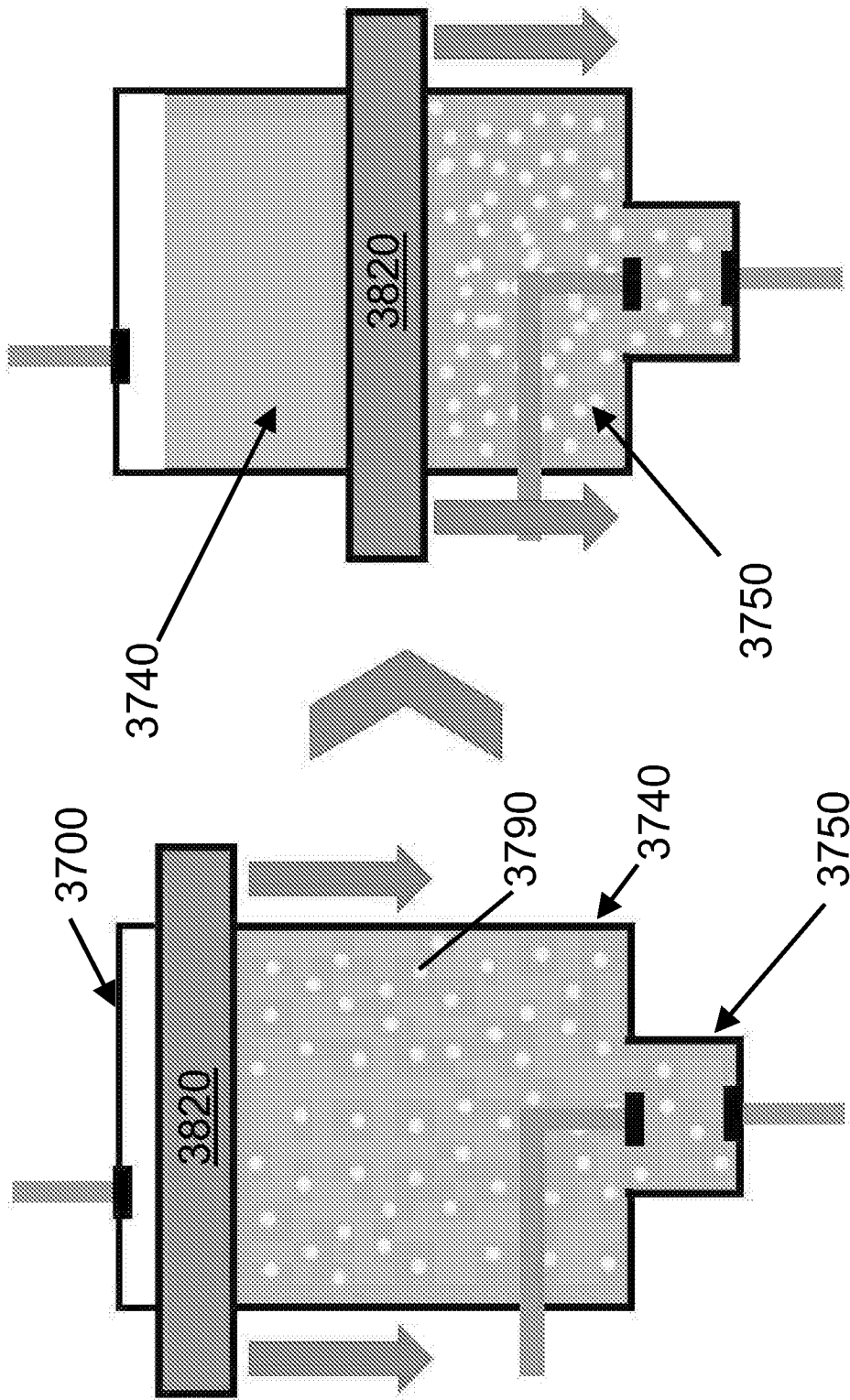

FIG. 33

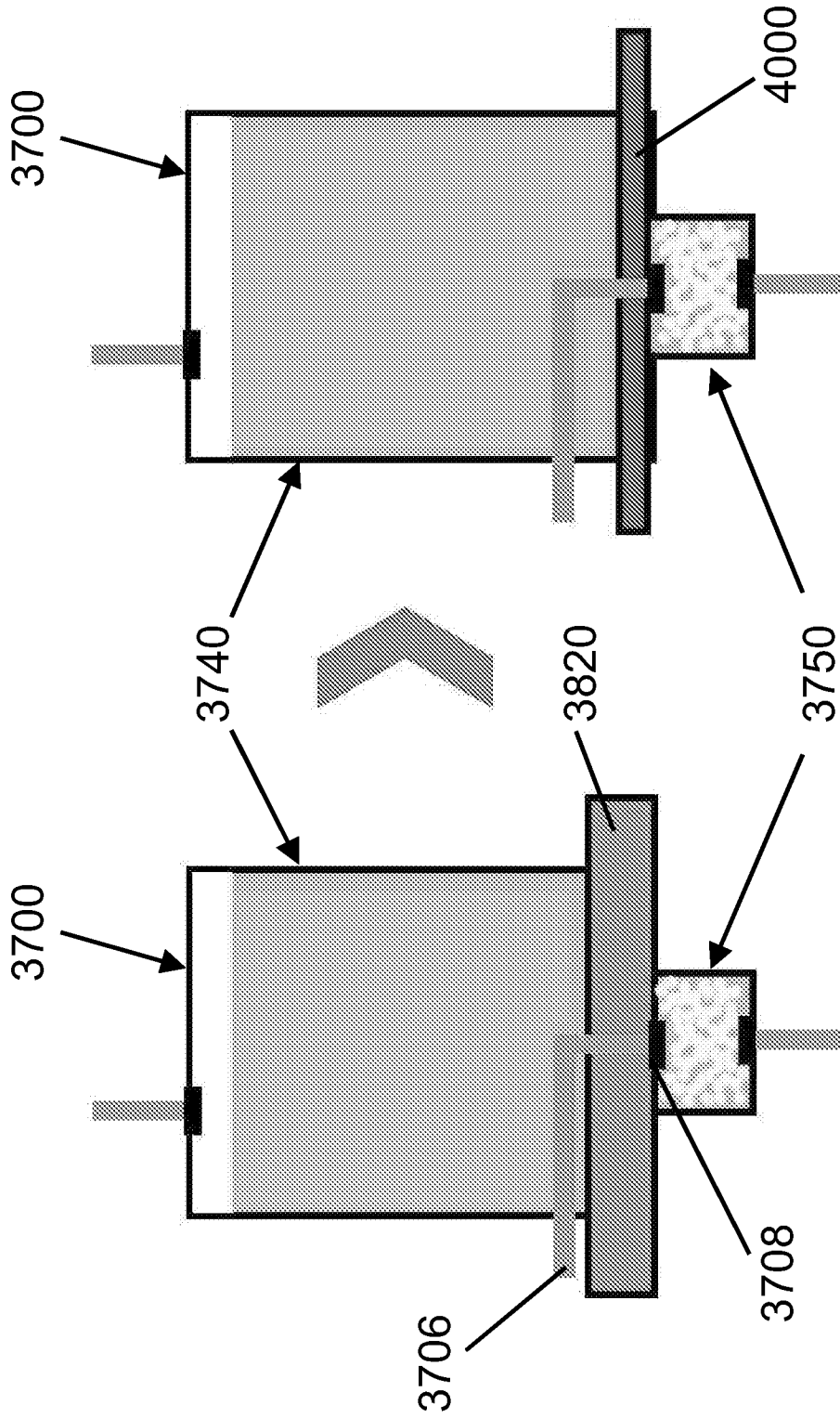

FIG. 34

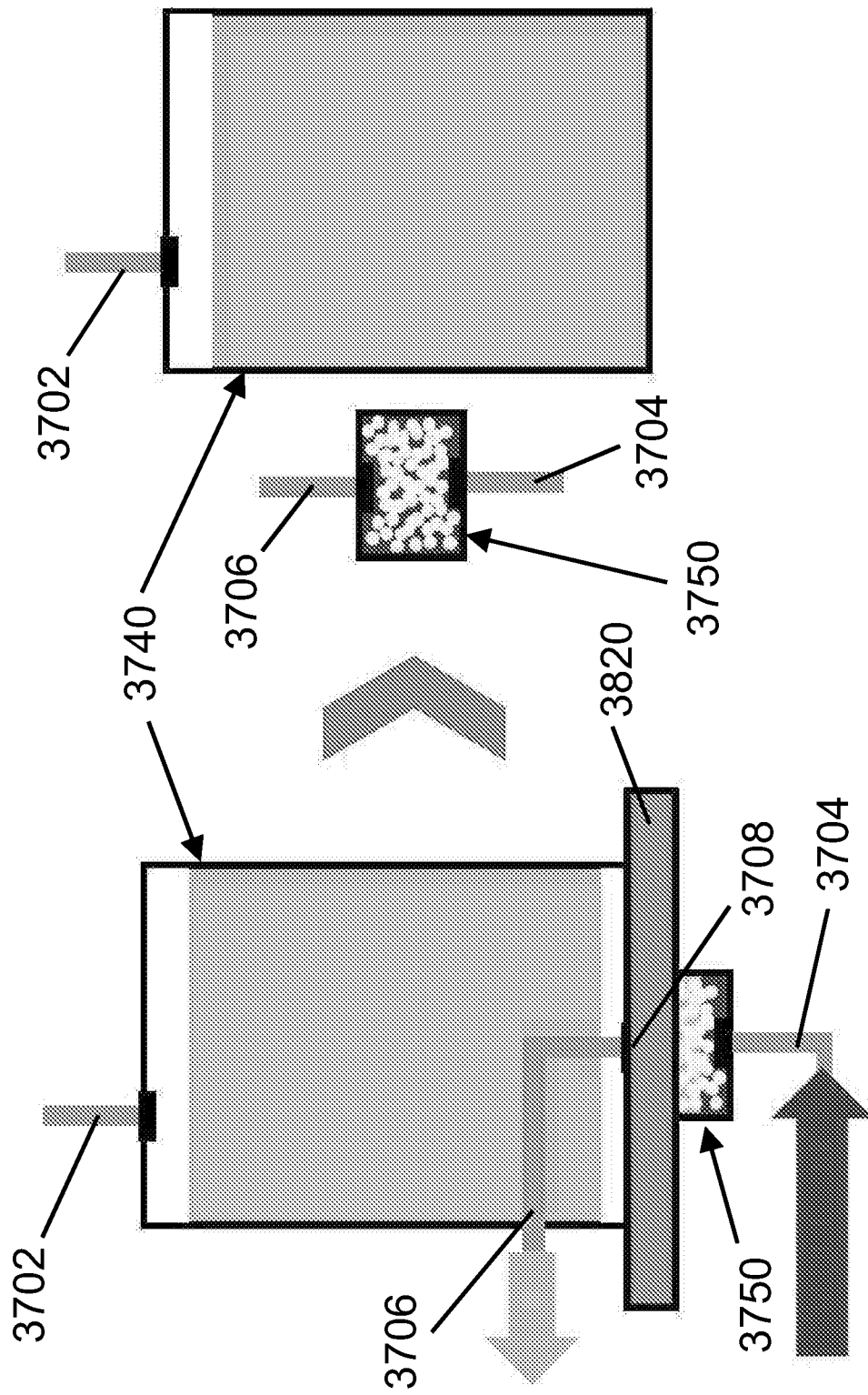

FIG. 35

INTERNATIONAL SEARCH REPORT

International application No
PCT/US2017/030903

A. CLASSIFICATION OF SUBJECT MATTER
 INV. A61J3/00 A61K35/12 A61K35/14 C12N13/00 C12M1/00
 ADD.
 According to International Patent Classification (IPC) or to both national classification and IPC

B. FIELDS SEARCHED
 Minimum documentation searched (classification system followed by classification symbols)
 A61J A61K C12N C12M
 Documentation searched other than minimum documentation to the extent that such documents are included in the fields searched

Electronic data base consulted during the international search (name of data base and, where practicable, search terms used)
 EPO-Internal, BIOSIS, EMBASE, WPI Data

C. DOCUMENTS CONSIDERED TO BE RELEVANT		
Category*	Citation of document, with indication, where appropriate, of the relevant passages	Relevant to claim No.
X	US 2016/102284 A1 (LIPKENS BART [US] ET AL) 14 April 2016 (2016-04-14) [0009], [0085], [0125], [0131], [0018], [0081], [0085] [0108]-[0110], [0148] -----	1-7,9, 10,12, 13,23-27
X	WO 2013/049623 A1 (WARNER BRIAN DAVID [US]; DUNNE JOHN [US]) 4 April 2013 (2013-04-04) [0005], [0008], [0017], [0019], [0026], [0031], [0033], [0041], [0046], [0067], [0015], [0047], [0048], [0050], [0055], [0073], [0057], [0061], [0065], [0077] ----- -/--	1-8, 11-16, 23-27

Further documents are listed in the continuation of Box C.

See patent family annex.

* Special categories of cited documents :

"A" document defining the general state of the art which is not considered to be of particular relevance	"T" later document published after the international filing date or priority date and not in conflict with the application but cited to understand the principle or theory underlying the invention
"E" earlier application or patent but published on or after the international filing date	"X" document of particular relevance; the claimed invention cannot be considered novel or cannot be considered to involve an inventive step when the document is taken alone
"L" document which may throw doubts on priority claim(s) or which is cited to establish the publication date of another citation or other special reason (as specified)	"Y" document of particular relevance; the claimed invention cannot be considered to involve an inventive step when the document is combined with one or more other such documents, such combination being obvious to a person skilled in the art
"O" document referring to an oral disclosure, use, exhibition or other means	"&" document member of the same patent family
"P" document published prior to the international filing date but later than the priority date claimed	

Date of the actual completion of the international search 4 July 2017	Date of mailing of the international search report 13/09/2017
--	--

Name and mailing address of the ISA/ European Patent Office, P.B. 5818 Patentlaan 2 NL - 2280 HV Rijswijk Tel. (+31-70) 340-2040, Fax: (+31-70) 340-3016	Authorized officer Landré, Julien
--	--

INTERNATIONAL SEARCH REPORT

International application No
PCT/US2017/030903

C(Continuation). DOCUMENTS CONSIDERED TO BE RELEVANT		
Category*	Citation of document, with indication, where appropriate, of the relevant passages	Relevant to claim No.
X	<p>PER AUGUSTSSON ET AL: "Acoustophoretic microfluidic chip for sequential elution of surface bound molecules from beads or cells", BIOMICROFLUIDICS, vol. 6, no. 3, 1 September 2012 (2012-09-01), page 034115, XP055386613, US ISSN: 1932-1058, DOI: 10.1063/1.4749289 abstract; figures 1-3, 5 p. 270 col. 1 li. 6-30, p. 271 col. 2 li. 1-18, p. 272 col. 2 li. 1-273 col. 1 li. 12, p. 273 col. 2 li. 15-20, p. 74 col. 2 li. 32-36</p> <p style="text-align: center;">-----</p>	1,2,5,6, 13,23-27
Y	<p>CN 105 087 788 A (SHANGHAI BAIZE MEDICAL APPARATUS AND INSTR CO LTD) 25 November 2015 (2015-11-25) p. 1, 1st , p. 2, 1st-2nd , p. 4, last -p. 5, step F, p. 7, 2nd , p. 10, 4th</p> <p style="text-align: center;">-----</p>	14-16
Y	<p>US 2011/207225 A1 (MEHTA SUNIL [US] ET AL) 25 August 2011 (2011-08-25) [0008], [0012], [0026], [0107], [0116], [0124], [0140]-[0142], [0145]</p> <p style="text-align: center;">-----</p>	14-16
X,P	<p>WO 2016/176663 A1 (FLODESIGN SONICS INC [US]) 3 November 2016 (2016-11-03) the whole document</p> <p style="text-align: center;">-----</p>	1-16, 23-27
X,P	<p>WO 2017/041102 A1 (FLODESIGN SONICS INC [US]) 9 March 2017 (2017-03-09) the whole document</p> <p style="text-align: center;">-----</p>	1-16, 23-27

INTERNATIONAL SEARCH REPORT

International application No.
PCT/US2017/030903

Box No. II Observations where certain claims were found unsearchable (Continuation of item 2 of first sheet)

This international search report has not been established in respect of certain claims under Article 17(2)(a) for the following reasons:

1. Claims Nos.:
because they relate to subject matter not required to be searched by this Authority, namely:

2. Claims Nos.:
because they relate to parts of the international application that do not comply with the prescribed requirements to such an extent that no meaningful international search can be carried out, specifically:

3. Claims Nos.:
because they are dependent claims and are not drafted in accordance with the second and third sentences of Rule 6.4(a).

Box No. III Observations where unity of invention is lacking (Continuation of item 3 of first sheet)

This International Searching Authority found multiple inventions in this international application, as follows:

see additional sheet

1. As all required additional search fees were timely paid by the applicant, this international search report covers all searchable claims.

2. As all searchable claims could be searched without effort justifying an additional fees, this Authority did not invite payment of additional fees.

3. As only some of the required additional search fees were timely paid by the applicant, this international search report covers only those claims for which fees were paid, specifically claims Nos.:

4. No required additional search fees were timely paid by the applicant. Consequently, this international search report is restricted to the invention first mentioned in the claims; it is covered by claims Nos.:

1-16, 23-27

Remark on Protest

- The additional search fees were accompanied by the applicant's protest and, where applicable, the payment of a protest fee.
- The additional search fees were accompanied by the applicant's protest but the applicable protest fee was not paid within the time limit specified in the invitation.
- No protest accompanied the payment of additional search fees.

FURTHER INFORMATION CONTINUED FROM PCT/ISA/ 210

This International Searching Authority found multiple (groups of) inventions in this international application, as follows:

1. claims: 1-16, 23-27

Methods and devices in relation to particles, comprising a chamber of an acoustophoretic device

1.1. claims: 1-13

wherein the method is for washing particles

1.2. claims: 14-16

wherein the method is for separating microcarrier from cells

1.3. claims: 23-27

An acoustophoretic device

2. claims: 17-22

bag and device comprising said bag.

INTERNATIONAL SEARCH REPORT

Information on patent family members

International application No PCT/US2017/030903

Patent document cited in search report	Publication date	Patent family member(s)	Publication date
US 2016102284	A1	14-04-2016	NONE

WO 2013049623	A1	04-04-2013	CN 103906496 A 02-07-2014
			EP 2760413 A1 06-08-2014
			US 2014193381 A1 10-07-2014
			US 2016175198 A1 23-06-2016
			US 2017042770 A1 16-02-2017
			WO 2013049623 A1 04-04-2013

CN 105087788	A	25-11-2015	NONE

US 2011207225	A1	25-08-2011	AU 2009271588 A1 21-01-2010
			AU 2015200830 A1 12-03-2015
			CA 2730528 A1 21-01-2010
			EP 2310486 A2 20-04-2011
			JP 5746025 B2 08-07-2015
			JP 2011528225 A 17-11-2011
			JP 2015180204 A 15-10-2015
			KR 20110031383 A 25-03-2011
			SG 168174 A1 28-02-2011
			SG 192529 A1 30-08-2013
			US 2011207222 A1 25-08-2011
			US 2011207225 A1 25-08-2011
			US 2016137976 A1 19-05-2016
			WO 2010008563 A2 21-01-2010
			WO 2010008579 A2 21-01-2010

WO 2016176663	A1	03-11-2016	US 2016319270 A1 03-11-2016
			WO 2016176663 A1 03-11-2016

WO 2017041102	A1	09-03-2017	NONE
