

J. W. PHILBRICK.
DREDGING-MACHINE.

No. 189,650.

Patented April 17, 1877.

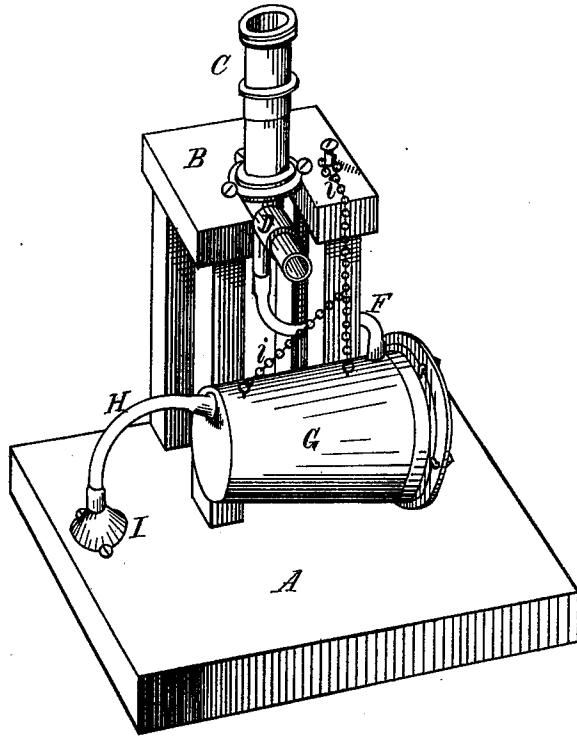

Fig. 1.

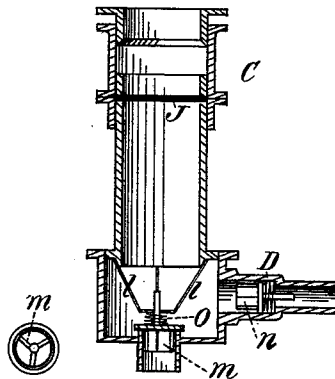

Fig. 2.

Witnesses:
Leroy Sham,
H. C. Metcalf

Inventor:
John W. Philbrick
per C. C. Shaw
Atty

UNITED STATES PATENT OFFICE.

JOHN W. PHILBRICK, OF WATERVILLE, MAINE, ASSIGNOR TO SAMUEL M. PHILBRICK, ISAAC S. BANGS, AND EDWIN R. EMERSON, OF SAME PLACE.

IMPROVEMENT IN DREDGING-MACHINES.

Specification forming part of Letters Patent No. 189,650, dated April 17, 1877; application filed February 8, 1877.

To all whom it may concern:

Be it known that I, JOHN W. PHILBRICK, of Waterville, in the county of Kennebec, State of Maine, have invented certain new and useful Improvements in Dredging-Machines, of which the following is a description sufficiently full, clear, and exact to enable any person skilled in the art or science to which my invention appertains to make and use the same, reference being had to the accompanying drawing, forming a part of this specification, in which—

Figure 1 is an isometrical projection, and Fig. 2 a vertical section, of the pump.

Like letters of reference indicate corresponding parts in the different figures of the drawing.

My invention relates to that class of dredging-machines which are designed more especially for hydraulic mining, or the removal of the precious metals from the beds of rivers, creeks, &c.; and consists in a novel construction and arrangement of the parts, as hereinafter more fully set forth and claimed, by which a simpler, cheaper, and more effective device of this character is produced than is now in ordinary use.

In the drawing, A represents the bed of a river; B, the frame-work in which the pump C is disposed; G, the receiver; F, a flexible pipe connecting the receiver with the pump; *i i*, chains by which the receiver is lowered and hoisted; H, the flexible suction-pipe, which is provided with the bell-shaped induction-nozzle or mouth-piece I. The pump C is provided with a vertically-arranged induction-valve, *m*, the stem of which works in the stays *l l*, and has a coiled spring, O, arranged to act expansively in seating the valve. The eduction-valve *n* is provided with the spring D, and there is a packing, J, for cleaning or wiping the plunger from sand or grit before

it enters the air-packing. The receiver G is in form a hollow conical frustum, having two heads, the pipe H entering the small head, and the pipe F the body of the receiver near the larger head.

In the use of my improvement, the receiver is lowered to the bed of the river or body of water it is desired to dredge by means of the chains *i i*, where it assumes a lateral position, the funnel or bell-shaped mouth I being also directed to fall upon the bed, as shown in Fig. 1. The pump C is then worked, producing a vacuum in the receiver, and causing the material forming the river bottom to be forced, by atmospheric pressure, through the mouth I and pipe H into the receiver, which, when filled, may be raised and discharged, all in a manner which will be readily understood without a more explicit description. The conical form of the receiver causes its induction or smallest end to fall below its eduction or largest end as it strikes the bed of the river, thus leaving the lower end of the pipe F considerably higher than the receiver end of the pipe H, by which the pipe F and pump are prevented to a great extent from clogging before the receiver is sufficiently filled to be elevated. The contents of the receiver may be removed by taking out the large head, which is constructed and arranged in such a manner as to be readily detached from the body.

Having thus explained my improvement, what I claim is—

In a dredging-machine, the combination of the pump C, flexible pipe F, conical receiver G, and flexible pipe H, provided with the nozzle I, when constructed and arranged as and for the purpose set forth and specified.

JOHN W. PHILBRICK. [L. S.]

Witnesses:

GUS. MARSHALL,
C. H. JONES.