



- (51) International Patent Classification:  
A45D 40/26 (2006.01) B65D 53/02 (2006.01)  
B65D 41/04 (2006.01)
- (21) International Application Number: PCT/EP2012/064964
- (22) International Filing Date: 31 July 2012 (31.07.2012)
- (25) Filing Language: English
- (26) Publication Language: English
- (30) Priority Data:  
1157139 4 August 2011 (04.08.2011) FR  
61/527,727 26 August 2011 (26.08.2011) US
- (71) Applicant (for all designated States except US):  
L'OREAL [FR/FR]; 14, rue Royale, F-75008 Paris (FR).
- (72) Inventors; and
- (75) Inventors/Applicants (for US only): DRUGEON, Lionel  
[FR/FR]; 30, rue Voltaire, F-92250 La Garenne Colombes

(FR). LEBRAND, Jean-Marc [FR/FR]; 8 rue Lakanal, F-93500 Pantin (FR).

(74) Agent: FANTIN, Teddy; L'OREAL, D.I.P.I., 25-29 Quai Aulagnier, F-92665 Asnières-sur-Seine Cedex (FR).

(81) Designated States (unless otherwise indicated, for every kind of national protection available): AE, AG, AL, AM, AO, AT, AU, AZ, BA, BB, BG, BH, BN, BR, BW, BY, BZ, CA, CH, CL, CN, CO, CR, CU, CZ, DE, DK, DM, DO, DZ, EC, EE, EG, ES, FI, GB, GD, GE, GH, GM, GT, HN, HR, HU, ID, IL, IN, IS, JP, KE, KG, KM, KN, KP, KR, KZ, LA, LC, LK, LR, LS, LT, LU, LY, MA, MD, ME, MG, MK, MN, MW, MX, MY, MZ, NA, NG, NI, NO, NZ, OM, PE, PG, PH, PL, PT, QA, RO, RS, RU, RW, SC, SD, SE, SG, SK, SL, SM, ST, SV, SY, TH, TJ, TM, TN, TR, TT, TZ, UA, UG, US, UZ, VC, VN, ZA, ZM, ZW.

(84) Designated States (unless otherwise indicated, for every kind of regional protection available): ARIPO (BW, GH, GM, KE, LR, LS, MW, MZ, NA, RW, SD, SL, SZ, TZ, UG, ZM, ZW), Eurasian (AM, AZ, BY, KG, KZ, RU, TJ,

[Continued on next page]

(54) Title: PACKAGING DEVICE PROVIDED WITH A SEALING MEANS

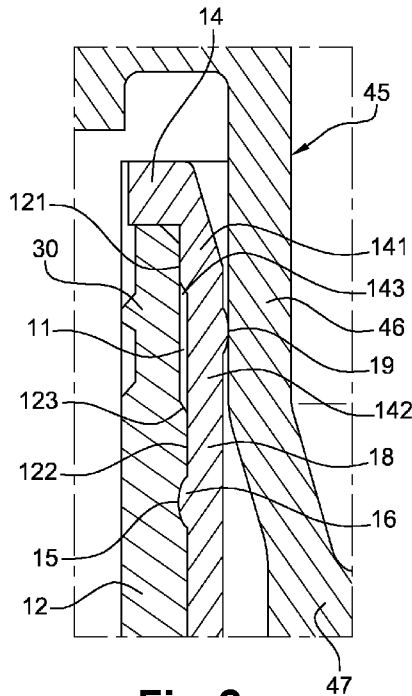

Fig. 2

(57) Abstract: The invention relates to a device(1) for packaging a cosmetic product(P), comprising: • - a container (10) having an opening defined by a neck (12) of the container (10), • - a cap (20) for closing the container (10), • - a closing-off element (45) for the opening, connected to the cap (20), • - a seal (14) mounted in a fixed manner in the neck (12) of the container (10) and able to engage with the closing-off element (45). According to the invention, the device is characterized in that a portion of the seal is not in contact with the neck so as to form a free volume (11) between the outer wall of the seal (14) and the inner wall of the neck (12).

TM), European (AL, AT, BE, BG, CH, CY, CZ, DE, DK, EE, ES, FI, FR, GB, GR, HR, HU, IE, IS, IT, LT, LU, LV, MC, MK, MT, NL, NO, PL, PT, RO, RS, SE, SI, SK, SM, TR), OAPI (BF, BJ, CF, CG, CI, CM, GA, GN, GQ, GW, ML, MR, NE, SN, TD, TG). **Published:** — *with international search report (Art. 21(3))*

## PACKAGING DEVICE PROVIDED WITH A SEALING MEANS

The present invention relates to a device for packaging a cosmetic product.

The invention relates more particularly to a device for packaging a  
5 cosmetic product provided with a sealing means.

The expression "cosmetic product" is understood to mean any product as defined in Regulation (EC) No 1223/2009 of the European Parliament and Council of 30 November 2009 relating to cosmetic products.

A cosmetic product is generally packaged in a container closed by a  
10 cap screwed onto this container. Thus, pots that contain for example a care cream and have a closing lid screwed onto the pot are known. Also known are packaging devices that comprise a container and a cap, comprising an applicator fixed to the cap and extending into the container, the cap thus serving as a member for grasping the applicator. This is the case particularly for  
15 mascara.

In this type of packaging, the contents are generally sealed off from outside air, for example for better preservation of the product, by means of a seal compressed in the direction of the axis of the opening, between the upper edge of the neck defining the opening in the container and the cap. In other  
20 cases, impermeability is obtained in any case by means of a component of the compressive force in the direction of the axis of the opening, for example by cone-on-cone contact.

One drawback of this type of packaging is that a large pressure force on the seal is required in order to ensure sufficient impermeability. This force is  
25 obtained by the screwing of the cap onto the container. However, the screw closure imposes a circular shape on the parts to be joined together, thereby constraining the design and/or limiting the possibilities of developing these devices.

Finally, the quality of impermeability brought about by compression of  
30 this type of packaging device depends on the screwing force. Thus, when the cap is not screwed sufficiently or in the event of accidental unscrewing, the quality of impermeability decreases, or even disappears, and this can cause

leaks of product towards the outside. This is particularly the case for the device disclosed in document WO2010/125758.

Document FR2932067 proposes a device comprising a container for a cosmetic product and a closing stopper that engages on the container by screwing. The closing stopper is equipped with a movable applicator that is acted on axially by a spring means housed in the stopper such that a conical closing-off element of the applicator comes into contact with a likewise conical seal fitted on the container.

However, because this mechanism comprises a large number of components, it is expensive and complex to produce. Moreover, the impermeability brought about by the pressure force of the spring at the point of contact between the closing-off element and the seal varies depending on the movement of the stopper with respect to the container.

The object of the present invention is thus to provide an improved device for packaging a cosmetic product in order to alleviate the abovementioned drawbacks.

To this end, the invention proposes a device for packaging a cosmetic product, comprising:

- a container having an opening defined by a neck of the container,
- a cap for closing the container,
- a closing-off element for the opening, connected to the cap,
- a seal mounted in a fixed manner in the neck of the container and able to engage with the closing-off element.

According to the invention, the device is characterized in that a portion of the seal is not in contact with the neck so as to form a free volume between the outer wall of the seal and the inner wall of the neck.

One of the advantages is to ensure constant impermeability in spite of a variation in the relative positioning height of the closing-off member with respect to the seal, and in spite of the variations in dimensions of the various elements.

According to further features of the invention, the inner face of the seal may have an annular bulge that engages with the closing-off element, said annular bulge being positioned at the free volume.

The cap may be moved from its locked position to its unlocked  
5 position by the cap moving purely in translation with respect to the container.

The contact between the seal and the closing-off element may be only radial with respect to the axis of the opening in the container.

The closing-off element may comprise an applicator which extends from the cap into the container, and the seal may comprise a portion for wiping  
10 the applicator.

The invention will be understood better from reading the following description of non-limiting examples of the implementation thereof with reference to the appended drawings, in which:

- Figure 1 shows a sectional view of an example of a packaging device  
15 comprising a sealing assembly according to the invention;
- Figure 2 shows a detail view of the sealing assembly of the device from Figure 1;
- Figure 3 shows a second example of a device comprising a sealing assembly according to the invention;
- 20 - Figure 4 shows a sectional view of the device from Figure 3.

With reference to Figures 1 to 4, a device 1 for packaging a cosmetic product P comprises a container 10 for containing said product P, a cap 20 for closing the container 10 and a locking mechanism 30 for keeping the cap 20 on  
25 the container 10.

In these examples, the device 1 is a device for packaging and applying mascara, but the invention is not limited to this type of packaging. The invention may also relate to devices for packaging other cosmetic products P such as foundation, nail varnishes, lipsticks, lip glosses or care products, such  
30 as a concealer, for example.

In the example shown in Figures 1 and 2, the container 10 and the cap 20 of the device 1 have circular cross sections.

The container 10 is a hollow body that extends mainly along a longitudinal axis X-X, is closed at one end by an end wall, and is open at the other end. The opening in the container 10 is defined by a neck 12 that extends from a shoulder of the container 10. In this example, the neck 12 has a circular cross section and has a thread that forms the locking mechanism 30.

The container 10 may for example be made of glass, metal or plastic.

A seal 14 is fixed in the opening defined by the neck 12 of the container 10. In the case of a container containing a product of the mascara type, the seal 14 also provides the function of wiping an applicator 40. To this end, the seal 14 may also be called a wiper.

The seal may be made of a material selected from elastomeric rubbers and thermoplastics. The material could, for example, be selected from among silicones, nitriles, natural or synthetic latices, EPDMs, polyurethanes, blends of polypropylene and SBS, SEBS, or EPDM, natural, synthetic or thermoplastic elastomers, in particular copolymers of polypropylene and of SEBS, styrene-butadiene or ethylene-vinyl acetate copolymers, polyethylenes, nitrile rubbers, polychloroprene or neoprene, ethylene propylene diene terpolymers (EPDMs), butadiene-acrylonitrile copolymers, polyurethanes, plasticized polyvinyl chlorides, crosslinked rubbers, in particular those based on silicone, or any other material suitable for obtaining sufficient impermeability.

The seal 14 is approximately tubular and is engaged at least partly with a tight fit against the inner wall of the neck 12 so as to form cylindrical impermeability between the seal 14 and the neck 12 of the container 10. The seal 14 may comprise an upper edge intended to come into axial contact with the upper peripheral rim of the neck 12.

In addition, as can be seen in Figure 2, the seal 14 may comprise an external annular boss 16 which is engaged in an internal annular groove 15 in the neck 12 in order to axially retain the seal 14 in the neck 12.

In order to provide the wiping function, the lower end of the seal 14 is formed with a frustoconical wall 17 which is flared from bottom to top so as to define a through-orifice towards the inside of the container, said orifice being narrower than the opening in the neck 12.

According to the invention, the upper part 18 of the seal 14 is approximately cylindrical and has a portion that is not in contact with the inner wall of the neck 12 so as to form a free volume 11 between the seal 14 and the neck 12 of the container 10. As shown on Figure 2, the free volume 11 is a closed volume which does not communicate with the interior of the container. This closed volume is defined on one hand, by the seal 14 and, on the other hand by the neck 12 of the container 10. To this end, the inner wall of the neck 12 has an upper portion 121 having a greater diameter than its lower portion 122, the two portions 121 and 122 being separated by a shoulder 123 such that the upper portion 121 is set back towards the outside with respect to the lower portion 122. The upper part 18 of the seal 14 also has an upper portion 141 of its outer wall, having a greater diameter than its lower portion 142, the two portions 141 and 142 of the seal 14 being separated by a shoulder 143 such that the upper portion 141 is set back towards the outside with respect to the lower portion 142. The outside diameter of the upper portion 141 of the seal 14 is approximately the same as the inside diameter of the upper portion 121 of the wall of the neck 12, such that these are in contact with one another. Similarly, the outside diameter of the lower portion 142 of the seal 14 is approximately the same as the inside diameter of the lower portion 122 of the wall of the neck 12, likewise such that these are in contact so as to provide impermeability between the neck 12 and the seal 14.

When the seal 14 is positioned in the neck 12, the shoulder 123 of the inner wall of the neck 12 is located lower than the shoulder 143 of the outer wall of the seal 14, such that there is an annular empty volume 11 between these two shoulders 123 and 143. Thus, the seal 14 and the neck 12 are not in contact at this volume 11, and define a closed volume 11.

The above-described arrangement is not limiting and the free volume can of course be produced by any other arrangement of the seal 14 with respect to the neck 12. For example, the inner wall of the neck may be cylindrical and the seal may have a cylindrical portion comprising an annular external groove that forms the free volume.

The inner wall of the seal has an annular bulge 19 at the empty volume.

The cap 20 of the device 1 is a hollow body that extends mainly along the longitudinal axis X-X of the container 10, is closed at one end by an end wall and is open at the other end so that it can be positioned around the neck 12 of the container 10. For this purpose, the height of the cap 20 is greater than the height of the neck 12.

The cap may be produced from metal, glass, plastic or any other material.

10 An insert 21 is fixed in a non-removable manner in the cap 20. The insert 21 comprises a tubular hollow body 22 fitted into the cap 20. The insert 21 may be fixed in a non-removable manner in the cap 20 by any appropriate means, for example by adhesive bonding, with a tight fit or by snap-fastening.

15 The lower part of the insert 21, that is to say the part closest to the open end of the cap 20, comprises a thread complementary to the thread on the neck 12, such that the cap 20 can be locked on the container 10 by screwing.

The insert 21 also comprises an element 45 for closing off the opening in the container 10. The closing-off element is connected to the tubular body of the insert by a plate 23.

20 The closing-off member 45 comprises a cylindrical wall 46 that is positioned in contact with the inner faces of the tubular portion of the seal 14 when the cap 20 is in the locked position on the container 10.

25 In order to obtain optimum contact to form impermeability at the neck 12 of the container 10, between the seal 14 and the closing-off element 45, the cylindrical wall 46 engages with the annular bulge 19 on its periphery, as is shown in Figure 2.

30 The seal 14 is thus deformed easily towards the outside into the empty volume 11 between the seal 14 and the wall of the neck 12. The contact between the seal 14 and the closing-off element 45 does not have a component along the axis X-X and thus occurs only radially with respect to the longitudinal axis X-X.

In a variant which is not shown, the cylindrical wall 46 may comprise an annular bead and the seal does not then have a bulge, the annular bead being positioned in contact with the seal at the empty volume 11 so as to deform the seal into the empty volume.

5           The impermeability thus obtained is impermeability to gas and to liquid. More precisely, the device remains impermeable, that is to say that no leakage of product to the outside of the device is observable, when the device is placed in the locked position in a vacuum bell in order to be subjected to reduced pressure while the pressure inside the container 10 containing  
10       cosmetic product, such as mascara, is approximately equal to the atmospheric pressure of around 1 bar. The impermeability of the device is preserved down to a pressure in the bell, outside the device, of less than 0.3 bar, or even less than 0.25 bar, for example 0.2 bar.

          Moreover, the device remains impermeable at atmospheric pressure  
15       as long as the closing-off element 45 is in contact with the annular bulge 19, that is to say even while the cap 20 is being unscrewed. The force for removing the closing-off element 45 from the neck of the container 10 is greater than the weight of the container 10 filled with product P. For example, this removing force is greater than 1 Newton or even greater than 2 Newtons.

20           In this example, a wand 47 extends longitudinally along the axis X-X starting from the closing-off element 45. The end of the wand 47 is provided with an applicator element 48 for example of the mascara brush type. Thus, when the closing-off element 45 closes the opening in the container 10, the wand 47 and the applicator element 48 are dipped into the container 10. The  
25       cap 20 and the closing-off element 45 thus form a cosmetic product applicator 40.

          The wand 47, the closing-off element 45, the plate 23 and the tubular part 22 of the insert 21 may be formed integrally.

30           In the second example, shown in Figures 3 and 4, of a device comprising a sealing assembly according to the invention, the container 10, the locking mechanism 30 and the cap 20 of the device 1 have non-circular cross sections, in particular approximately square cross sections in this example.

However, other cross sections of the device 1 are conceivable, such as polygonal, ovoid, circular or other cross sections.

The container 10 is a hollow body that extends mainly along a longitudinal axis X-X. The opening in the container 10 is defined by a neck 12  
5 having a circular cross section, but it could have a different cross section.

The neck 12 may have a narrowing 13 located between the container and the upper rim of the neck 12.

A seal 14 similar to the one described for the previous device is fixed in the opening defined by the neck 12 of the container 10. The inside wall of the  
10 neck 12 is also designed, as in the previous example, to form an empty annular volume 11 between the seal 14 and the neck 12, as can be seen in Figure 2.

The mechanism 30 for locking the cap 20 on the container 10 comprises a hoop 31 and an elastic ring 36 which are fitted around the neck 12 of the container 10. The hoop 31 of the locking mechanism 30 is fixed to the  
15 neck of the container 10, keeping the ring 36 around the neck 12.

The elastic ring 36 comprises an actuating means 37, such as a push button, placed in an opening 35 in the hoop 31. The elastic ring 36 also comprises a retaining means 38. This retaining means 38 is intended to lock the  
20 cap 20 on the container 10. The retaining means 38 forms for example a catch positioned in a window 34 in the hoop 31.

When the user exerts a pressure on the actuating means 37, the ring 36 is deformed and the retaining means 38 moves towards the neck 12. When the pressure on the actuating means 37 is released, the elastic ring 36 returns  
25 to its rest position.

The cap 20 of the device 1 is a hollow body that extends mainly along the longitudinal axis X-X of the container 10, is closed at one end by an end wall and is open at the other end so that it can be positioned around the neck 12 of  
the container 10. For this purpose, the height of the cap 20 is greater than the height of the neck 12.

30 The cap may be produced from metal, glass, plastic or any other material.

An insert 21 is fixed in a non-removable manner in the cap 20. The insert 21 is a tubular hollow body fitted into the cap 20. In this example, the cross section of the insert 21 is approximately square, but this cross section may have any other shape, depending on the cross section of the cap 20.

5           The insert 21 may be fixed in a non-removable manner in the cap 20 by any appropriate means, for example by adhesive bonding, with a tight fit or by snap-fastening.

          The lower part of the insert 21, that is to say the part closest to the open end of the cap 20, comprises an opening that opens at least onto the inner  
10 wall of the insert 21. This opening defines a catching means 23 for the means 38 for retaining the locking mechanism 30.

          A closing-off element 45 for the opening in the container 10 is mounted in a sliding manner with respect to the insert 21 and thus with respect to the cap 20.

15           The closing-off member 45 comprises a cylindrical wall 46 that is positioned in contact with the inner faces of the tubular portion 18 of the seal 14, so as to function like the arrangement in the previous example.

          In this example, a wand 47 extends longitudinally along the axis X-X starting from the closing-off element 45. The end of the wand 47 is provided  
20 with an applicator element 48 for example of the mascara brush type. Thus, when the closing-off element 45 closes the opening in the container 10, the wand 47 and the applicator element 48 are dipped into the container 10. The cap 20 and the closing-off element 45 thus form a cosmetic product applicator 40.

25           The device 1 comprises a spring member 50 located between the cap 20 and the upper part 41 of the closing-off element 45 so as to generate a force that tends to push these two elements away from one another along the longitudinal axis X-X. The spring member 50 may be a helical spring mounted in compression between the cap 20 and the upper part 41 of the closing-off  
30 element 45, more precisely between the insert 21 and the plate of the upper part 41 of the closing-off element 45.

In the locked position of the cap 20 of the device 1 on the container 10, the closing-off element 45 is positioned in the opening in the container 10 so as to be in contact with the seal 14. The upper part 41 of the closing-off element 45 may come into axial abutment against the upper peripheral rim of the neck 12. The elastic ring 36 is in its rest position and the retaining means 38 is projecting from the outside of the hoop 33 so as to be engaged in a catching means 23 of the insert 21, the cap 20 then being held axially by the locking mechanism 30.

In order to unlock the cap, the user exerts a pressure on the means 37 for actuating the retaining means 38 in order to inactivate the retaining means 38 so as to enable the cap 20 to move purely in translation with respect to the container 10. During this movement, the closing-off element 45 can remain in position in the opening in the container and also in the unlocked position in which the radial contact between the seal 14 and the closing-off element 45 is preserved, making it possible to maintain impermeability even in the unlocked position.

The user can then remove the cap 20 by exerting an axial pulling force greater than the frictional force exerted by the closing-off element 45 on the seal 14.

Besides providing constant impermeability in spite of a variation in the relative positioning height of the closing-off member with respect to the seal 14, for example if the cap is not fully screwed onto the container, this sealing arrangement allows, by virtue of the empty volume, greater deformation of the seal 14 and thus allows better compensation of the variations in dimensions of the components. This feature makes it possible to create containers having non-circular shapes, for example having an opening and an oblong seal for an elongate applicator snap-fastened onto the container.

Another advantage of this invention is that a device that does not require a significant closing force in order to obtain sufficient impermeability is obtained.

The invention is not limited to the examples illustrated. The features of the various examples can in particular be combined as parts of variants which are not illustrated.

The expression "comprising a" should be understood as meaning  
5 "comprising at least one", unless specified to the contrary.

**CLAIMS**

1. Device for packaging a cosmetic product, comprising:
  - a container having an opening defined by a neck of the container,
  - 5 – a cap for closing the container,
  - a closing-off element for the opening, connected to the cap,
  - a seal mounted in a fixed manner in the neck of the container and able to engage with the closing-off element to obtain contact to form impermeability between the seal and the closing-off element,
  - 10 the device being characterized in that a portion of the seal is not in contact with the neck so as to form a free volume between the outer wall of the seal and the inner wall of the neck, and in that the contact between the seal and the closing-off element is only radial with respect to the axis of the opening in the container.
  - 15
2. Device according to the preceding claim, characterized in that the inner face of the seal has an annular bulge that engages with the closing-off element, said annular bulge being positioned at the free volume.
- 20 3. Device according to either of the preceding claims, characterized in that the cap is moved from its locked position to its unlocked position by the cap moving purely in translation with respect to the container.
4. Device according to one of the preceding claims, characterized in that the closing-off element comprises an applicator which extends from the cap into the container, and in that the seal comprises a portion for wiping the applicator.
- 25

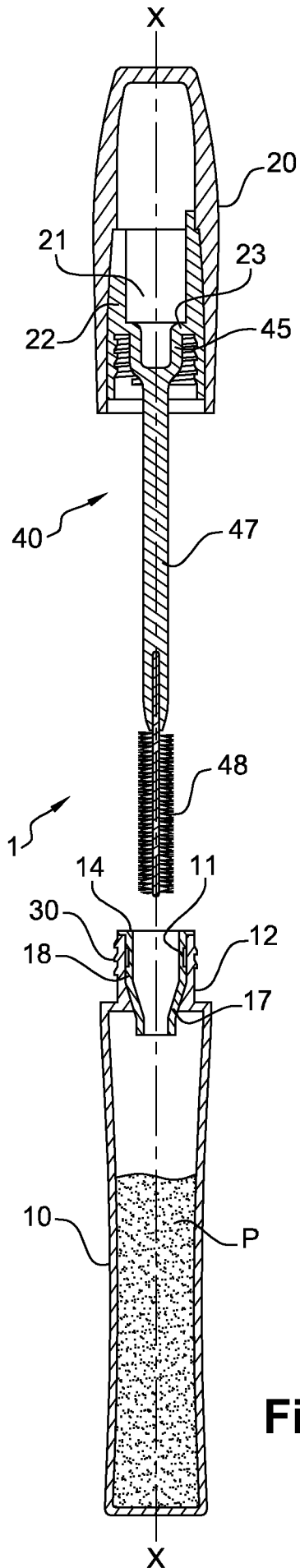

Fig. 1

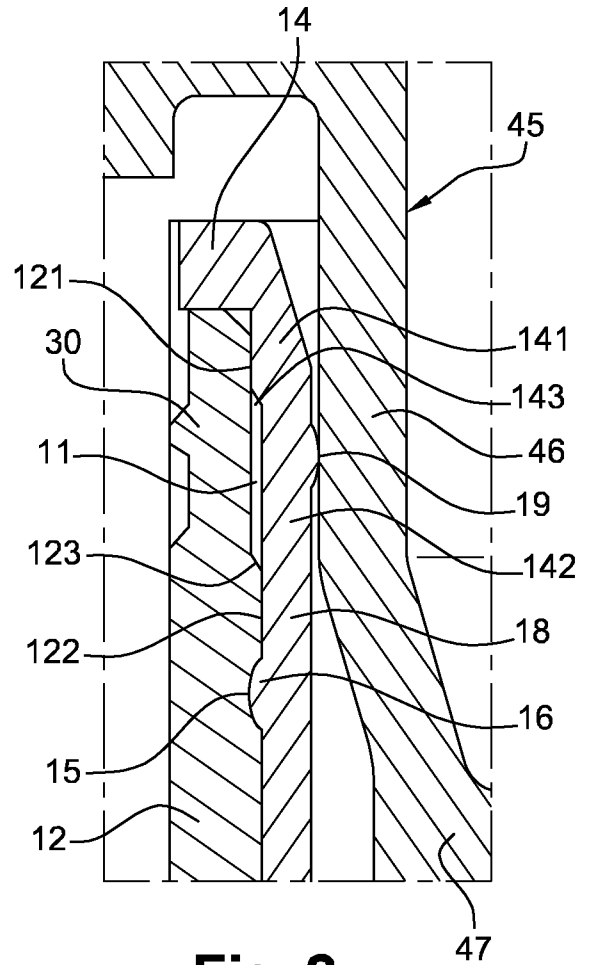
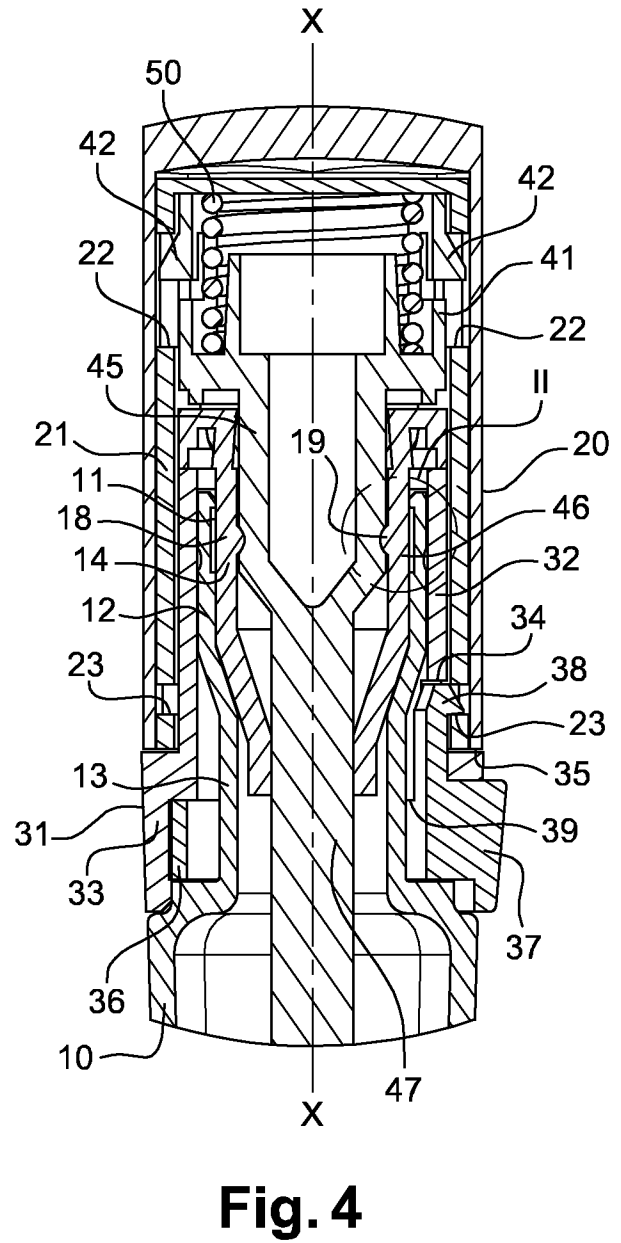
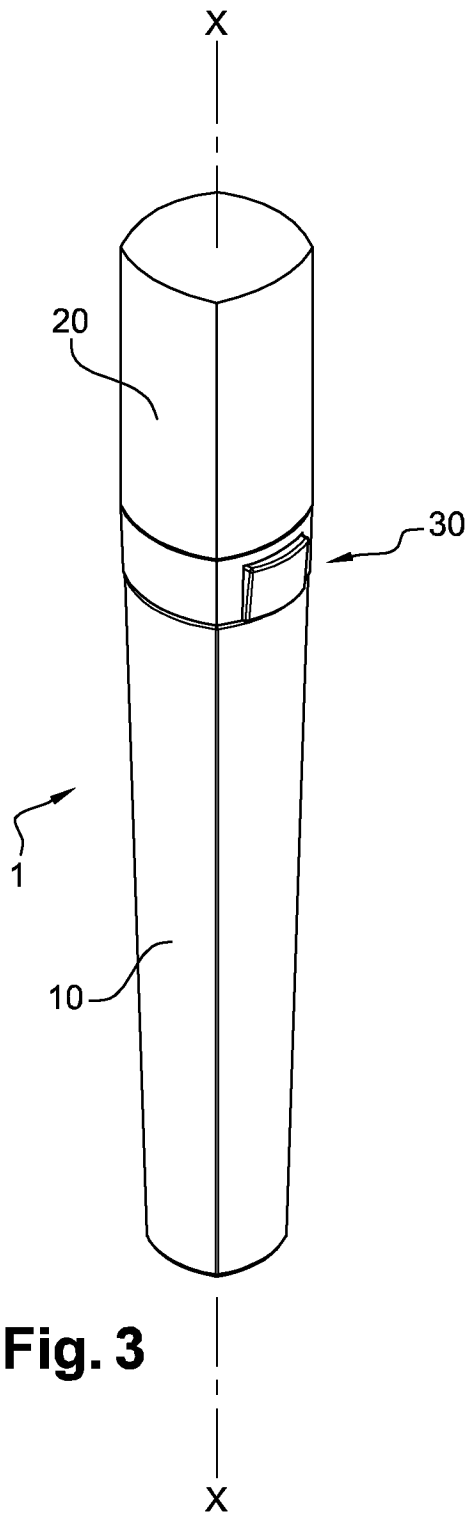

Fig. 2



# INTERNATIONAL SEARCH REPORT

International application No PCT/EP2012/064964
---

<b>A. CLASSIFICATION OF SUBJECT MATTER</b> INV. A45D40/26      B65D41/04      B65D53/02 ADD.				
According to International Patent Classification (IPC) or to both national classification and IPC				
<b>B. FIELDS SEARCHED</b>				
Minimum documentation searched (classification system followed by classification symbols) A45D B65D				
Documentation searched other than minimum documentation to the extent that such documents are included in the fields searched				
Electronic data base consulted during the international search (name of data base and, where practicable, search terms used)  EPO-Internal, WPI Data				
<b>C. DOCUMENTS CONSIDERED TO BE RELEVANT</b>				
Category*	Citation of document, with indication, where appropriate, of the relevant passages	Relevant to claim No.		
X,P	WO 2012/076402 A1 (OREAL [FR]; DRUGEON LIONEL [FR]; DELAGE JEAN-FRANCOIS [FR]; LEBRAND JE) 14 June 2012 (2012-06-14) page 3, line 1 - page 4, line 20; figures 1-12 -----	1-4		
X	WO 2010/125758 A1 (YOSHINO KOGYOSHO CO LTD [JP]; SUZUKI KAZUO [JP]; SAKAMOTO SATOSHI [JP]) 4 November 2010 (2010-11-04) page 3 - page 4; figure 1 -----	1,2,4		
Y		3		
Y	FR 2 936 938 A1 (CHANEL PARFUMS BEAUTE [FR]) 16 April 2010 (2010-04-16) page 13, line 23 - page 13, line 30 -----	3		
-/--				
<input checked="" type="checkbox"/> Further documents are listed in the continuation of Box C. <input checked="" type="checkbox"/> See patent family annex.				
* Special categories of cited documents : <table style="width: 100%; border: none;"> <tr> <td style="width: 50%; border: none; vertical-align: top;">                     "A" document defining the general state of the art which is not considered to be of particular relevance                      "E" earlier application or patent but published on or after the international filing date                      "L" document which may throw doubts on priority claim(s) or which is cited to establish the publication date of another citation or other special reason (as specified)                      "O" document referring to an oral disclosure, use, exhibition or other means                      "P" document published prior to the international filing date but later than the priority date claimed                 </td> <td style="width: 50%; border: none; vertical-align: top;">                     "T" later document published after the international filing date or priority date and not in conflict with the application but cited to understand the principle or theory underlying the invention                      "X" document of particular relevance; the claimed invention cannot be considered novel or cannot be considered to involve an inventive step when the document is taken alone                      "Y" document of particular relevance; the claimed invention cannot be considered to involve an inventive step when the document is combined with one or more other such documents, such combination being obvious to a person skilled in the art                      "&amp;" document member of the same patent family                 </td> </tr> </table>			"A" document defining the general state of the art which is not considered to be of particular relevance "E" earlier application or patent but published on or after the international filing date "L" document which may throw doubts on priority claim(s) or which is cited to establish the publication date of another citation or other special reason (as specified) "O" document referring to an oral disclosure, use, exhibition or other means "P" document published prior to the international filing date but later than the priority date claimed	"T" later document published after the international filing date or priority date and not in conflict with the application but cited to understand the principle or theory underlying the invention "X" document of particular relevance; the claimed invention cannot be considered novel or cannot be considered to involve an inventive step when the document is taken alone "Y" document of particular relevance; the claimed invention cannot be considered to involve an inventive step when the document is combined with one or more other such documents, such combination being obvious to a person skilled in the art "&" document member of the same patent family
"A" document defining the general state of the art which is not considered to be of particular relevance "E" earlier application or patent but published on or after the international filing date "L" document which may throw doubts on priority claim(s) or which is cited to establish the publication date of another citation or other special reason (as specified) "O" document referring to an oral disclosure, use, exhibition or other means "P" document published prior to the international filing date but later than the priority date claimed	"T" later document published after the international filing date or priority date and not in conflict with the application but cited to understand the principle or theory underlying the invention "X" document of particular relevance; the claimed invention cannot be considered novel or cannot be considered to involve an inventive step when the document is taken alone "Y" document of particular relevance; the claimed invention cannot be considered to involve an inventive step when the document is combined with one or more other such documents, such combination being obvious to a person skilled in the art "&" document member of the same patent family			
Date of the actual completion of the international search	Date of mailing of the international search report			
9 October 2012	16/10/2012			
Name and mailing address of the ISA/ European Patent Office, P.B. 5818 Patentlaan 2 NL - 2280 HV Rijswijk Tel. (+31-70) 340-2040, Fax: (+31-70) 340-3016	Authorized officer  Ehram, Sabine			

INTERNATIONAL SEARCH REPORT

International application No  
PCT/EP2012/064964

C(Continuation). DOCUMENTS CONSIDERED TO BE RELEVANT		
Category*	Citation of document, with indication, where appropriate, of the relevant passages	Relevant to claim No.
X	FR 2 515 941 A1 (OREAL [FR]) 13 May 1983 (1983-05-13) page 6, line 15 - page 10, line 4; figures 1-4	1,4
X	----- JP 2008 086547 A (YOSHINO KOGYOSHO CO LTD) 17 April 2008 (2008-04-17) figures 1, 2 -----	1,4

# INTERNATIONAL SEARCH REPORT

Information on patent family members

International application No PCT/EP2012/064964
---

Patent document cited in search report	Publication date	Patent family member(s)	Publication date
WO 2012076402 A1	14-06-2012	FR 2968516 A1 WO 2012076402 A1	15-06-2012 14-06-2012
-----			
WO 2010125758 A1	04-11-2010	CN 102413730 A EP 2425740 A1 JP 2010259545 A KR 20120016618 A US 2012039660 A1 WO 2010125758 A1	11-04-2012 07-03-2012 18-11-2010 24-02-2012 16-02-2012 04-11-2010
-----			
FR 2936938 A1	16-04-2010	CN 102186373 A EP 2362741 A1 FR 2936938 A1 US 2011222954 A1 WO 2010043803 A1	14-09-2011 07-09-2011 16-04-2010 15-09-2011 22-04-2010
-----			
FR 2515941 A1	13-05-1983	DE 3240765 A1 FR 2515941 A1 IT 1156234 B US 4407311 A	19-05-1983 13-05-1983 28-01-1987 04-10-1983
-----			
JP 2008086547 A	17-04-2008	JP 4978904 B2 JP 2008086547 A	18-07-2012 17-04-2008
-----			