



US00D737366S

(12) **United States Design Patent**
Rohner et al.

(10) **Patent No.:** **US D737,366 S**

(45) **Date of Patent:** **** Aug. 25, 2015**

(54) **PERCUSSION MUSICAL INSTRUMENT**

FOREIGN PATENT DOCUMENTS

(71) Applicant: **PANArt Hangbau AG**, Bern (CH)

CH 693319 A5 5/2003
WO DM/071656 10/2009

(72) Inventors: **Felix Rohner**, Bern (CH); **Sabina Scharer**, Bern (CH)

OTHER PUBLICATIONS

(73) Assignee: **PANART HANGBAU AG**, Bern (CH)

Instrumundo Instrumentos Musicales. <http://instrumundo.blogspot.com/2012/08/hang-drum.html>. Aug. 2012. "Hang Drum".*

(**) Term: **14 Years**

(Continued)

(21) Appl. No.: **29/448,470**

Primary Examiner — Rashida Johnson

(22) Filed: **Mar. 12, 2013**

(74) *Attorney, Agent, or Firm* — Pearne & Gordon LLP

(30) **Foreign Application Priority Data**

(57) **CLAIM**

Dec. 3, 2012 (WO) 706555101

We claim the ornamental design for a percussion musical instrument, as shown and described.

(51) **LOC (10) Cl.** **17-04**

DESCRIPTION

(52) **U.S. Cl.**

USPC **D17/22**

(58) **Field of Classification Search**

USPC D17/22, 24, 99; 84/102, 103, 104, 402, 84/403, 404, 406, 409, 410, 411 R, 414, 84/411 M, 411 P, 422.1–422.3, 457, 84/DIG. 12, 645; D21/405

See application file for complete search history.

FIG. 1 is a front view of the percussion musical instrument. FIG. 2 is a right side view of the percussion musical instrument.

FIG. 3 is a left side view of the percussion musical instrument. FIG. 4 is a rear view of the percussion musical instrument.

FIG. 5 is a top view of the percussion musical instrument.

FIG. 6 is a bottom view of the percussion musical instrument.

FIG. 7 is a right front perspective view of the percussion musical instrument; and,

FIG. 8 is a left front perspective view of the percussion musical instrument.

In FIGS. 1-8, the broken lines represent the portions of the percussion musical instrument that form no part of the claimed design.

The dot-dashed lines, in FIGS. 1-4 and 6, represent a boundary line, which forms no part of the claimed design.

(56) **References Cited**

U.S. PATENT DOCUMENTS

D319,249 S * 8/1991 Aluisi D17/22
5,973,247 A * 10/1999 Matthews 84/402
6,212,772 B1 4/2001 Whitmyre et al.
D620,041 S * 7/2010 Doe D17/22
D637,224 S * 5/2011 Smith D17/24
8,492,632 B1 * 7/2013 Doe 84/406
2009/0193958 A1 8/2009 Webb
2012/0304845 A1 12/2012 Rohner et al.

1 Claim, 4 Drawing Sheets

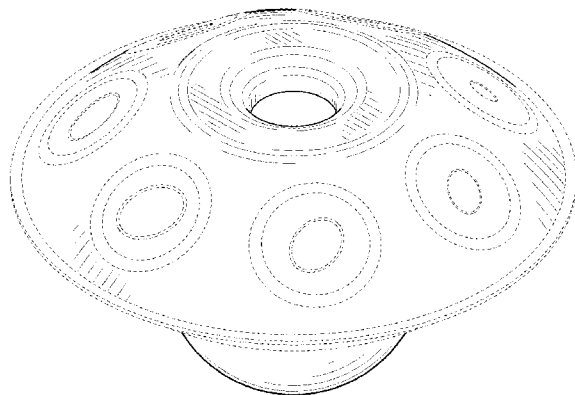
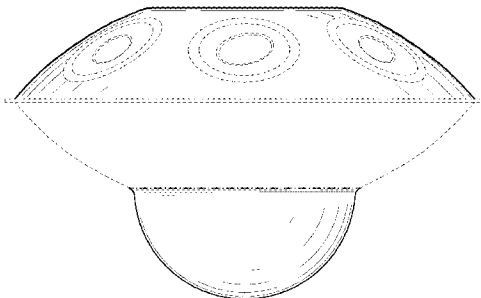

(56)

References Cited

OTHER PUBLICATIONS

World Percussion: David Kuckhermann. <http://worldpercussion.net/instruments/panart-hang-and-handpans/>. Date Viewed: Feb. 2015.

"The PanArt Hang (Drum) and HandPans".*

Bali Steel Pan. <http://www.balisteelpan.com/>. Aug. 2010. "Hand Pans".*

Hansen, U.J. and Rossing, T.D., "The Caribbean Steelpan, and some Offsprings," Forum Acusticum 2005, Budapest, Hungary, 6 pages.

Panart Hangbau AG, "Hang," Jan. 2008, Bern, Switzerland, 24 pages.

Rohner, F. and Scharer, S., "Hang Guide," Spring 2010, Bern, Switzerland, 24 pages.

Rohner, F. and Scharer, S., "History, Development and Tuning of the Hang," International Symposium on Musical Acoustics (ISMA 2007), Sep. 9-12, 2007, Barcelona, Spain, 8 pages.

Rossing, T.D. et al., "Acoustics of the Hang: A hand-played steel instrument," International Symposium on Musical Acoustics (ISMA 2007), Sep. 9-12, 2007, Barcelona, Spain, 8 pages.

Wessel, D. et al., "Sound of the Hang," Proceedings of Meetings on Acoustics, vol. 4, 035002, 2008, 8 pages, Jul. 2008.

Photo of "Genesis" Instrument, published on www.smartypans.com at least as early as Mar. 15, 2012.

* cited by examiner

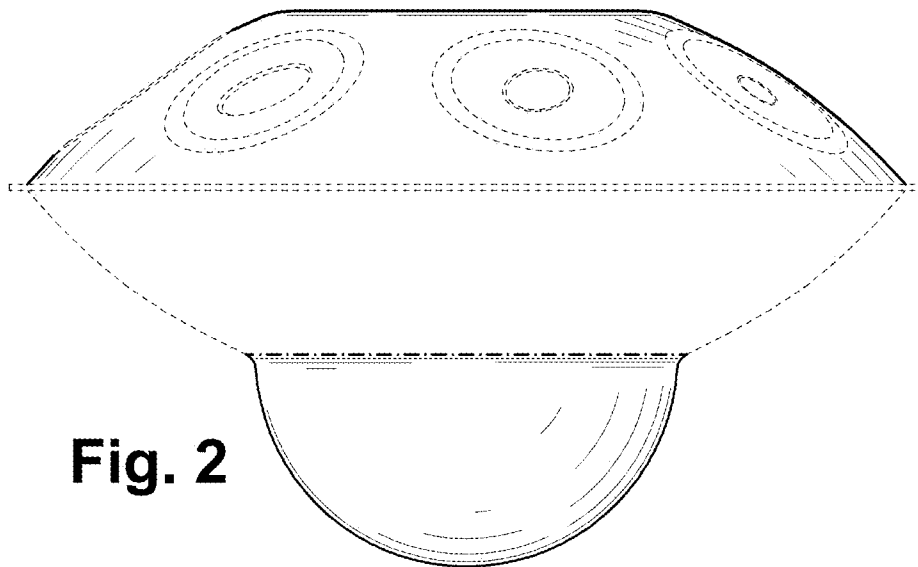
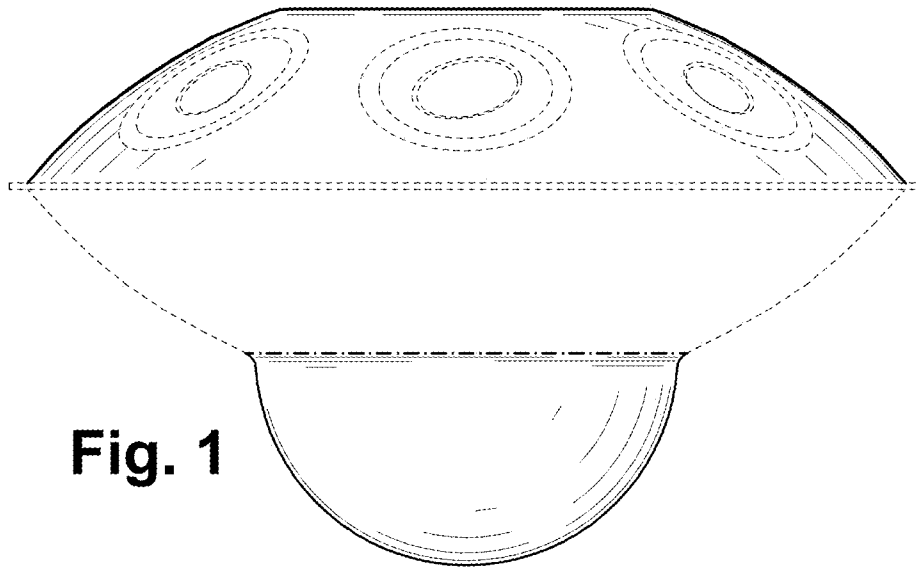

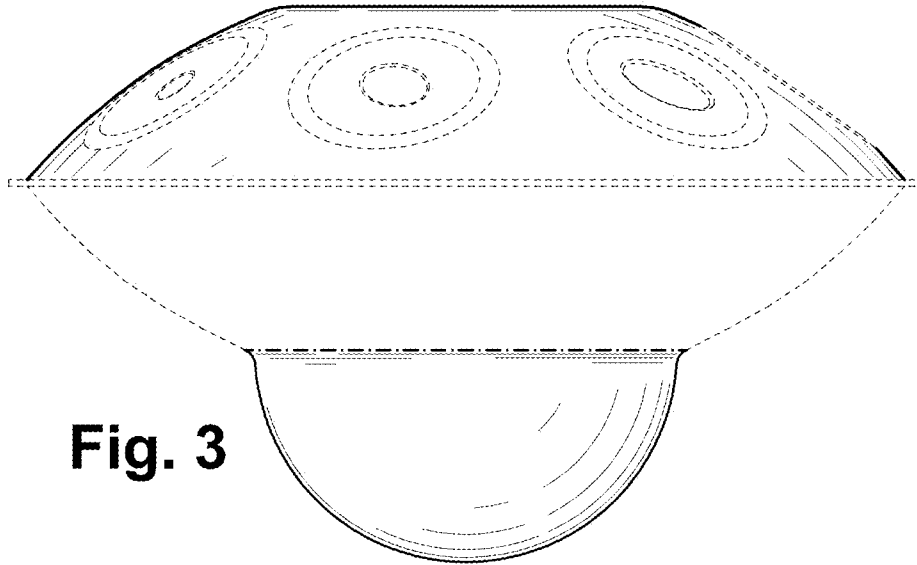

Fig. 3

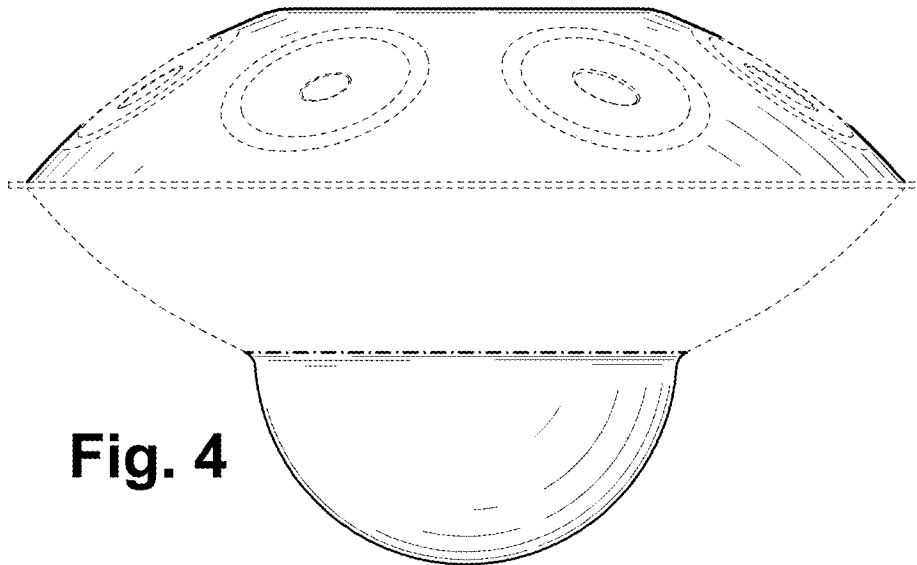

Fig. 4

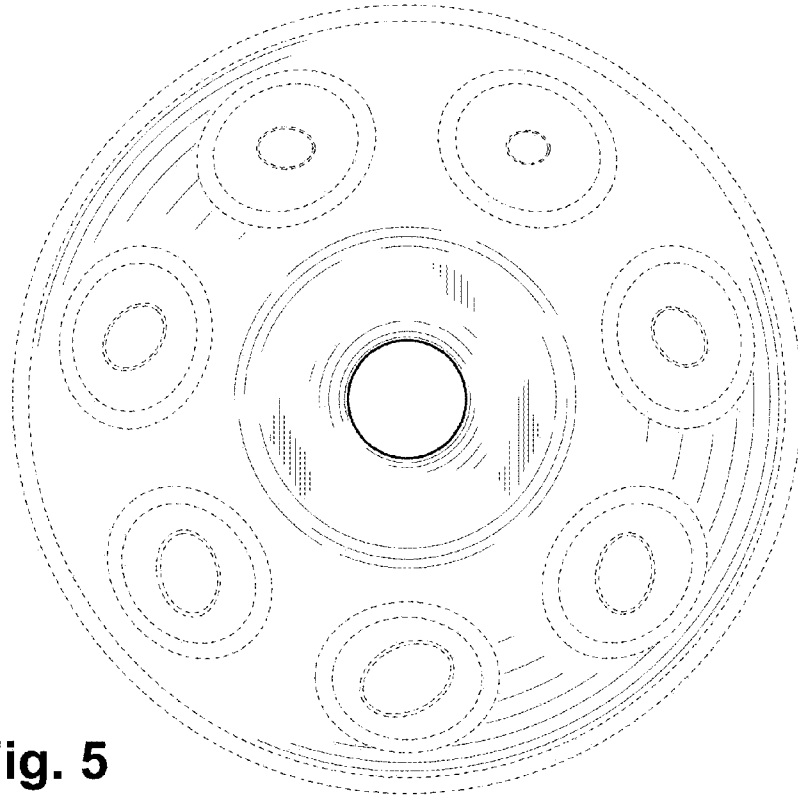

Fig. 5

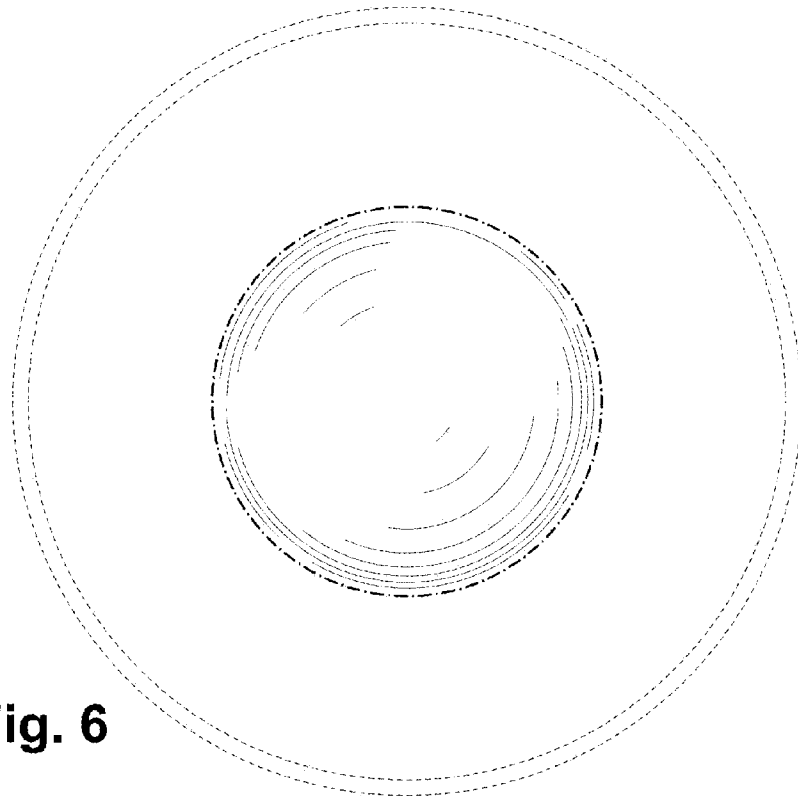

Fig. 6

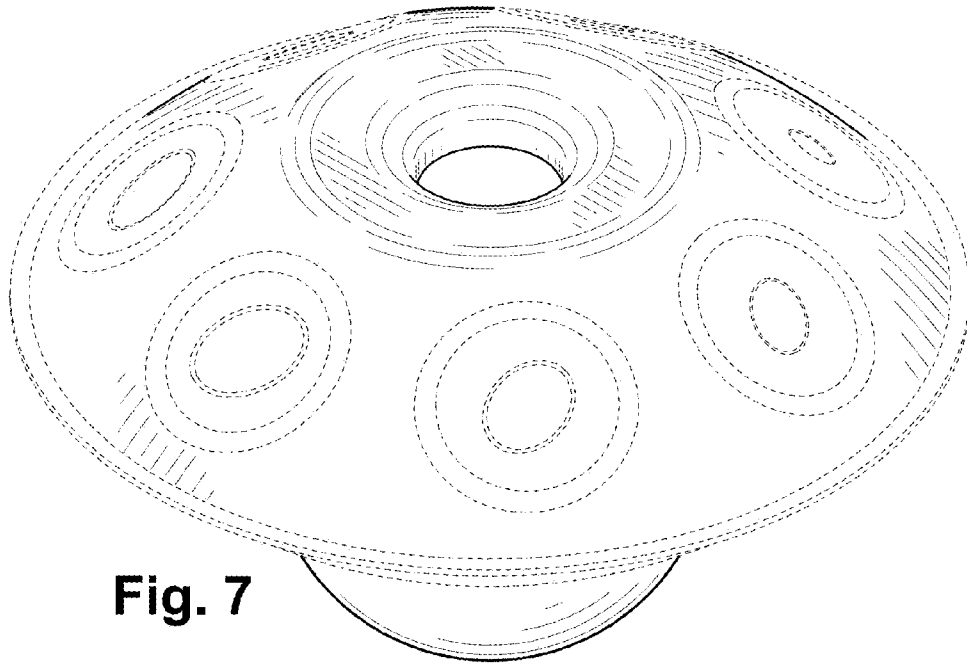

Fig. 7

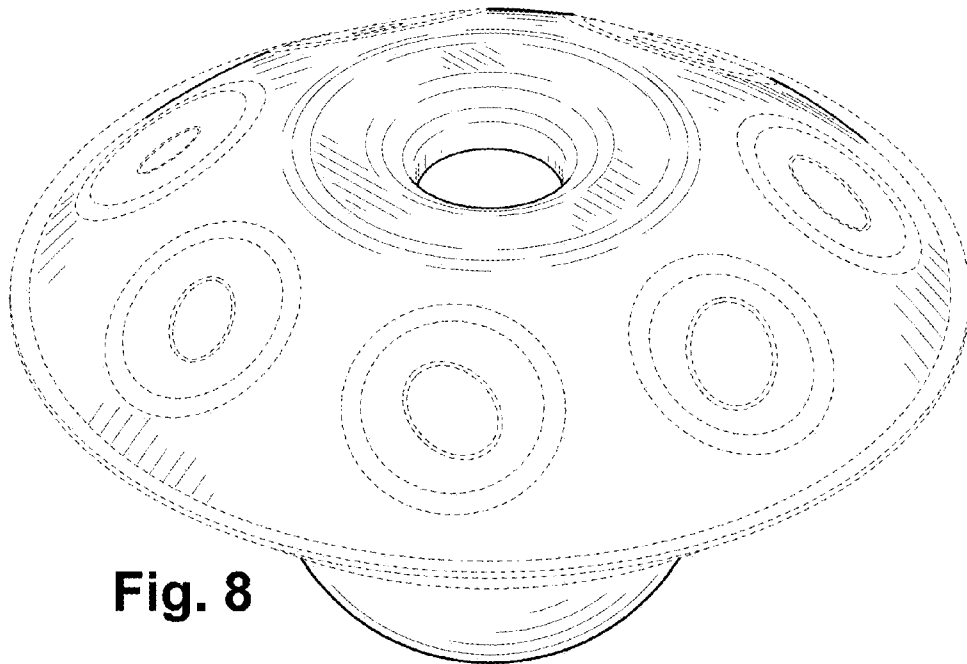

Fig. 8