

Oct. 30, 1934.

S. B. E. TIBERG

1,978,772

COMBINED CLEANING AND CUT-OFF DEVICE IN GASIFICATION BURNERS

Filed Aug. 20, 1932

FIG: 1.

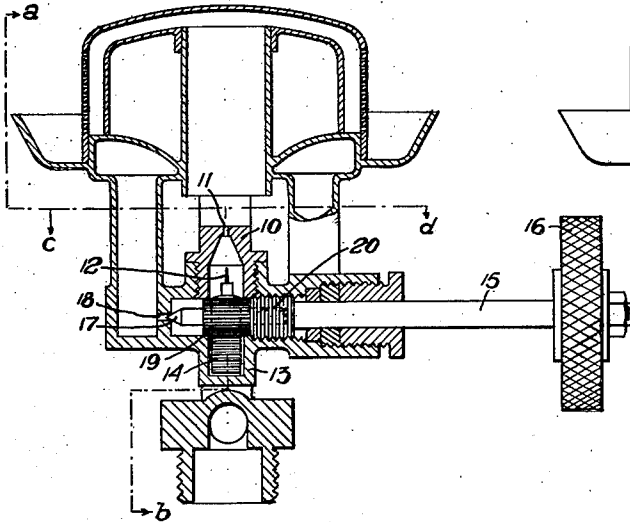

FIG: 2.

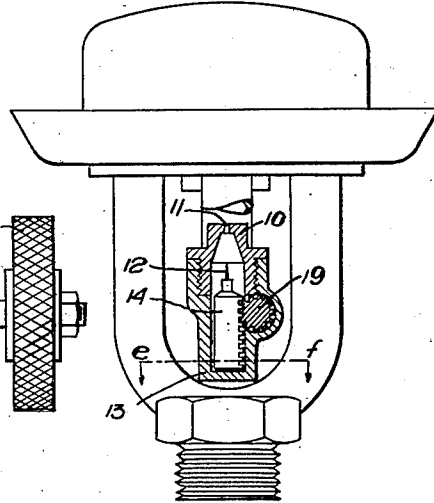

FIG: 3.

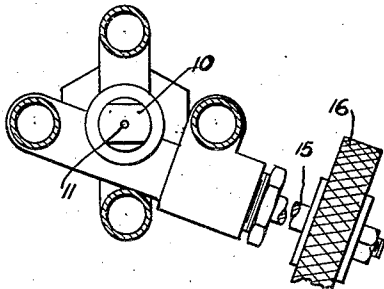
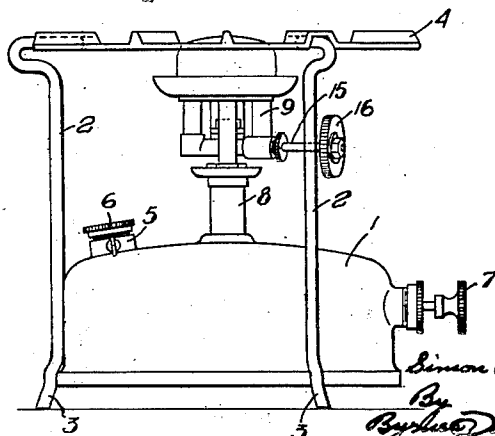

FIG: 4.



FIG: 5.



Inventor:
Simon B. E. Tiberg,
By
Byrd & Demmond + Potter,
Attorneys.

UNITED STATES PATENT OFFICE

1,978,772

COMBINED CLEANING AND CUT-OFF DEVICE IN GASIFICATION BURNERS

Simon Bernhard Emanuel Tiberg, Malarhojden,
Sweden, assignor to Aktiebolaget RADIUS,
Stockholm, Sweden, a joint-stock company of
Sweden

Application August 20, 1932, Serial No. 629,703
In Sweden August 27, 1931

2 Claims. (Cl. 158—120)

The present invention relates to a gasification burner provided with a device for cutting off or for controlling the flow of gas to the burner nozzle, as well as with a device for the cleaning of the nozzle. The object of the invention is to bring about such a combination and cooperation between these devices that they cannot operate at the same time. Thus, if the cut-off and control device is operative, the cleaning needle of the burner nozzle, which entails the advantage that if the flow of gas has been reduced down to a small flame, there need never be the risk of the cleaning needle being introduced into the nozzle opening so as to interfere with the delicate small flame, whereby the same would go yellow and soot. On the other hand, if the cleaning needle has been introduced into the nozzle opening to effect cleaning, the cut-off and control device is made inoperative, so that the gas passage will be entirely open for the flow of gas out to and through the nozzle opening, which entails the advantage that the free, comparatively powerful flow of gas may when forcing its way out through the nozzle opening entrain the impurities that have been loosened by the needle or, in other words, blow the opening clean.

The arrangement according to the invention is principally characterized in that the device for controlling the gas supply and the device for cleaning the burner nozzle are combined with each other in such a manner that, when the cleaning device moves from operative into inoperative position, the gas control device moves continuously from inoperative into operative position.

The invention is applied to the best advantage in the type of burners where the cut-off and the control is effected with the aid of a valve, the spindle of which forms an angle with the longitudinal direction of the nozzle opening. With this arrangement, the valve spindle and the cleaning needle adapted to be introduced into the opening may be mechanically connected in the simplest manner to bring about the alternate function aimed at.

The accompanying drawing illustrates by way of example an embodiment of the invention as applied to a burner of the last-mentioned kind. Fig. 1 shows the burner in elevation and in vertical section. Fig. 2 shows an elevation at right angles to Fig. 1 and cut vertically on line *a—b* in Fig. 1, the section being viewed in the direction of the arrows. Fig. 3 shows a horizontal section of the burner on line *c—d* in Fig. 1. Fig. 4

shows to a larger scale a horizontal section on line *e—f* in Fig. 2, and Fig. 5 shows to a smaller scale an assembly of a petroleum cooker provided with a burner according to the invention.

The arrangement according to the invention is primarily intended for the type of petroleum cookers illustrated in Fig. 5. Such a cooker consists in known manner of a fuel container 1, to which are externally secured posts 2, the lower ends of which form the feet 3 of the cooker, while the upper ends of said posts carry a frame 4 on which the cooking vessel stands during cooking. The liquid fuel, generally petroleum, may be filled into the container 1 through the inlet 5 thereof, which is covered by the screw cap 6. By means of the air pump 7 a pressure above atmospheric is produced within the container 1, so that the liquid fuel therein is forced through the riser pipe 8 up to the gasification burner 9 in order to be gasified by the latter, the gasified fuel being then combusted when flowing out through the nozzle opening of the burner. The arrangement of the burner 9 provided according to the invention will be described in detail in the following.

10 is the burner nozzle with the gas opening 11. 12 is the cleaning needle adapted to be introduced into the opening, said needle being attached to a slide 14 adapted to be displaced up and down within the sleeve 13. 15 is the threaded valve spindle of the cut-off and control device, which spindle is adapted to be screwed in and out in known manner, the turning movement of the spindle being effected by means of an external knob 16 secured to the other end of the spindle. The inner end of the valve spindle is formed into or connected with the needle valve 17 adapted more or less to cut off the gas passage opening 18. In the proximity of the valve 17 the spindle 15 is formed into or connected with a pinion 19 cooperating with the one side of the slide 14 formed into a toothed rack. The gear connection is such that when the valve spindle is turned in a clockwise direction, which corresponds to turning to the left according to Fig. 2, the gas inlet opening 18 will be closed more or less, while the slide 14 with the cleaning needle 12 is at the same time displaced so far down that the needle cannot enter the nozzle opening 11, when the spindle 15 is then turned to and fro within certain limits, for the purpose of controlling the flow of gas. Again, if the spindle 15 is turned in a counter clockwise direction, which corresponds to a turning movement to the right according to Fig. 2, the needle 12 is caused to project up into the nozzle opening 11, the valve 17 being removed so far from the

valve seat of the opening 18 that the valve 17 cannot close the opening 18, when the spindle 15 is then turned to and fro as required to move the needle 12 to and fro in the opening 11, in order to effect cleaning.

From Fig. 4 it will be seen how the slide 14, which has a square cross-section, bears with its corners against and is guided by the inside of the sleeve 13, while the segment-shaped spaces about the slide 14 admit a free passage of gas.

To simplify the construction, the pinion 19 and the valve 17 integral therewith are made from a piece of profile metal having the profile of the pinion. The one end of the profile piece is turned down so as to form the valve 17, and the other end so as to form a pin 20 entering a corresponding bore in the spindle 15.

What I claim is:—

1. In combination, a burner body including a casing having an outlet nozzle, said casing having an inlet opening communicating with a source of gaseous fuel under pressure, a fuel control valve comprising a rotatable body having a valve element at one end adapted upon rotation of said valve in alternate directions to open and close said inlet opening to regulate the amount of gaseous fuel delivered to said nozzle, a normally retracted reciprocable cleaning member adapted to enter said nozzle opening to clean the same when moved to projected position, and a rack and pinion connection between said valve body

and said cleaning member for effecting an idle reciprocation of said cleaning member in its retracted position throughout the range of adjustment of said valve body corresponding to flow-controlling adjustments of said valve member with respect to said inlet opening and for moving said cleaning member into projected position to clean said nozzle opening only upon continued rotation of said valve body to move said valve member beyond normally open position.

2. In a gasification burner, a burner body having a fuel inlet and a nozzle constituting the outlet for gaseous fuel, a valve spindle having a valve at one end for cooperation with said inlet to control the flow of fuel to said nozzle and having a threaded section seated in a correspondingly threaded section of the burner body to effect longitudinal adjustment of said spindle and valve when the spindle is rotated, the threaded section of said spindle having a length which permits a further longitudinal displacement of said valve when the latter has reached a position corresponding to a free flow of fuel through said fuel inlet, and means operative to clean said nozzle only when said valve is adjusted within the range of said further longitudinal displacement which does not affect the free flow of fuel through said inlet, said means comprising a nozzle-cleaning member having a rack, and a pinion on said valve spindle and in mesh with said rack.

SIMON BERNHARD EMANUEL TIBERG.

35

110

40

115

45

120

50

125

55

130

60

135

65

140

70

145

75

150