

(19) World Intellectual Property
Organization
International Bureau



(43) International Publication Date
6 May 2005 (06.05.2005)

PCT

(10) International Publication Number
WO 2005/039379 A2

- (51) International Patent Classification⁷: **A61B**
- (21) International Application Number:
PCT/IL2004/000965
- (22) International Filing Date: 24 October 2004 (24.10.2004)
- (25) Filing Language: English
- (26) Publication Language: English
- (30) Priority Data:
60/513,696 24 October 2003 (24.10.2003) US
- (71) Applicant (for all designated States except US):
TONOGURARD LTD. [IL/IL]; Yozmot - Granot,
38100 M.P. Hefer (IL).
- (72) Inventors; and
- (75) Inventors/Applicants (for US only): **GUR, Joshua**
[IL/IL]; Mishmar HaGvul, 97752 Jerusalem (IL).
HAIM-CHOUMLA, Ezra [IL/IL]; P.O.Box 9006,
60920 Kadima (IL). **BARASH, David** [IL/IL]; 4 Beeri
Street, 64682 Tel Aviv (IL).
- (74) Agent: **TSIVION, Yoram**; P.O.B 1307, 37111 Pardes
Hanna (IL).

- (81) Designated States (unless otherwise indicated, for every kind of national protection available): AE, AG, AL, AM, AT, AU, AZ, BA, BB, BG, BR, BW, BY, BZ, CA, CH, CN, CO, CR, CU, CZ, DE, DK, DM, DZ, EC, EE, EG, ES, FI, GB, GD, GE, GH, GM, HR, HU, ID, IL, IN, IS, JP, KE, KG, KP, KR, KZ, LC, LK, LR, LS, LT, LU, LV, MA, MD, MG, MK, MN, MW, MX, MZ, NA, NI, NO, NZ, OM, PG, PH, PL, PT, RO, RU, SC, SD, SE, SG, SK, SL, SY, TJ, TM, TN, TR, TT, TZ, UA, UG, US, UZ, VC, VN, YU, ZA, ZM, ZW.
- (84) Designated States (unless otherwise indicated, for every kind of regional protection available): ARIPO (BW, GH, GM, KE, LS, MW, MZ, NA, SD, SL, SZ, TZ, UG, ZM, ZW), Eurasian (AM, AZ, BY, KG, KZ, MD, RU, TJ, TM), European (AT, BE, BG, CH, CY, CZ, DE, DK, EE, ES, FI, FR, GB, GR, HU, IE, IT, LU, MC, NL, PL, PT, RO, SE, SI, SK, TR), OAPI (BF, BJ, CF, CG, CI, CM, GA, GN, GQ, GW, ML, MR, NE, SN, TD, TG).

Published:
— without international search report and to be republished upon receipt of that report

For two-letter codes and other abbreviations, refer to the "Guidance Notes on Codes and Abbreviations" appearing at the beginning of each regular issue of the PCT Gazette.

(54) Title: DEVICE FOR MEASUREMENT OF INTRA OCCULAR PRESSURE

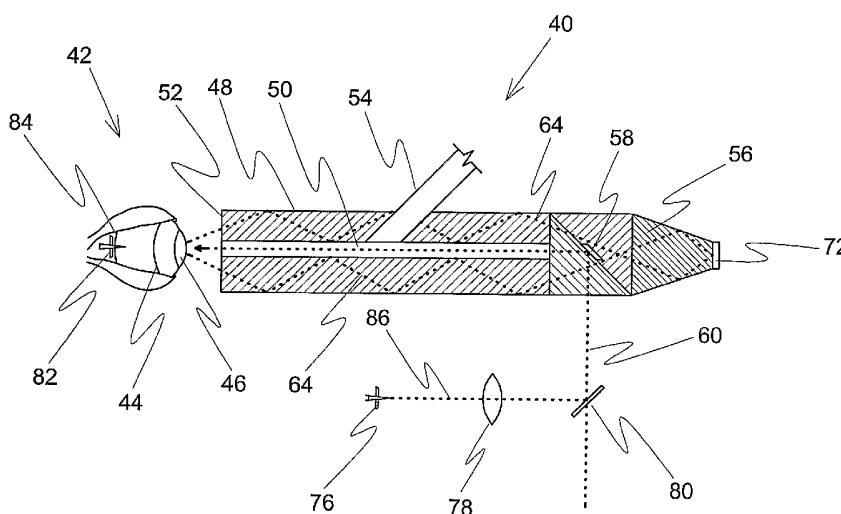

(57) Abstract: A non-contact tonometer for measuring the intra-ocular pressure of an eye, projecting light into the eye and measuring the reflected light as affected by mechanical distortion. The cornea is distorted by delivering a pneumatic pulse. The tonometer consists mainly of an electro-optical unit mountable on the head of a user and a control unit. The control unit of the tonometer includes a display and optionally an audio device for instructing the user. The electro-optical unit employs a tubular wave guide, a light detector, and a reflector for deflecting a light beam to the eye and for eliminating a part of the reflected light reaching the detector. The aligning of the tonometer with the head of the user is optionally assisted by a reticle observed.

WO 2005/039379 A2

DEVICE FOR MEASUREMENT OF INTRA OCCULAR PRESSURE

TECHNICAL FIELD OF THE INVENTION

5 The present invention relates generally to tonometry and more particularly to non-contact tonometry. The invention also relates to measurement of intra ocular pressure (IOP) and to devices for measuring same.

BACKGROUND OF THE INVENTION

10 The significance of measurement of the hydrostatic intra-ocular pressure (IOP) is well known in medicine (ophthalmology). Excessive Internal eye pressure is a cause of glaucoma and other eye diseases.

 Professional medical staff, using a variety of methods – mainly the indentation tonometry, the applanation tonometry and the non-contact tonometry, performs common measurements of IOP. Available in the market are several systems. An indentation tonometry system is the Schiotz tonometer, which dates back to the nineteenth thirties. A more recent system is the Mentor Tono-Pen XL from Mentor O&O, Inc. of Norwell, Ma US. An applanation tonometry system is the Goldman
15 tonometer, which is a standard tonometer in a considerable amount of medical
20 institutions. Above mentioned systems and methods are based on direct contact with

the corneal eye associated with liquids and medications applied to the eye. A non-contact tonometry is preferable since it decreases hazards to the tested eye associated with the measurement process. A non-contact tonometry system is the puff tonometer XPERT NCT from Reichert Cambridge US. Puff tonometry employs detecting changes
5 in the reflectance of a cornea, which is distorted by a pneumatic pulse. The measurement process basically includes the steps of: (i) placing and aligning the tonometer in front of the tested eye; (ii) measuring the intensity of a light reflected by a test area within the surface of the cornea; (iii) distorting the cornea by projecting a pneumatic pulse towards it, and (iv) matching features of the intensity-time profile of
10 the light reflected by the distorted cornea with IOP values. The accuracy of IOP values obtained is considerably affected by misplacement or misalignment of the tonometer. Therefore allowed tolerances of placement and alignment are significantly narrow.

Once a patient is diagnosed as having an excessive eye pressure, he/she is to have IOP monitored periodically – typically at different hours during the day. It is
15 desirable that a user is be able to measure his or her own IOP at home, rather than make special visit to the clinic for this purpose. However current commercially available devices providing for self – examination of IOP are not satisfactory mainly due to accuracies and cost considerations.

Therefore efforts to develop a self -operated tonometer suitable for home
20 medicine are on going. US patent 6,440,070 discloses a device consisting of a gauge, which is pushed against the eyelid while force is measured. An ultrasound-measuring device is also used to measure a distance from an internal object within the tested eye. Correlating the force applied to the displacement of the pressed surface caused by this applied force provides assessment of pressure. US patent 6,746,400 discloses a
25 system implementing of a plurality of pressure sensors providing also a spatial

- distribution of pressure from which IOP can be derived. Both above mentioned inventions involve direct or indirect contact with the tested eye. Measured IOP values obtained thus are considerably less sensitive to fitting or aligning of the measuring gear as compared to those obtained by current systems employing optical measurements.
- 5 However patients tend to decline using a measuring system which entails applying force by touching the eye.

BRIEF DESCRIPTION OF THE DRAWINGS

Fig. 1 is schematic side view of a non-contact tonometer as applied to patient according to a preferred embodiment of the present invention;

5 Fig. 2 is a schematic longitudinal sectional view of a segment of the optical unit of the non-contact tonometer of the invention;

Fig 3 is a graph describing simulated pressure of compressed air and intensity of reflected light versus time for the tonometer;

10 Fig. 4 is a schematic block diagram of the control unit showing main components.

DETAILED DESCRIPTION OF THE PRESENT INVENTION

The present invention provides a method for determining internal pressure within deformable bodies by measuring the dynamics of reflectance changes from the body in response to mechanical disturbance applied to the body. The method provides considerably wider tolerances in placement and alignment of the tonometer related to the test area without sacrificing essential measurement accuracies. The method is suitable for measuring internal pressure within most kinds of deformable bodies having a convex surface and in particular for measuring intra ocular pressure (IOP).

Reference is made to **Fig. 1** showing a tonometer adapted for measurement of IOP, according to a preferred embodiment of the present invention. Electro-optical unit **2** having a cylindrical extension **4** is placed in front of a patient. The electro-optical unit is attached by means of a connecting device **6** to a mounting device consisting of frame **8**, which is placed over the patient's head. Stripes **10** supporting frame **8** over the head, and the aperture which faces the eye **12** (not shown) is fixed in place by means of adjustable stripes **14** by urging the frame against the patient's forehead. The mounting device of this tonometer consists of frame **8**, stripes **10**, stripes **14** and a connecting device **6**. The connecting device **6** is slidably attached to frame **8** in front of either left or right eye by means of clamping device or a screw (not shown). A flexible tube **20** conveying compressed air and a power and signal cable **22** connects electro-optical unit **2** with the control unit **30** of the tonometer. A display **32** on which operating instructions and measurements results are shown, is located at the front panel of the control unit **30**. Functional keys **34** and a main operating switch **36** are also installed on this front panel. The user (patient) initiates the operation by attaching the electro-optical unit **2** to frame **8** in its pre-assigned place for attending to the left or right eye. Then

after turning operating switch **36** on, the user mounts frame **8** over his head and adjust its placement by means of the adjustable stripes **14** to fit in front of his selected eye. By turning the system on, an illuminating beam is emitted from an optical aperture located on the side of the electro-optic unit facing the user. By pressing a functional key the user hears a sound changing its pitch and/or watches the display, on which intensity of reflected light from the surface of his eye is shown, to maximize the intensity and improve placement and pointing of the electro-optical unit in front of his eye. The patient can also activate a reticle by pressing another functional key and center it in his field of view, by which the test area is centered over the corneal apex. The frame, which is adjusted to the user forehead by means of adjustable supporting stripes for securing the position and keeping the user – device combination stable.

Different mounting configurations are possible, as long as the electro-optical unit remains stably mounted on the patient. Another preferred embodiment of a self-operated tonometer according to the present invention takes the form of goggles attached to the user's head by means of flexible strap. In such a case, the electro-optical unit is attached to the goggles corresponding to the selected eye by means of clamping connectors.

Reference is now made to **Fig. 2**, showing a schematic longitudinal sectional view of a segment of the electro-optical unit of a tonometer of the invention. A segment of the electro-optical unit **40** is placed in front of a user's eye **42**. IOP is typically measured in the area of the cornea, preferable at its center, (which is the location of the pupil). Therefore the electro-optical unit is pointing towards the cornea **44** on which substantially central sector **46** are to be illuminated. In a preferred embodiment of the invention, a unitary device which is both a light projecting and a collecting tube (LPCT). The LPCT **48** is positioned in front of the pupil taking care not to touch the eyelashes.

LPCT **48** has a substantially thick wall forming a narrow lumen **50**. Proximal face **52** of LPCT **48** is coated with a suitable anti-reflecting coating. The lumen of flexible tube **54** forms a continuum with the lumen **50** by way of an aperture in the wall of LPCT **48**. The flexible tube is connected, at its distal end, to the source of compressed air (not shown). A light-guiding device **56** is attached to the distal face of LPCT **48** by means of a reflection index - matching glue or any suitable glue such as EPOTEC (a commonly used optical glue). The light guide is cylindrical at its proximal face, matching the external perimeter of LPCT **48**. The light guide assumes the shape of a square prism towards its distal end. A light reflector **58** consisting of a highly reflective, diagonally mounted plate, is attached to the inner surface of the light-guiding device **56** covering the lumen **50** completely. This reflector deflects an illuminating beam **60** directing it along the axis of LPCT **48** to the sector **46**. Different variants of the reflector and its mount are applicable, provided that they cause a substantially total reflection of the light beam towards the eye. The light source emitting collimated light is typically a light emitting diode (LED), not shown,

The wall of LPCT **48** is transparent in the spectral range of the light beam and has a suitable index of refraction. Reflected light beams **64**, reflected from the sector **46** on the eye, are guided by total internal reflection along the walls of LPCT **48** and further propagate through the light guiding device **56** impinging on a light detector **72**. Reflector **58** blocks light reflected from the eye from reaching light detector **72** directly through the lumen **50**. Light detector **72** is attached to the distal face of light guide **56** normal to the axis of LPCT **48**.

The list of reflected light receiving surfaces includes the coated proximal face **52** of the wall of LPCT **48**, reflector **58**, and light detector **72**. The positioning of light

reflector **58** considerably reduces the contribution of light reflected by the corneal apex to the total intensity received by the light detector **72**. Therefore the electro-optical system of the invention is less sensitive to the alignment with the face of the user. The fact that the illuminating beam, the pneumatic pulse and the detector share the same
5 axis makes the system less vulnerable to axis misalignments.

Mounting the device on the user's head is followed by aligning the device on the user's face regulated by maximizing the intensity of reflected light received by the detector. Such a procedure is more suitable for a skilled and trained operator. In order to make the tonometer of the present invention suitable for self – examination of IOP, a
10 reticule is used to simplify the alignment and attaching steps. The patient observes reticule **76** through lens **78** and a beam splitting device **80**. When the user has reticule image **82** centered in the field of view on his/her retina **84** an actuation button is pressed triggering the measurement process. The intensity of light reflected from the cornea is measured by the detector **72**, connected to the electronic subsystem (not
15 shown). The controller unit of the system subsequently sends an instruction to an air switch (both are not shown in this drawing) to release a pulse of compressed air through the flexible tube **54** and subsequently to the tube **50**. The pulse of compressed air, which is directed at sector **46** transiently deforms the cornea distorting its curvature, making it temporarily flatter or even concave. The light beam illuminates the eye where
20 the cornea has been distorted and the changes in geometry yield correlated changes in the amount of reflected light that is captured by face **52** of LPCT **48**. This reflected light is then detected by light detector **72**, which translates the changes in light intensity into changes in an electric signal. This electric signal is further sampled and digitized yielding a series of digital values further sent to the central controller unit for analysis.

Reference is now made to **Fig. 3** showing a graph of simulated pressure readings and intensity of reflected light versus time as generated by the non-contact tonometer of the invention. Pressure values of graph **90** represent measurements made inside the flexible tube near the aperture. The intensity of reflected light at the light detector face is represented by plot **100**. The intensity of received reflected light is maximal as shown by segment **102**, which corresponds to reflection from the undistorted cornea. The larger volume of the lumen of tube **50** and the diversion of the compressed air as it passes the aperture cause pressure values rise at the cornea surface to lag behind in time with respect to the pressure rise at the measuring point. Therefore the cornea maintains its undistorted curvature as the pressure values rise at the measuring point. Flattening of the cornea starts a while after the pneumatic pulse is initiated and similarly the eye resumes its original curvature somewhat before the pressure change is nullified. The cornea is flattened at point **104** in which the intensity is zeroed. The cornea is illuminated with a narrow beam emitted from tube **50**. A convex surface of the undistorted cornea implies a larger effective area, which reflects light back towards face **52**. A planar surface has smaller effective area which reflects this illuminating light towards face **52** of LPCT **48**, and therefore correlates with a lower light intensity reflected. When a certain threshold low reflection intensity is reached, a zero reflectance value is assigned and any lower light intensity reflected is interpreted as zero, even as the cornea assumes a concave structure.

Features of the intensity-time profile **100** are correlated with actual IOP values. IOP values are correlated with the time intervals in which light intensity changes from its maximal value to zero and back again to its maximal value. Higher IOP values correspond to shorter time intervals, at a given pressure-time profile and longer time

intervals correspond to lower IOP values. Therefore measuring this time interval and comparing it with equivalent time intervals measured related to eyes with given IOP, results in an IOP value. Time interval, which is less accurate, may equal the time length of the pneumatic pulse. Alternatively, an IOP value is calculated by comparing the slope of the change in light intensity with equivalent slopes measured related to eyes having given internal pressure. The IOP value of the measured body is determined by associating such time-related features of the measured curve with a given IOP value. These time-related features associated with IOP values are pre-stored in the central controller. Therefore IOP is determined by matching time-related features of measured changes in light intensity with pre-stored IOP values.

An IOP value is displayed followed by a message indicating the user that the measurement process has proceeded properly. Fault indications are displayed when signal intensity, or pressure values exceeds its typical ranges. The user is instructed to activate a built in self - examination procedure and repeat the measurement process if it indicates that the tonometer functions properly. Repeated process starts by checking mounting of the tonometer in front of his eye and centering the reticule image in his field of view.

Reference is now made to **Fig. 4** showing a block diagram of the electronics sub system of a preferred embodiment of the present invention. The display **120** displays instructions to the user as well as results of the measurements. A suitable display device is employed for example a LED/LCD display. The buzzer **122** is a device that makes an audible sound when the attention of the user has to be called to the display. This happens if the measurement fails, or if the battery is low, etc. It also changes its pitch following the intensity of the received signal during the placement and pointing phase. The compressed air valve **124** operates on a command from the

central controller **125**, to project a pneumatic pulse into the system. The driver of illuminating light source **126** and reticule **128** are controlled by the central controller. A trigger button **130**, which is also connected to the central controller initiates the measurement process when pressed by the user after placing and aligning the optical unit with the eye to be tested. A safety air pressure gauge **132** is used in the air release system, to stop the airflow if it exceeds the specified limits of flow or duration. A Light detector circuitry of a reference detector **134** and of the signal detector **136**, include synchronized sampling and digitizing means implemented by suitable sample and hold devices and analog to digital converters, and are connected to the central controller feeding it with data. The reference detector circuit **134** processes the information from a reference detector. The signal detector circuit **136** picks up the information from the light detector **72**, triggered by the reference signal created at the reference detector circuit. This optional reference trigger arrangement enables this circuit to detect very weak signals and thus be very sensitive.

The tonometer according to this preferred embodiment is particularly suitable for self - examination carried out at the convenience of the patient's home. In a preferred embodiment of the present invention a tonometer having an electro-optic unit and a control unit, is mounted on a frame that can be placed on a table. This frame has a curved support on which the patient leans his forehead for aligning the electro - optical unit with the eye. In such an embodiment, alignment of the gear with the eye is confirmed by the medical staff, by watching the intensity level of detected reflected light.

Another variant consist of a plurality of electro-optical units, all linked to one central control unit consisting of PC. The electro-optical units are mounted on a frame that allows several different patients to be examined and their IOP determined.

CLAIMS

1. A method for measuring internal pressure of a body comprising:
 - aligning a longitudinal axis of a light projecting and collecting device with said body;
 - 5 • detecting changes of intensity of light reflected from a convex sector of a surface of said body and delivered by total internal reflection in a light guide, and wherein said changes are related to a distortion induced by a pneumatic pulse, and
 - matching a time-related feature associated with said changes
10 of said light intensity measured with a given pressure value, wherein said time related-feature is any of the following: a time length of said pneumatic pulse, a time interval in which said changes of said light intensity measured are detected, a slope of said changes of said light intensity measured.
- 15 2. A method for measuring internal pressure of a body as in claim 1, wherein said time-related feature is a slope of said changes of said light intensity measured.
3. A method for measuring internal pressure of a body as in claim 1, wherein said
20 body is an eye.
4. A method for measuring internal pressure of a body as in claim 1 and wherein said light projecting and collecting device is a unitary light projecting and collecting device tube (LPCT).

5. A method for measuring internal pressure of a body as in claim 1, wherein said aligning is carried out using a user observed reticle.
- 5 6. A device for measuring internal pressure of a deformable body wherein changes in the reflectance of a sector of said body are measured in correlation with a distortion of said body effected by a pneumatic pulse, and wherein said sector located within a convex surface of said body, said device comprising:
- a first tube having a substantially thick wall pointing at said sector wherein the
10 proximal face of said wall is adapted to receive light reflected from said body;
 - a second tube for conveying pneumatic pulse to said deformable body;
 - a light detector receiving light from said wall of said first tube, and
 - a reflector used for both deflecting a beam of light of a light source through
the lumen of said first tube to said body and for blocking reflected light from
15 said body.
7. A device for measuring internal pressure of a deformable body as in claim 5 and wherein said deformable body is an eye.
- 20 8. A device for measuring internal pressure of a deformable body as in claim 6 comprising in addition a reticle for projecting an image thereof on said eye.
9. A device for measuring internal pressure of a deformable body as in claim 6 and wherein said light detector is connected to a control unit which also compares the

curve of changing reflection of light as correlated with a transient deformation of the eye with stored equivalent slopes of eyes having given internal pressure values.

10. A device for measuring internal pressure of a deformable body as in claim 6 and
5 wherein a mounting is included for securing said the device to the head of the user.

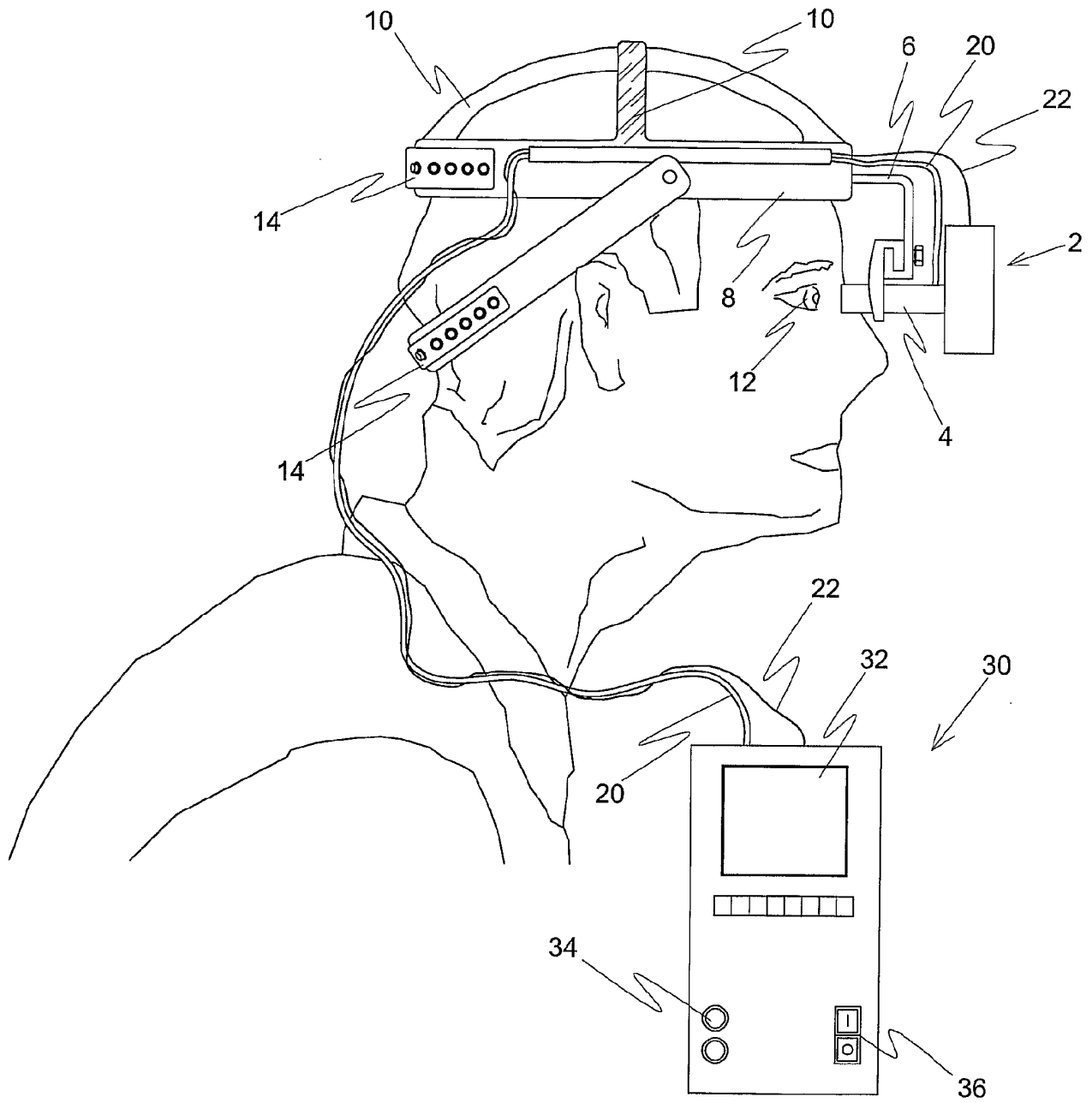

Fig. 1

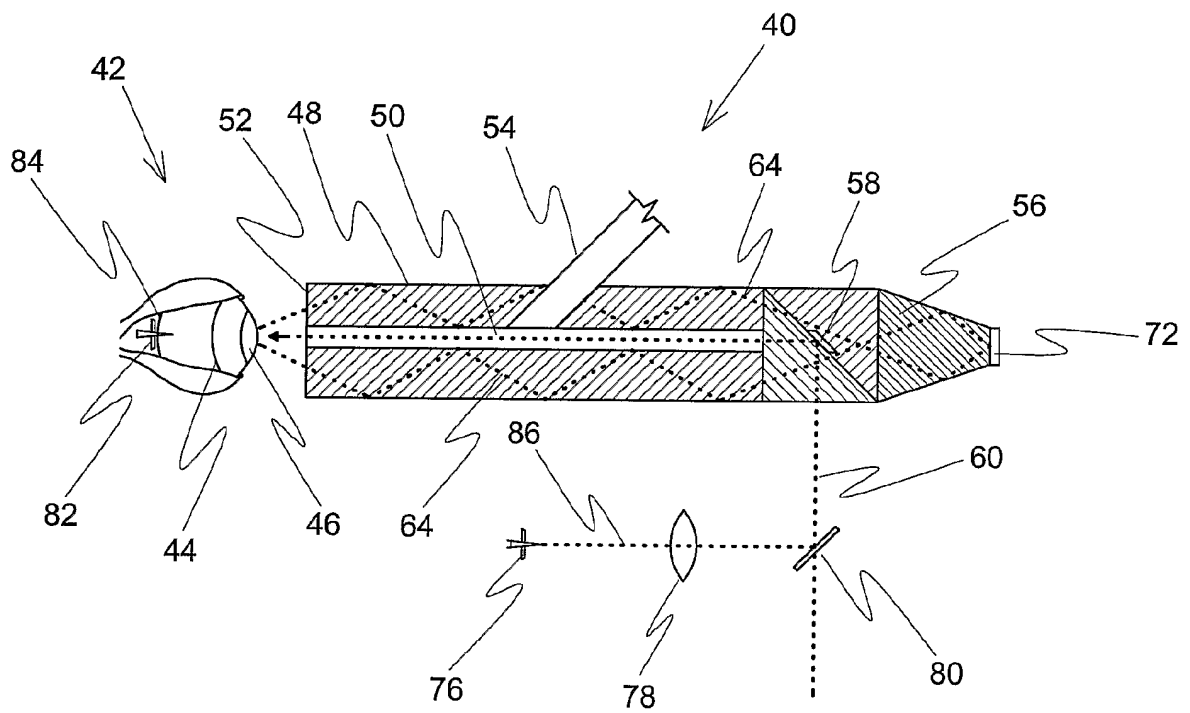

Fig. 2

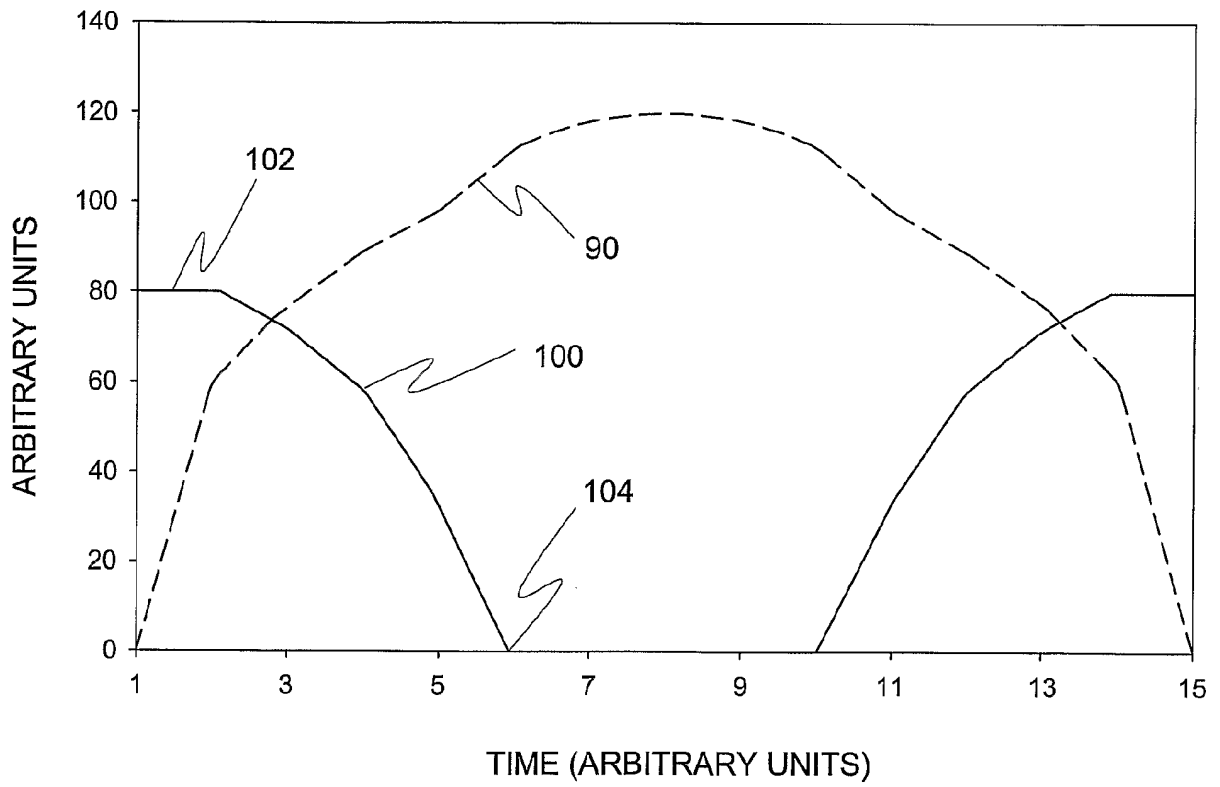

Fig. 3

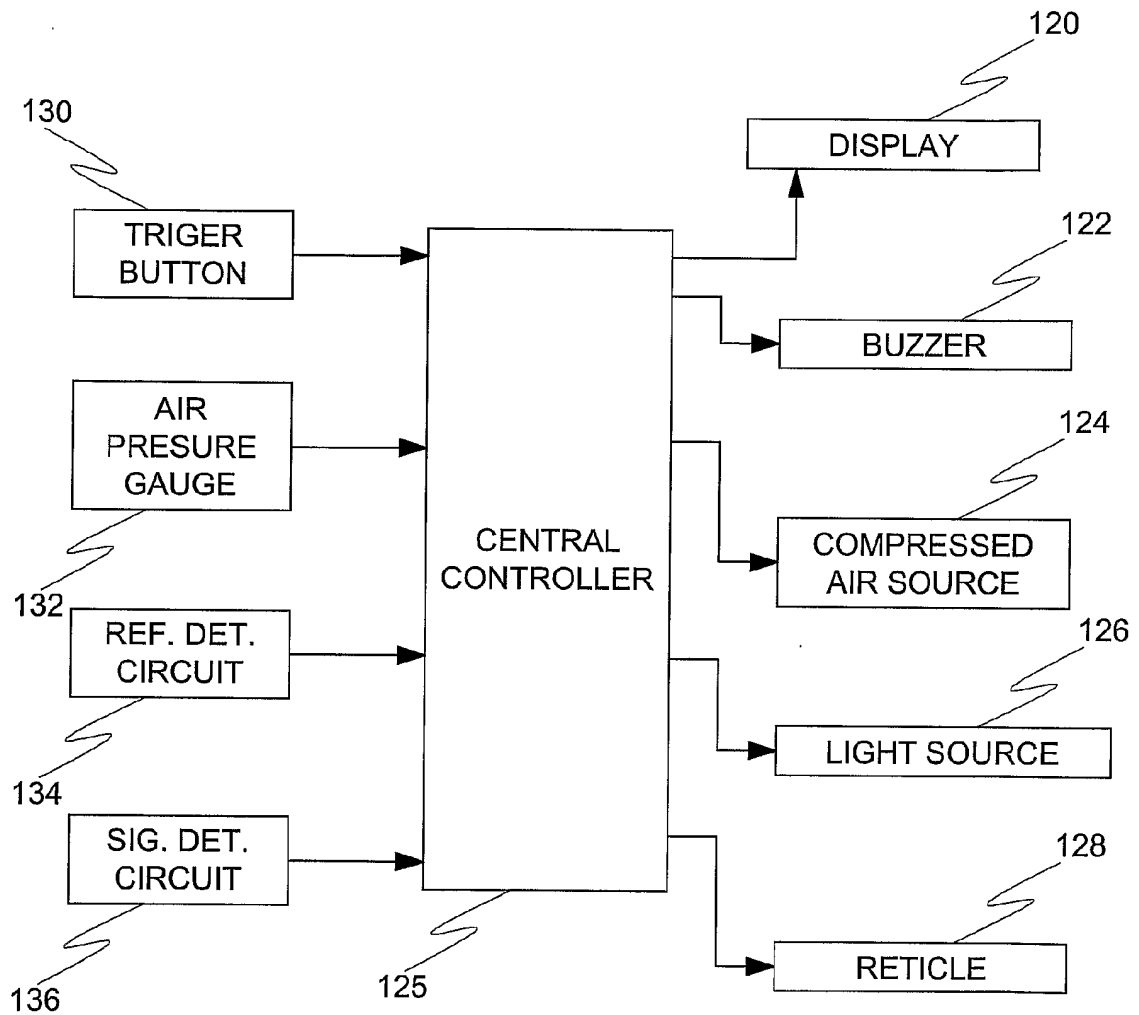

Fig. 4