

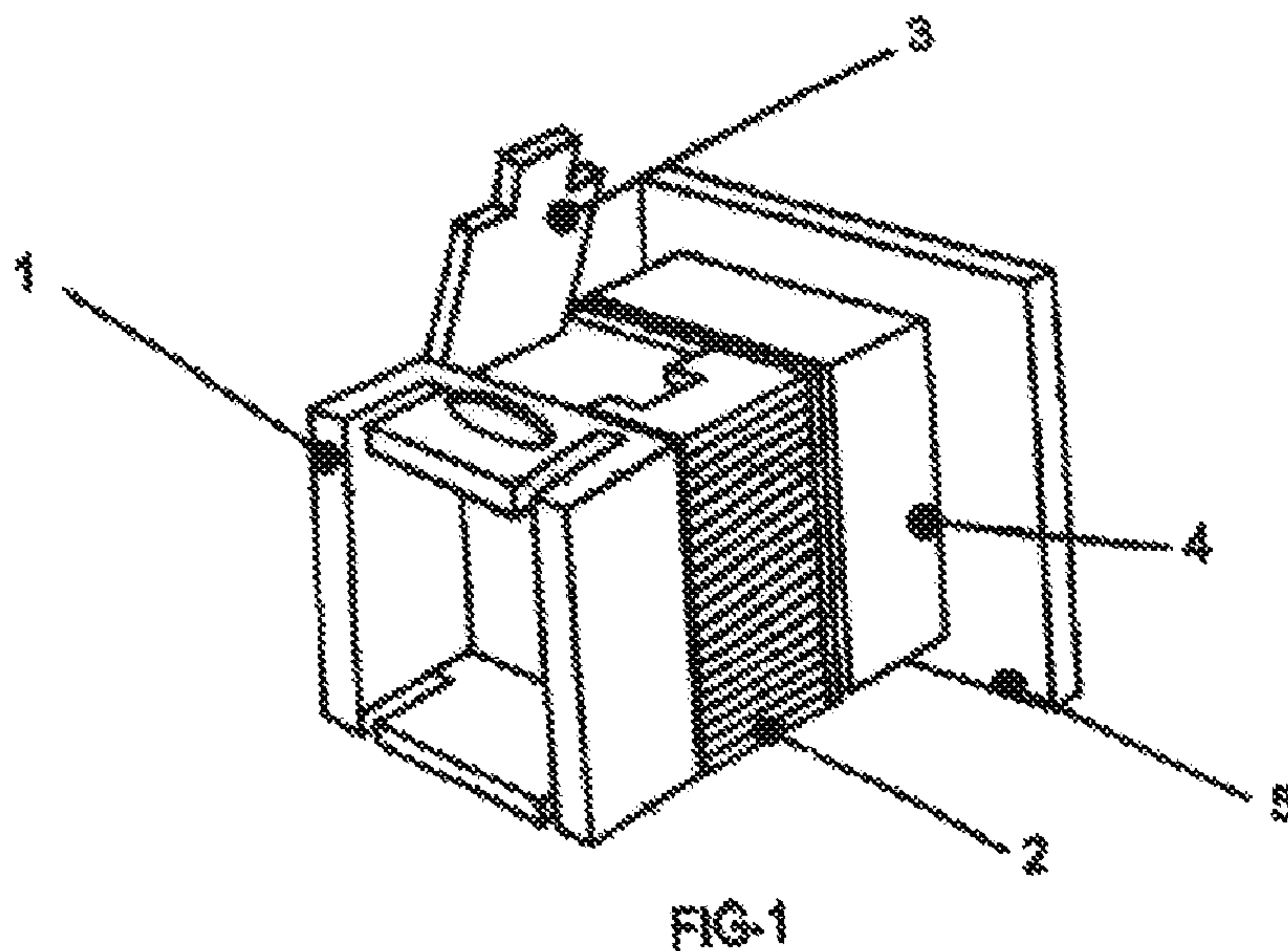

(86) Date de dépôt PCT/PCT Filing Date: 2015/11/18
(87) Date publication PCT/PCT Publication Date: 2016/06/09
(85) Entrée phase nationale/National Entry: 2017/05/19
(86) N° demande PCT/PCT Application No.: ES 2015/000170
(87) N° publication PCT/PCT Publication No.: 2016/087688
(30) Priorité/Priority: 2014/12/05 (ES P201401023)

(51) Cl.Int./Int.Cl. *B65D 5/74* (2006.01)
(71) Demandeur/Applicant:
OLEUMSTEEL, SL, ES
(72) Inventeurs/Inventors:
MORAL PAJARES, JUAN, ES;
CABRERA CASTRO, FRANCISCO, ES
(74) Agent: GOWLING WLG (CANADA) LLP

(54) Titre : BOUCHON POUR EMBALLAGE DE TYPE BRIQUE AVEC ENTREE D'AIR
(54) Title: STOPPER FOR A BOX-TYPE CONTAINER WITH AIR ADMISSION



(57) Abrégé/Abstract:

The invention relates to a stopper for a brik-type container with air admission, consisting of four parts: a stopper (1), a seal (2), a mouth (4) and a movable part (10). When the seal (2) is removed by pulling the tongue (3), the stopper (1) can be inserted into the



(57) **Abrégé(suite)/Abstract(continued):**

mouth (4) and move the movable part (10), producing two elements, one (22) for air admission and one (23) for the outflow of the liquid, in both cases perforating the plastic-aluminium film (25). Pulling the stopper (1) outwards, the fingers of the user pressing on the digital fingerprints (6), the mouth (4) opens, releasing the clip (7) of the stopper and pouring the liquid out of the brik-type container without splashing or continuous gushing of liquid.

ABSTRACT

The invention relates to a stopper for a brik-type container with air admission, consisting of four parts: a stopper (1), a seal (2), a mouth (4) and a movable part (10).
5 When the seal (2) is removed by pulling the tongue (3), the stopper (1) can be inserted into the mouth (4) and move the movable part (10), producing two parts, one (22) for the admission of air and one (23) for the outflow of the liquid, in both cases perforating the plastic-aluminum film (25). By pulling the stopper (1) outwards, the fingers of the user pressing on the fingerprints (6), the mouth (4) opens, releasing the clip (7) of the
10 stopper and pouring the liquid out of the brik without splashing or continuous gushing of liquid.

STOPPER FOR A BRIK-TYPE CONTAINER WITH AIR ADMISSION

Object of the Invention

As indicated by the title, the invention object of the present application consists
5 of a stopper for a brik-type container with air admission, the purpose of which is to pour
out the liquid inside the receptacle without splashing or gushing.

The field of the art and scope of industrial application is comprised within the
sector of stoppers for opening and closing brik-type containers, and/or toppers in
general for mouths of receptacles through which the liquid inside same is to be poured
10 such that it flows out in an even manner.

Background of the Invention

According to the analysis of the prior art, there is currently no product having
identical or similar features.

Therefore, the object of the proposed invention provides fundamental
15 advantages for the application thereof that are not covered by other similar or
alternative means.

The stopper for a brik-type container with air admission allows the fluid
contained in the container to be poured out in an even manner and without splashing
and/or gushing.

20 Currently, all stoppers for closing brik-type containers have a pour spout with a
single mouth for the outflow of the liquid from inside same, and therefore while the
liquid flows out, air must enter to take up the space left by the liquid as it is poured out.

Since the admission of air and the outflow of the liquid occur at the same time,
an irregular flow of the liquid is generated as it flows out, which causes gushing and
25 splashing the area where the liquid is poured out such that the emptying of the brik is
not easily controlled.

According to the knowledge of the inventor, who is a skilled person in the art,
the object of the invention is novel, and due to the qualities and advantages provided,
said invention presents obvious industrial and commercial interest.

30 Description of the Invention

The stopper for a brik-type container with air admission splits the mouth for the
outflow of the liquid contained in the brik in two.

Both halves are identical, and this therefore allows admitting both air and a
volume of the liquid that is flowing out.

35 The space for the outflow in the stopper for a brik-type container with air

admission is split into two identical parts, an inner part through which the liquid flows out, and an upper part through which air is admitted. Furthermore, just as the liquid flows out directly through the opening, air is admitted through a bent tunnel-like element produced by a movable part which allows the admission of air but does not
5 allow the outflow of liquid contained in the brik.

For all this to happen, the stopper is provided with elements that allow the screwing on and cutting of the film membrane and aluminum sheet protecting the packaged liquid until it is consumed.

Furthermore, it has been envisaged that the invention is comfortable and easy
10 to use, and in the same manner it has been envisaged that the elimination and disposal thereof should also be easy and comfortable, without being an environmental hazard.

To complement the description that will be made below and for the purpose of helping to better understand the features of the invention, five sheets of drawings are attached to this specification based on which the innovations and advantages of the
15 device object of the invention will be more easily understood.

Brief Description of the Drawings

To understand the scope of the features and advantages of the object of the invention, five sheets of drawings are attached hereto that complete the description of a preferred embodiment that will be provided below, the content of said drawings being
20 merely illustrative and non-limiting.

Figure 1 depicts the stopper assembly, i.e., the seal and the mouth for admission with a base for being adhered to the brik.

Figure 2 shows the fingerprint detail for opening the stopper.

Figure 3 shows a section view of a functional scheme of the system.

25 Figures 4 and 5 show the movable part for the admission of air.

Figure 6 shows the arrangement of the stopper at the inlet of the mouth of the receptacle.

Figure 7 shows the admission mouth of the receptacle and guides of the movable part for the admission of air.

30 Figure 8 shows a view of the devices of the stopper for opening the aluminum and plastic film membrane of the brik.

Figure 9 shows device for inserting and fitting the stopper to the pouring mouth.

Figure 10 shows a section and a detail of the position of the film on brik once it is cut.

35 Figure 11 shows a view from the inner part and cavities for the admission of air

and the outflow of liquid.

Figure 12 shows a brik with a position of the stopper and cutaway view of the aluminum-plastic-film protecting the content.

FIGURE 1

5 (1) STOPPER

(2) SEAL

(3) TONGUE

(4) MOUTH

(5) BASE

10 FIGURE 2

(6) FINGERPRINT

FIGURE 3

(7) CLIP OF THE STOPPER

(8) CUTTING OF THE FILM

15 (9) INNER SPACE OF THE BRIK

FIGURE 4

(10) MOVABLE PART

(11) STRIPS

(12) BUTT END

20 (13) BOX

(14) LIFTING-PART

FIGURE 5

(15) CLOSURE

FIGURE 6

25 (16) CUTTING PART

(17) PUSHING PART

FIGURE 7

(18) GUIDES

FIGURE 8

30 (19) TOOTHING

FIGURE 9

(20) SLOT

FIGURE 10

(21) SMALL BENT SHEETS

35 FIGURE 11

(22) PART FOR THE ADMISSION OF AIR

(23) PART FOR THE OUTFLOW OF LIQUID

(24) ADHESIVE

FIGURE 12

5 (25) FILM

Description of a Preferred Embodiment

It can be seen in Figure 1 that the stopper (1) is the part that is manipulated and used to open and close the mouth (4) for the outflow of liquid.

10 Before being opened, the stopper (1) is attached to the mouth (4) by means of a seal (2) having a tongue (3).

By pulling on it, the precuts between the seal (2) and the stopper (1) are broken on both sides with the mouth (4) the stopper (1) being detached and the mouth (4) being opened.

15 The mouth (4) is integral with a base (5) that is glued to the cardboard of the brik-type container.

Figure 2 shows that in order to take the stopper (1) out of the mouth (4) and put it back in, said stopper (1) has fingerprints (6) where, for greater comfort, the index finger and thumb of the user are placed in the concave shape of said fingerprints (6) to more readily remove the stopper (1) by making a riser.

20 Figure 3 shows that the stopper (1) for closing the mouth (4) is clipped on by gentle pressure into the mouth (4), and as a result of the bending of the plastic material of said stopper, its perimetral rib is clipped in the riser of the mouth (4).

25 When the stopper (1) is inserted in the mouth (4), it breaks the plastic film (25), cutting the film (8) inside and thereby provides passage and access to extraction thereof from the inner space of the brik (9).

Figure 4 shows that the movable part (10) is pushed by the stopper (1) into the container when the latter is closed, which generates a tunnel for the admission of air.

The movable part (10) moves on strips (11) integral with the butt end (12) which is where it is supported and pushed into the stopper (1).

30 The box (13) of said movable part (10) has a lifting-type part (14) to prevent the cut plastic film from going back and plugging up the opened hole.

35 Figure 5 shows that the box (13) has a closure (15) in the rear part of the movable part (10) preventing the liquid from inside the brik from filling up said box (13), and it therefore allows only air to be admitted into the brik through the upper part of the box (13) while liquid is being emptied out as it is poured.

Figure 6 shows that the inner part of the stopper (1) has two elements integral therewith, i.e., the pushing element (17) which acts by moving the movable part (10) into the container, and the cutting part (16) of the film of the brik that makes the hole through which the liquid inside the container is poured out.

5 Figure 7 shows that the guides (18) will lead the movable part (10) into the container along the length of the box of the entry of the mouth (4) and on both sides thereof and in a parallel and longitudinal manner.

Figure 8 shows that the cutting of the inner film of the brik which contains and is impermeable to the liquid is done with the cutting part (16) provided on the front profile thereof with tothing (19) giving rise to the opening for emptying out the liquid inside the brik when said brik is tilted over a glass or mug. This hole is located in the lower part of the mouth (4) whereas the volume of liquid that is emptied out is replaced with the air that is admitted through the upper part of the mouth (4), without liquid being able to flow out through it, despite the tilting of the brik in order to pour it out.

10 Figure 9 shows that once the required pouring service has been performed and to cover the mouth (4) of the brik along the four sides of the front perimeter of said mouth, it is provided with a slot (20) that allows the stopper (1), by means of the clipping device (7) of the stopper in the form of a projection or riser, to be inserted into the slot (20) by bending the plastic material, the mouth (4) thus being closed.

15 Figure 10 shows that the small bent sheets (21) resulting from the cutting of the inner plastic film of the container do not prevent the admission of air into the receptacle or the pouring of the liquid as they are facing and bent into the container and extended.

Figure 11 shows that the stopper (1) glued to the cardboard of the brik at its base (5) by means of an adhesive (24) has two independent square holes having the same size, one above the other, and there is inserted through the upper hole the box (13) having an area (22) for the admission of air independent of the area (23) for the outflow of liquid, and as they are two holes of the same size, they allow the same amount of air to be admitted through the upper hole to be equal to the volume of liquid that is poured out through the mouth of the container.

20 Figure 12 shows that the film (25) containing and isolating the brik, or making it impermeable, like a leak-tight bag, is square and therefore allows access to the inside thereof without this reducing the qualities of the product conserved therein as a result of the stopper (1) which closes the entire the system for the pouring and outflow of liquid.

35

CLAIMS

1. Stopper for a brik-type container with air admission, characterized by having:
 - A stopper (1) attached to the seal (2) by means of a precut and having a
5 tongue (3) for pulling on same and tearing off said seal (2) by breaking the precut
joining stopper (1) and the seal (2) as well as the precut joining the seal (2) with the
mouth (4);
 - The mouth (4) having a flaring or base (5) for gluing the cardboard of the brik;
 - The stopper (1) having fingerprints (6) on both sides thereof for greater
10 extraction comfort;
 - For closing the stopper (1), a clip (7) of the stopper having been arranged on
the mouth (4) like a perimetral catch which, by bending of the plastic material of the
stopper, allows opening and closing by gripping the mouth (4).
2. The stopper for a brik-type container with air admission, characterized in that
15 the closing of the stopper (1) on the mouth (4) cuts the film (8), which allows access to
the inner space of the brik (9).
3. The stopper for a brik-type container with air admission, having inside the
mouth (4) a movable part (10) that is moved by means of strips (11) when it is pushed
at its butt end (12) into the brik, said movable part (10) being closed on the sides by
20 partitions forming the box (13) closed at the front part thereof by the lifting-part (14) and
the closure (15).
4. The stopper for a brik-type container with air admission, wherein the stopper
(1) has in the back a projecting or cutting part (16) and another pushing part (17) which
moves the movable part (10), provided with side strips (11) inserted into the guides (18)
25 when the stopper (1) is inserted into the mouth (4).
5. The stopper for a brik-type container with air admission, wherein the cutting
part (16) is provided with tothing (19) along the entire front edge thereof which, when
the stopper (1) is clipped and closed on the mouth (4) in the slot (20), the small bent
sheets (21) resulting from the perforation of the movable part (10) and of the cutting
30 part (16) are secured and led into the container led by the lifting-part (14).
6. The stopper for a brik-type container with air admission, wherein the movable
part (10) generates inside the mouth (4) a part (22) for the admission of air and the
cutting part (16) generates a part (23) for the outflow of liquid through the mouth (4)
glued to the brik with adhesive (24), and all this characterized in that access is
35 achieved by opening the film (25) inside the container, the outflow of liquid being

compensated with admission of air at the same time and in the same amount.

9

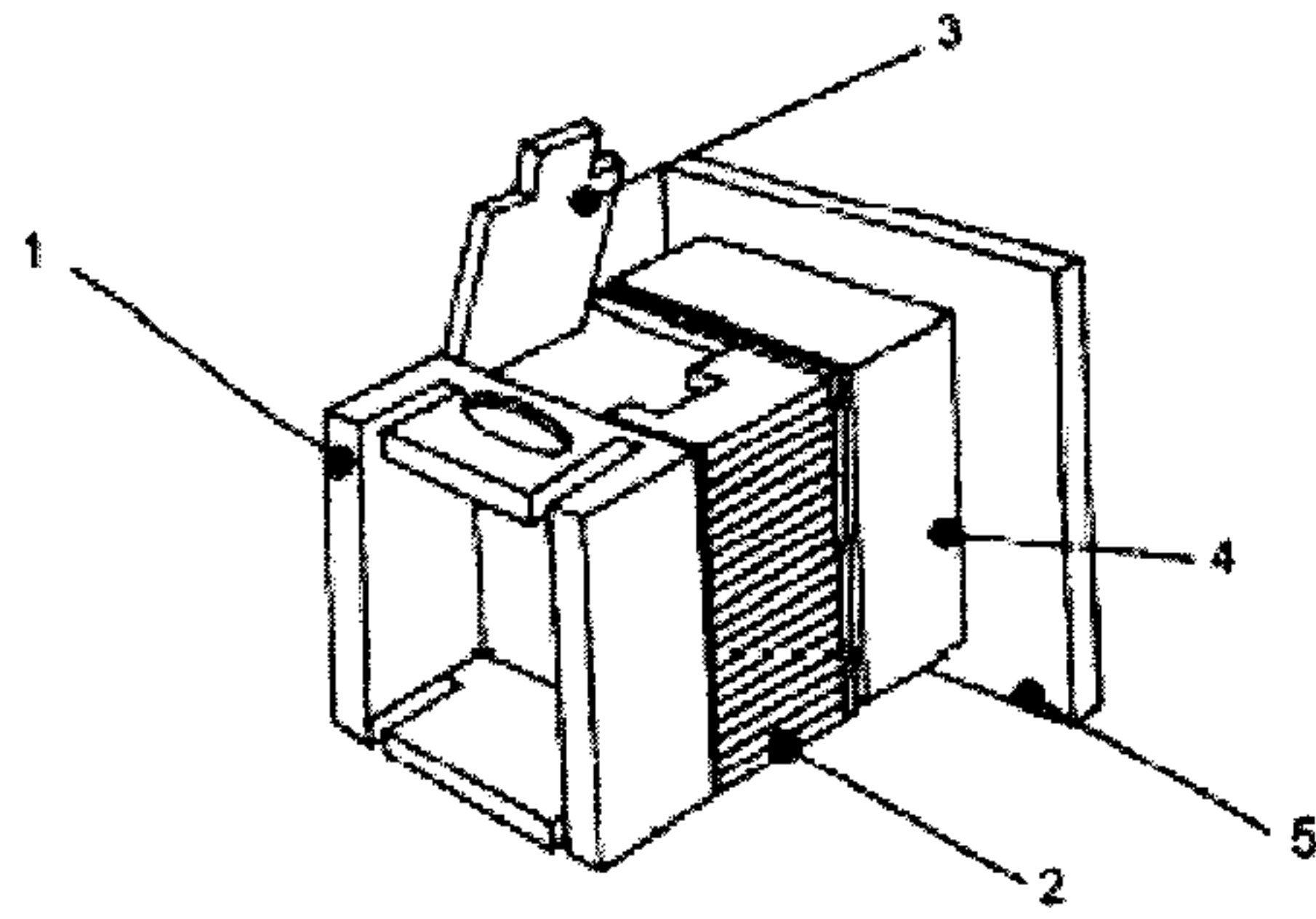

FIG-1

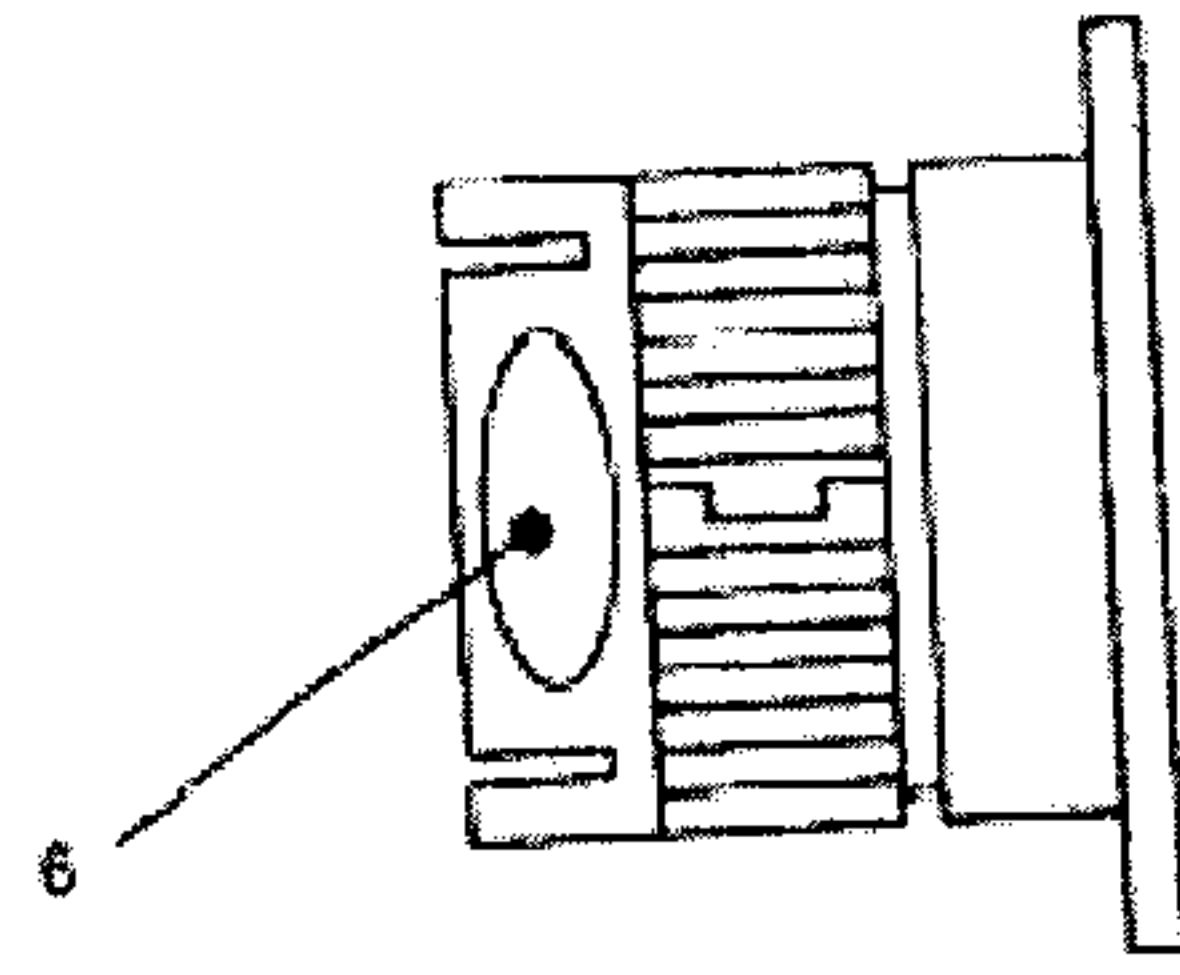

FIG-2

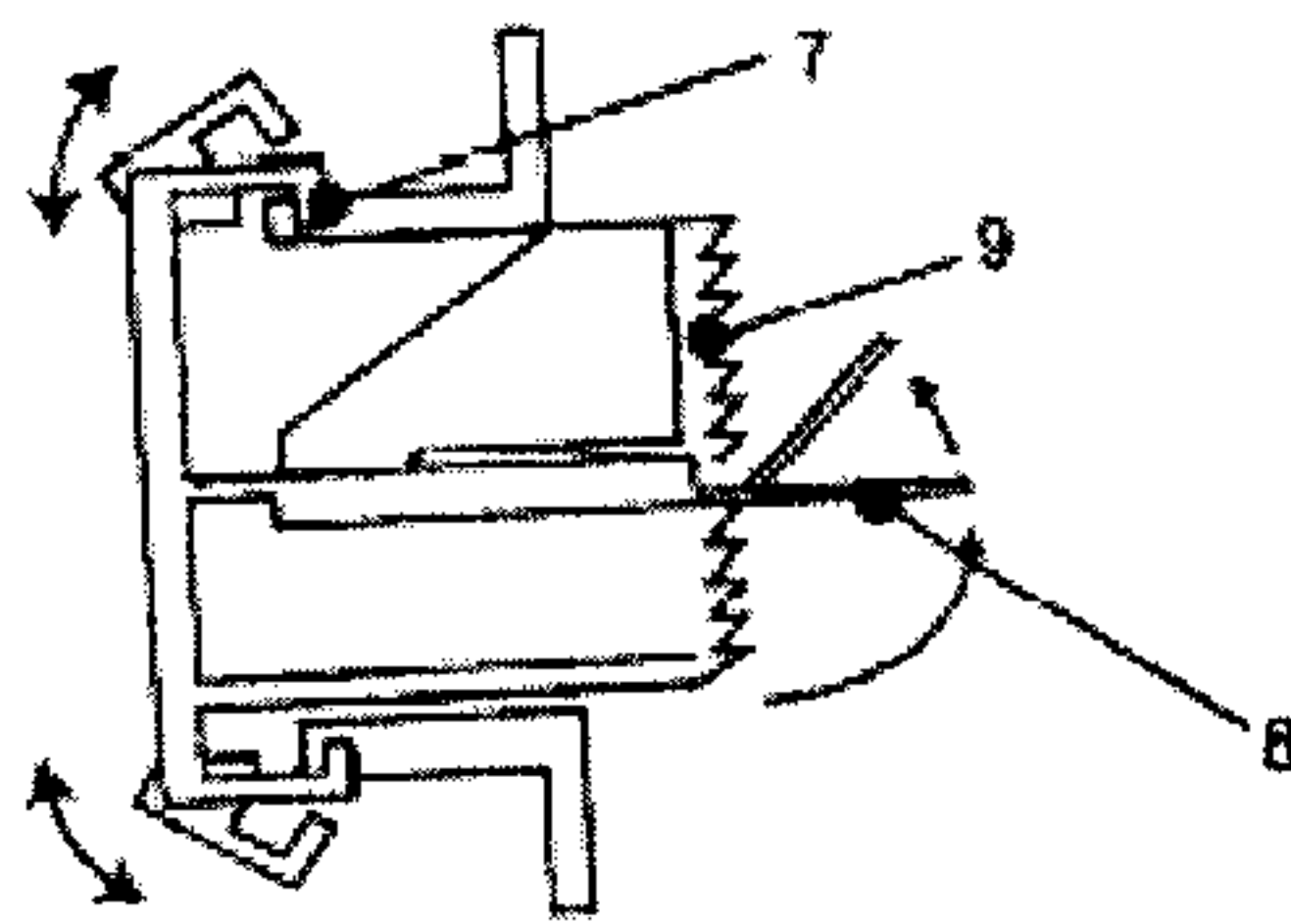

FIG-3

10

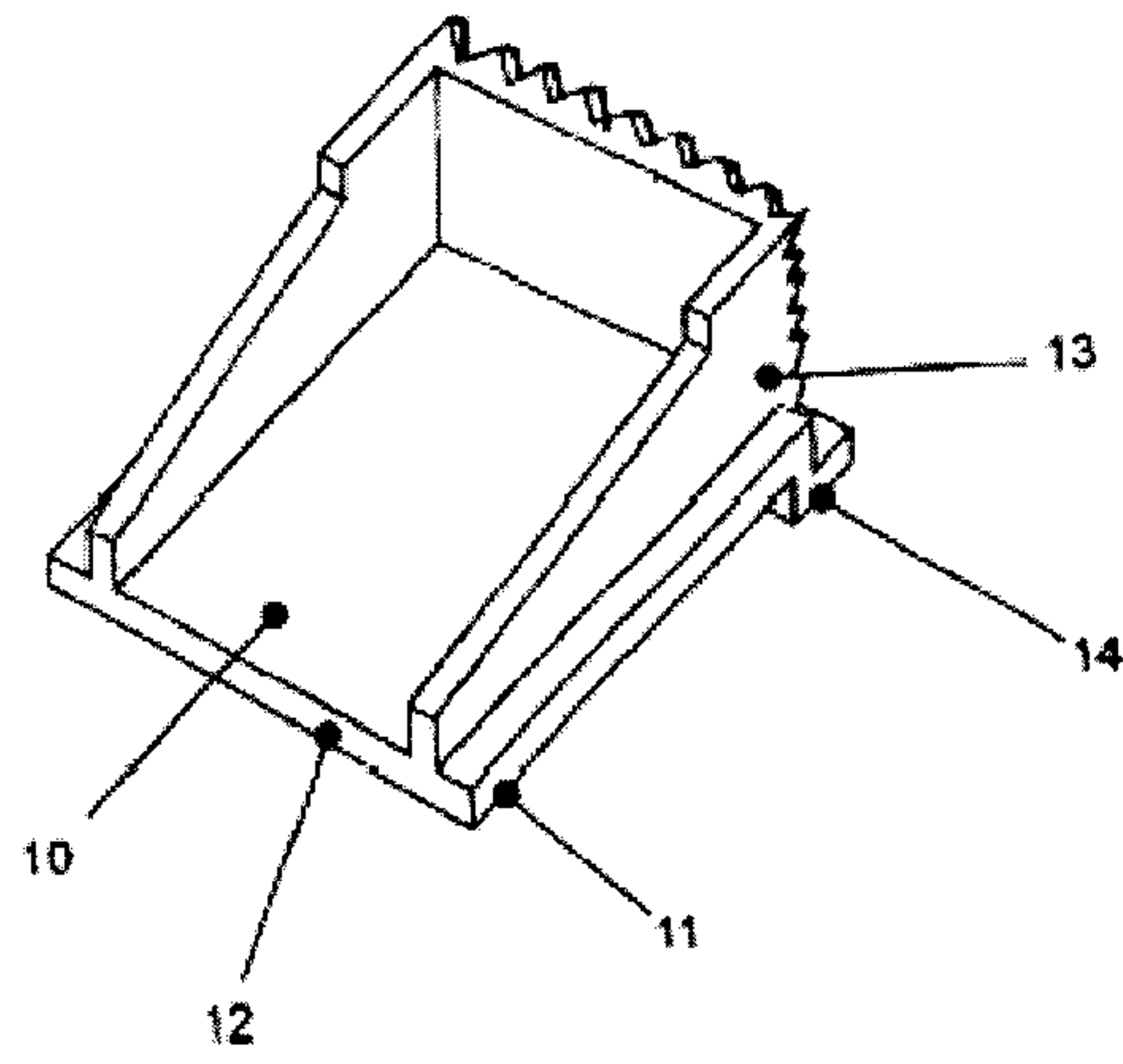

FIG-4

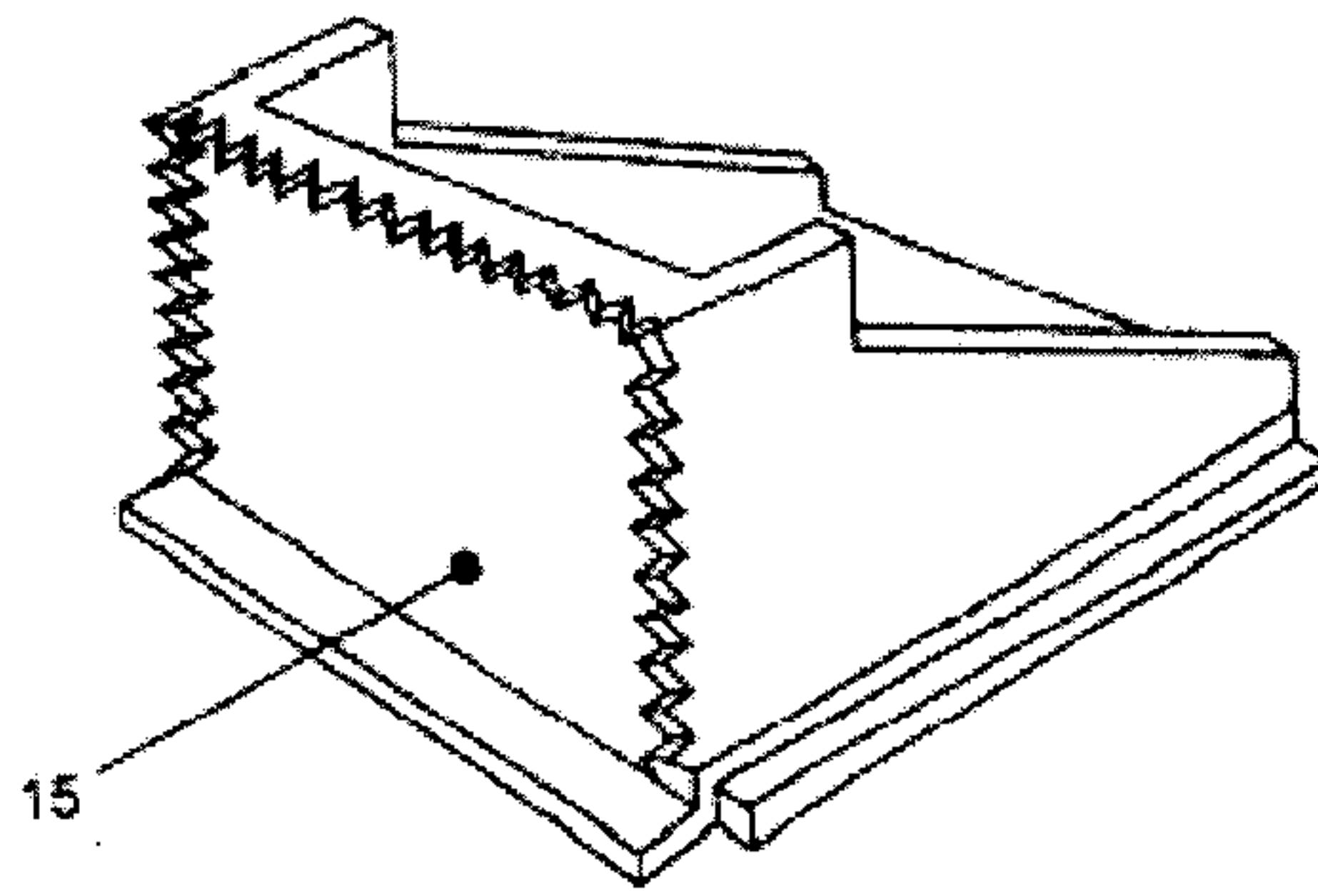
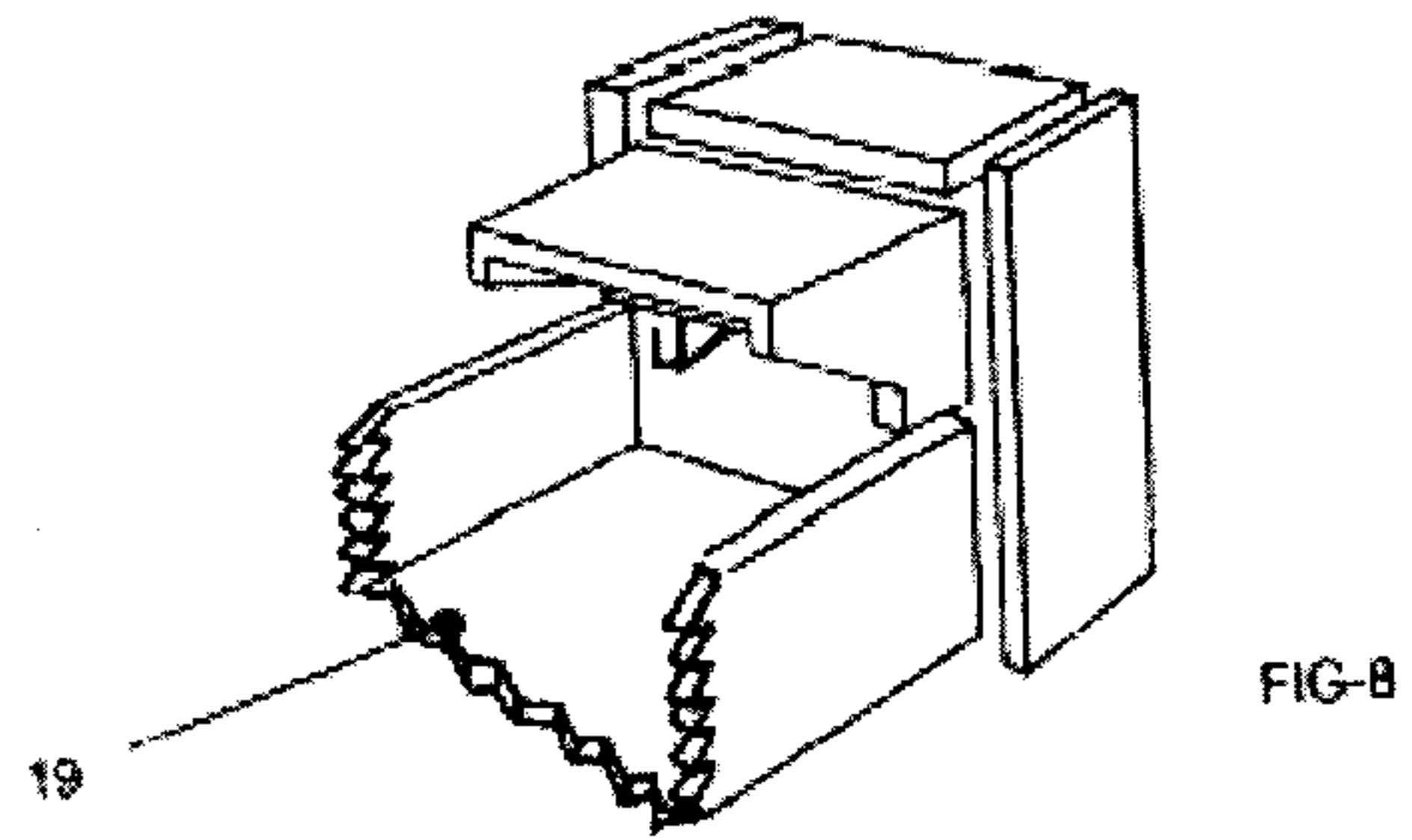
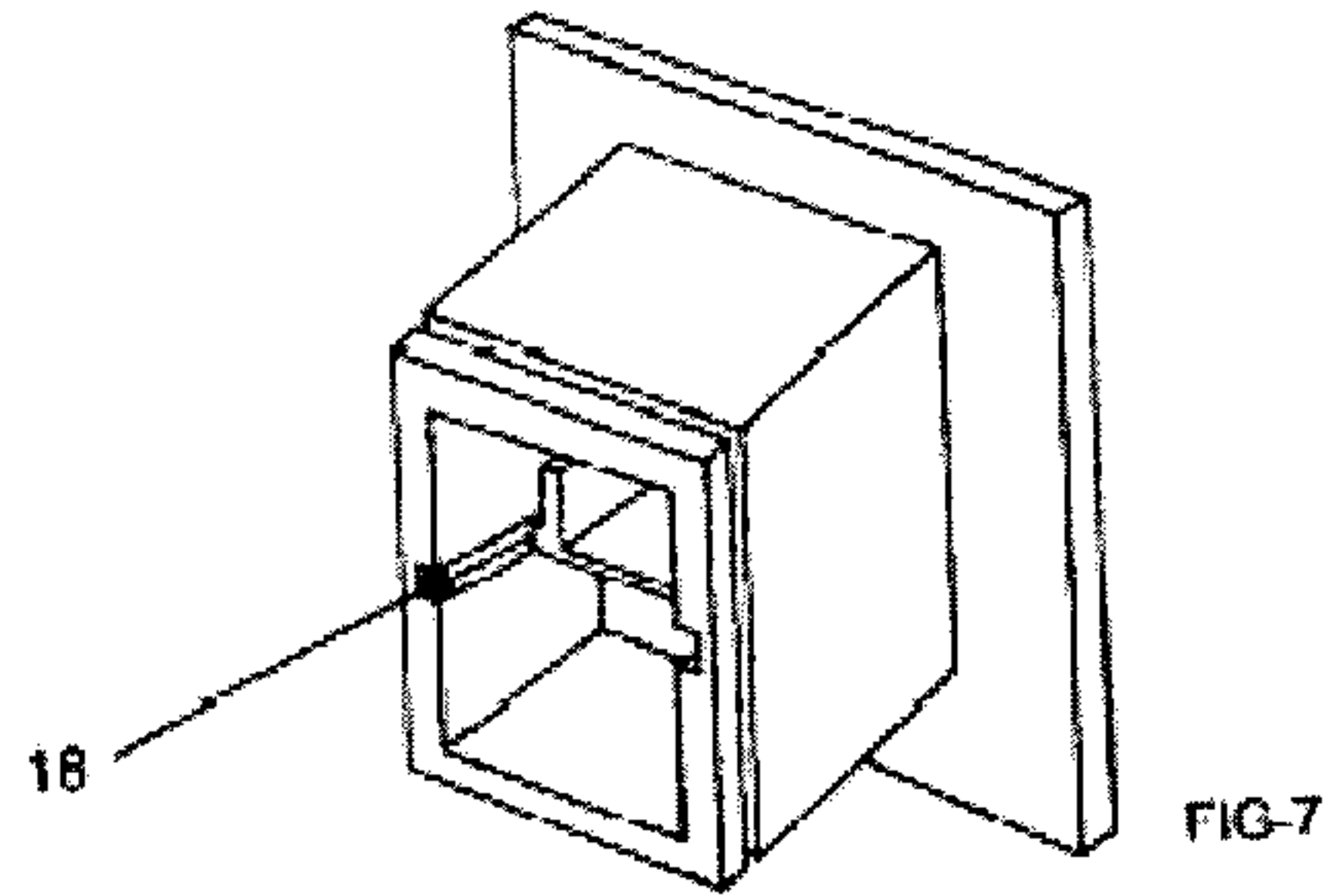
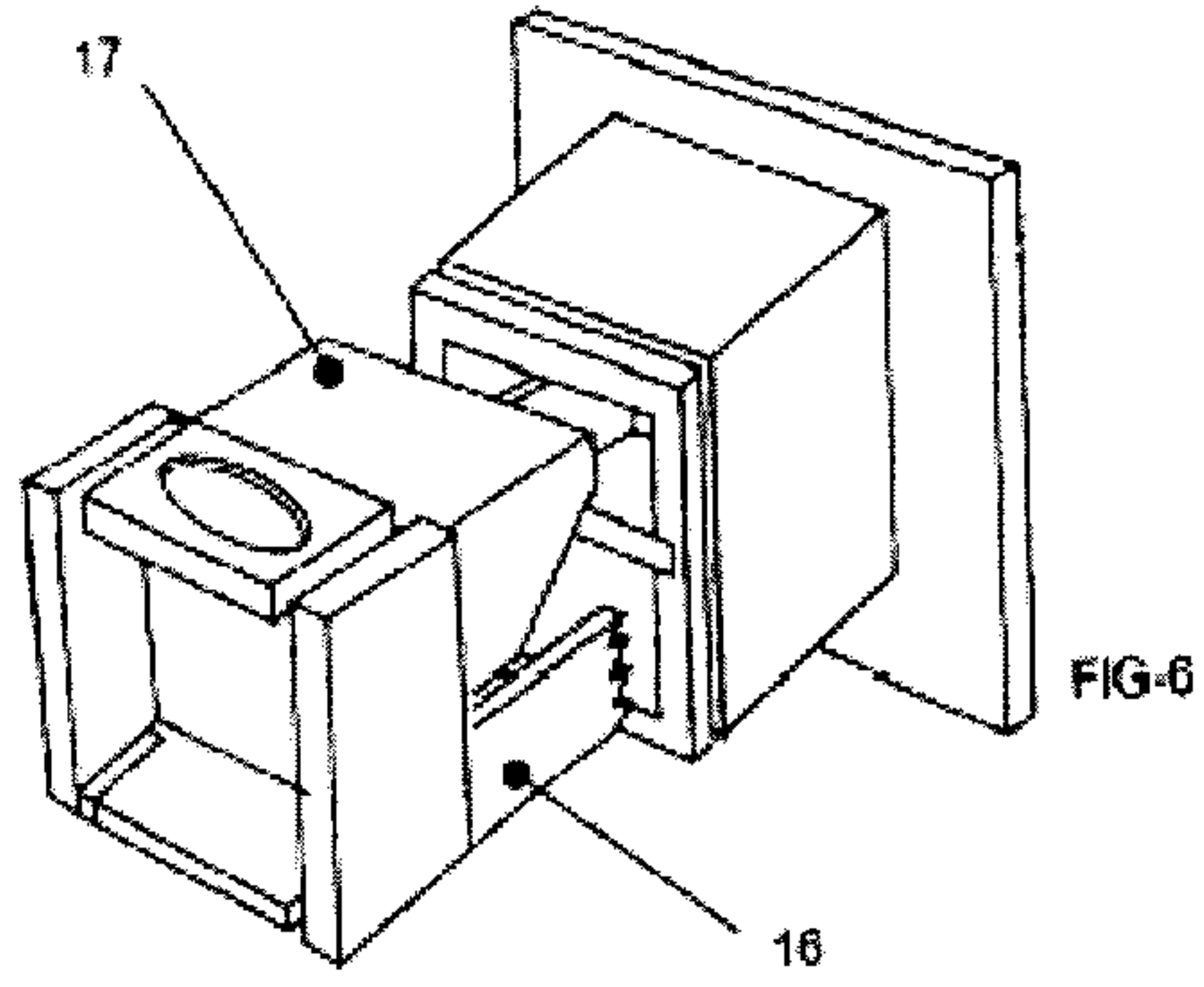
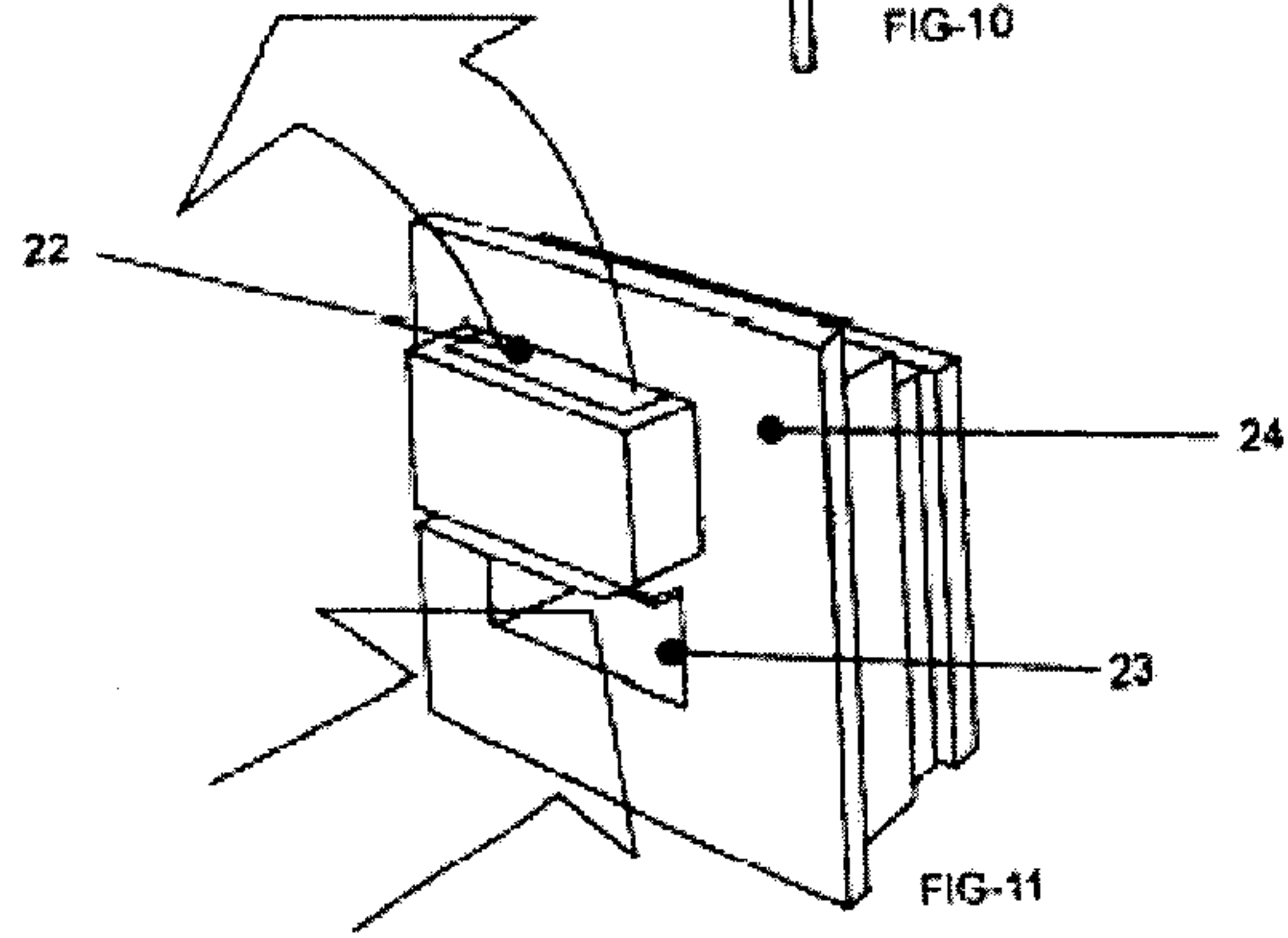
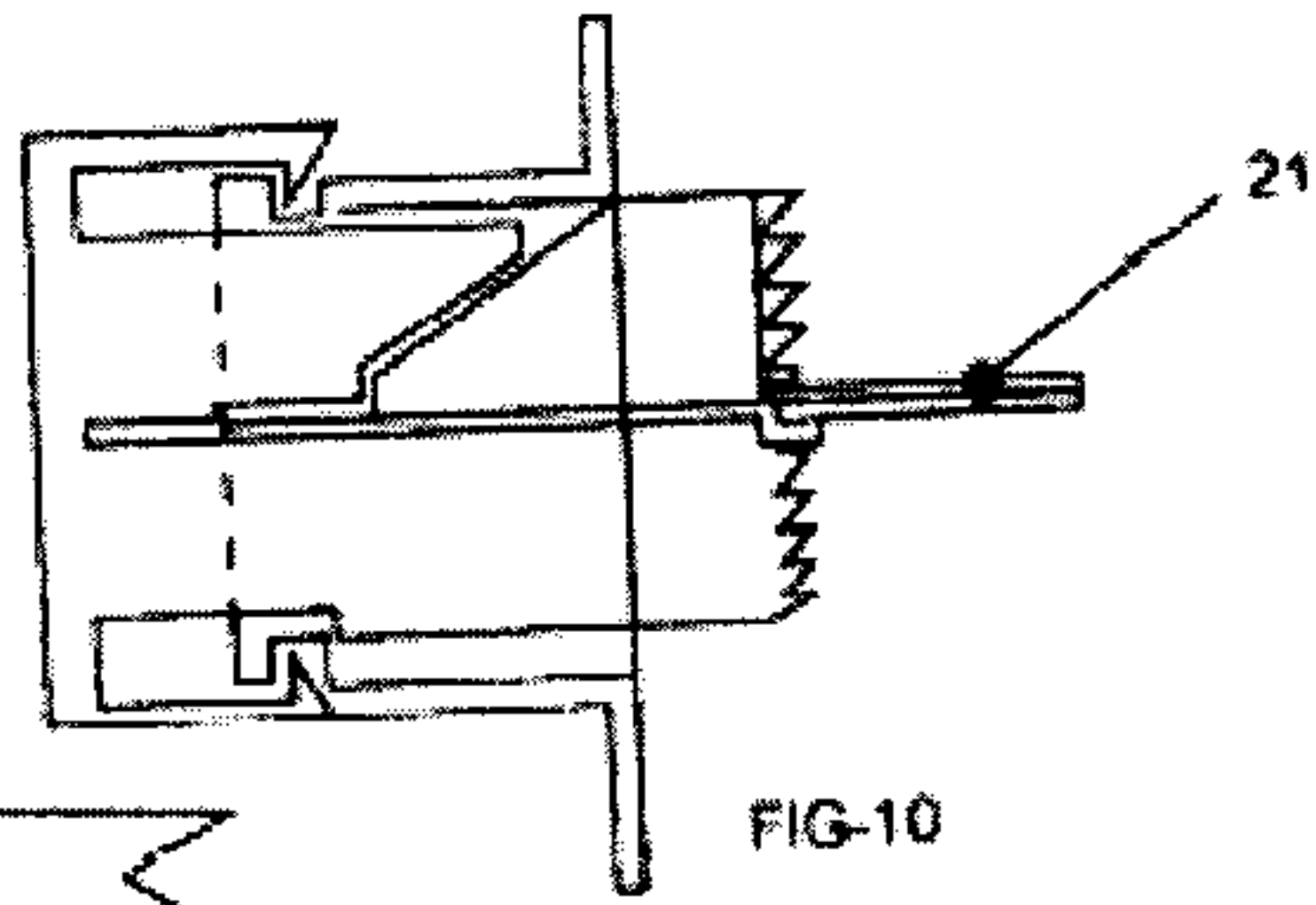
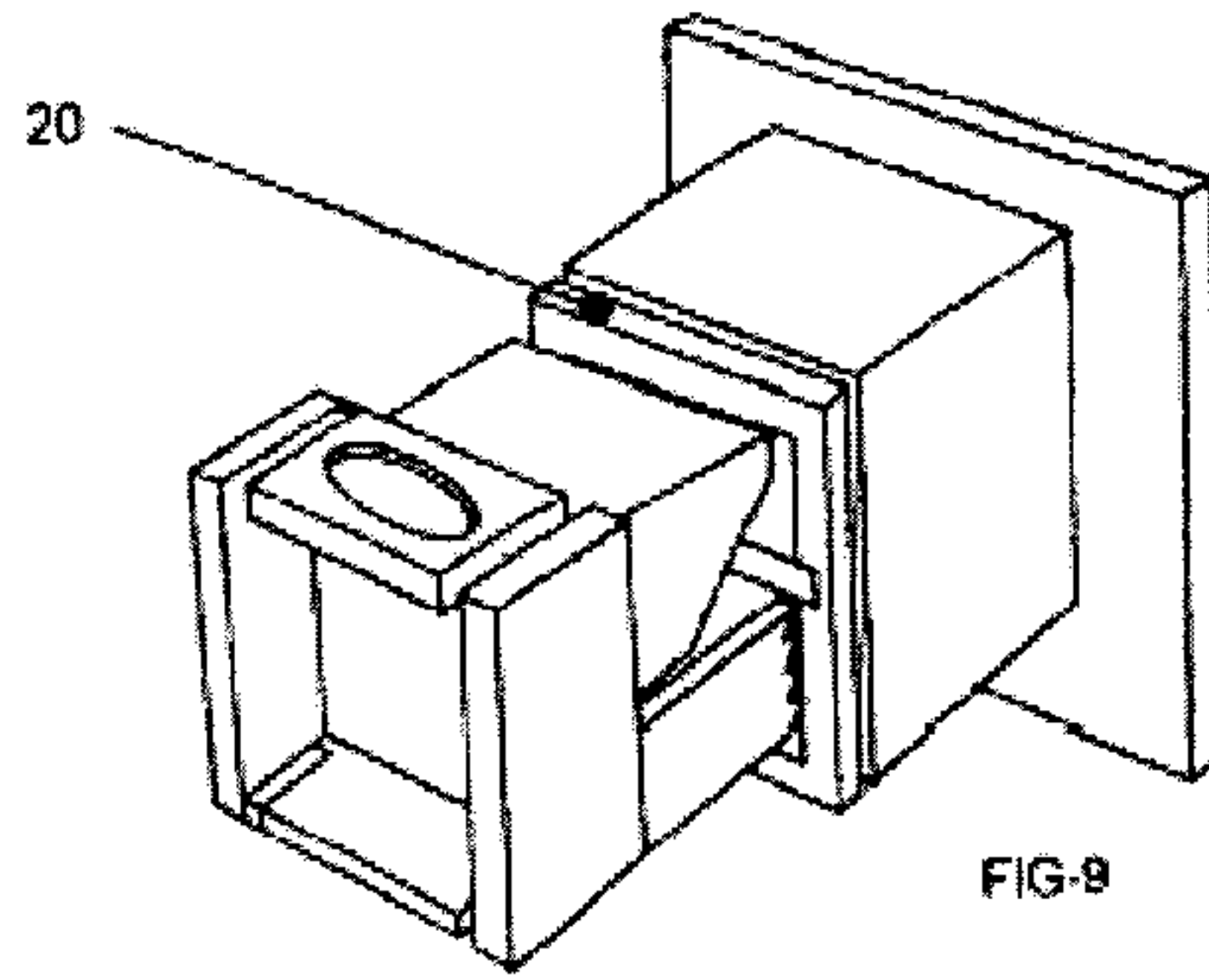

FIG-5

11



12



13

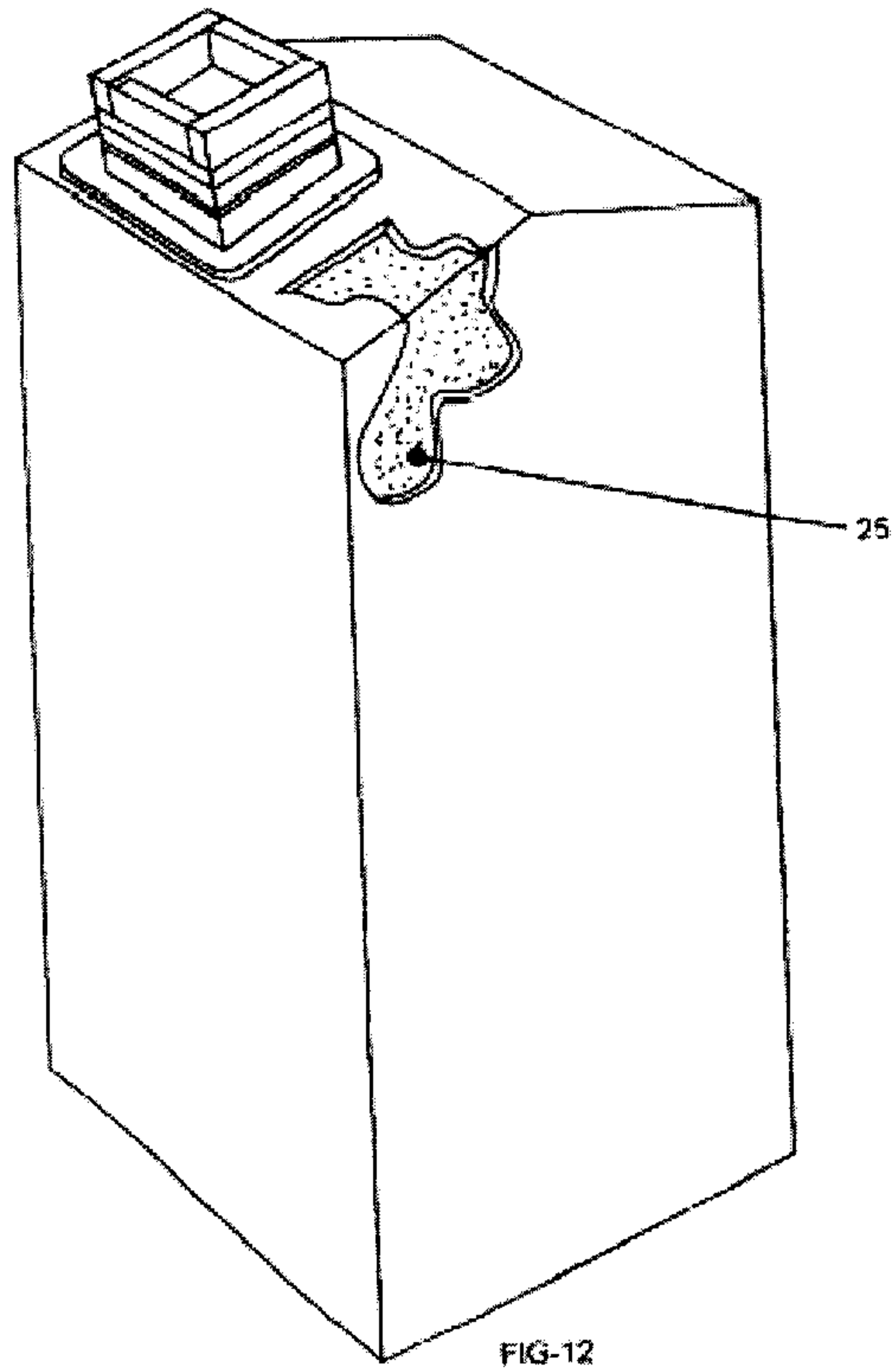

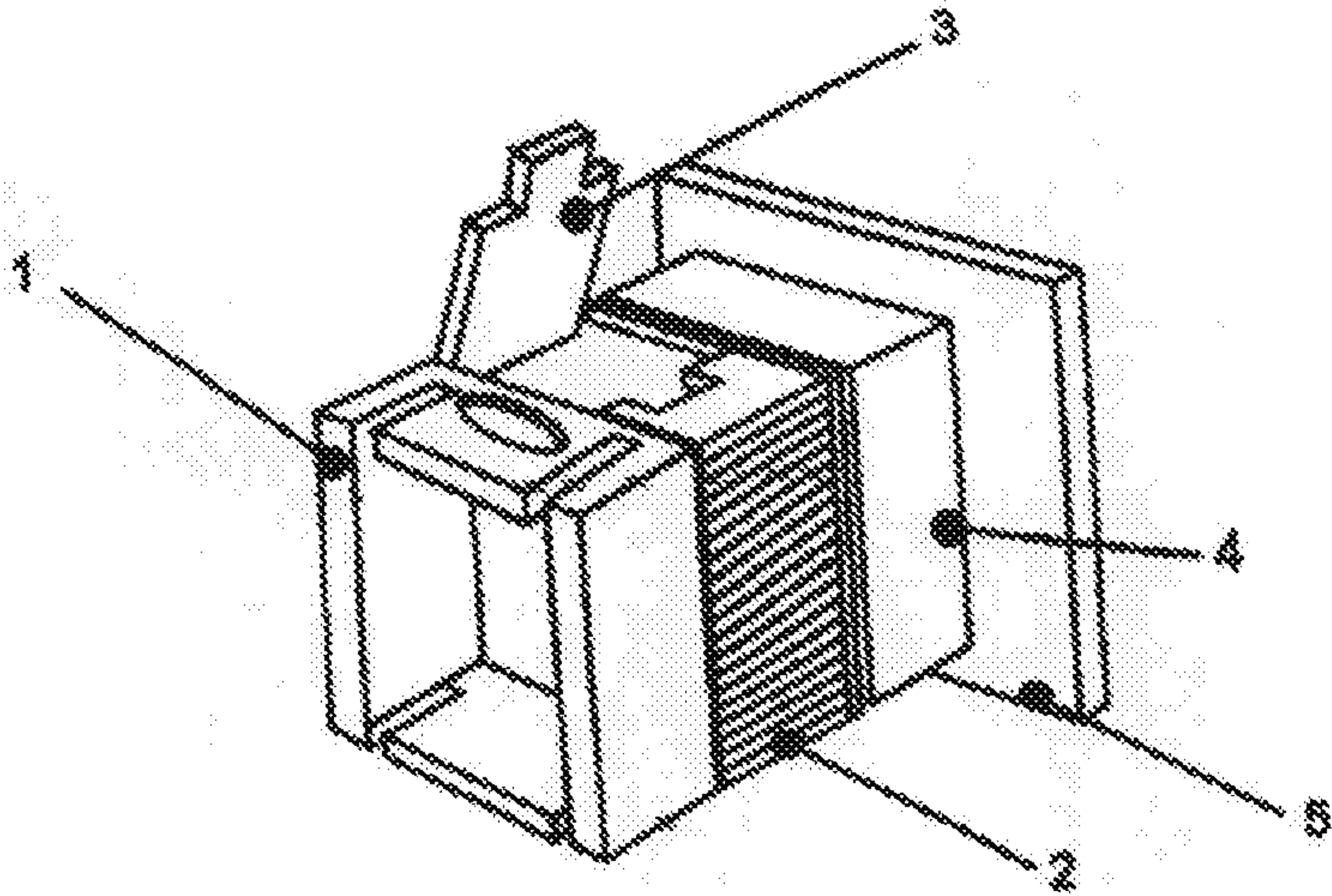

FIG. 1