

**(12) PATENT APPLICATION**  
**(19) AUSTRALIAN PATENT OFFICE**

**(11) Application No. AU 200062476 A1**

(54) Title  
**Replaceable ink cartridge for ink jet pen**

(51)<sup>7</sup> International Patent Classification(s)  
**B41J 002/175**

(21) Application No: **200062476**

(22) Application Date: **2000.10.03**

(30) Priority Data

(31) Number	(32) Date	(33) Country
<b>9413442</b>	<b>1999.10.06</b>	<b>US</b>

(43) Publication Date : **2001.04.12**

(43) Publication Journal Date : **2001.04.12**

(71) Applicant(s)  
**Lexmark International, Inc.**

(72) Inventor(s)  
**Steven Robert Komplin; David Amos Ward; Gregory Alan Long; Michael David Lattuca**

(74) Agent/Attorney  
**PHILLIPS ORMONDE and FITZPATRICK,367 Collins Street,MELBOURNE VIC 3000**

**REPLACEABLE INK CARTRIDGE FOR INK JET PEN**

**ABSTRACT OF THE DISCLOSURE**

The invention provides an ink jet pen including a cartridge body having a printhead and a replaceable ink cartridge removably positionable on the cartridge body. At least one cooperating elongate recess and at least one projection are located on the mutually facing surfaces of the ink cartridge and the cartridge body. The projection and recess are engageable with one another for guidably positioning the ink cartridge to a desired position relative to the cartridge body.

5

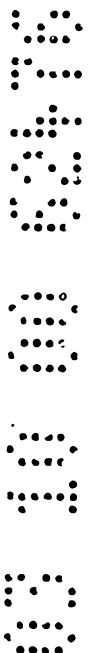

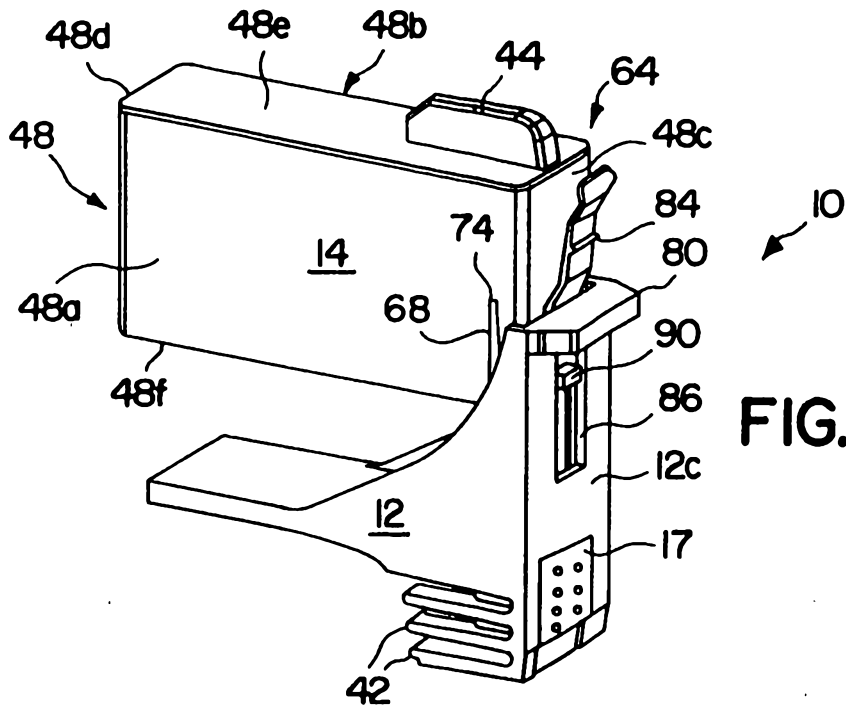

FIG. 1

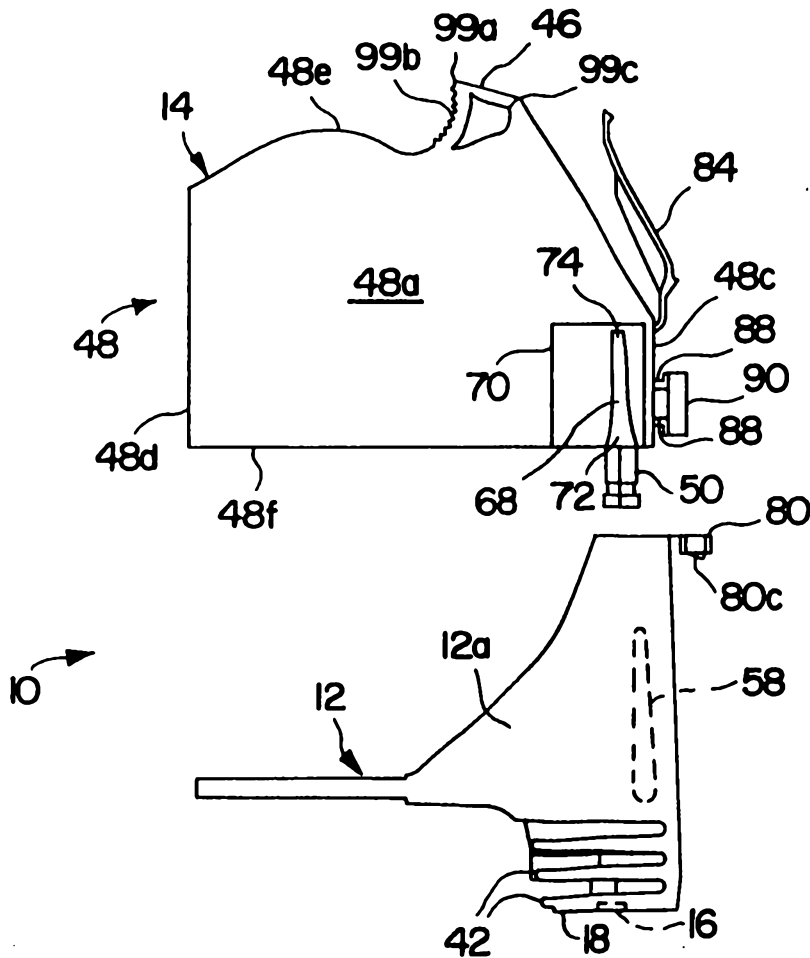

FIG. 2

**AUSTRALIA**

Patents Act

**COMPLETE SPECIFICATION  
(ORIGINAL)**

Application Number: \_\_\_\_\_ Class \_\_\_\_\_ Int. Class \_\_\_\_\_  
Lodged: \_\_\_\_\_

Complete Specification Lodged: \_\_\_\_\_  
Accepted: \_\_\_\_\_  
Published: \_\_\_\_\_

Priority \_\_\_\_\_

Related Art: \_\_\_\_\_

---

Name of Applicant:

Lexmark International, Inc.

Actual Inventor(s):

STEVEN ROBERT KOMPLIN, MICHAEL DAVID LATTUCA, GREGORY ALAN LONG,  
DAVID AMOS WARD

Address for Service:

PHILLIPS ORMONDE & FITZPATRICK  
Patent and Trade Mark Attorneys  
367 Collins Street  
Melbourne 3000 AUSTRALIA

Invention Title:

REPLACEABLE INK CARTRIDGE FOR INK JET PEN

Our Ref : 627249  
POF Code: 321975/321975

The following statement is a full description of this invention, including the best method of performing it known to applicant(s):

# REPLACEABLE INK CARTRIDGE FOR INK JET PEN

## FIELD OF THE INVENTION

The invention relates to ink jet printers and in particular to ink jet pens and their components.

## BACKGROUND OF THE INVENTION

Thermal ink jet printers are increasingly incorporating permanent or  
5 semi-permanent ink jet pens having replaceable ink cartridges. These pens are characterized as having a replaceable ink cartridge and permanent or semi-permanent components, typically a cartridge body having a TAB circuit and a printhead. The lower end of the ink cartridge usually includes an ink filter for filtering and conducting ink from the ink cartridge to the printhead. When the  
10 ink is depleted, replacing the depleted ink cartridge with a fresh ink cartridge extends the life of the pen.

It is important to the operation of the ink jet pen that the fresh ink cartridge be properly seated on the cartridge body. Otherwise, leakage of ink, introduction of air into the ink cartridge and other problems associated with  
15 replacement of the ink cartridge may result.

Accordingly, there is a need in the art for improved ink jet pen components for use with ink jet pens.

Another object of the invention is to provide an improved ink jet pen of the type having a replaceable ink cartridge.

20 An additional object of the invention is to provide an improved ink cartridge.

A further object of the invention is to provide devices of the character described which facilitate replacement of ink cartridges and aid in providing ink jet pens of improved reliability and performance.

Yet another object of the invention is to provide devices of the character described which are uncomplicated in configuration and convenient to use.

Still another object of the invention is to provide a method for extending the life of an ink jet pen.

Another object of the invention is to provide a method of replacing an ink cartridge on an ink jet pen.

#### SUMMARY OF THE INVENTION

With regard to the foregoing and other objects and advantages, the invention relates to an improved ink jet pen.

In accordance with a preferred embodiment of the invention, the pen includes a cartridge body having a printhead and a replaceable ink cartridge removably positionable on the cartridge body. Cooperating elongate recesses and projections are located on the ink cartridge and the cartridge body. The projections and recesses are engageable for guidably positioning the ink cartridge to a desired position relative to the cartridge body.

In another aspect, the invention relates to a method for replacing an ink cartridge on an ink jet pen.

In a preferred embodiment, the method includes the steps of providing a cartridge body having a printhead and a replaceable ink cartridge, the printhead and the ink cartridge having cooperating d recesses and projections engageable

with one another. The ink cartridge and the cartridge body are moved relative to one another to engage the projections and recesses and seat the ink cartridge on the cartridge body so that ink within the ink cartridge is in flow communication with the printhead.

5 In still another aspect of the invention, the invention relates to A replaceable ink cartridge for use with an ink jet pen of the type having a semi-permanent or permanent cartridge body containing a printhead and positionable on the cartridge body.

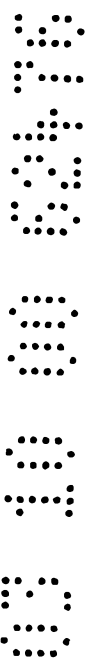

10 In a preferred embodiment, the replaceable ink cartridge includes a body portion defining a reservoir and containing ink within the reservoir, an outlet port defined on the body portion and in flow communication with the reservoir, the port being placeable in flow communication with the printhead when the ink cartridge is installed on the cartridge body, and a structure substantially aligned with a substantially vertical length axis of the ink cartridge and defined on one or more exterior surfaces of the ink cartridge. The structure of the ink cartridge is positionable during installation of the ink cartridge on a cartridge body so as to be engageable with one or more portions of the cartridge body for guidably positioning the ink cartridge to a desired position relative to the cartridge body when the ink cartridge is installed on the cartridge body.

20 The invention advantageously facilitates replacement of ink cartridges of ink jet pens.

## BRIEF DESCRIPTION OF THE DRAWINGS

Further advantages of the invention will become apparent by reference to the detailed description when considered in conjunction with the figures, which are not to scale, wherein like reference characters indicate like elements through the several views and wherein:

Fig. 1 is an exploded front perspective view of an ink jet pen in accordance with a preferred embodiment showing a replaceable ink cartridge being positioned on a cartridge body;

Fig. 2 is an exploded side elevational view of an ink jet pen according to the invention;

Fig. 3 is a rear perspective view of the cartridge body of the pen of Fig. 1;

Fig. 4 is an enlarged side view of a latching member portion of an ink cartridge of the pen of Fig. 2;

Fig. 5 is an exploded rear perspective view of an ink jet pen in accordance with the invention having multiple ink cartridges;

Fig. 6 is a front perspective view of the pen of Fig. 5 having the ink cartridges installed on cartridge bodies;

Fig. 7 is a perspective view of the cartridge body of the pen of Fig. 5;

Fig. 8 is a top plan view of the cartridge body of Fig. 7;

Fig. 9 is a side perspective view of ink cartridges of the pen of Fig. 5;

Fig. 10 is an exploded front perspective view of an ink jet pen in accordance with another embodiment of the invention;



Fig. 11 is a rear exploded view of the pen of Fig. 10;

Fig. 12 is a front perspective view of the pen of Fig. 10 in an assembled state;

Fig. 13 is a rear perspective view of the pen of Fig. 12;

5 Fig. 14 is front perspective view of ink cartridges for an ink pen in accordance with another embodiment of the invention;

Fig. 15 is a rear perspective view of the ink cartridges of Fig. 14;

Fig. 16 is a rear exploded view in perspective of the ink pen of Fig. 16;

10 Fig. 17 is a front perspective view of an ink pen containing the ink cartridges of Fig. 14;

Fig. 18 is an exploded cut-away view of the ink pen of Fig. 16;

Fig. 19 is an exploded view in perspective of an ink cartridge refilling system; and

15 Fig. 20 is a perspective view of an ink cartridge cover containing an adapter for refilling the cartridge with ink according to the invention.

#### **DETAILED DESCRIPTION OF THE INVENTION**

20 The invention relates to ink jet pens of the type having disposable components and permanent or semi-permanent components. The components of the pen are advantageously configured to facilitate replacement of the disposable components. Accordingly, and with reference to Figs. 1-4, there is shown an ink jet pen 10 and the components thereof including a permanent or semi-permanent cartridge body 12 attachable to a replaceable ink cartridge 14

for providing ink to an ink jet printhead 16 connected to a TAB circuit, such as circuit 17.

The cartridge body 12 may be configured to hold a single ink cartridge or to hold multiple ink cartridges, preferably of different color inks. In the case of a single ink cartridge 14, the cartridge body 12 preferably contains a single printhead 16 adjacent a lowermost surface 18 of the cartridge body 12 opposite the ink cartridge 14.

In the case of multiple cartridges or multicolor cartridges, as shown in Figs. 5-9, one or more cartridge bodies 20 may be provided and configured to contain multiple ink cartridges 22, 24, 26 and 28 and multiple printheads 30, 32, 34 and 36, connected to TAB circuits or flexible circuits 37, 38, 39 and 40.

The embodiment of Figs. 10-13 shows a single ink cartridge having a plurality of separate ink chambers therein, preferably 3 or 4 ink chambers, each ink chamber containing a different color ink, and a cartridge body having a corresponding number of printheads, i.e., one for each ink color.

In high speed, high quality printing operations, it is preferred that the cartridge bodies be adapted to remove heat from the printheads attached thereto. This may be accomplished by constructing the cartridge body out of a heat conducting metal such as aluminum, stainless steel, zinc, and other metals and alloys and/or as by providing heat conducting fins 42 on the cartridge body 12 or fins 42' on the cartridge body 20 (Fig. 7) to conduct heat away from the printhead by conduction and convection. The ink cartridge 14 is typically

made of a polymeric thermoplastic material, such as polyethylene or polypropylene, which is resistant to corrosion from exposure to ink.

Returning now to Figs. 1-4, the replaceable ink cartridge 14 has an upper portion containing a handle 44 (or handle 46) and a body portion 48  
5 having side surfaces 48a and 48b, front surface 48c, rear surface 48d, top surface 48e and bottom surface 48f. The handle 44 (or 46) is located on the top surface 48e.

An outlet conduit or port 50 is located adjacent the bottom surface 48f  
of the body portion 48 and is in flow communication with the interior of the  
10 body portion 14. The port 50 is placeable in flow communication with the printhead 16 by means of a needle valve to feed ink to the printhead. The outlet port 50 preferably includes or cooperates with a filter material, such as foam, for filtering ink as it travels from the ink cartridge 14 to the printhead 16.

The outlet port 50 may initially be sealed as by a ruptureable membrane  
15 or a pre-pierced elastomeric septum. The membrane is ruptured by an ink needle during installation of the ink cartridge 14 onto the cartridge body 12 when the ink cartridge 14 is seated on the cartridge body 12 to place the ink cartridge 14 in ink flow communication with the printhead 16. The needle valve assembly, described in more detail below may be received by and seated  
20 within a recess 54 in the cartridge body 12. A seal such as O-ring 56 located at the recess 54 seals against leakage of ink when the needle valve assembly is attached to the cartridge body (Fig. 3).

The cartridge body 12 and the ink cartridge 14 are mutually configured with engageable projections and recesses to improve the step of replacement of a depleted ink cartridge with a fresh ink cartridge. In this regard, the cartridge body 12 preferably includes projections, such as a pair of guide rails 58 and 60 thereon on opposite facing interior surfaces 64 and 66 of sides 12a and 12b of the cartridge body 12 (Fig. 3). The rails 58 and 60 are received by corresponding recesses, such as guide grooves or slots 68 on opposite exterior surfaces of sides 48a and 48b of the ink cartridge 14 (Fig. 2). The guide rails 58 and 60 and slots 68 cooperate for guiding substantially vertical or linear travel of the ink cartridge 14 as it is being installed on the cartridge body 12 as opposed to an initial angular orientation of the ink cartridge 14 with respect to the cartridge body 12 as the cartridge 14 is being inserted therein.

The substantially vertical or linear travel of the cartridge 14 facilitates installation of the ink cartridge to the body 12a and connection of the port 50 with recess 54 so that a substantially liquid and gas tight connection is made between the ink cartridge 14 and body 12a. For the purposes of the description, and without intending to limit the invention in any way, the term "vertical" with respect to the cartridge 14 or body 12 is intended to indicate an initial movement of the cartridge 14 in a direction substantially along an axis defined by rails 50 and 60 and/or slots 68 as the cartridge 14 is inserted in the body 12 and is not intended to indicate an absolute direction or orientation thereof. Furthermore, the term "substantially vertical" means that the ink cartridge 14 is installed on the cartridge body 12 by tilting the cartridge 14 no more than 10

degrees with respect to a vertical axis aligned with the rails 58 and 60 and slots 68. Typically the cartridge 14 is tilted no more than about 2 degrees from the vertical axis.

The slots 68 may be recessed directly into the cartridge body 14 (Fig. 1) or may be located on raised portions on the side surfaces 48a and 48b, such as raised portion 70. As will be appreciated, the slots 68 could alternatively be located on the cartridge body 12 and the rails 58 and 60 on the ink cartridge 14, or a single rail 58 or 60 may be located on one side of the cartridge body 12 and a slot 68 on an opposite side thereof, with the corresponding sides of the ink cartridge 14 having a rail and/a slot to cooperate with the slot and rail on the cartridge body 12.

The slots 68 are preferably tapered and include a relatively wide first end 72 having a width of from about 5 to about 8 millimeters and a relatively narrower second end 74 having a width of from about 3 to about 5 millimeters. The overall length of each of the slots 68 is preferably from about 30 to about 60 millimeters. The rails 58 and 60 are similarly configured so as to be fittingly and slidingly receivable within the slots 68. Each rail 58 and 60 preferably includes a relatively narrower and tapered first end 76 and a relatively wider second end 78. The relative width of the first end 72 facilitates positioning of the rails therein, with the relatively narrow first end 76 of the rails being initially positioned therein. The rails and slots cooperate to provide a snug fit when the rails 58 and 60 are fully positioned within the slots 68 so as to maintain the ink cartridge 14 in a preferred alignment with the cartridge

body 12 without additional securement. However, additional securement may be included if desired.

In this regard, front side 12c of the cartridge body 12 which is connected to sides 12a and 12b, may include a projection 80 extending outwardly and perpendicular therefrom for engaging a latch member 84 of the ink cartridge 5 14. An elongate slot or recess 86 may also be located, preferably centrally located, on the front side 12c to provide space for placement of memory support arms 88 extending from front surface 48c of the ink cartridge 14 and a memory device 90 attached, as by adhesive to the support arms 88, for 10 receiving, storing and/or transmitting alignment information, ink information, and the like to a printer control system.

As best seen in Fig. 4, the latch member 84 preferably includes a lower leg portion 92 attached to the front surface 48c and extending outwardly therefrom. An upper lever portion 94 extends upwardly from an uppermost 15 part of the leg portion 92 in a direction generally toward the handle 44 or 46. An outwardly extending finger 96 located on the front of the latch member 84 adjacent the juncture of the leg portion 92 and the lever portion 94 is engageable with a lower surface 80c of the projection 80 for removable attachment of the ink cartridge 14 to the cartridge body 14. A reinforcing 20 member 98 preferably extends between the leg portion 92 and the lever 94 for strength. The leg portion 92 is biasable toward the front surface 48c by application of pressure to the lever portion in a direction toward the handle 44 or 46. In this manner, the latch member 84 can be positioned to yieldably

engage the lower surface 80c of projection 80 for additional securement of the ink cartridge 14 on the cartridge body 12.

An advantage achieved by the invention is the enablement of one-handed installation and removal of the ink cartridge 14 from the cartridge body 12. The configuration of the handle 44 or 46 compliments this feature and in a preferred embodiment includes a curved rear surface 99a having textured surfacing or knurls 99b and aperture 99c extending through the thickness of the handle 46. As will be appreciated, a user may insert an appendage, such as a finger, into the aperture 99c and bear another appendage, such as a finger or thumb, against the knurls 99b of rear surface 99a in order to securely hold the cartridge 14 during installation and removal procedures.

Turning now to Figs. 5-9, there is shown another embodiment of an ink jet pen 100 in accordance with the invention and having multiple ink cartridges and multiple cartridge bodies, each body containing at least one printhead. As described above, the pen 100 includes cartridge body 20, ink cartridges 22, 24, 26 and 28 and printheads 30, 32, 34 and 36, connected to TAB circuits or flexible circuits 37, 38, 39 and 40.

Each ink cartridge 22, 24, 26 and 28 is preferably substantially similar in configuration to the ink cartridge 14. Accordingly, cartridge 22 includes a body portion 102 having a handle 103 outlet port 110 and latch member 118. Cartridges 24, 26 and 28 are similarly configured and include body portions 104, 106 and 108, handles 105, 107 and 109, outlet ports 112, 114 and 116, and latch members 120, 122 and 124, respectively. The ports 110-116 may be

received within recesses 54' on the cartridge body 20 in the manner described for port 50 being received into recess 54 and having an associated seal such as an o-ring 56 (Fig 3).

With further reference to Figs. 7 and 8, the cartridge body 20 includes a body portion 126 configured to receive ink cartridge 22 and a body portion 128 configured to receive the ink cartridges 24, 26 and 28. The body portions 126 and 128 may be separate or are preferably rigidly connected to one another as by fins 42'.

The body portion 126 includes sidewalls 130 and 132 having mutually facing interior surfaces 134 and 136, respectively, between which the ink cartridge 22 is positionable. Rails 138 and 140 (configured similar to rails 58 and 60) are located on surfaces 134 and 136, respectively, for receiving corresponding slots 142 (configured similar to slots 68), one each being on opposite sides of the cartridge body.

Similarly, body portion 128 includes sidewall 144, 146, 148 and 150. Ink cartridge 24 is positionable between surface 152 of sidewall 144 and surface 154 of sidewall 146. Ink cartridge 26 is positionable between surface 156 of sidewall 146 and surface 158 of sidewall 148. Ink cartridge 28 is positionable between surface 160 of sidewall 148 and surface 162 of sidewall 150. Rails 164 and 166 (configured similar to rails 58 and 60) are located on surfaces 152 and 154 for receiving corresponding slots 168 (configured similar to slots 68), one each being on opposite sides of the cartridge body 24 (Fig. 9). Similarly configured rails 170 and 172 are located on surfaces 156 and 158 for



receiving corresponding slots 174 on opposite sides of the cartridge body 26 and rails 176 and 178 are located on surfaces 160 and 162 for receiving corresponding slots 180 on opposite sides of the cartridge body 28.

With reference to Fig. 9, the slots 168, 174 and 180 are preferably staggered or offset from one another. The corresponding sets of rails 164 and 166, 170 and 172, and 176 and 178 are likewise staggered or offset so that they are not aligned with one another in a single plane parallel each set of rails. This advantageously prevents undesirable mis-seating of the ink cartridges in the wrong position with respect to a corresponding printhead. For example, the ink cartridges 24, 26 and 28 preferably contain inks of different color. Improper placement of the ink cartridges with respect to the printheads would thus cause the wrong color ink to be dispensed through the printheads. The provision of the slots and rails such that each ink cartridge can only be received in the space of the cartridge body having rails that correspond in alignment with the slots on the ink cartridge will accordingly prevent accidental mis-seating of an ink cartridge in the wrong position.

Body portion 126 also includes projection 182 and body portion 128 includes projection 184 (Fig. 7); each preferably configured similar to projection 80 for engaging latch members 118, 120, 122 and 124 of the ink cartridges 22, 24, 26 and 28. Each latch member 118-124 may be similar in configuration to the latch member 84. Elongate slots or recesses 186 and 188 are centrally provided on the front surfaces of the body portions 126 and 128 to provide space for placement of memory support arms 88' (Fig.6) and memory

devices associated therewith in the manner previously described for support arms 88 and memory device 90.

Figs. 10-13 show another embodiment of a pen 200 in accordance with the invention. The pen 200 includes a replaceable ink cartridge 202 having a handle 204 and a body portion 206. The ink cartridge 202 preferably includes  
5 several ink chambers therein, each ink chamber containing a different color ink. Preferably, the ink cartridge 202 contains three or four ink chambers.

The body portion 206 of the ink cartridge 202 is seatable within a cartridge body 208. The cartridge body has fins 42" and a plurality of  
10 printheads, as indicated by arrow 210 connected to a TAB circuit or flexible circuit 212, it being understood that the number of printheads corresponds to the number of ink chambers or colors of ink, with one printhead being provided for each ink color. A suitable outlet port and filter is likewise provided to place each ink chamber in ink flow communication with each printhead.

15 Slots 214, corresponding to the slots 68, are provided on oppositely facing inner surfaces 216 and 218 of sidewalls 220 and 222. The slots 214 receive rails 224, corresponding to rails 58 and 60, located on opposite sides 226 and 228 of the body portion 206.

A latch member 230 is preferably located on an upper portion of the  
20 body portion 206 for cooperating with an aperture 232. Aperture 232 extends through an extension 234 projecting upwardly from an uppermost portion of a front sidewall 236 of the cartridge body 208. The latch member 230 includes a yieldably biased leg portion 238 that extends upwardly from upper surface 240

of the ink cartridge. A ledge 242 located at the uppermost end of the leg portion 238 is configured to engage the aperture 232. A contact surface 244 extends upwardly from the leg portion 238 adjacent the ledge 242 for being manipulated by a user to urge the ledge 242 away from the aperture 232.

5 Figs. 14-18 depict yet another embodiment of the ink jet pen according to the invention. With reference to Figs, 14 and 15, the ink cartridges 300, 302, 304, and 306 have body portions containing front panels 308, 310, 312 and 314 and top panels 316, 318, 320 and 322 containing handles 324, 326, 328 and 330. Each of the front panels 308, 310, 312 and 314 contains a pair of memory  
10 support arms 309, 311, 313 and 315 for attachment thereto of memory modules 317, 319, 321 and 323 and latch members or fingers 332, 334, 336 and 338 for engaging latch portions on the cartridge body as described in more detail below.

The rear panels 340, 342 and 344 of the body portions of ink cartridges  
15 300, 302 and 304 preferably contains keys 346, 348 and 350 which are associated with the color ink in the cartridges for correctly positioning the cartridges in an ink jet pen. Ink cartridge 306 is preferably a black ink cartridge having a larger reservoir than the reservoirs associated with the cartridges for cyan, magenta and yellow. Accordingly, there is no need to key  
20 cartridge 306 to a particular position since it only fits in one position in the ink jet pen. However, if desired, ink cartridge 306 may also be keyed to a position in the ink jet pen.

The keys 346, 348 and 350 preferably contain one or more elongate substantially rigid projections 352, 354 and 356 which extend outwardly from panels 340, 342 and 344 respectively. The horizontal position, vertical position and/or width of the projections 352, 354 and 356 may be varied to mate with elongate slots 358, 360 and 362 in a rear panel 364 of the cartridge body 366. The length, width and/or position of the slots 358, 360 and 362 preferably vary for each color cartridge to assure that the projections 352, 354 and 356 cooperatively engage the slots when the cartridge is correctly positioned and inserted in the cartridge body 366.

During insertion and attachment of the ink cartridges 300, 302, 304 and/or 306 into the cartridge body 366, the cartridges 300, 302, 304 and/or 306 are initially inserted into the cartridge body 366 in a substantially vertical or linear direction as defined above, as opposed to initially orienting the cartridges at an angle of greater than about 10 degrees with respect to the cartridge body.

Accordingly, the projections 352, 354 and 356 are also linearly guided by elongate slots 358, 360 and 362 on the cartridge body 366 as the cartridges are initially inserted therein.

Turning now to Figs. 17 and 18, the latching mechanism for securing the ink cartridges 300, 302, 304 and 306 to the cartridge body 366 for feeding ink to printheads 368, 370, 372 and 374 will now be described. As described above, each of the front panels 308, 310, 312 and 314 of the cartridges 300, 302, 304 and 306 contain a latch member or finger 332, 334, 336 or 338 which engages a corresponding latch portion 376, 378, 380 or 382 of the body portion

366. The front panels also contain of memory support arms 309, 311, 313 and 315 (Fig. 14) holding memory modules 317, 319, 321 and 323. As the cartridges 300, 302, 304 and 306 are vertically positioned and inserted onto the cartridge body 366, the memory modules and support arms and fingers slide  
5 into position in slots 377, 379, 381 and 383 on the front panel 385 of the cartridge body 366 so that the memory modules are exposed for electrical connection to the printer. The latch portion 376, 378, 380 and 382 of the cartridge body 366 may be a shelf or shoulder for engaging the latch members 332, 334, 336 and 338 of the cartridges. It is preferred that the latch members  
10 be substantially rigid fingers, however, resiliently biased fingers may also be used. An additional advantage of the support arms for the memory modules is that it may help guide the cartridges 300, 302, 304 and 306 onto the cartridge body 366 as the fingers and latch portions are engaged.

In order to securely engage the fingers 332, 334, 336 and 338 with the  
15 latch portions 376, 378, 380 and 382, it is preferred to bias the ink cartridges 300, 302, 304 and 306 so that there is a frictional engagement between the fingers and latch portions. The ink cartridges may be biased as by biasing members or springs 384, 386, 388 and 390 which may be attached to either the cartridge body or to the ink cartridges. The biasing members may be made of a  
20 variety of materials and have a variety of shapes including, but not limited to, coil springs, resilient foam bodies, leaf springs, and the like. It is particularly preferred to locate the biasing members 384, 386, 388 and 390 toward an end of the cartridge or cartridge body opposite the latch portions 376, 378, 380 and

382. In order to engage the latch members with the latch portions, pressure is exerted on portion 400, 402, 404 and 406 of handles 324, 326, 328 and 330 as the cartridges are inserted into the cartridge body. In order to release the latch members from the latch portions, pressure is exerted on portions 408, 410, 412 and 414 of handles 324, 326, 328 and 330, thereby depressing biasing members 384, 386, 388 and 390 an amount which is effective to release fingers 332, 334, 336 and 338 from latch portions 376, 378, 380 and 382.

In Fig. 18, the biasing members 384, 386, 388 and 390 are shown attached to cylindrical projections 387, 389, 391 and 393 which are formed as part of or attached to a lower portion 395 of the cartridge body 366. The location of the biasing members 384, 386, 388 and 390 is not critical to the invention and as such may the biasing members may be located on an upper side portion or the rear panel 364 of the cartridge body 366 or in corresponding locations on the ink cartridges themselves.

The cartridge body 366 preferably contains parallel stiffener ribs 420 which are disposed between each cartridge and assist in guiding the ink cartridges onto the cartridge body. Transverse stiffener rib 422 perpendicular to ribs 420 may also be used to maintain a cartridge body width sufficient to easily insert cartridges therein. Stiffener ribs 420 and 422 are preferably included on an stiffener insert 424 which may be inserted into the cartridge body 366 during manufacture thereof. It is particularly preferred to include the biasing members 384, 386, 388 and 390 on the insert 424 as well as boss location guides 426 for guiding the ink outlet boss 428 on the ink cartridge in

connecting relationship with ink needle valve assembly 430 on insert 424. The ink needle valve assembly includes a valve slide member 432 containing a valve and a slide member guide 434 for slidably guiding the slide member 432 during the cartridge insertion step.

5 Pens in accordance with the invention advantageously facilitate replacement of depleted ink cartridges and aid in avoiding problems commonly encountered when replacing ink cartridges. For example, the rails and slots provided on the ink cartridge and cartridge body cooperate to guide the depleted ink cartridge directly away from the cartridge body so as to avoid  
10 bending or skewing of the sealing member and other components of the pen. Likewise, when installing a fresh ink cartridge, the rails and slots cooperate to guide the ink cartridge in substantially linear line of travel onto the cartridge body. This likewise avoids stresses on the components such as bending and the like which can degrade or damage the components and cause liquid or gas  
15 leakage. Avoiding misalignment of the port that conducts ink from the cartridge also helps to avoid introducing air into the ink cartridge during seating of the cartridge, and/or prevents damage to the seal components of the cartridge body.

In each of the embodiments described above, the ink cartridges contain  
20 an initial supply of ink and are adapted to be replaceable once the ink supply in the cartridges is depleted. In another alternative embodiment, ink may be resupplied to one or more cartridges by a variety of means. For example, with reference to Fig. 19, the cap or cover 440 of the ink cartridge 442 may be

removable rather than fixedly attached to the cartridge side wall portions 444, 446, 448 and 450 around the upper periphery 452 of the cartridge 442 so that the cartridge may be refilled with ink. In order to assist in removing and replacing the caps or covers 440, the caps or covers may include an adapter 454  
5 containing one or more apertures 456 for engagement with one or more posts or projections 458 pending from the underside 460 of cover 440. In this embodiment, the adapter 454 is fixedly attached to the upper periphery 452 as by welding or adhesives and the cover 440 is removable attached to the adapter 454. Upon removal of the cover, ink may be inserted into the cartridge 442  
10 through one or more apertures 456 or ink fill aperture 462.

In yet another alternative, the cover 440 may be replaced by a cover 464 (Fig. 20) containing an ink inlet port 466 which may be attached to a supply conduit 468 for continuous or periodic refilling of the ink cartridge 442 with ink from an ink reservoir. In this embodiment, the cover 464 may be fixedly  
15 attached directly to the upper periphery 452 of the ink cartridge 442 (Fig. 19) without the need for adapter 454. The remote ink reservoir may be contained within the printer itself or in an ink container separate from and attached by means of an ink feed conduit to the printer. It is preferred, however, that the remote ink reservoir not be attached to the movable carriage for moving the  
20 cartridge body and ink cartridge during a printing operation.

The foregoing description of certain embodiments of the invention has been provided for the purposes of illustration only, and it is understood that



various modifications or alterations may be made without departing from the spirit and scope of the invention as set forth in the following claims.

21  
22  
23  
24  
25  
26  
27

## CLAIMS

THE CLAIMS DEFINING THE INVENTION ARE AS FOLLOWS:

1. An ink jet pen comprising a cartridge body having a printhead  
and a replaceable ink cartridge, said ink cartridge and  
cartridge body containing at least one cooperating elongate  
recess having axis parallel to the length of the recess, at least  
5 one projection located on mutually facing surfaces thereof,  
wherein the at least one projection and the at least one recess  
are engageable with one another for guidably positioning the  
ink cartridge to a desired position relative to the cartridge  
body along an guiding axis which is at least substantially  
10 parallel with the recess axis, and a latch member connected to  
the ink cartridge for engaging a portion of the cartridge body  
for maintaining the ink cartridge in the desired position  
relative to the cartridge body.
2. The ink jet pen of Claim 1 further comprising an urging  
15 member for urging said latch member in latching engagement  
with said portion of said cartridge body.
3. The ink pen of Claim 1 wherein said at least one recess  
20 comprises an elongate slot, said slot extending from a first  
portion of the ink cartridge toward a second portion of the ink  
cartridge and said at least one projection comprises a raised  
elongate projection, said projection extending from a second

portion of the cartridge body toward a first portion of the cartridge body.

4. The ink pen of Claim 4 wherein said elongate slot has a variable width, with the width adjacent the first portion of the ink cartridge being greater than the width adjacent the second portion of the ink cartridge, and said elongate projection has a variable width, with the width adjacent the second portion of the cartridge body being greater than the width adjacent the first portion of the cartridge body.

5. The ink pen of Claim 1 wherein said at least one recess comprises an elongate slot, said slot extending from a second portion of the cartridge body toward an first portion of the cartridge body and said at least one projection comprises a raised elongate projection, said projection extending from a first portion of the ink cartridge toward an second portion of the ink cartridge.

6. The ink pen of Claim 6 wherein said elongate slot has a variable width, with the width adjacent the second portion of the cartridge body being greater than the width adjacent the first portion of the cartridge body, and said elongate projection has a variable width, with the width adjacent the

first portion of the ink cartridge being greater than the width adjacent the second portion of the ink cartridge.

7. The ink pen of Claim 1 containing at least two cooperating recesses and at least two projections located on mutually facing surfaces of the cartridge and cartridge body.
8. The ink pen of Claim 1 further comprising a cartridge having a removable cover for refilling the cartridge with ink.
9. The ink pen of Claim 1 further comprising a cover containing an ink refilling port.
10. A method of replacing an ink cartridge on an ink jet pen, the method comprising the steps of providing a cartridge body having a printhead and a replaceable ink cartridge, the printhead and the ink cartridge having at least one cooperating elongate recess having axis parallel to the length of the recess and at least one projection engageable with the elongate recess and a latch member connected to the ink cartridge for engaging a portion of the cartridge body for maintaining the ink cartridge in the desired position relative to the cartridge body, moving the ink cartridge with respect to the cartridge body in a direction which is, at least substantially, parallel to the recess axis in order to engage the recess and the projection and seat the ink cartridge on the cartridge body so that ink

5

10

15

20

within the ink cartridge is in flow communication with the printhead and engaging the latch member with a portion of the cartridge body in order to maintain the ink cartridge in the desired position relative to the cartridge body.

5

11. The method of Claim 10 wherein the cartridge body includes an urging member for urging said latch member in latching engagement with said portion of said cartridge body.

10

12. The method of Claim 10 wherein said at least one recess comprises an elongate slot, said slot extending from a first portion of the ink cartridge toward a second portion of the ink cartridge and said at least one projection comprises a raised elongate projection, said projection extending from a second portion of the cartridge body toward a first portion of the cartridge body.

15

13. The method of Claim 12 wherein said elongate slot has a variable width, with the width adjacent the first portion of the ink cartridge being greater than the width adjacent the second portion of the ink cartridge, and said elongate projection has a variable width, with the width adjacent the second portion of the cartridge body being greater than the width adjacent the first portion of the cartridge body.

20

14. The method of Claim 10 wherein said at least one recess comprises an elongate slot, said slot extending from a second portion of the cartridge body toward an first portion of the cartridge body and said at least one projection comprises a raised elongate projection, said projection extending from a first portion of the ink cartridge toward an second portion of the ink cartridge.

5

15. The method of Claim 14 wherein said elongate slot has a variable width, with the width adjacent the second portion of the cartridge body being greater than the width adjacent the first portion of the cartridge body, and said elongate projection has a variable width, with the width adjacent the first portion of the ink cartridge being greater than the width adjacent the second portion of the ink cartridge.

10

16. The method of Claim 10 wherein the ink cartridge includes a removable cover, further comprising removing the cover from the ink cartridge and refilling the cartridge with ink.

15

17. The method of Claim 10 wherein the ink cartridge includes a cover having an ink fill port, further comprising refilling the ink cartridge with ink by feeding ink thereto through the ink fill port.

20

18. A replaceable ink cartridge for use with an ink jet pen of the type having a semi-permanent or permanent cartridge body containing a printhead and positionable on the cartridge body, the replaceable ink cartridge comprising:

5 a body portion defining a reservoir and containing an initial supply of ink within the reservoir;

a handle defined on an upper portion of the body portion;

10 a latch mechanism defined on a side portion of the body portion for engaging a latching portion of the cartridge body;

15 an outlet port defined on the body portion and in flow communication with the reservoir, the port being placeable in flow communication with the printhead when the ink cartridge is installed on the cartridge body; and

an elongate structure substantially aligned with a substantially vertical length axis of the ink cartridge and defined on one or more exterior surfaces of the ink cartridge,

20 wherein the elongate structure of the ink cartridge is positionable during installation of the ink cartridge on a cartridge body so as to be engageable with one or more elongate portions of the cartridge body having an axis parallel to the length of the elongate portions for guidably positioning

the ink cartridge to a desired position relative to the cartridge body in a direction which is, at least initially, substantially parallel with the axis of the elongate portion.

5

19. The ink cartridge of Claim 18 wherein the elongate structure comprises at least two elongate recesses on opposing sides of the body portion.

20. The ink cartridge of Claim 18 wherein the elongate structure comprises at least two elongate projections on opposing sides of the body portion.

10

21. The ink cartridge of Claim 18 wherein the latch mechanism contains a leg portion, an outwardly biased lever portion extending upwardly from the leg portion and an outwardly extending finger located on the lever portion for engaging the latching portion on the cartridge body.

15

22. The ink cartridge of Claim 18 wherein the ink cartridge contains a biasing member disposed between the cartridge body and ink cartridge on a lower body portion of the ink cartridge opposite the handle and the latch mechanism comprises an outwardly extending, substantially rigid finger for engaging the latching portion on the cartridge body.

20

23. The ink cartridge of Claim 22 wherein the biasing member comprises a coil spring.



24. The ink cartridge of Claim 18 wherein the ink cartridge contains a cover which is removably adaptable for refilling the cartridge with ink.

5 25. The ink cartridge of Claim 18 wherein the ink cartridge contains a cover containing an ink fill port for refilling the cartridge with ink.

DATED: 2nd October, 2000

PHILLIPS ORMONDE & FITZPATRICK

Attorneys for:

LEXMARK INTERNATIONAL, INC.

*David B Fitzpatrick*

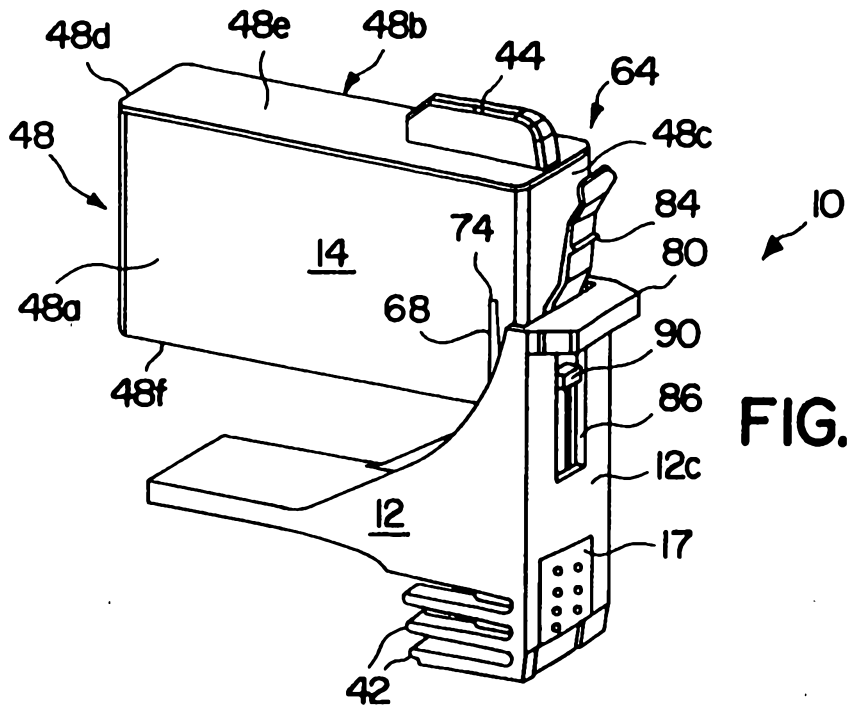

FIG. 1

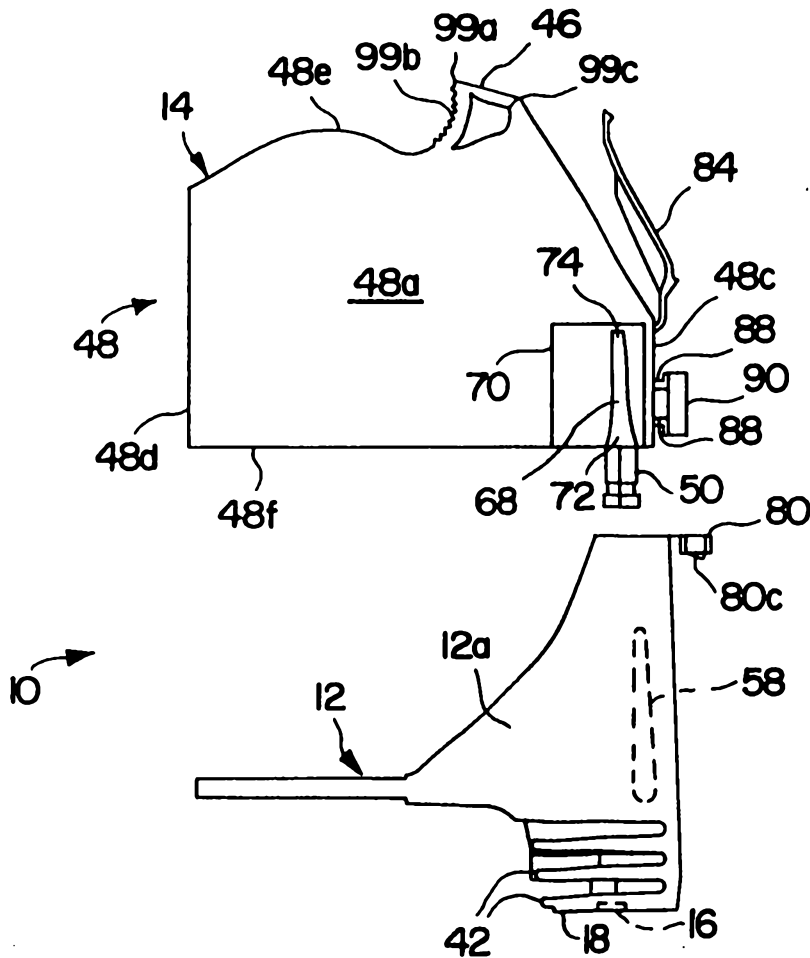
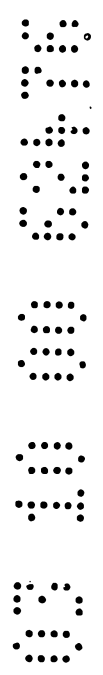

FIG. 2



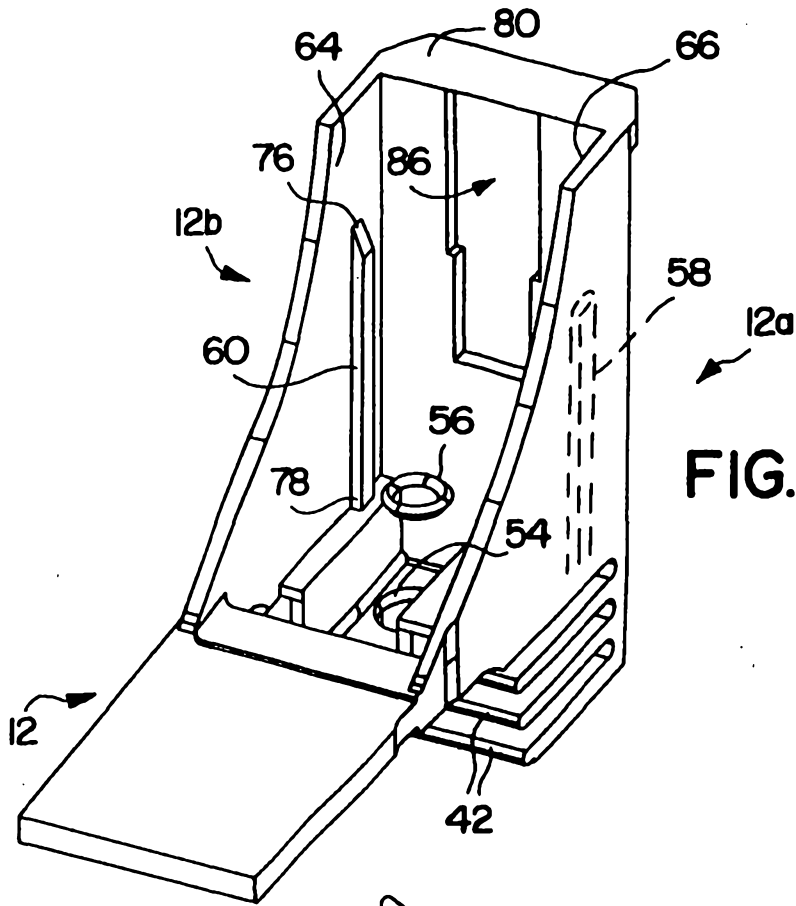

FIG. 3

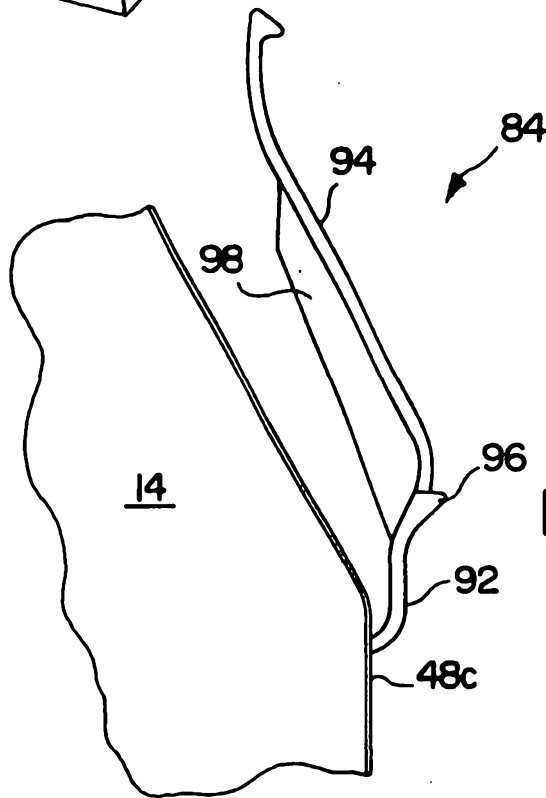
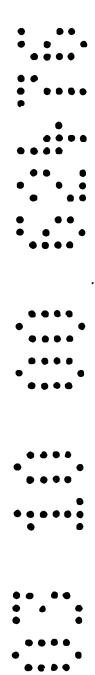

FIG. 4



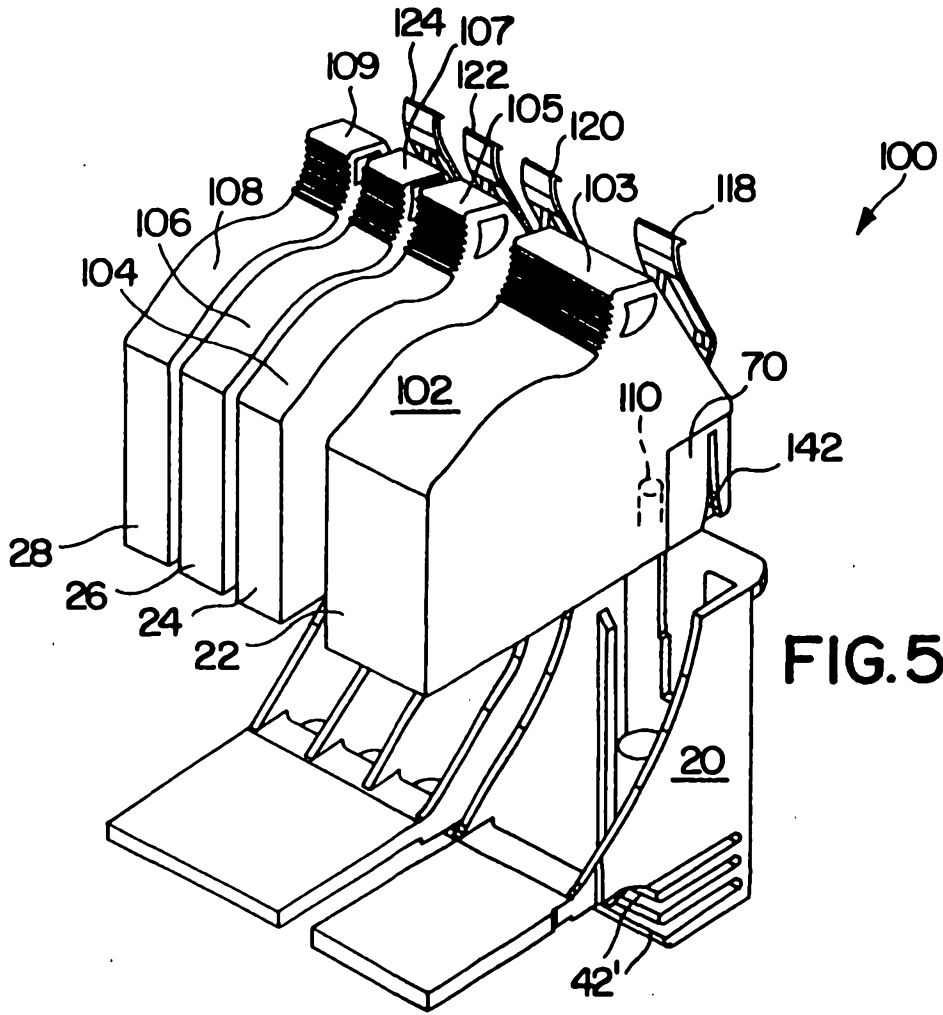

FIG. 5

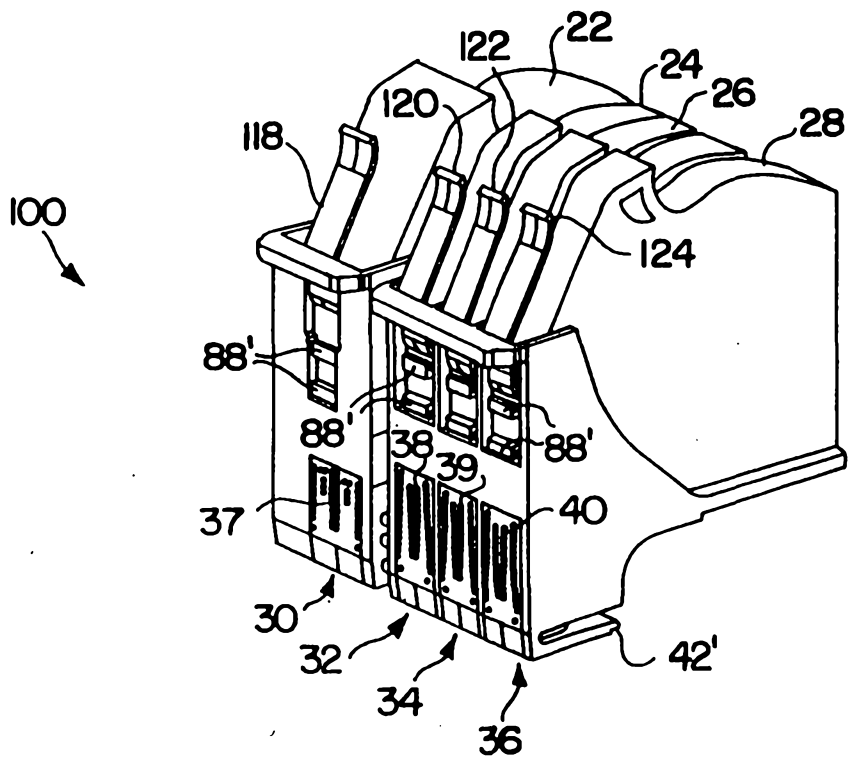
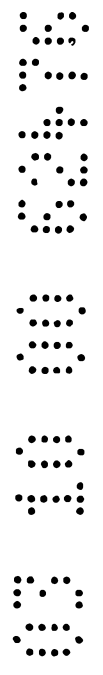

FIG. 6



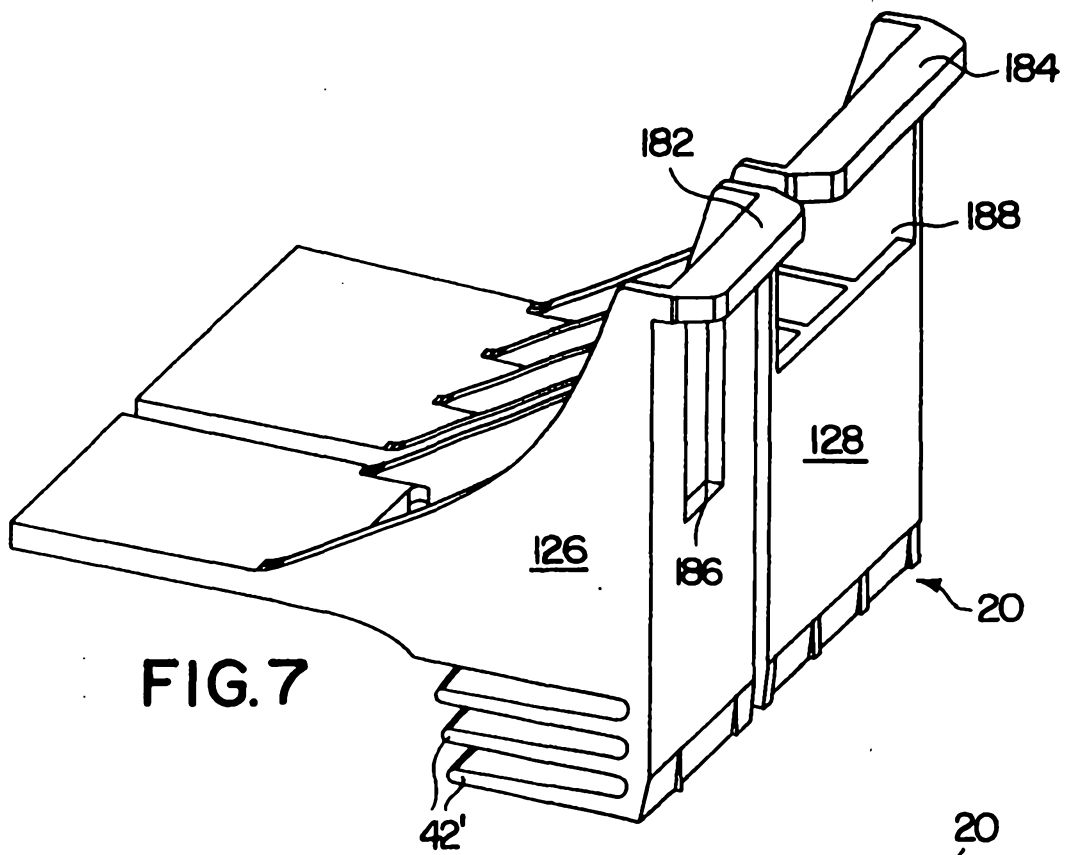

FIG. 7

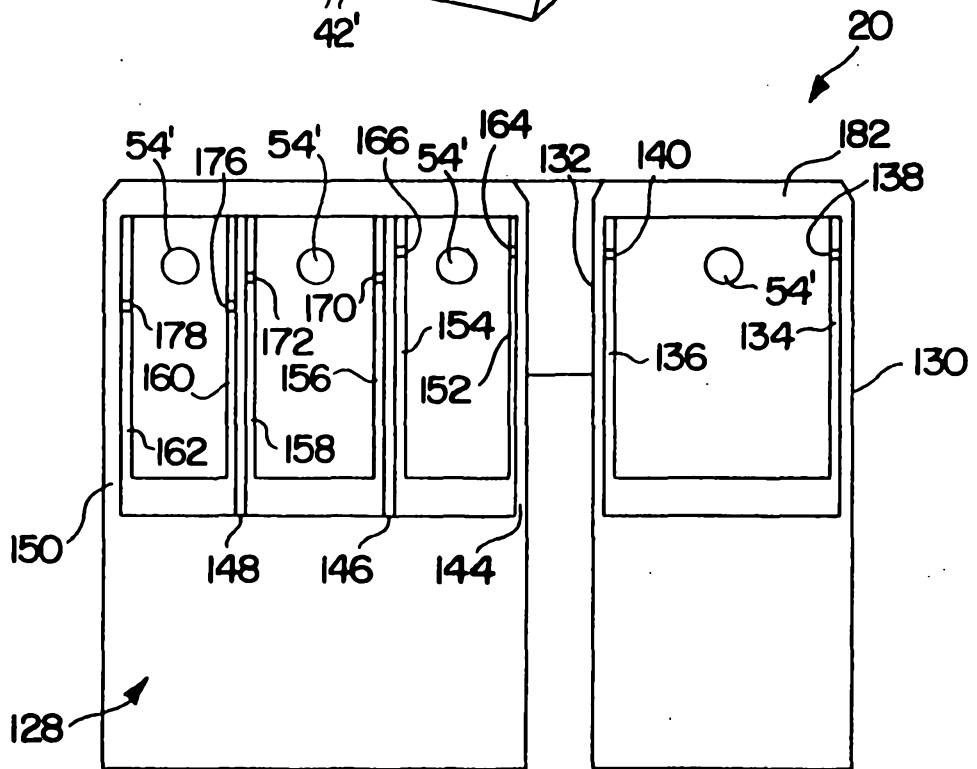
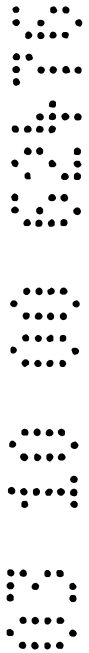

FIG. 8



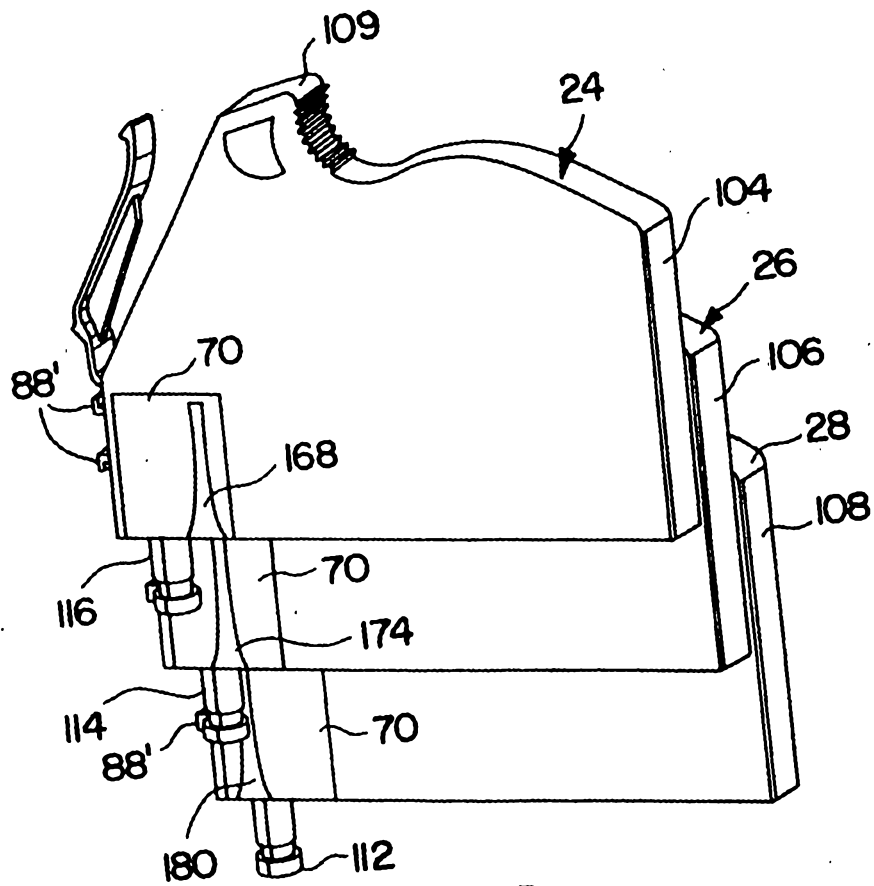

FIG.9

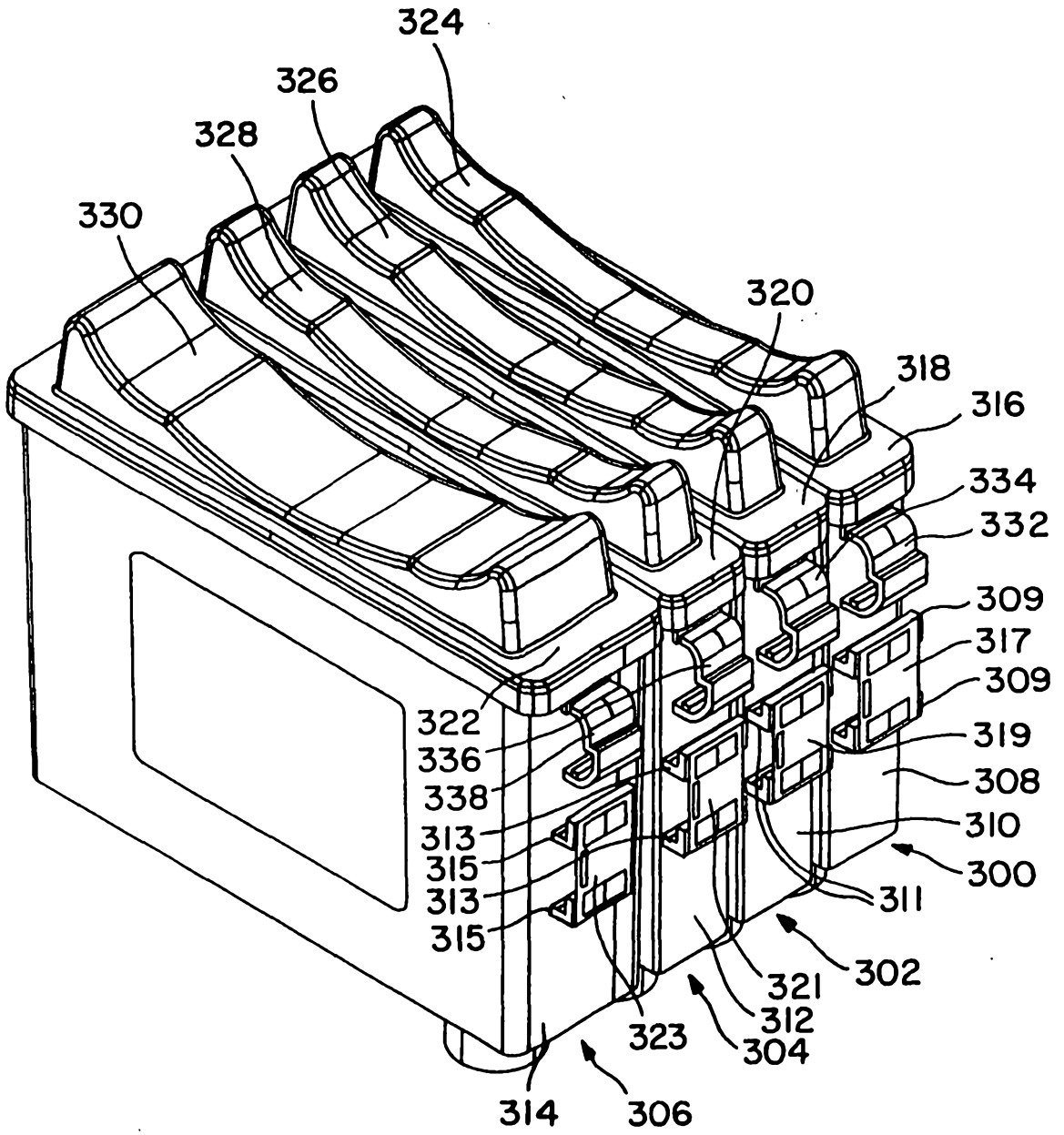

FIG. 14

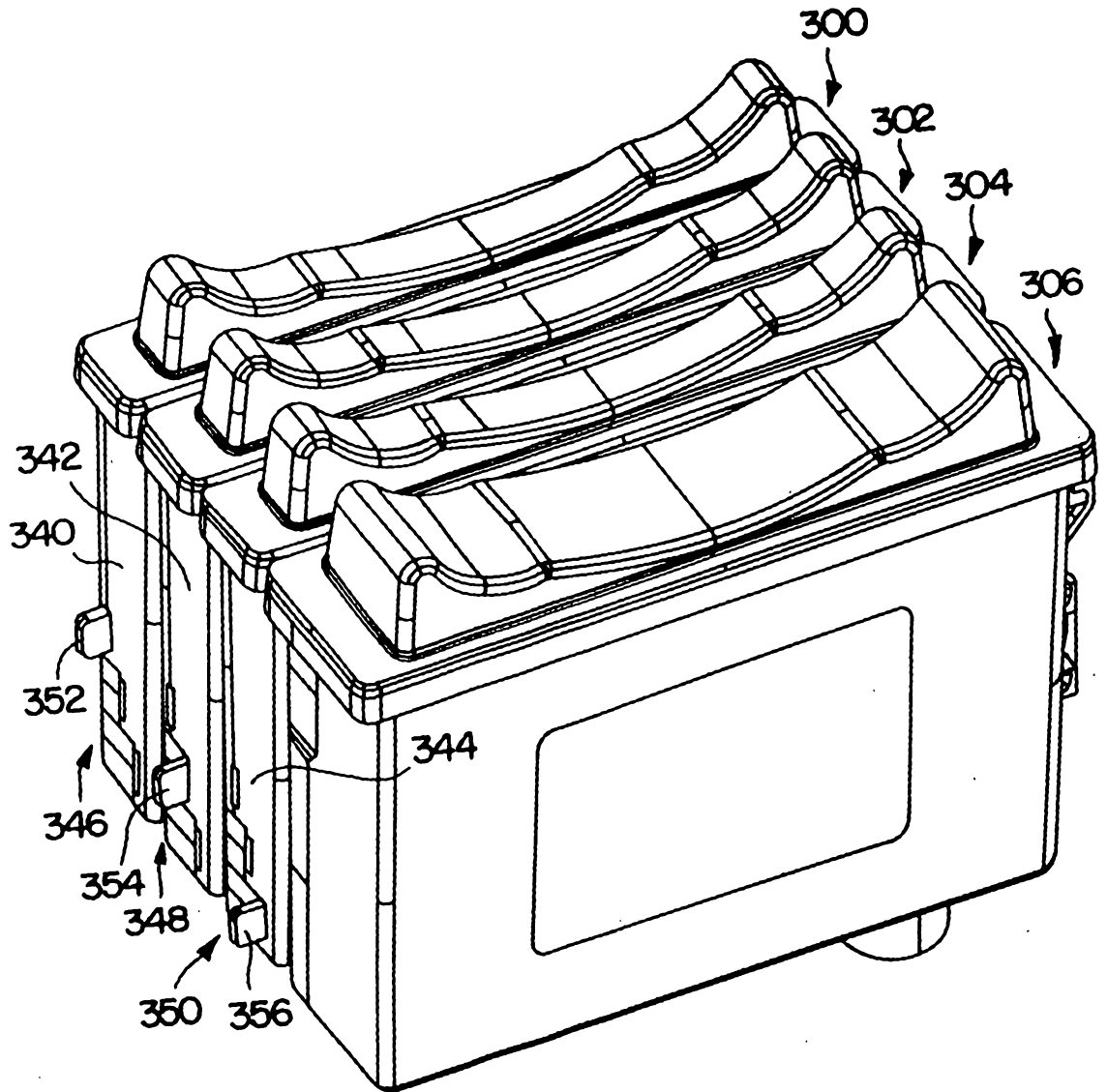

FIG. 15



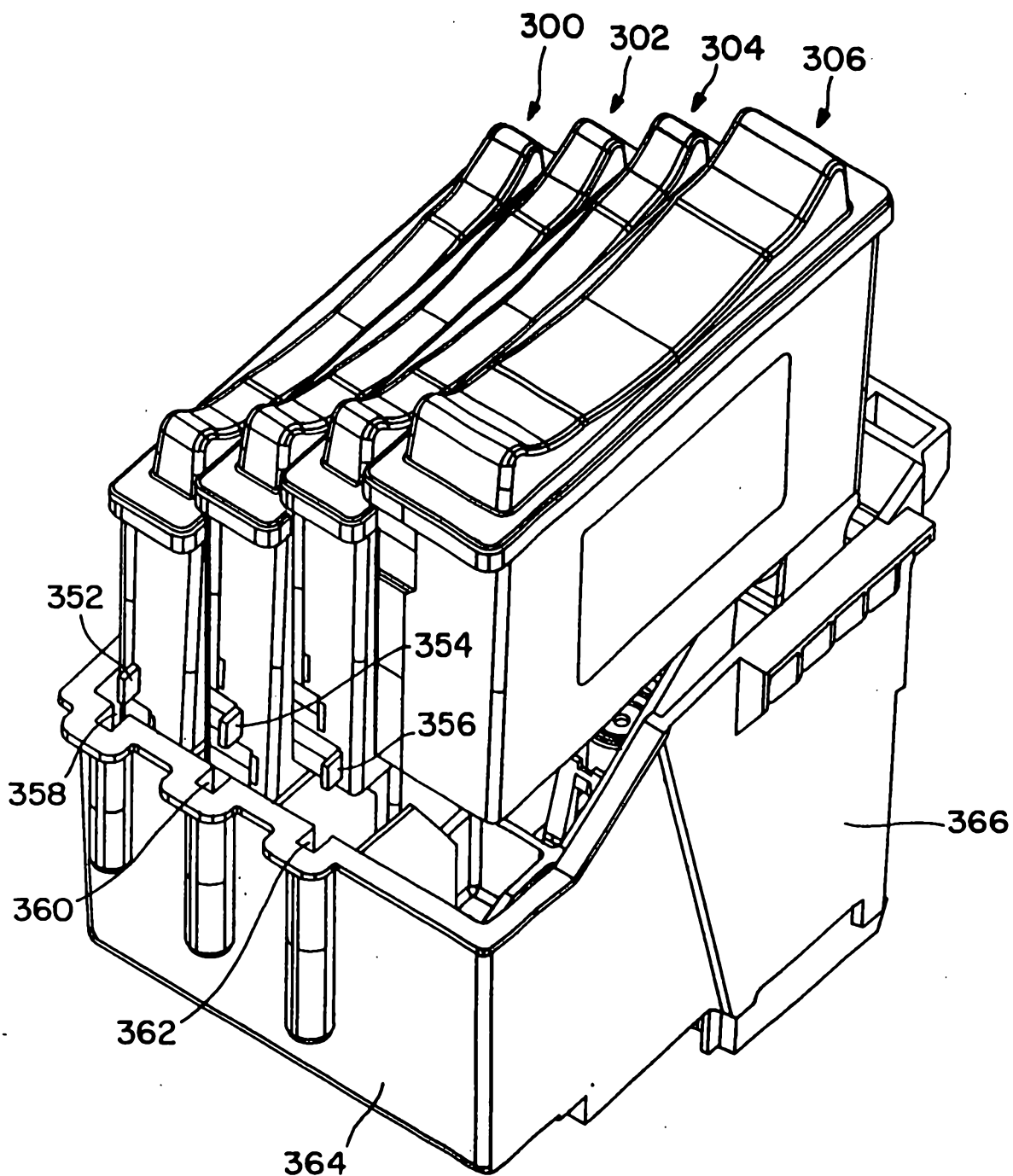

FIG. 16

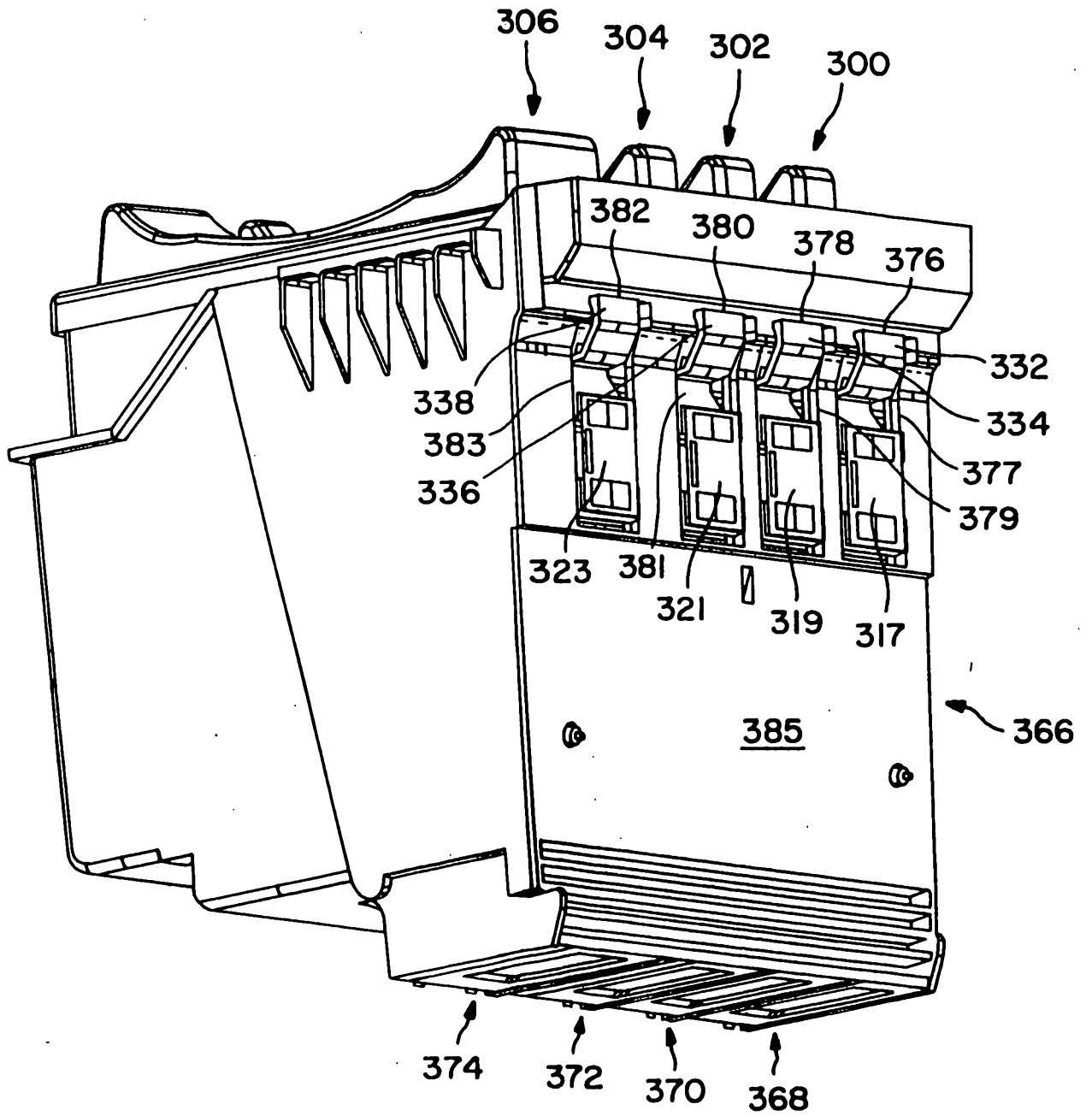

FIG. 17

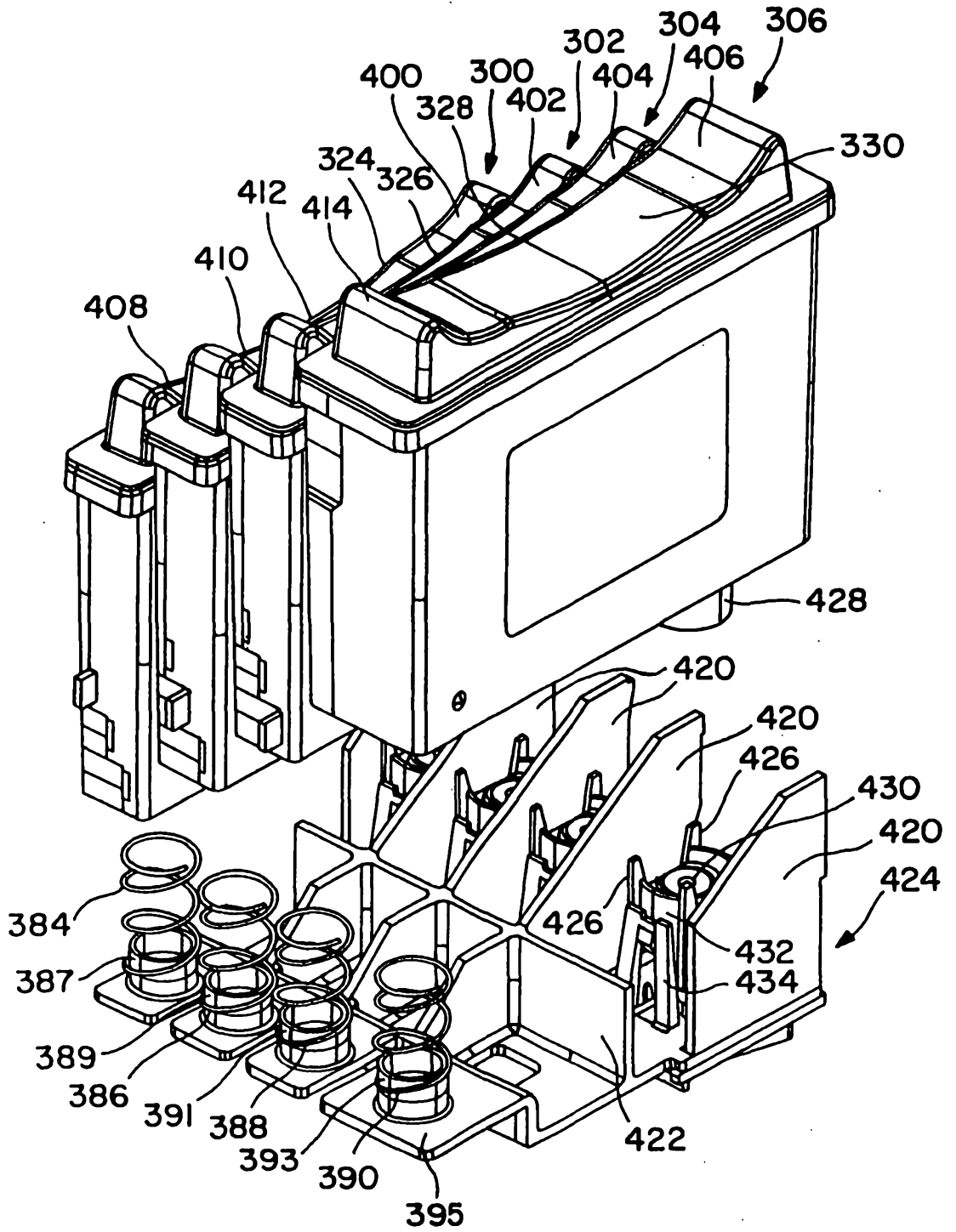

FIG. 18

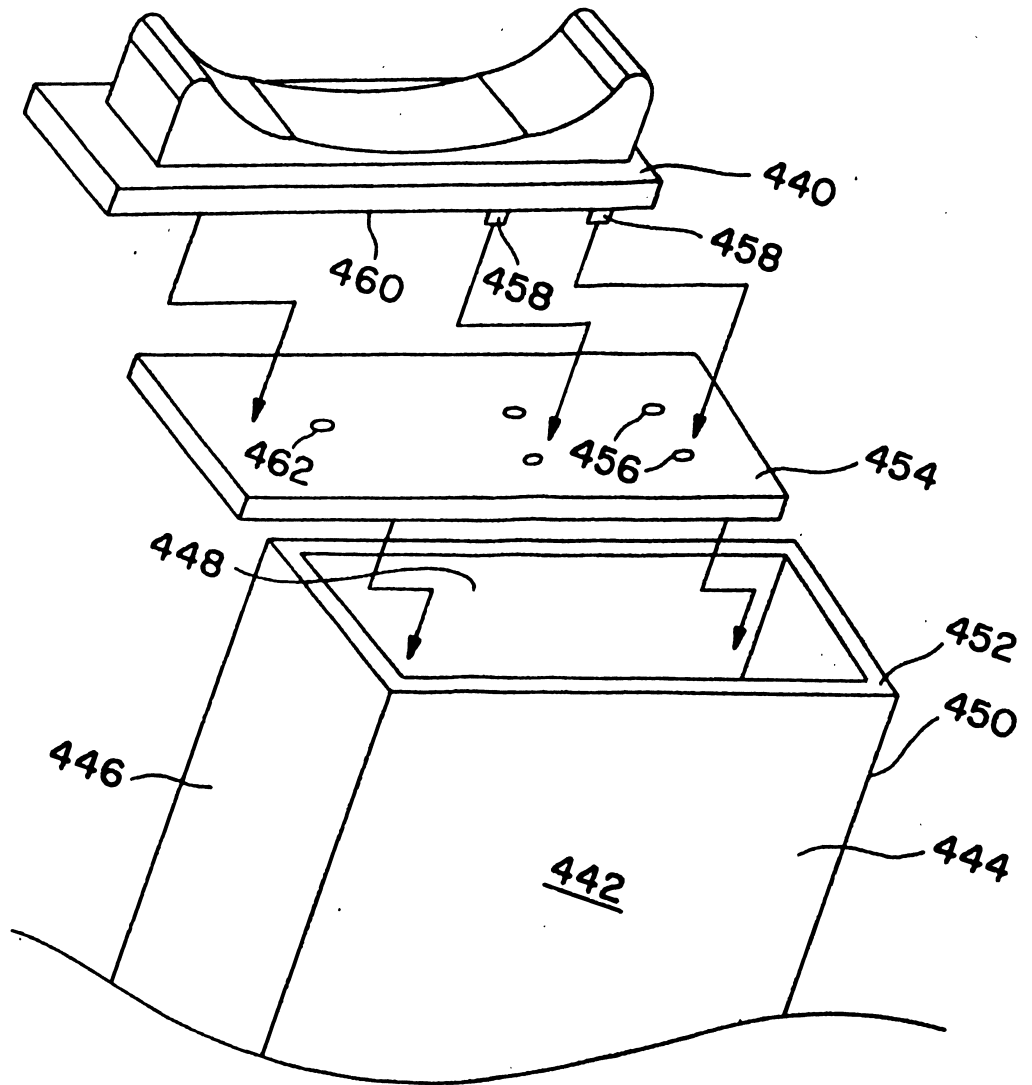

FIG. 19

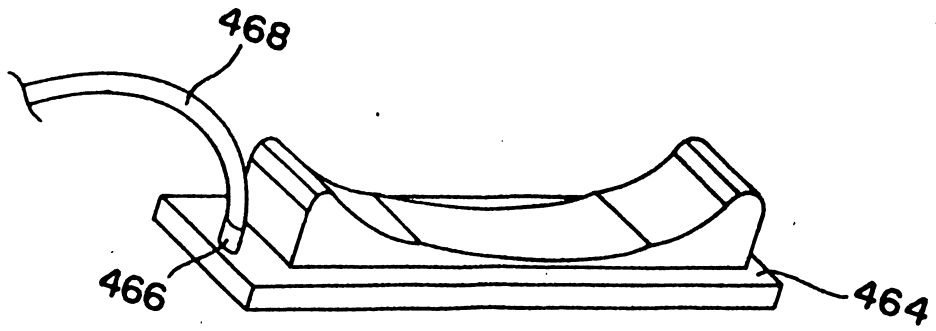

FIG. 20

Handwritten text consisting of several rows of dots, possibly representing a barcode or a specific code.