



US00D697217S

(12) **United States Design Patent**
Nasir

(10) **Patent No.:** **US D697,217 S**

(45) **Date of Patent:** **** Jan. 7, 2014**

(54) **ARM RESTRAINT FOR A PATIENT**

(71) Applicant: **Docsinnovent Limited**, London (GB)

(72) Inventor: **Muhammed Aslam Nasir**, Bedfordshire (GB)

(73) Assignee: **Docsinnovent Limited** (GB)

(**) Term: **14 Years**

(21) Appl. No.: **29/459,872**

(22) Filed: **Jul. 3, 2013**

Related U.S. Application Data

(62) Division of application No. 29/400,089, filed on Aug. 23, 2011, now Pat. No. Des. 686,737.

(30) **Foreign Application Priority Data**

Feb. 23, 2011 (EM) 001825126-0001
Feb. 23, 2011 (EM) 001825126-0002
Feb. 23, 2011 (EM) 001825126-0003

(51) **LOC (10) Cl.** **24-01**

(52) **U.S. Cl.**
USPC **D24/190**

(58) **Field of Classification Search**
USPC D24/190, 192; D29/100, 113-114,
D29/120.1-120.2; D21/662, 683, 684;
128/869, 876-881; 473/212-215, 217,
473/450, 458; 602/26, 27, 62
See application file for complete search history.

(56) **References Cited**

U.S. PATENT DOCUMENTS

1,414,012 A 4/1922 Flint
1,418,637 A 6/1922 Swift
2,468,580 A * 4/1949 Weis et al. 473/214
2,693,794 A 11/1954 Vernon

3,036,831 A * 5/1962 Engan 473/63
3,640,273 A * 2/1972 Ray 602/5
D230,894 S 3/1974 Lehneis
4,014,327 A 3/1977 Spiro
D245,429 S 8/1977 Arluck
4,239,228 A 12/1980 Norman et al.
4,254,766 A * 3/1981 Kordis 602/5
4,286,588 A * 9/1981 Lovegrove 128/877
4,414,969 A 11/1983 Heyman
4,765,279 A 8/1988 Klickstein
4,896,887 A * 1/1990 Cable 473/212
4,911,728 A 3/1990 Rigel
4,941,460 A * 7/1990 Working 602/21
4,977,890 A * 12/1990 Mann 602/21
5,007,415 A 4/1991 Marion
5,016,885 A 5/1991 Quigley
5,248,146 A * 9/1993 Viets et al. 473/206
5,263,497 A 11/1993 Grabenkort et al.
D352,572 S * 11/1994 Pustizzi, Jr. D29/120.2
5,435,563 A * 7/1995 Salvatore 473/215
5,456,650 A * 10/1995 Williams et al. 482/47

(Continued)

Primary Examiner — Susan E Krakower

(74) *Attorney, Agent, or Firm* — Belles Katz LLC

(57) **CLAIM**

The ornamental design for an arm restraint for a patient, as shown and described.

DESCRIPTION

FIG. 1 is a top, front isometric view of an arm restraint for a patient according to the new design;
FIG. 2 is a front view thereof;
FIG. 3 is a rear view thereof;
FIG. 4 is a top view thereof;
FIG. 5 is a bottom side view thereof;
FIG. 6 is a right side view thereof; and,
FIG. 7 is a left side view thereof.
The broken lines shown in the drawings illustrate a disclaimed stitching pattern that forms no part of the claimed design.

1 Claim, 7 Drawing Sheets

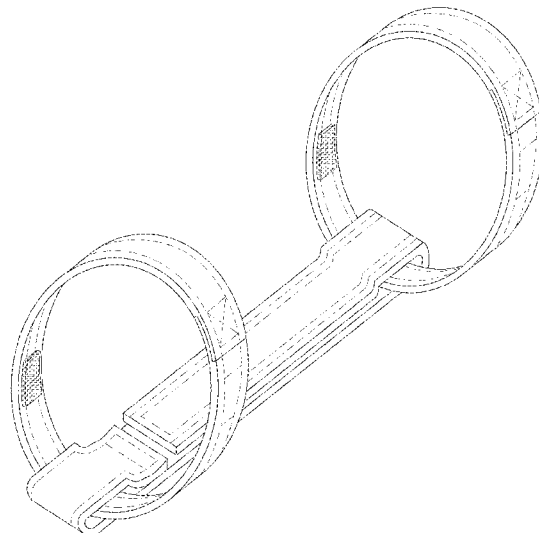

US D697,217 S

Page 2

(56)

References Cited

U.S. PATENT DOCUMENTS

6,350,206 B1 *	2/2002	Lambert, II	473/205	D664,612 S *	7/2012	Pinskiy et al.	D21/662
D629,913 S *	12/2010	Beckwith et al.	D24/192	D686,737 S *	7/2013	Nasir	D24/190
7,897,857 B2 *	3/2011	Lockwood	84/280	2007/0000500 A1 *	1/2007	Richard	128/869
					2008/0116239 A1 *	5/2008	Lu	224/575

* cited by examiner

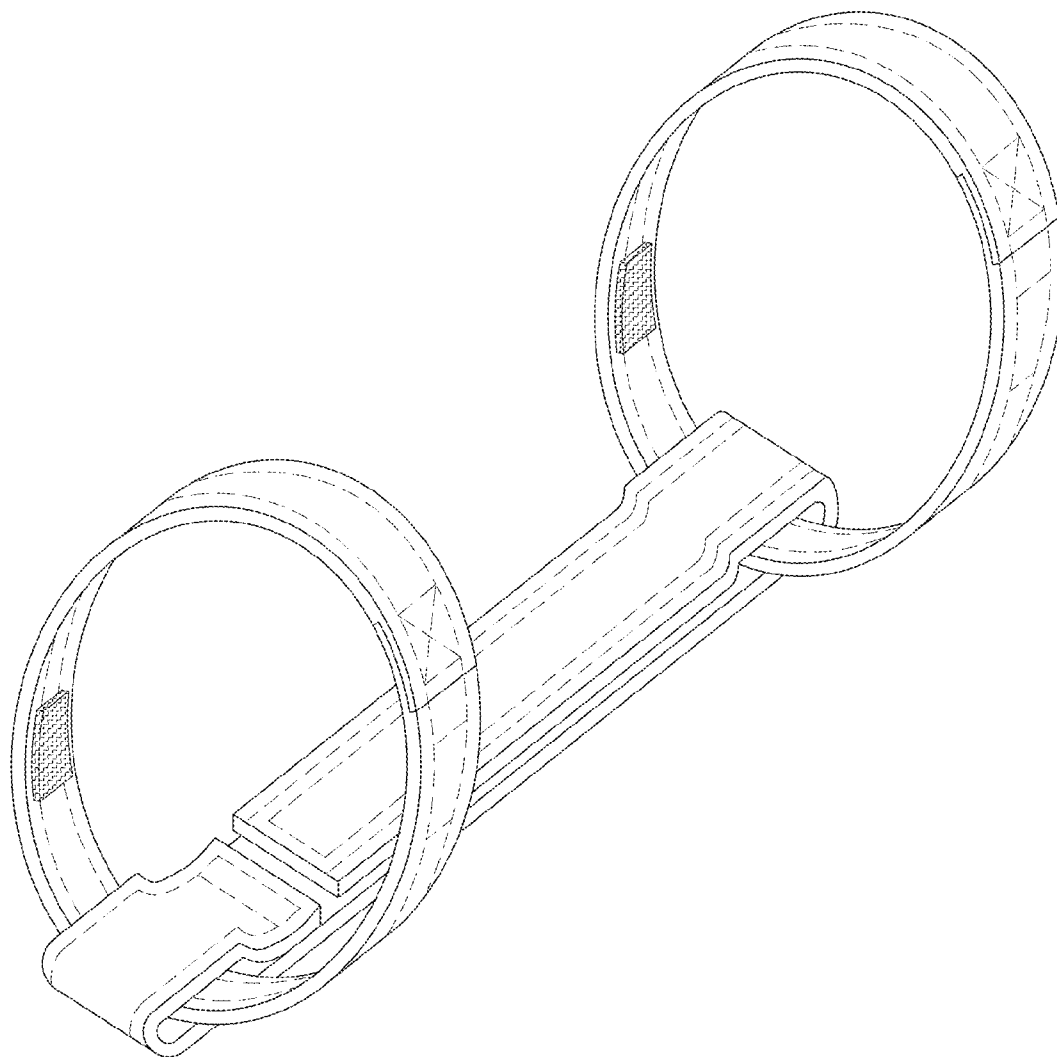

FIGURE 1

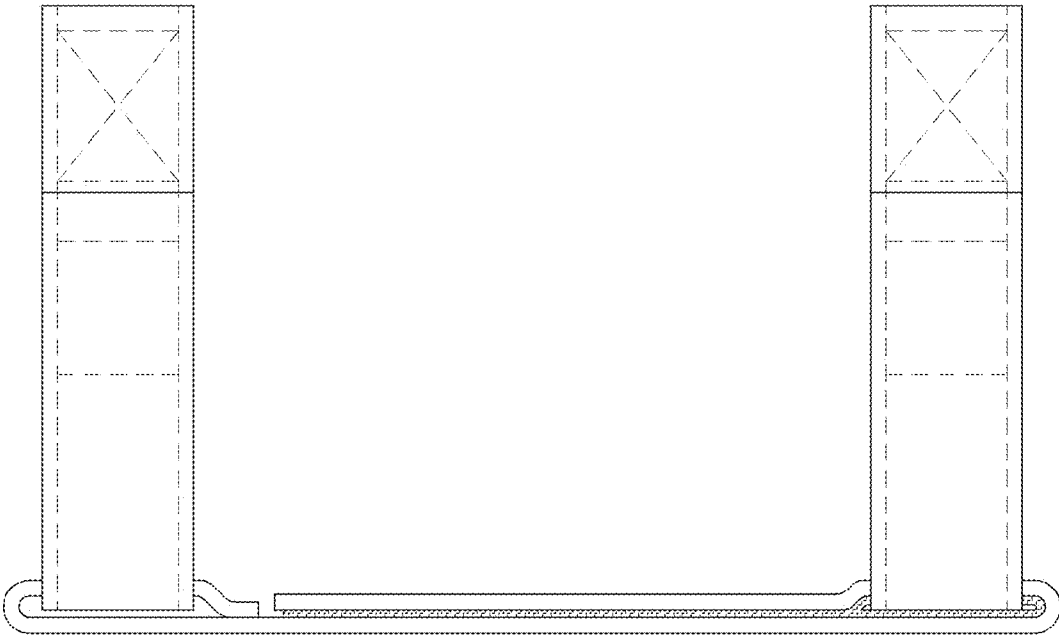

FIGURE 2

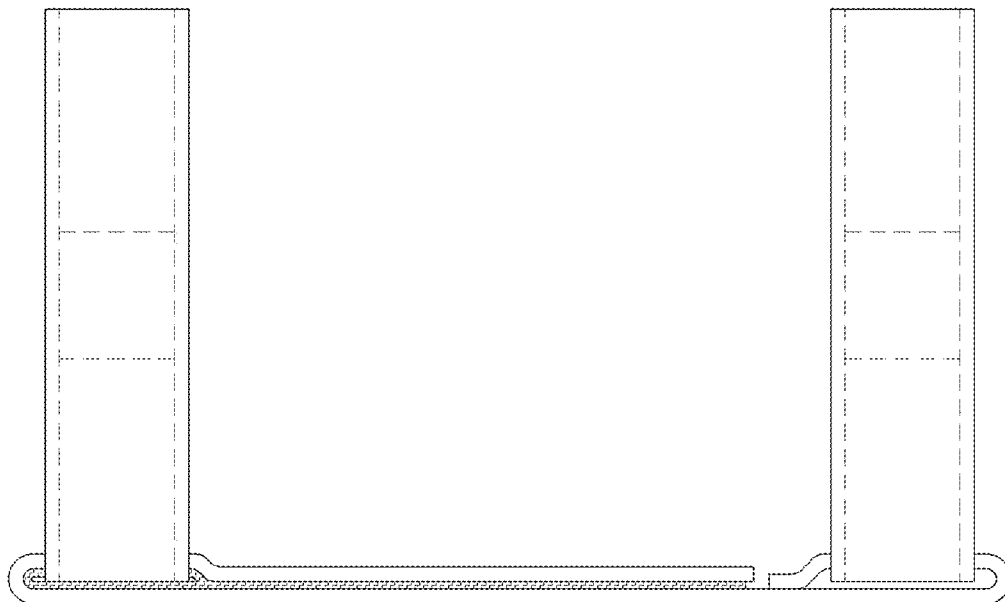

FIGURE 3

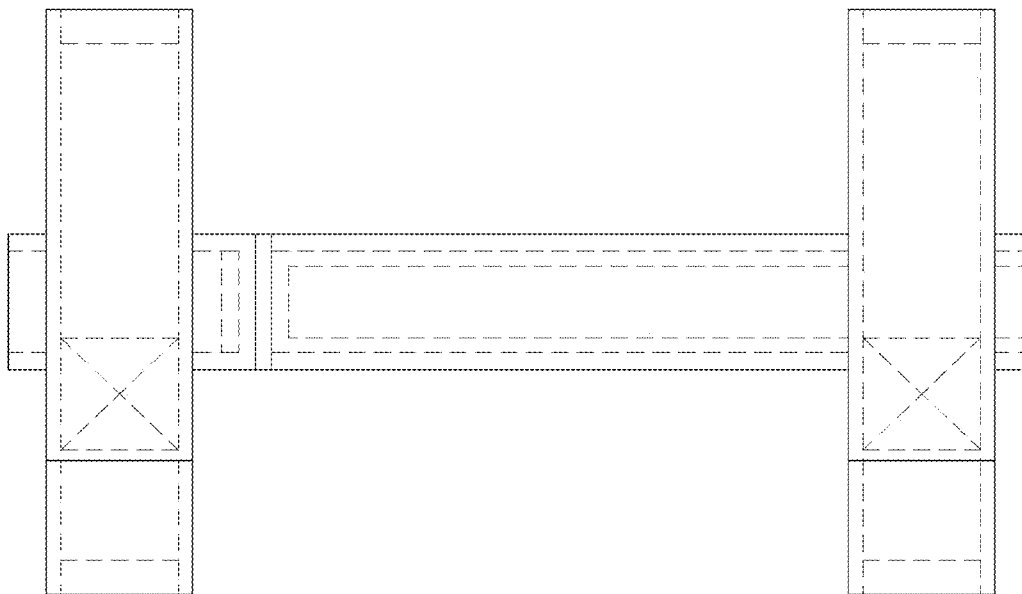

FIGURE 4

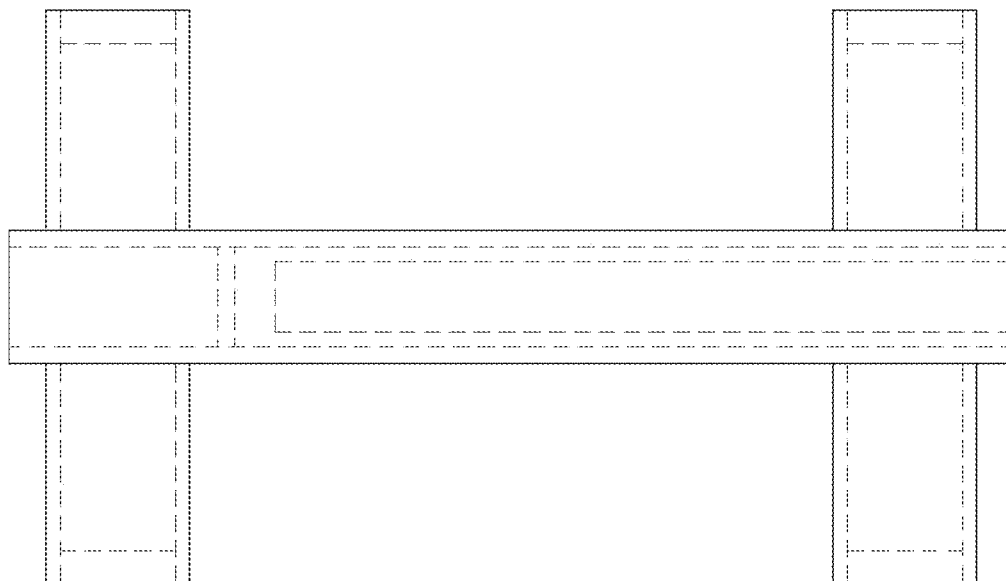

FIGURE 5

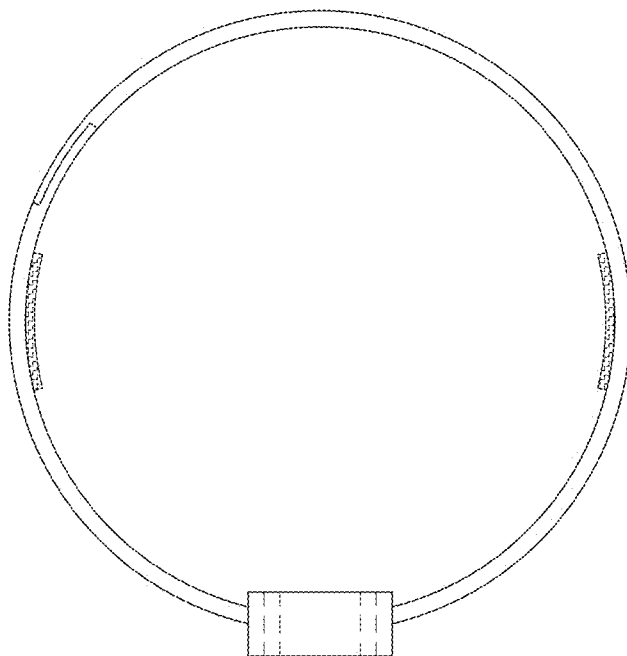

FIGURE 6

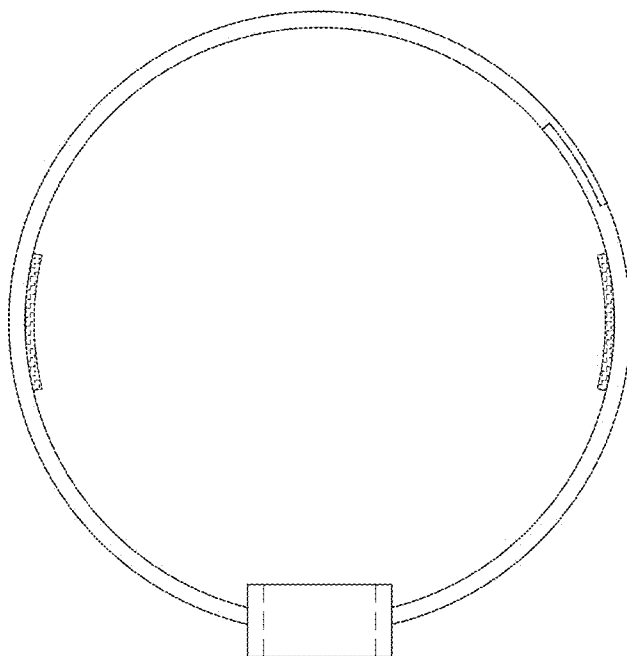

FIGURE 7