



(86) Date de dépôt PCT/PCT Filing Date: 2001/03/16
 (87) Date publication PCT/PCT Publication Date: 2002/09/26
 (45) Date de délivrance/Issue Date: 2009/08/18
 (85) Entrée phase nationale/National Entry: 2003/02/18
 (86) N° demande PCT/PCT Application No.: US 2001/008674
 (87) N° publication PCT/PCT Publication No.: 2002/075428

(51) Cl.Int./Int.Cl. *G02B 26/02* (2006.01),
G02B 6/24 (2006.01), *G02B 6/35* (2006.01),
H01H 1/00 (2006.01)

(72) Inventeurs/Inventors:
 HICHWA, BRYANT, US;
 MARXER, CORNEL, CH;
 GALE, MICHAEL, CH

(73) Propriétaire/Owner:
 JDS UNIPHASE CORPORATION, US

(74) Agent: TEITELBAUM & MACLEAN

(54) Titre : MICROCOMMUTATEUR BISTABLE
 (54) Title: BI-STABLE MICRO SWITCH

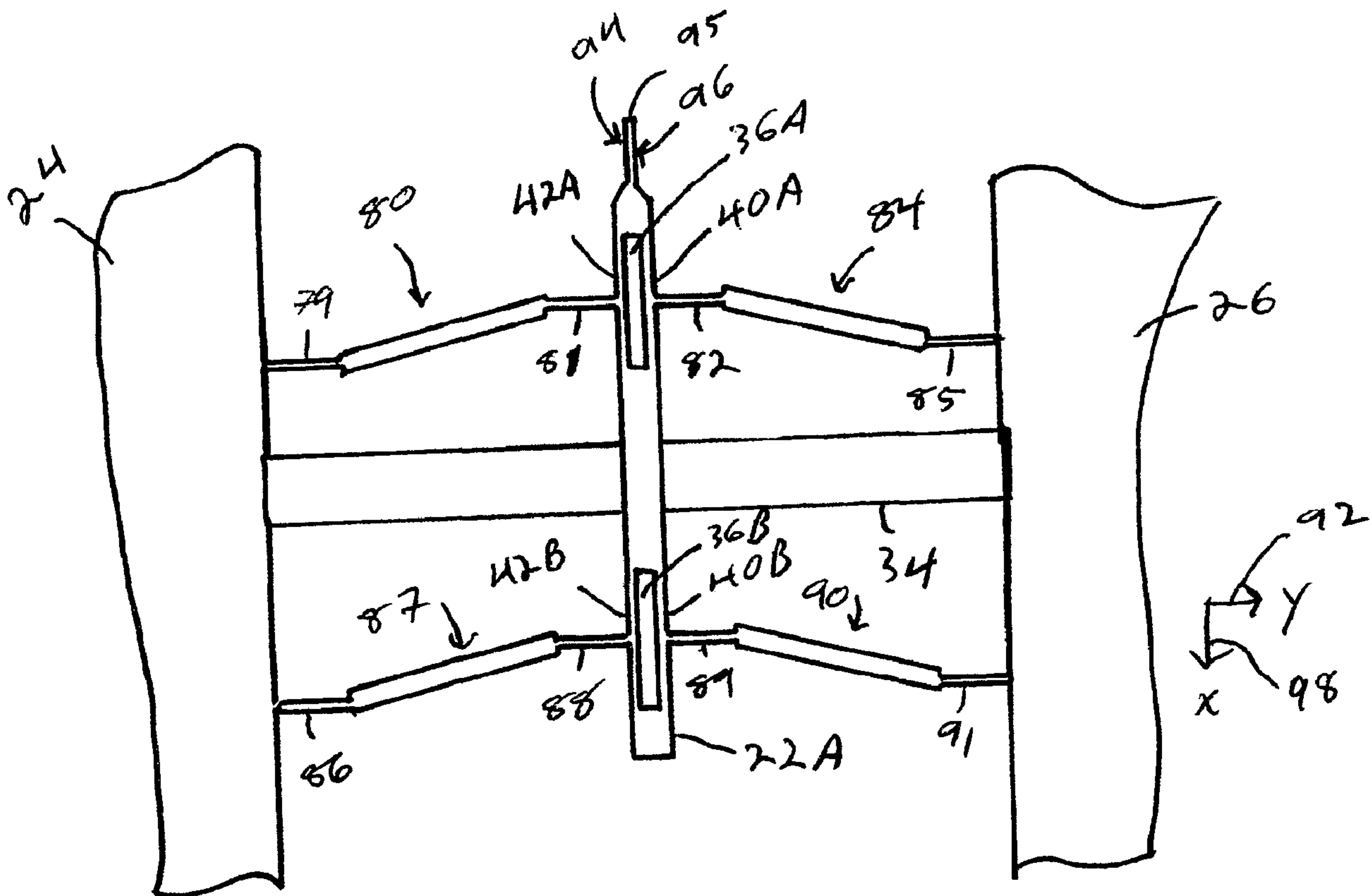

(57) Abrégé/Abstract:

A bi-stable micro-machined electro-mechanical system ("MEMS") switch. In a preferred embodiment, the bi-stable MEMS switch is used in an NXN optical signal switching system. Spring arms act in conjunction with a hollow beam portion of a movable center body of the switch to accommodate strain in the arms as the switch is moved from a first position to a second position, thus

(57) **Abrégé(suite)/Abstract(continued):**

avoiding buckling of the spring arms. Both the first and second switch position occur at local minimums of mechanical potential energy, thus providing two stable switch states. The center body is moved in relation to static portions of the switch by an actuator, such as an electro-static comb drive.

(12) INTERNATIONAL APPLICATION PUBLISHED UNDER THE PATENT COOPERATION TREATY (PCT)

(19) World Intellectual Property Organization
International Bureau(43) International Publication Date
26 September 2002 (26.09.2002)

PCT

(10) International Publication Number
WO 02/075428 A1

- (51) International Patent Classification⁷: G02B 26/02, CH-2007 Neuchatel (CH). GALE, Michael; Badnerstrasse 6/24, H01H 1/00 569, CH-8048 Zurich (CH).
- (21) International Application Number: PCT/US01/08674 (74) Agent: HEWETT, Scott; No. 223, 400 West Third Street, Santa Rosa, CA 95401 (US).
- (22) International Filing Date: 16 March 2001 (16.03.2001) (81) Designated State (national): CA.
- (25) Filing Language: English (84) Designated States (regional): European patent (AT, BE, CH, CY, DE, DK, ES, FI, FR, GB, GR, IE, IT, LU, MC, NL, PT, SE, TR).
- (26) Publication Language: English
- (71) Applicant: OPTICAL COATING LABORATORY, INC. [US/US]; c/o Hogan, Silvia, 2789 Northpoint Parkway, Santa Rosa, CA 95407-7397 (US). Published:
— with international search report
- (72) Inventors: HICHTWA, Bryant; 4100 Pressley Road, Santa Rosa, CA 95404 (US). MARXER, Cornel; Institute of Microtechnology, University of Neuchatel, ru Jaquet-Droz 1, For two-letter codes and other abbreviations, refer to the "Guidance Notes on Codes and Abbreviations" appearing at the beginning of each regular issue of the PCT Gazette.

(54) Title: BI-STABLE MICRO SWITCH

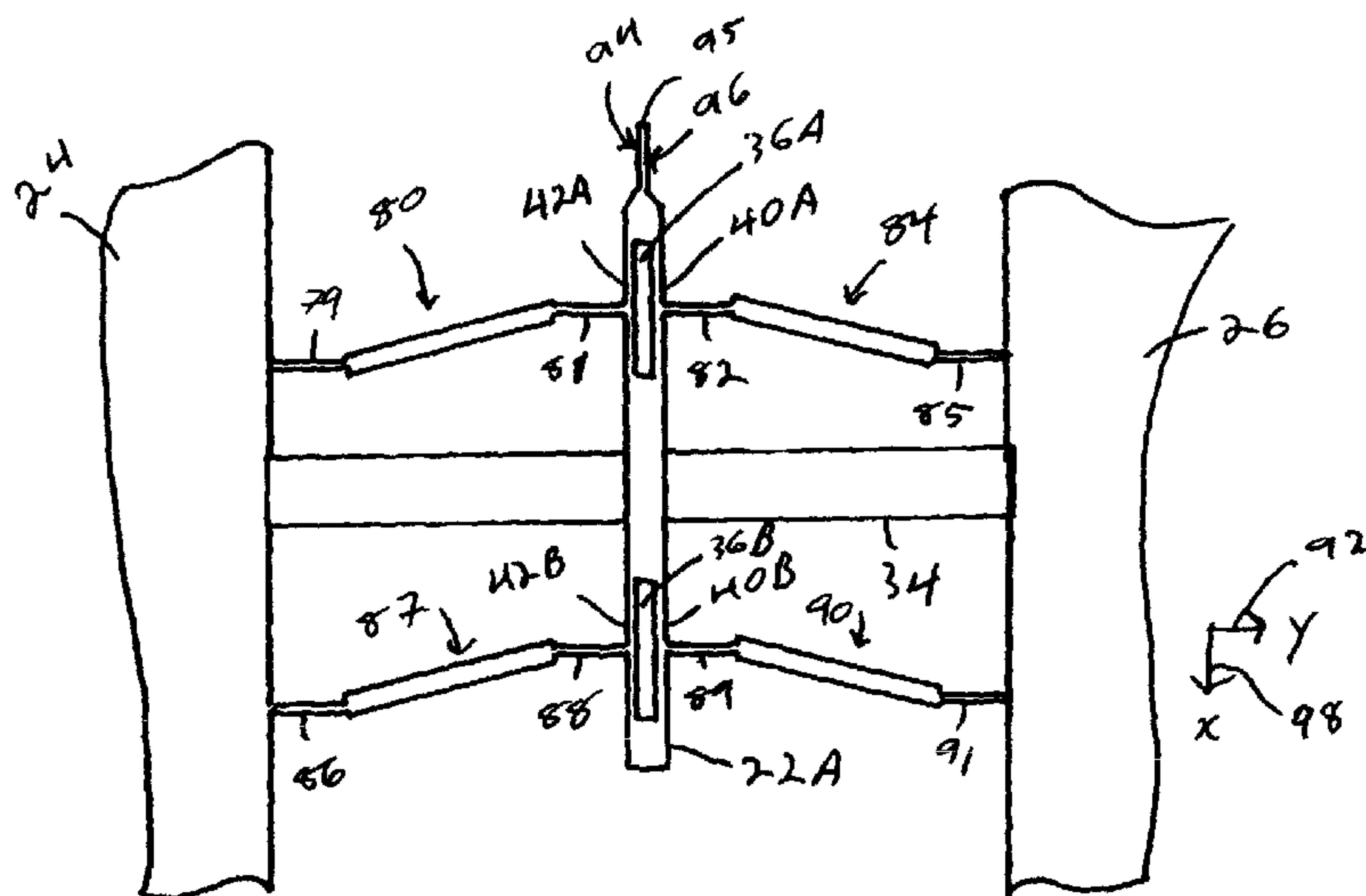

(57) Abstract: A bi-stable micro-machined electro-mechanical system ("MEMS") switch. In a preferred embodiment, the bi-stable MEMS switch is used in an NXN optical signal switching system. Spring arms act in conjunction with a hollow beam portion of a movable center body of the switch to accommodate strain in the arms as the switch is moved from a first position to a second position, thus avoiding buckling of the spring arms. Both the first and second switch position occur at local minimums of mechanical potential energy, thus providing two stable switch states. The center body is moved in relation to static portions of the switch by an actuator, such as an electro-static comb drive.

WO 02/075428 A1

BI-STABLE MICRO SWITCH

CROSS-REFERENCE TO RELATED APPLICATIONS

5 This patent application is being concurrently filed with U.S. Patent
6,388,359 issued on May 14, 2002, entitled "Method of Actuating MEMS switches" by
Duelli et al.; and U.S. Patent 6,210,540 issued on April 3, 2001, entitled "Method and
Apparatus for Depositing Thin Films on Vertical Surfaces" by Hichwa.

10 STATEMENT REGARDING FEDERALLY SPONSORED RESEARCH OR DEVELOPMENT

Not applicable.

REFERENCE TO MICROFICHE APPENDIX

15 Not applicable.

FIELD OF THE INVENTION

20 The present invention is generally related to switches for use in micro
systems, and more particularly to a MEMS switch capable of latching in either of two
switch positions.

BACKGROUND OF THE INVENTION

25 Optical switches can be used in a variety of applications, such as optical
fiber transmission networks, to route optical signals along various signal paths. An optical
switch typically has an optical element, such as a mirror or a filter, that is switched into
and out of a path of an optical signal beam. Switches are typically characterized by the

number of input and output port, referred to as $N \times N$. For example, a 1×2 switch would switch one input between two outputs.

Switches can often be described as “latching” or “non-latching”. A latching switch reliably remains in a known position, even if the power is removed or lost. A non-latching switch may revert to an unknown position, or even a position intermediate between switch states, when the power is lost, for example if current provided to an electro-magnetic solenoid or thermal actuator is lost. One type of latching switch reverts to a known default position (state), no matter what state the switch was in when power was lost. Another type of latching switch preserves the switch state, no matter what that state was. The latter case is known as a “bi-stable” switch.

Bi-stable optical switches are desirable for use in optical telecommunication systems because they preserve the network configuration associated with the position of the switch(es) when the power was lost. Various approaches have been used to produce bi-stable optical switches. One approach uses a permanent magnet in conjunction with a piece of magnetic material to hold the switch element in the desired position. Other approaches use a mechanical latch to hold the switch element in the desired position.

In a particular application, as illustrated and described in U.S. Patent No. 5,994,816 entitled THERMAL ARCHED BEAM MICROELECTROMECHANICAL DEVICES AND ASSOCIATED FABRICATION METHODS by Dhuler et al., issued Nov. 30, 1999, a mechanical latch is used in a micro-electro-mechanical system (“MEMS”) (*See, e.g.* Fig. 11, ref. nums. 69 and 68c). A thermal arched beam actuator is used to move a switch element back and, with a thermally activated latch holding the switch element in the desired position(s). However, having contact surfaces between the latch and the switch element can result in the mechanism sticking or produces “sticktion (i.e. sticking friction), thus altering the force required to change switch states. This sticking or sticktion can not only affect the reliability of switch operation, but also affect the timing of the switch, particularly with fast (i.e. ≤ 1 ms) in light of the need to time the operation of the latch with the operation of the electrostatic comb.

U.S. Patent No. 5,994,816 also describes a latching mechanism that uses an electrostatic field to clamp a movable portion of the switch to the switch body (substrate). Clamping allows the relatively high current flow to the thermal beam actuator to be removed without losing the clamped switched state, thus conserving power. However, if

3

the voltage to the electrostatic clamping circuit is removed the switch may revert to a state other than what was previously held.

Accordingly, it is desirable to provide a bi-stable MEMS switch without mechanical contacting surfaces between moving and static surfaces of the switch. It is further desirable that the optical switch be repeatable and have a high switching lifetime, and maintain a present switch state when power to the switch is removed.

SUMMARY OF THE INVENTION

The present invention provides a bi-stable MEMS switch without contact surfaces between the moving and static portions of the switch. In a preferred embodiment, a switch element or center body is movable in relation to the switch body or substrate (i.e. MEMS chip). The switch element is suspended between portions of the switch body by a plurality of spring arms attached at walls of hollow body portions of a center beam and can serve to operate in a relay, a valve, or an optical switch, for example. An actuator, such as an electrostatic comb drive motor, thermal beam actuator, or magnetic motor, provides a motive force to the switch element according to an electronic switch signal. The spring arms hold the switch element in place in relation to the switch body and in one of two switch positions, whether or not the electronic switch signal continues to be applied.

The switch is cycled between states by appropriate electronic switch signals. For example, if an electrostatic comb drive motor is used, a first electronic switch signal, such as a pulse or series of pulses, causes the switch to assume a first switch position. A second electronic switch signal causes the switch to assume a second switch position. The electrostatic comb drive motor uses two electrostatic arrays, one array configured to move a movable portion of the switch in a first direction, and the other array configured to move the movable portion of the switch in a second direction in response to applied electrical signals. In the event of a thermal beam motor, an electric current might be temporarily applied to a first set of heaters to set the switch in a first position, and a temporary electric current might be applied to a second set of heaters to set the switch in a second position. Using either type of actuator, the switch will remain in its present state if power is lost, but typically power is removed to conserve power consumption of the switch.

The spring arms and hollow beam walls deform in response to the motive force of the actuator, and attain an equilibrium position in either of the switch states. In a

preferred embodiment, one switch position has a lower potential energy than the other switch position; however, the switch is bi-stable.

BRIEF DESCRIPTION OF THE DRAWINGS

5 Fig. 1A is a simplified diagram of a portion of a bi-stable latching MEMS switch device according to the present invention in a first position;

Fig. 1B is a simplified diagram of the portion of the device shown in Fig. 1A in a second position;

10 Fig. 1C is a simplified graph of the potential mechanical energy state of a bi-stable switch during operation according to an embodiment of the present invention;

Fig. 2A is a simplified representation of a portion of a switching device according to the present invention illustrating various aspects used in modeling the operation of the device;

15 Figs. 2B-2D are simplified representations of a spring model of a bi-stable switch according to an embodiment of the present invention;

Fig. 3A is a simplified top view of a portion of a switch device and electrostatic comb drive actuator according to an embodiment of the present invention;

Fig. 3B is a simplified cross section of a portion of a MEMS device illustrating separation between the substrate and movable portions of the device;

20 Fig. 4A is a simplified perspective view of a portion of a MEMS chip according to the present invention illustrating 2×2 optical switch in the bar state;

Fig. 4B is a simplified perspective view of the portion of the MEMS chip in Fig. 4A in the cross state;

25 Fig. 4C is a simplified side view of a packaged bi-stable optical MEMS switch according to an embodiment of the present invention;

Fig. 4D is a simplified side view of a packaged bi-stable optical MEMS switch according to an embodiment of the present invention;

Fig. 5A is a simplified graphical representation of a switching signal according to an embodiment of the present invention;

30 Fig. 5B is a simplified graphical representation of another embodiment of a switching signal according to an embodiment of the present invention; and

Figs. 6A and 6B are simplified flow charts of processes according to embodiments of the present invention.

DETAILED DESCRIPTION OF THE INVENTION

I. Introduction

The present invention provides a bi-stable MEMS switch that retains its switch state when power to the device is removed or lost. A plurality of spring arms
5 deform in response to movement of a center body of the switch that is coupled to an actuator. The actuator provides motive force to the center body, but is not required to maintain a switch state. Generally, the spring arms start at a stable equilibrium state, increase in potential mechanical energy through a maximum as the center body is moved
10 from one switch position to another, and then assumes a second stable equilibrium, i.e. within a potential energy well below the maximum, in the second switch position. The first position is generally the as-fabricated state, and the spring arms store mechanical energy in the second state, thus a non-symmetrical switching signal can be employed, namely the switch signal applied to switch from the first state to the second state might provide less energy than to switch from the second state to the first state. In a particular
15 embodiment, an electrostatic comb drive actuator is used. The current drawn by such an actuator is so low that the switch can be "strobed", which means that a switch signal may be applied to the switch, even if the switch is already in the desired switch state.

II. A Bi-Stable MEMS Switch

20 Fig. 1A is a simplified top view of a portion of a bi-stable MEMS switch 20 according to an embodiment of the present invention in a first latched switch state. The switch includes a movable center body 22 attached to fixed (static) portions of the switch 24, 26 by spring arms 28, 30. An actuator 34, such as a thermal beam actuator, electrostatic comb drive, or electromagnetic actuator, is coupled to the center body, and
25 provides a motive force to the center body to move it between a first latched switch state and a second latched switch state. The center body includes a hollow beam portion 36 that has a hollow center portion 38 and hollow beam walls 40, 42. The hollow beam walls act in conjunction with the spring arms 28, 30 to allow deflection of switch elements and storing of spring energy. The spring arms 28, 30 are essentially opposite each other at the
30 walls of the hollow beam portion. In a preferred embodiment, two pairs of spring arms, each in conjunction with a hollow beam portion, are used to stabilize and guide the center body between switch positions. In alternative embodiments, other mechanical elements might be used to guide and stabilize the center body. The A further understanding of the operation of the switch elements is provided in reference to Figs. 2A-2D, below.

6

The MEMS switch may be made in accordance with various known fabrication processes. In a particular process, the switch is made on a commercially available silicon-on-insulator ("SOI") wafer. The SOI wafer includes a single-crystal base and approximately 2 microns of thermally grown silicon oxide between the base and approximately 73 microns of single-crystal silicon overlying the silicon oxide. The SOI wafer was made according to a wafer bonding process, but it is understood that the wafer is described for purposes of illustration and discussion only, and might be made according to other processes or with other types or thicknesses of layers.

Features of the MEMS switch are formed in the thin layer of silicon overlying the oxide layer using a highly directional etch technique, such as a biased plasma etch technique, as are well known in the art. A hydrofluoric acid ("HF") etch process is used to remove the oxide underneath portions of the switch movable in relation to the base, such as the spring arms and center body. The HF etch is generally isotropic, and removes a portion of the oxide underlying static portions of the switch, but this does not significantly affect the characteristics, performance, or the reliability of the switch. Access by HF to the portions of oxide to be removed is facilitated by keeping the sections of movable portions of the switch relatively thin. In general, the undercutting of static portions of the switch, which generally have a single-sided exposure to the HF, will be half the distance between edges of movable portions having double-sided exposure to the HF.

Fig. 1B is a simplified top view of the portion of the bi-stable MEMS switch 20 shown in Fig. 1A in a second latched switch state. The actuator 34 has applied a motive force to the center body 22 to retract the center body from the first switch position. The terms "extend" and "retract" are used for purposes of convenient discussion only. The spring arms have assumed a different shape from their shape represented in Fig. 1A. This difference in shape will be referred to as "deformation", which may induce a variety of shapes in the spring arms, such as an "S" shape or a "C" shape. The combination of the spring arms in conjunction with the walls of the hollow beam portion provide a linear spring-type of energy storage, as opposed to the non-linear buckling that can arise with conventional non-compressible arms.

If arms similar to the spring arms of the present invention are used with a solid center beam, the strain in the arms can build up in the arm material to a critical degree and cause buckling of the arms, i.e. twisting or bending out of the plane of the substrate. This buckling is typically non-linear, and can result in unpredictable switch

7

behavior. In the present invention, the deformation of the hollow beam portion of the center body provides a restoring (spring) force proportional to the displacement of the wall. The displacement of the wall at least partially accommodates the strain in the arms, thus avoiding buckling.

5 Fig. 1C is a simplified graph 50 of potential energy 52 versus displacement of the center body in reference to the static switch body for a switch according to an embodiment of the present invention. The as-fabricated position 56 of the center body will be given the reference of zero displacement 54 and zero potential energy for purposes of illustration, and will be referred to as the first switch position. Moving the center body
10 in either a positive or negative direction increases the potential of the switch. For purposes of illustration, movement toward the second switch position will be termed a positive displacement.

As the center body is moved toward the second switch position 58, the potential increases to a potential maximum 60, and then decreases to a local minimum 62
15 at the second switch position. Although the local minimum 62 has a higher potential than the first switch position (another potential local minimum), it is stable because energy is required to move the switch away from the local minima. The potential maximum represents a compressed state of the spring arms and/or the hollow beam walls. Some of this energy is released as the center body moves to the second switch position.

20 Generally, switching from the first switch position to the second switch position requires sufficient energy to move the center body from the reference (zero potential) position to the potential maximum. However, switching from the second switch position to the first switch position may be different, requiring the energy necessary to move the center body from the second switch position over the potential maximum, which
25 is generally less but could be essentially the same or even more.

III. Analytical Model

Fig. 2A is a simplified representation of a portion of a switching device according to the present invention illustrating various aspects used in modeling the
30 operation of the device. For purposes of illustration, the actuator described is an electrostatic comb drive. The force generated by a voltage V in an electrostatic comb drive actuator can be expressed by the formula:

$$F_{es} = n\epsilon \frac{h}{g} V^2 \quad (\text{Eq. 1})$$

8

n is the number of comb fingers. A typical figure in the existing designs is around 100. The height of the structure h is about 70-75 μm . The gap g between the comb fingers can be reduced down to 4 μm . The dielectric constant of the medium (vacuum, gas or fluid) between the comb drive fingers is ϵ .

5 Using these values one can calculate the typical force generated by a comb drive actuator for a given voltage in different media:

	Air	Oil
Force at 70 V	80 μN	160 μN

10 Thus, application of 70 V to the comb actuator should switch the suspension structure between its two bi-stable states if the force required to pass the unstable barrier is <160 μN for oil filled devices and <80 μN for air filled devices.

The bi-stable behavior of the structure in Figs. 1A and 1B arises from a lateral force which holds the structure in its deformed equilibrium state. The spring model shown in Figs. 2B-2D more clearly illustrates the forces acting in the structure of Fig. 2A as it is switched between states. Figs. 2B-2D are not representative of the actual physical deformation in the MEMS device, but rather are illustrative of the analytical model. In the rest position, i.e. such as the structure as it is fabricated, all springs are in a released state (Fig. 2B). When the structure is moved in the longitudinal direction both the lateral springs 70, 71 as well as the longitudinal spring 72 are compressed. After half the deformation (Fig. 2C), the lateral springs 70, 71 start decompressing again, which results in a force acting into the longitudinal direction. If this force is higher than the restoring spring force from the longitudinal springs, the structure will have two static equilibrium states. The compression of the hollow beam walls (see e.g. Fig. 2a, ref. num. 42A) are represented by the lateral springs 70, 71 and the restoring force of the spring arms is represented by the longitudinal spring 72.

The structure modeled in Figs. 2B-2D can be realized by fabrication of the structure shown in Fig. 2A. The longitudinal spring 72 of Fig. 2B is formed by the 4 spring arms 80, 84, 87, 90 which have a total linear spring constant of:

$$k_h = 2 \frac{Eht_h^3}{4l_h^3 - 6l_h^2L_h + 3l_hL_h^2} \quad (\text{Eq. 2})$$

Where E is the Young's modulus of silicon, typically about 170 GPa, h is the height of the structure (nominally 75 μm), t_h is the thickness of the flexible hinges 79, 81, 82, 85, 86, 88, 89, 91, l_h is the length of the hinges (assumed to be the same for all hinges in this model), and L_h is the total length of one suspension arm (also assumed to be the same for all arms in this model). The factor 2 takes into account the total number of 4 spring arms.

The 4 lateral springs have a total spring constant of:

$$k_l = 4 \frac{16Et_l^3h}{l_l^3} \quad (\text{Eq. 3})$$

where t_l and l_l are the thickness and respectively the length of this double clamped suspension. The suspension is double clamped because both the first opposite pair of arms 80, 84 and the second pair of arms 87, 90 (in conjunction with the respective hollow beam walls 42A, 40A and 42B, 42B) clamp the center body 22A in one of the two switch states. The distance between the two equilibrium points can be adjusted by the initial offset.

To find an analytical expression describing structure of Fig. 2A, we will first consider the flexible hinges infinitely compliant, i.e. $k_h = 0$. Applying a force F_y in the y direction 92 at a clamping point creates a reaction force F_x in x direction 98 on the mobile structure (i.e. center body). These forces are related to one another through the expression below:

$$F_x = \frac{x-d}{L_h} F_y \quad (\text{Eq. 4})$$

where x is the longitudinal displacement of the mobile structure. In a particular embodiment an optical element, such as a mirror, is mounted or formed on a mounting portion 95 of the center body. When the mobile structure is displaced in the x direction 98, the lateral springs will be deformed by the amount Δy :

$$\Delta y = \sqrt{d^2 + L_h^2} - \sqrt{(d-x)^2 + L_h^2} \quad (\text{Eq. 5})$$

The force F_{xy} in x direction resulting from this Δy can be obtained by multiplying this deformation by the spring constant k_l and replacing F_y in equation (Eq. 4):

$$F_{xy} = \frac{d-x}{L_h} k_l \left[\sqrt{d^2 + L_h^2} - \sqrt{(d-x)^2 + L_h^2} \right] \quad (\text{Eq. 6})$$

10

The expression in the brackets [...] is always greater than or equal to zero. The sign of the force F_{xy} is thus only determined by the expression $(x-d)/L$, which changes its sign when x becomes larger than d , i.e. when the structure passes its center point (as in Fig. 2C).

In order to obtain the desired bi-stable behavior this force F_{xy} should be higher than the
 5 restoring spring force once the structure has passed into the position shown in Fig. 2D, as described above in conjunction with Fig. 1C.

The restoring spring force from the flexible hinges can be expressed by:

$$F_{xx} = xk_h \quad (\text{Eq. 7})$$

Finally the static equilibrium can be written as:

$$10 \quad F_{es} - F_{xx} - F_{xy} = 0 \quad (\text{Eq. 8})$$

which states, that the external force, i.e. the electrostatic drive F_{es} , has to counterbalance the restoring spring force F_{xx} from the flexible hinges and as well as the force F_{xy} from the lateral springs. Those skilled in the art will appreciate that the model provided above is simplified and exemplary only, and that other switch structures might be more accurately
 15 represented by other models.

IV. Further Details of an Exemplary Device

Fig. 3A is a simplified top view of a portion of a MEMS switch device and electrostatic comb drive according to an embodiment of the present invention. The spring
 20 arms 80, 84, 87, 90; hinges (not shown in this figure); center body 22A including a mounting portion 95; and actuator 34 are fabricated in a nominally 75 micron-thick layer of single-crystal silicon overlying a thin (e.g. 2-5 micron) silicon oxide layer on a silicon wafer substrate. The actuator includes a first section 35 and a second section 33. Each section includes an array of opposing "fingers". When a voltage is applied to the opposite
 25 halves (not shown) of the first section, the center body is retracted from its as-fabricated position. When a voltage is applied to the opposite halves of the second section, the center body is extended toward its as-fabricated position.

The mounting portion 95 is about 1 micron thick, but can be thicker if desired. In an exemplary embodiment a thin film of reflective material is deposited on a
 30 vertical (to the substrate) surface of the mounting portion to serve as a mirror that is switched in and out of an optical signal path. In a further embodiment, a reflective coating is formed on both surfaces 94, 96 of the mounting portion and the mirrors are switched into and out of two optical paths to form a 2×2 optical switch. The mirrors could be, for example, sputtered thin film layers of gold about 1000 Angstroms thick, or other metals or

11

reflective coatings. It is generally desirable that the mirror surface be smooth, highly reflective (>97%) in the wavelengths of interest, and not transmit light from one side of the mounting portion to the other. The etched surface of the mounting portion can be smooth enough to serve as a suitable mirror substrate.

5 Additional features include channels, or grooves, 100, 102, 104, 106, for mounting four optical fibers (not shown) to the MEMS chip 108. The grooves were formed in the structure concurrently with the electrostatic comb drive actuator and other features of the device using a deep reactive ion etch (DRIE") process. The MEMS chip is sawn or otherwise separated from the substrate and is about 3.4 mm by 4 mm.

10 Fig. 3B is a simplified cross section of a portion of a MEMS switch according to an embodiment of the present invention showing the silicon substrate 110, the oxide layer 112, and the overlying silicon layer 114. The oxide layer has been removed from beneath the center body 22 (the hollow portion) and the spring arms 28, 30 with an HF etch, which has formed small undercuts 116 underneath the static portions of
15 the overlying silicon layer. Devices made in accordance with the present invention have been cycled between two bi-stable states for between 200 million and 1 billion complete cycles depending on the particular testing protocol. No device failures have been observed in these tests. Other material systems may be used with suitable modifications to the fabrication techniques, if necessary.

20

V. A Bi-Stable MEMS Optical 2×2 Switch

Fig. 4A is a simplified perspective view of a portion of a MEMS chip according to the present invention used in an optical switch 120 in a "bar" state. Mirrors have been formed on the surfaces 94, 96 of the mounting portion 95 of the center body. A
25 first input fiber 122 provides an optical signal, represented by the arrow 124 to a mirror coating 126 on the first surface 96 of the mounting portion when the center body is extended, and reflects the optical signal to a first output fiber 128. A second input fiber 130 provides a second optical signal, represented by the arrow 132, to a mirror coating (hidden in this view) on the second surface 94 of the mounting portion, which reflects the
30 second optical signal to a second output fiber 134.

Fig. 4B shows the optical switch of Fig. 4A in a "cross" state with the center body retracted so that the mirrors are not in the optical paths of the first or second optical signals from the first and second input fibers. In this switch state, the first optical signal couples to the second output fiber 134 and the second optical signal couples to the

first output fiber 128. The angle between the first input fiber and first output fiber (and similarly second input fiber and second output fiber) is 90° , but in an alternative embodiment the angle is 70° to reduce polarization-dependant losses. Other angles may be used.

5 Although the embodiment described in conjunction with Figs. 4A and 4B relate to optical fiber inputs and outputs, it is understood that other optical transmission lines may be used, such as thin-film waveguides, and that the optical fibers may be mechanically coupled to the MEMS chip in a variety of fashions to result in an optical switch. In a particular embodiment, lensed waveguides are employed to improve the
10 insertion loss of the switch. For example, mounting cleaved fibers at a separation suitable for inserting the mounting portion of the MEMS switch in a fiber-to-fiber insertion loss of about 1.3-1.5 dB. Further providing a lens (i.e. a light-gathering structure) on each fiber end reduces the insertion loss. If an anti-reflective ("AR") coating is also provided to the lensed end the fiber-to-fiber insertion loss can be reduced to about 0.1-0.3 dB. Lensed
15 fibers are available from suppliers such as OPTOSPEED SA of Mezzovico, Switzerland and HIGHWAVE OPTICAL TECHNOLOGIES, of Lannion, France. Alternatively, a discrete lens could be attached to the fiber end. The lensed fibers available from OPTOSPEED SA are tapered to provide a light focusing/gathering function, not for merely mechanical purposes, although the tapered aspect of the fiber end allows the fiber end to be brought
20 into closer proximity with the mirror or cross fiber, thus improving insertion loss.

 Although as little as 0.1 dB of insertion loss between fibers is achievable in the cross mode, this generally requires optical alignment of the cross fibers. With this alignment, about 0.4 dB of insertion loss occurs between fibers in the bar mode of operation. This results in about 0.3 dB difference in insertion loss depending on which
25 state the switch is in (i.e. the optical signal is reflected or directly transmitted to the selected output). To reduce this difference, the fibers can be intentionally mis-aligned or "de-focused" in the cross mode to result in increased insertion loss. The terms "focus" and "de-focus" are used for convenience and illustration, in light of the dimensions of the structures and wavelengths of the light signals involved. In some applications, aligning
30 the fibers off-axis may improve insertion loss in the bar mode because the thickness of the mounting portion creates a difference in signal path length. In a particular embodiment, the cross path fibers with aligned to produce an insertion loss in the cross mode of about 0.3 dB, thus the difference in insertion loss between the cross path and the bar path was less than about 25%, which is desirable to avoid signal level difference between the

selected switch states. Otherwise, a gain stage might (e.g. a light amplifier such as a doped fiber) in series with the signal might have to be adjusted for gain depending on the switch state.

Fig. 4C is a simplified side view of a packaged bi-stable optical MEMS switch 140 according to an embodiment of the present invention. The actual switching device is packaged in a TO-5 package 142 that provides a hermetic seal and protects the device from external forces as well as a handling and mounting convenience. In a preferred embodiment, a low-profile TO-5 package having a can 144 height of about 4-5 mm is used. The TO-5 package has a small footprint, with a can diameter of about 8-9mm. Alternatively, a TO-8 package having a can diameter of about 13-15 mm may be used. Packaging the switch in such a small package is enabled by the combination of the lensed fibers with the bi-stable micro switch. The latching spring arms avoid the need for separate latching .

Input and output optical signals are provided by four (4) optical fibers 122, 130, 134, one of which is not seen in this view but essentially is disposed opposite to fiber 134 and normal to fibers 122 and 130 to form a "+" configuration when viewed from the top. The fibers are attached to the MEMS device by cementing them in grooves that are etched into the silicon MEMS chip, and brought through the can 142 of the package. The can 42 is mounted to the header 146 of the package. The fibers are actively aligned during assembly of the hybrid MEMS chip/fiber switch. Two isolated (from the header/package) electrical leads 148, 150 are brought out to provide isolated electrical energy to the actuator when using an isolation chip mounting technique. Alternatively, a single isolated electrical lead may be used in conjunction with some types of actuators. In yet another configuration two isolated leads are provided, one for a "push" signal and one for a "pull" signal, with a common package ground being provided by a ground pin 152. In any case, no more than two isolated electrical leads are needed because the latching technique of the present invention does not require a separate latching/de-latching signal, rather, only the actuator signal. A two-lead (isolated) configuration allows the packaged MEMS switch to be electrically isolated from other components, which may be desirable in the case of high-voltage (greater than 40 V) switching signals. Alternatively, a voltage converter chip can be included in the package to allow a relatively low voltage (e.g. 5 V) to be delivered to the package, which is then boosted to a voltage appropriate for driving the actuator (e.g. 40-80 V) inside the package. Electrical contacts, which provide the driving signal for the

14

switch, are ultrasonic wire bonded from the isolated electrical leads in the header or otherwise electrically coupled to appropriate pads on the MEMS chip.

Fig. 4D is an alternative embodiment of a packaged optical MEMS switch 140A according to an alternative embodiment of the present invention. The four optical
5 fibers 122, 130, 134, and 128 are brought out through the header 146 of the package, rather than the can 142. A seal is made between the fibers and the header with epoxy or other sealant.

VI. MEMS Actuator Signal Waveforms

10 Novel waveforms are applied to the device to optimize switching speed and stable switch operation, and hence reliable optical output. In prior devices it has been common to provide a simple "square wave" electrical pulse to electrostatic comb
actuators. Referring to Fig. 1C, particular attention is drawn to the higher stable well 62 and the potential maximum 60. Depending on the design of the switch, the movable
15 portion of the switch can oscillate or "ring" after a switching pulse is applied. Movable portions with certain mass in combination with spring or actuator elements and dampening characteristics can overshoot the well position and spring back toward the potential
maximum. The waveforms provided below are exemplary only to illustrate the concept that after the first, switching pulse, a second pulse is applied. The second pulse is timed to
20 retard the acceleration of the actuator toward the target local equilibrium position or potential well, such acceleration being caused by the restoring force of the spring arms and/or hollow beam walls.

Simple minor ringing might cause variations in the optical signal amplitude. More severe ringing might move the mirror in and out of the optical input
25 signal path(s), causing drop-out of the desired output and cross-talk in the undesired output. In some cases, overshoot might cause the movable body to spring back over the potential maximum, and settle in another (undesired) potential well, thus placing the switch in a non-selected state. In prior switches, oil has been applied to the switch to increase dampening. However, embodiments of the present invention avoid such
30 measures by applying switching (actuator) waveforms having multiple segments.

Fig. 5A is a simplified graph of voltage versus time for a voltage waveform applied to a MEMS switch according to an embodiment of the present invention. The voltage may be applied directly from a signal generator or similar source, or a lower voltage may be applied to a voltage converter or amplifier. In a preferred embodiment, a

15

comb drive with two drive units is employed. The first drive unit causes the center body to retract when a “push” signal is applied. The second drive unit causes the center body to extend when a “pull” signal is applied to the second drive unit. In either case, the fingers of the respective drive units are moving toward each other in response to an electric signal.

5 A first pulse 200 is provided to a first section of the electrostatic comb drive to push the center body from its rest (as-fabricated) position over the potential maximum. This pulse is about 83 V with a pulse width of about 160 micro-seconds. Those skilled in the art will appreciate that the pulse shown is idealized, and that the pulse form typically has some rounding of the corners and sloping of the walls. Furthermore, 10 the voltage and duration are exemplary only, generally chosen according to a specific embodiment of switch to reliably and quickly drive the switch from a first state (Fig. 1C, ref. num. 59) to a second state (Fig. 1C, ref. num. 62) over the potential maximum. Other switches might optimally switch states with different voltages and pulse durations according to the mass and spring constant of the movable portions of the switch, among 15 other factors, such as the difference between the potential well(s) and the potential maximum.

A second pulse 202 is provided to retard the acceleration of the center body after it has passed the potential maximum, but before the center body has reached the second potential well center. The second pulse slows down, or decelerates, the center 20 body, which is typically accelerating from the potential maximum due to the spring energy stored in the spring arms and hollow beam walls. The second pulse 202 is provided to a second section of the electrostatic comb drive to pull the movable portion of the switch in the opposite direction from the motion caused by the first pulse. It is understood that each of the two sections of the comb drive operates by attracting one half of the section to an 25 opposing half of the section, and that “push” and “pull” are defined in terms of the movement of the center body. Furthermore, in a particular embodiment the MEMS device is fabricated with the center body in an extended (bar) position, thus “pushing” from this position up the potential energy curve involves retracting the center body. The second pulse has a voltage of about 48 V and a duration of about 140 micro-seconds. The second 30 pulse in Fig. 5A is shown as being inverted merely to illustrate that it has a different effect on the center body, and does not imply polarity of either pulse. A dwell period 204 of about 40 micro-seconds is provided between the first and second pulses to account for variations in switch fabrication, actuator performance, and the electrical pulse supply, for example. Ideally, an electrostatic switching signal waveform would provide enough force

16

when applied to the actuator to rapidly accelerate the center body past the position of the potential maximum, and then start decelerating the center body in a fashion that would rapidly allow the center body to assume the desired switch position with minimal ringing or overshoot.

5 Fig. 5B is a simplified graph of voltage versus time illustrating another waveform according to an embodiment of the present invention. A first push pulse 200 is applied, as before in Fig. 5A; however, the dwell period 206 is increased to allow the center body to travel through the desired potential well and spring back through the well center toward the potential maximum. After the dwell period, a second push pulse 208 is
10 applied to keep the center body from traveling too far toward or over the potential maximum, thus reducing ringing and overshoot.

The switching waveforms illustrated in Figs. 5A and 5B are for switching from a first state to a second state. A different waveform might be desired for switching from the second state to the first state. For example, referring again to Fig. 1C, the energy
15 required to overcome the potential maximum from the lower well to the higher well is greater than the energy to overcome the potential maximum from the higher well to the lower well. Thus, in a further embodiment, two different waveforms are used to switch from opposite states, in other words the switching waveforms (signals) are non-
20 symmetrical in that they deliver different energies to the actuator depending on the starting and ending switch states. The pulse width, as well as the voltage, and temporal shape and timing may be modified. For example, when switching to the lower well position, more spring energy will be released from the spring arms and hollow beam walls, thus a longer and/or higher voltage pull pulse (ref. Fig. 5A, ref. num. 202) is appropriate. Using the
25 appropriate amount of switching energy reduces overshoot when switching from a higher potential state and reduces the power required for a switch cycle, which is desirable in power limited situations, such as solar powered or battery powered applications, or environments where heat dissipation from the power supply is critical.

The above illustrations are merely examples of methods to apply a second electronic signal to a MEMS switch to improve operation of a MEMS switch. In the
30 particular spring embodiments described above, a second pulse may be applied to retard acceleration as the center body travels past the potential maximum position toward the second well position. The spring energy stored in the latching spring arm-beam side wall structure contributes to this acceleration. Other MEMS switches may be improved and switch mechanisms may similarly benefit from an electronic switching signal applied as a

series of electronic signals separated by selected periods of time. It is specifically understood that it may be desirable to apply more than two segments (e.g. pulses) of a switching signal to perform the desired switching function.

Fig. 6A is a simplified flow chart of a process of operating 600 a MEMS switch according to an embodiment of the present invention. A MEMS switch is provided in a first position (step 602). A first pulse of a switching signal is provided to the MEMS switch to move the switch toward a second position (step 604). After waiting for a selected dwell period (step 606), a second pulse (step 608) is provided to the MEMS switch to place the switch in a second position.

In a particular embodiment the MEMS switch includes an electro-static comb drive actuator, the first pulse is a push pulse and the second pulse is a pull pulse. In another embodiment, both pulses are push pulses. In another embodiment, the switching from the first position (switch state) to the second is accomplished with the application of the switching signal, and switching back from the second position to the first position is accomplished with stored mechanical energy. In a non-latching switch, the switching signal (i.e. the signal applied to change states) may be followed with a switch holding signal (i.e. the signal applied to hold a state). In some embodiments, these two types of signals may be continuous in time.

Fig. 6A is a simplified flow chart of a process of operating 600 a MEMS switch according to an embodiment of the present invention. A MEMS switch is provided in a first latched position (step 602). A switching signal is provided to the MEMS switch to latch the switch in a second latched position (step 604). No latching or de-latching signal apart from the switching signal is required to change switch states.

Fig. 6B is a simplified flow chart of a process of operating 610 a MEMS switch according to a further embodiment of the present invention. A MEMS switch is provided in a first latched position (602). A first switching signal including a first pulse, a first dwell period, and a second pulse is provided to the MEMS switch to latch the switch in a second latch position (step 614). In further operation, a second switching signal including at least a third pulse is provided to the MEMS switch to latch the switch in the first latched position (616).

While the description above provides a full and complete disclosure of the preferred embodiments of the present invention, various modifications, alternatives, and equivalents will be obvious to those of skill in the art. For example, while embodiments of the invention have been described primarily with reference to monolithic MEMS

18

electrostatic comb drive actuators embodiments of the present invention might employ other types of actuators, such as various other electrostatic actuators, thermal actuators, and magnetic actuators. Accordingly, the scope of the invention is limited solely by the following claims.

5

What is claimed is:

- 1 1. A bi-stable micro-electro-mechanical system (“MEMS”) switch
2 comprising:
3 a static portion (24);
4 a center body (22) movable with respect to the static portion in response to
5 operation of
6 an actuator (34) coupled to the static portion and to the center body, the
7 center body being further coupled to the static portion with
8 a first pair of spring arms (28, 30) coupled to
9 a hollow beam portion (36) of the center body.
- 1 2. The bi-stable MEMS switch of claim 1 further comprising a second
2 pair of spring arms.
- 1 3. The bi-stable MEMS switch of claim 1 wherein at least one of the
2 first pair of spring arms includes a flexible hinge (79).
- 1 4. The bi-stable MEMS switch of claim 2 wherein each of the first pair
2 and the second pair of spring arms includes a flexible hinge.
- 1 5. The bi-stable MEMS switch of claim 1 wherein the actuator
2 comprises an electro-static comb drive.
- 1 6. The bi-stable MEMS switch of claim 1 wherein the center body
2 includes a mounting portion (95) with a mirror coating (126).
- 1 7. The bi-stable MEMS switch of claim 6 wherein the mirror coating
2 comprises a sputtered layer of gold having a thickness between about 700-1000
3 Angstroms.
- 1 8. The bi-stable MEMS switch of claim 2 wherein the center body
2 includes a first hollow beam portion (36A) and a second hollow beam portion (36B), the
3 first pair (80, 84) of spring arms being coupled to the first hollow beam portion and the
4 second pair of spring arms being coupled to the second hollow beam portion.

1 9. A bi-stable micro-electro-mechanical system (“MEMS”) switch
2 comprising:
3 a static portion (24);
4 a center body (22A) having a first hollow beam portion (36A) and a second
5 hollow beam portion (36B), and a mounting portion (95) with a mirror disposed on at least
6 one vertical surface of the mounting portion, the center body being movable with respect
7 to the static portion in response to operation of
8 an electrostatic comb drive coupled to the static portion and to the center
9 body, the center body being further coupled to the static portion with
10 a first pair of spring arms and a second pair of spring arms wherein each of
11 the spring arms includes at least one flexible hinge, and the first pair of spring arms is
12 coupled to the first hollow beam portion and the second pair of spring arms is coupled to
13 the second hollow beam portion.

 10. A bi-stable micro-electro-mechanical system (“MEMS”) switch
15 comprising:
 a static portion;
 a center body with a hollow portion, the hollow portion having a first
wall and an opposite wall, the center body being coupled to the static portion by
 a first spring arm coupled to the first wall and
20 a second spring arm coupled to the opposite wall, the first spring arm
being attached to the first wall essentially opposite to the second spring arm at the
opposite wall, the center body being movable with respect to the static portion
between a first position and a second position wherein movement of the center body
between the first and second position induces strain in the first spring arm and in the
25 second spring arm and corresponding compression of the first wall and the opposite
wall to avoid buckling of the first spring arm and the second spring arm.

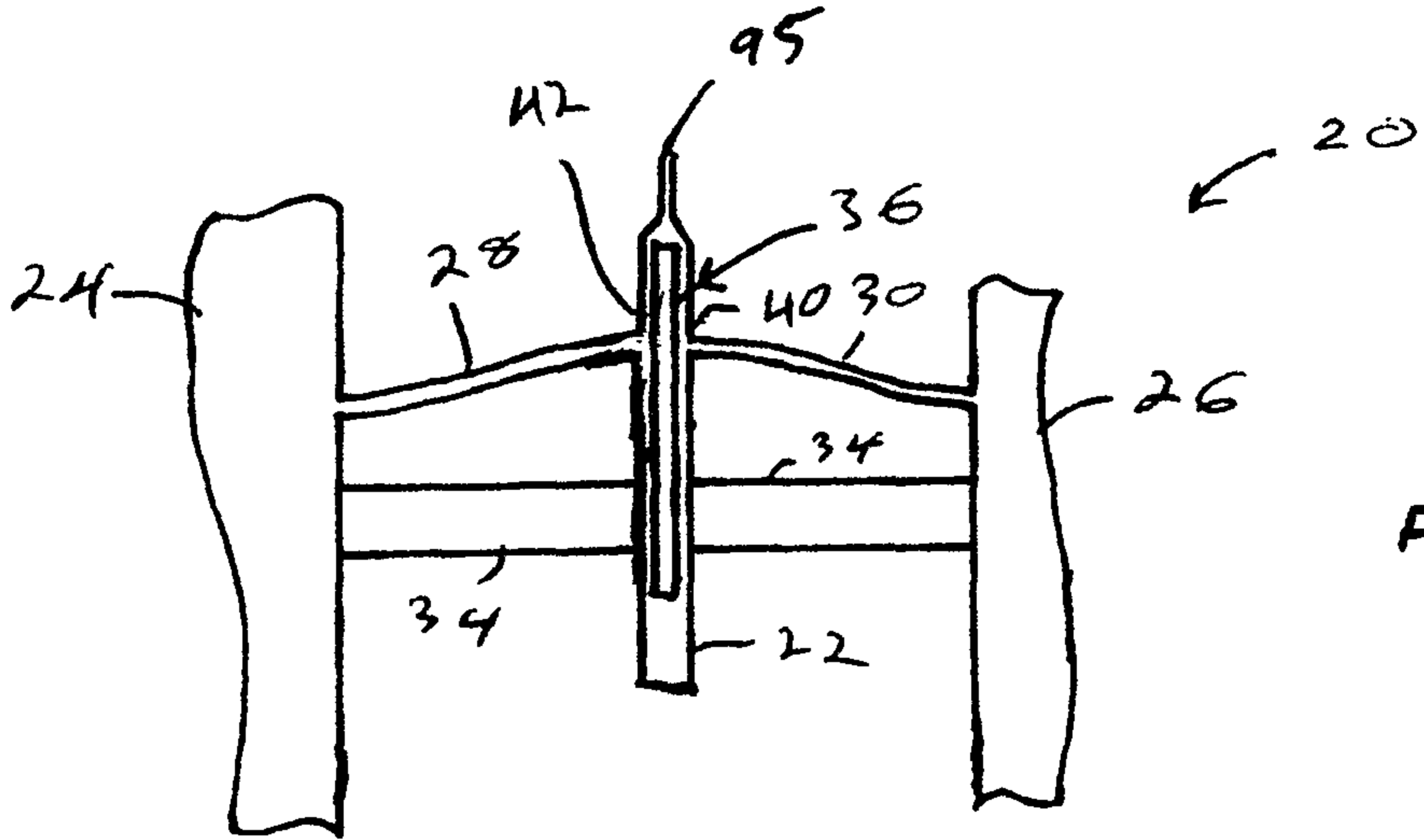

FIG. 1A.

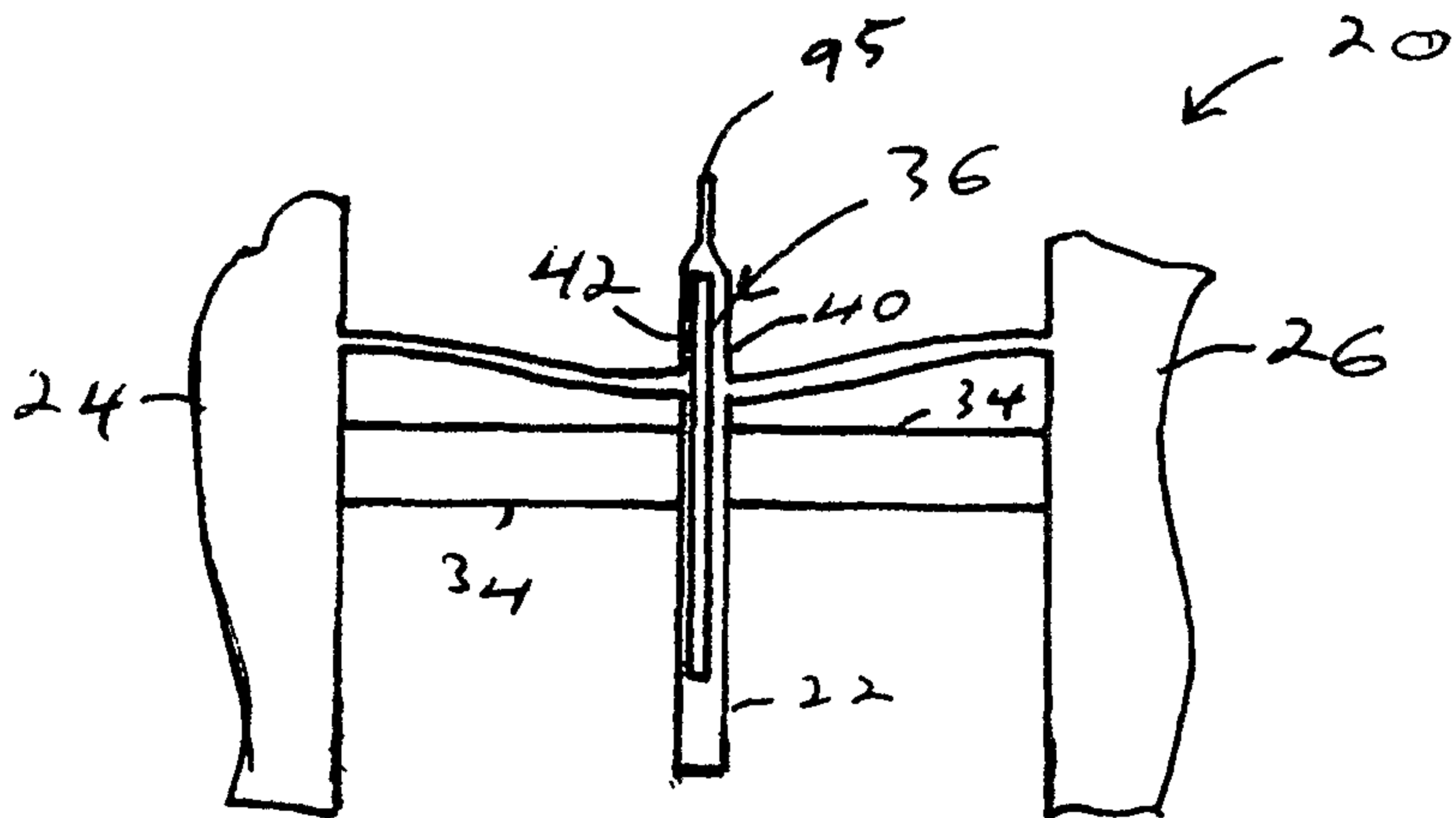

FIG. 1B

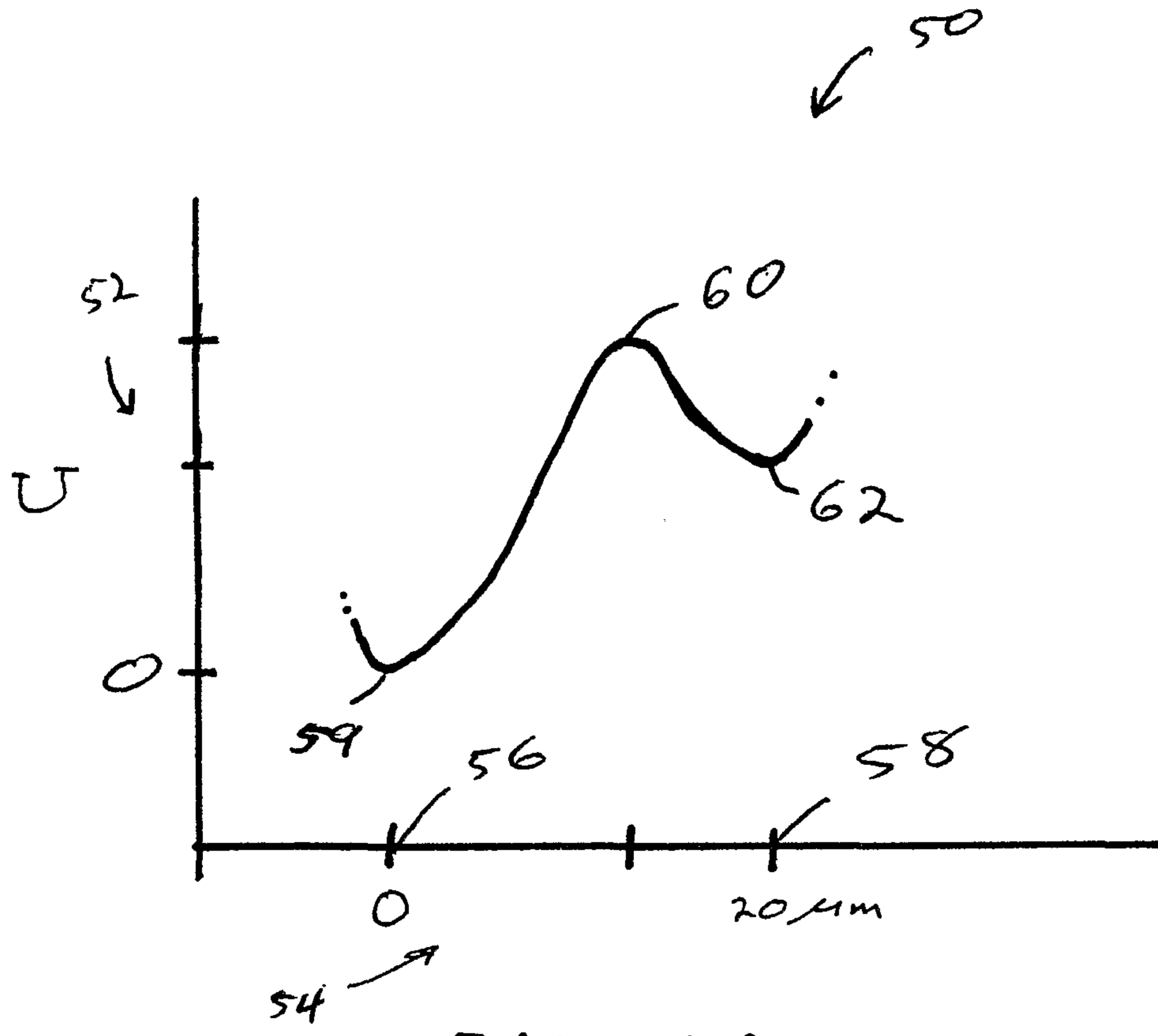

FIG. 1C.

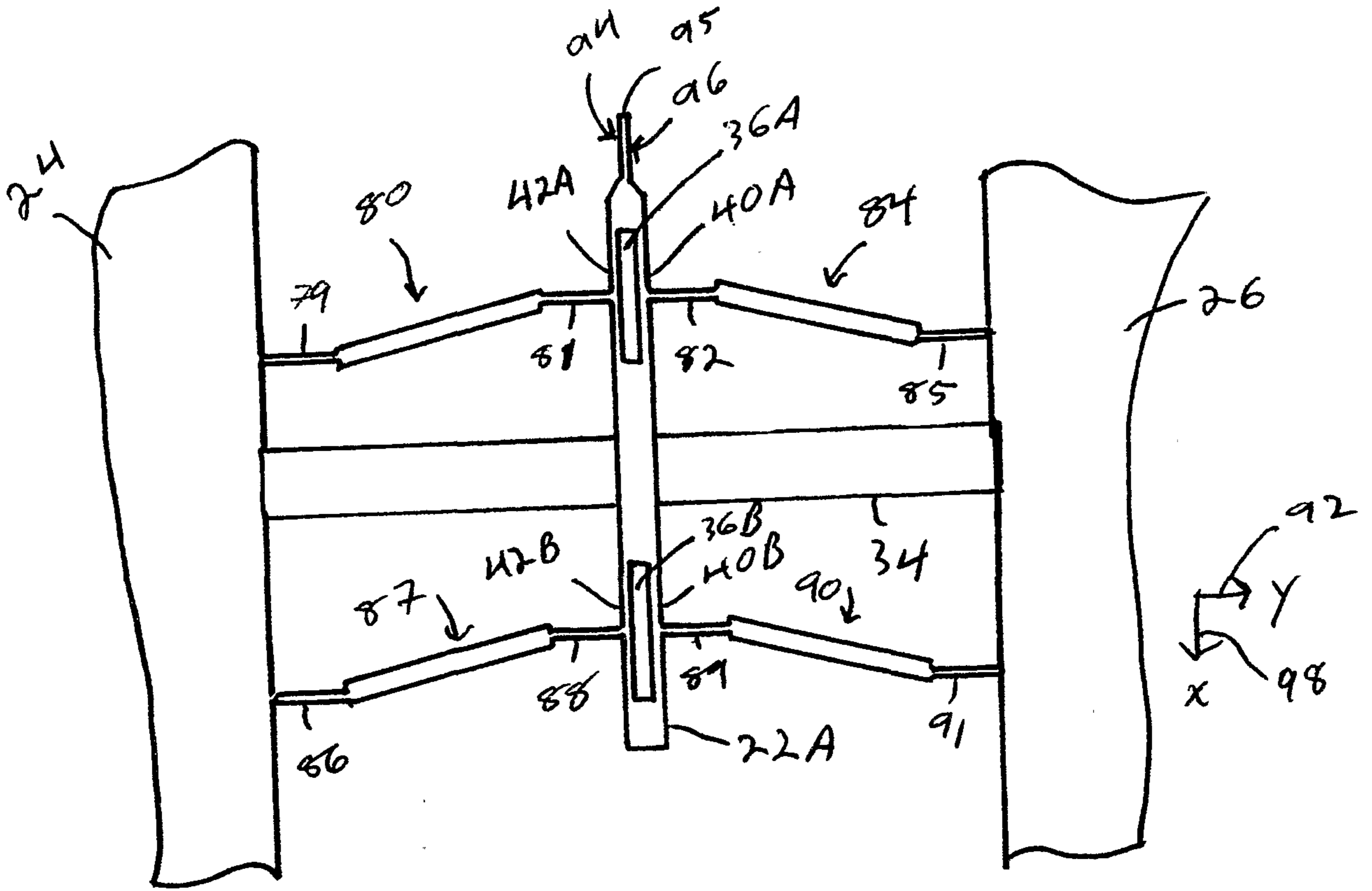

FIG. 2A.

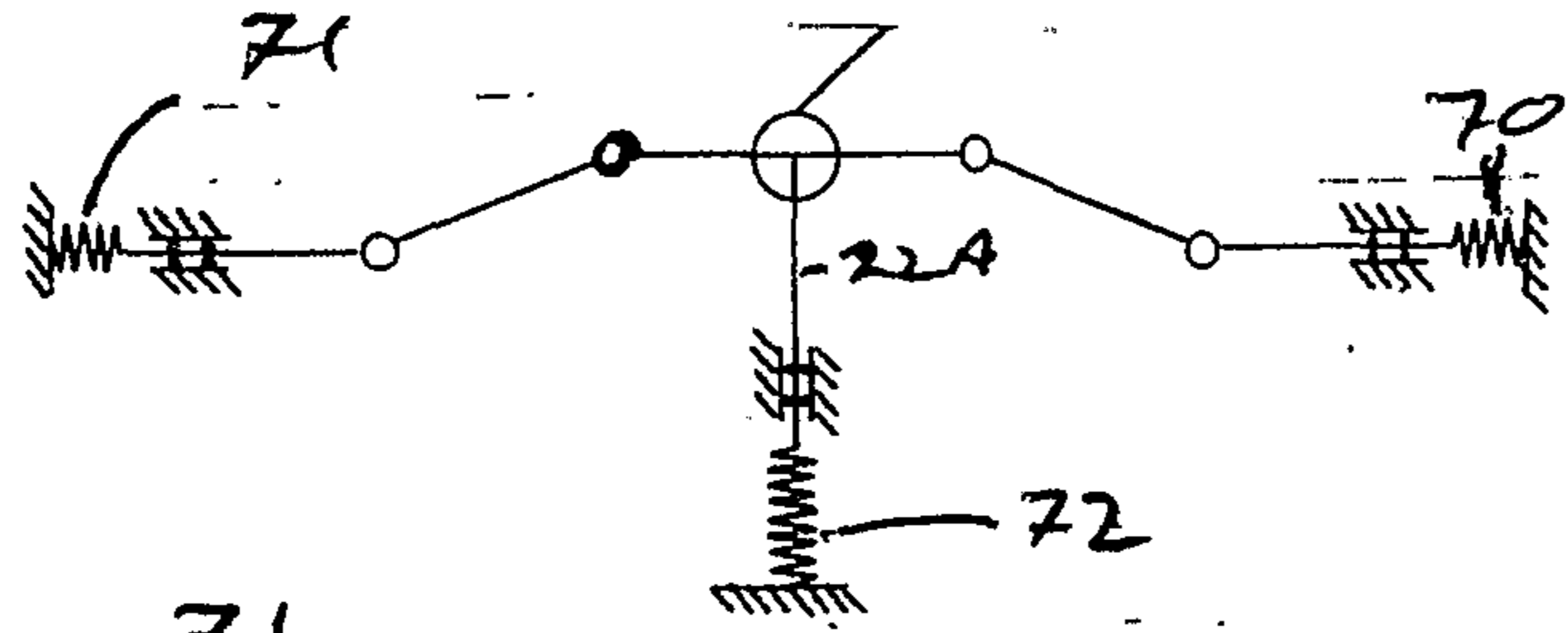

FIG. 2B.

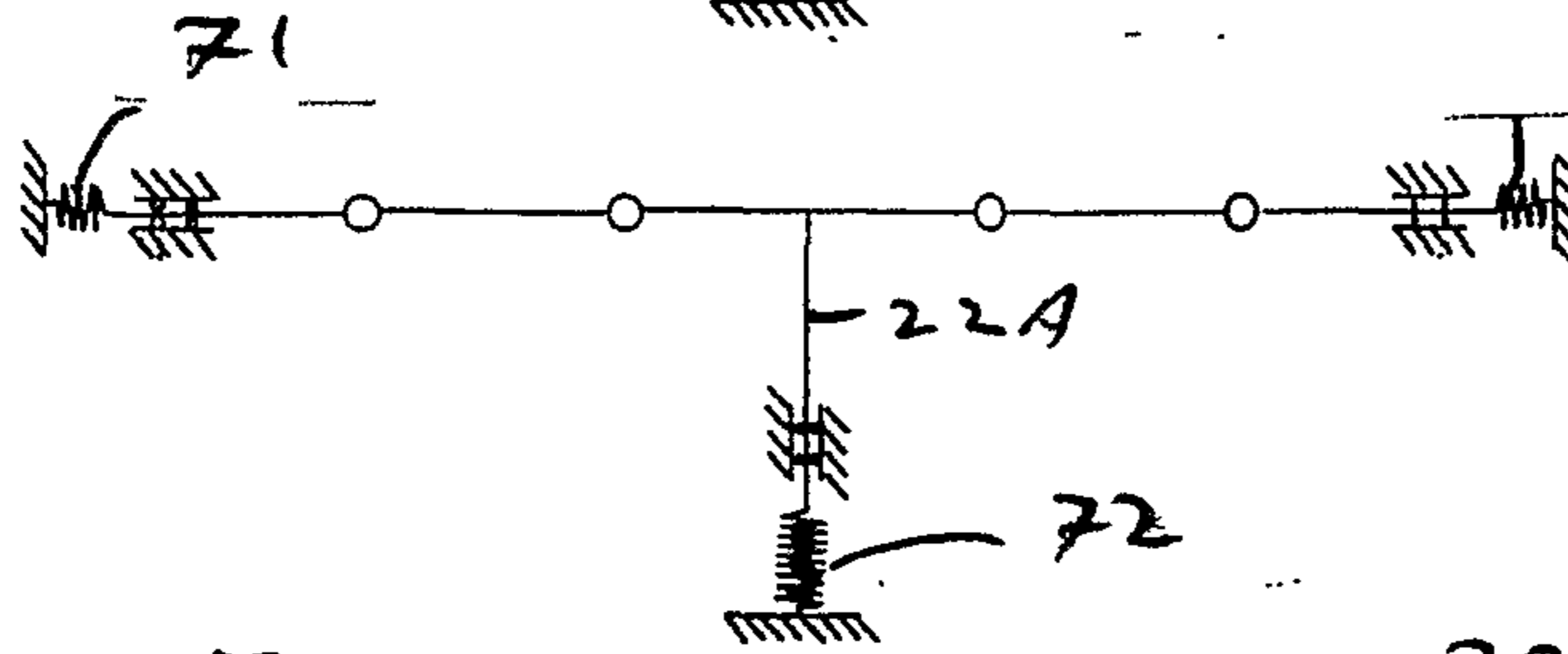

FIG. 2C.

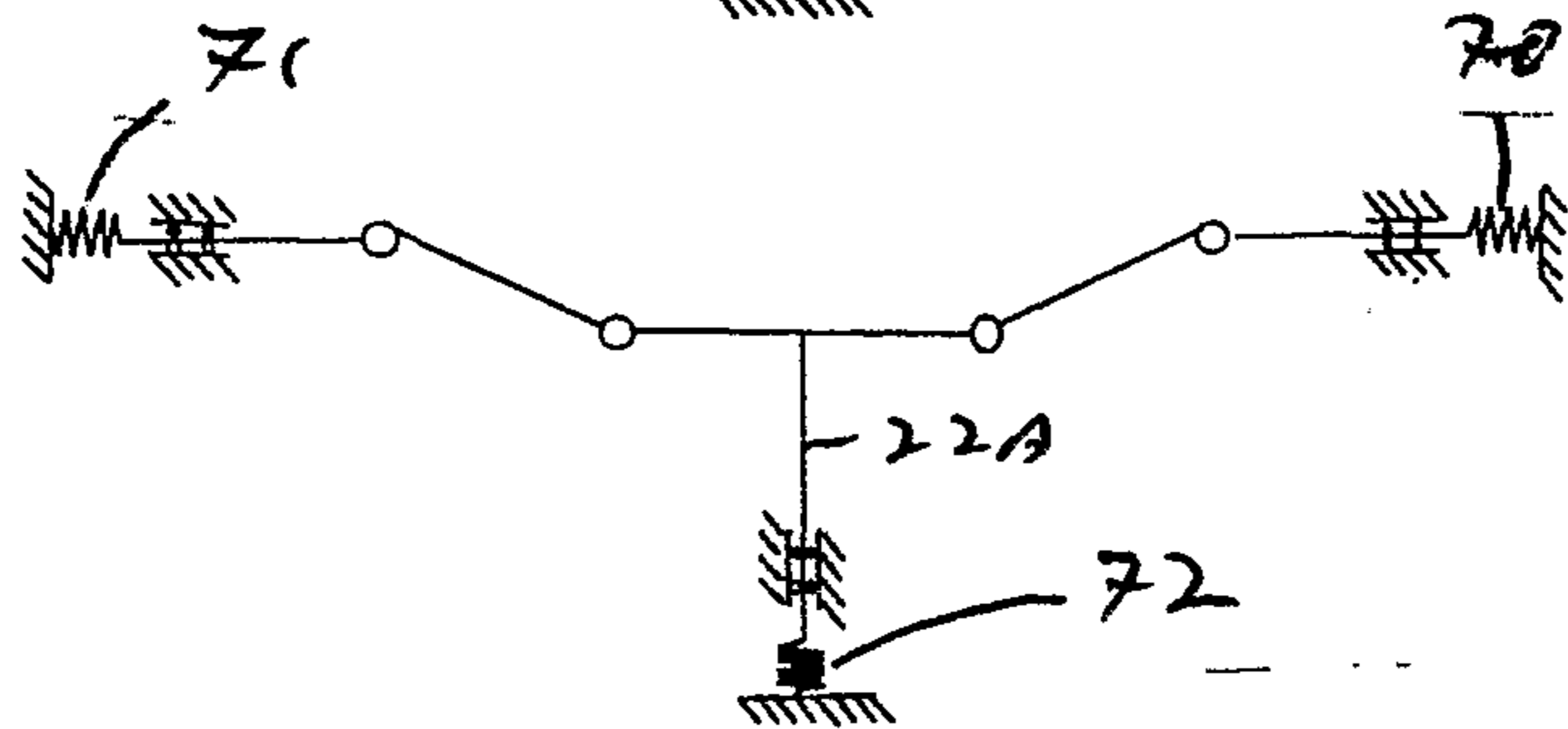

FIG. 2D

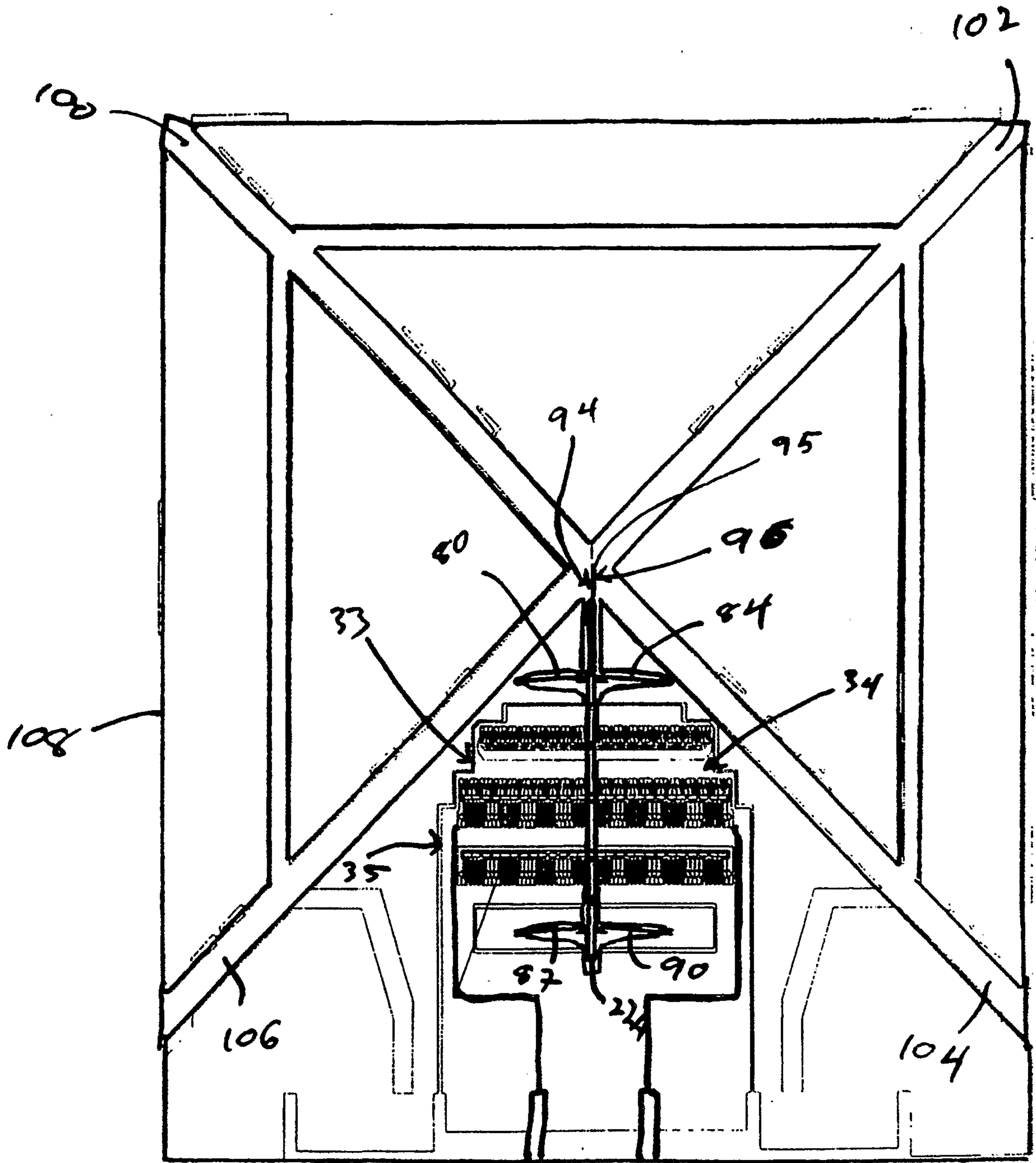

FIG. 3A.

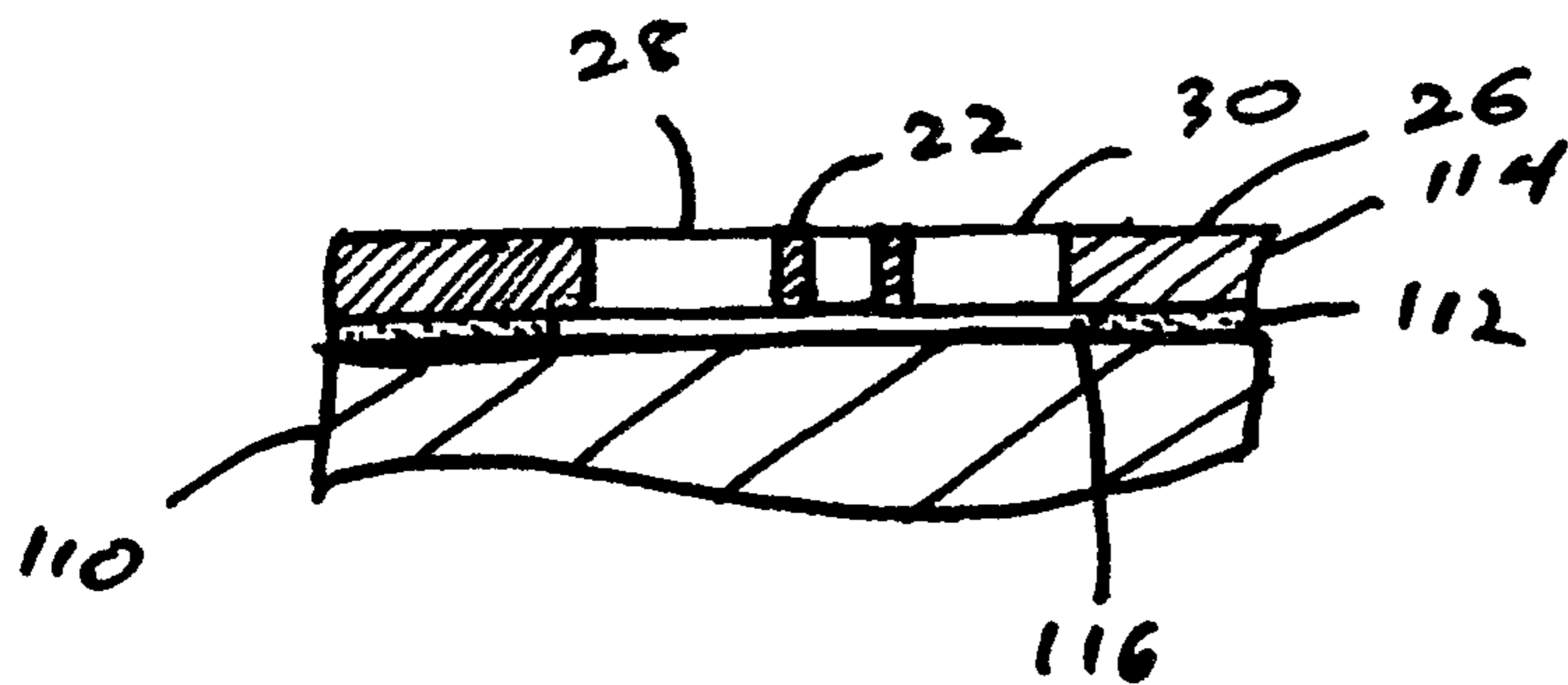
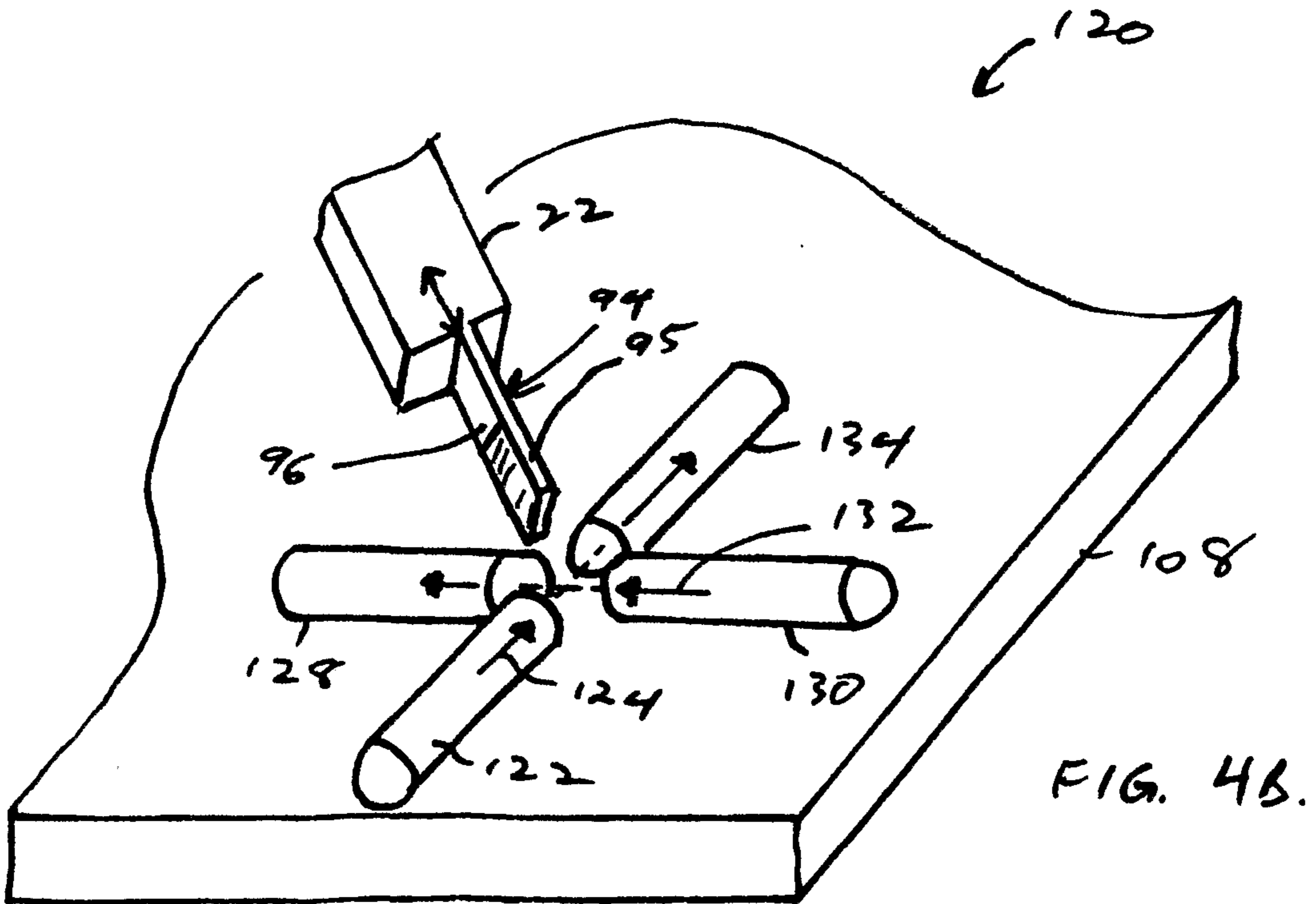
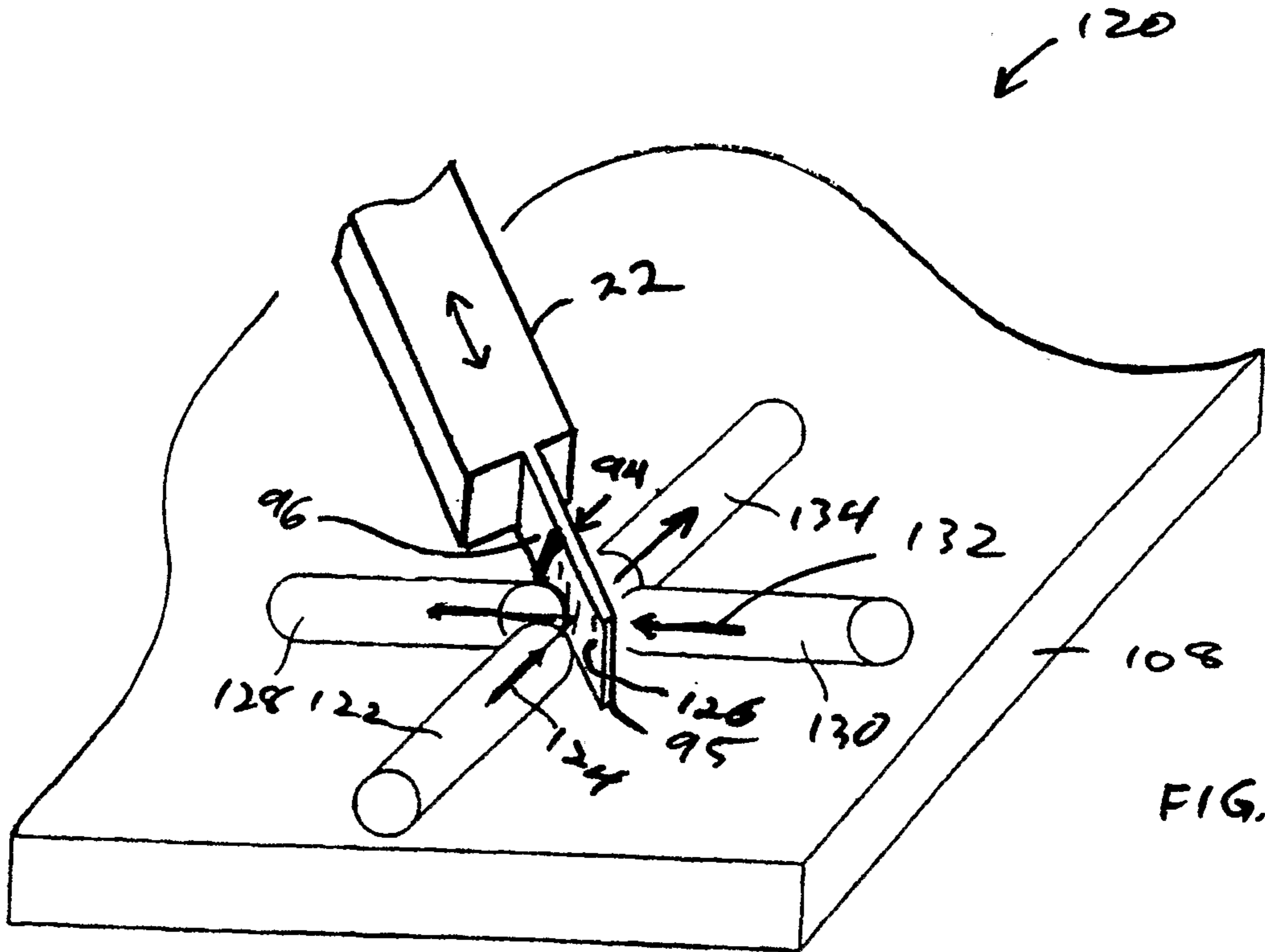

FIG. 3B.



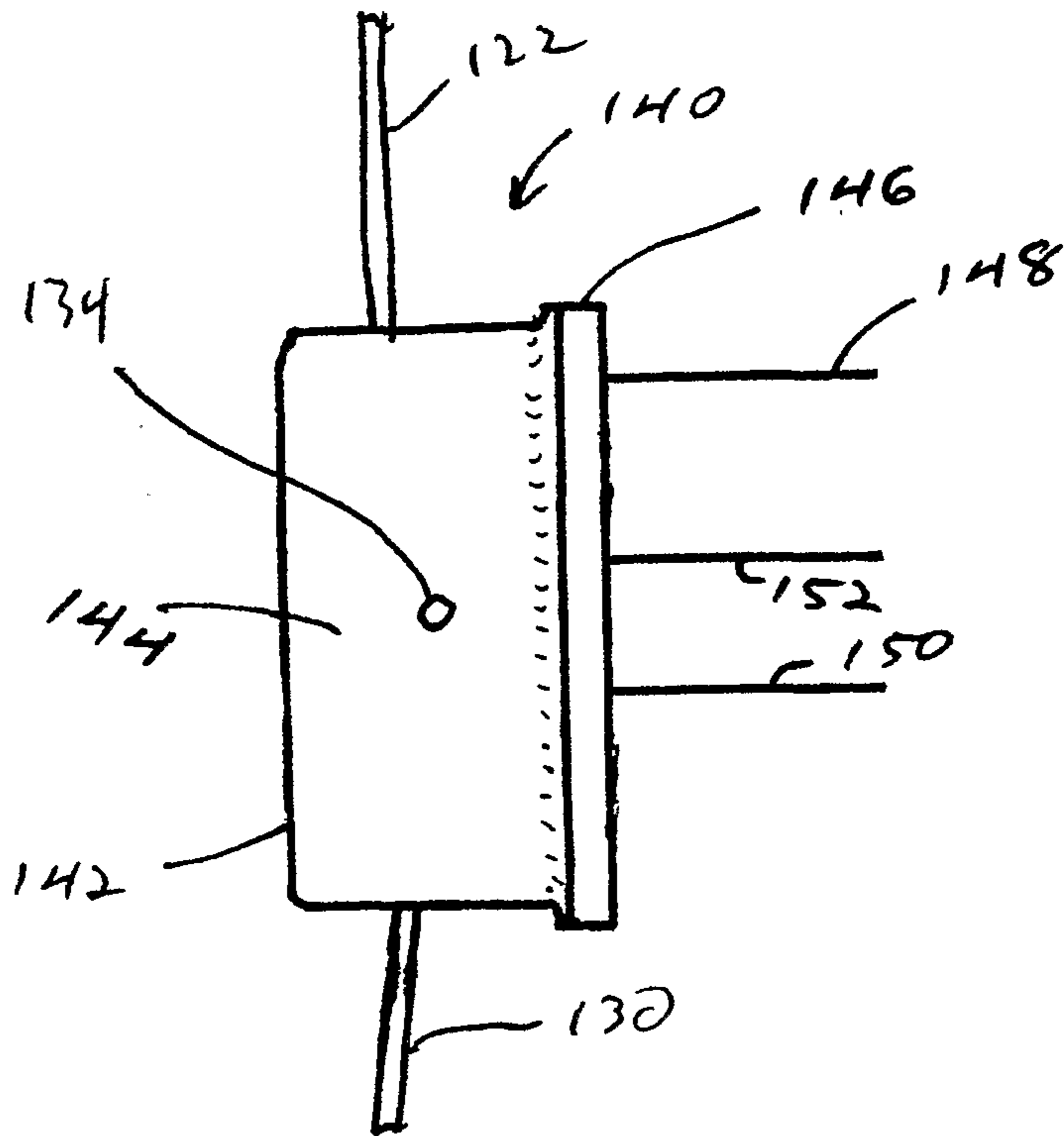

FIG. 4C.

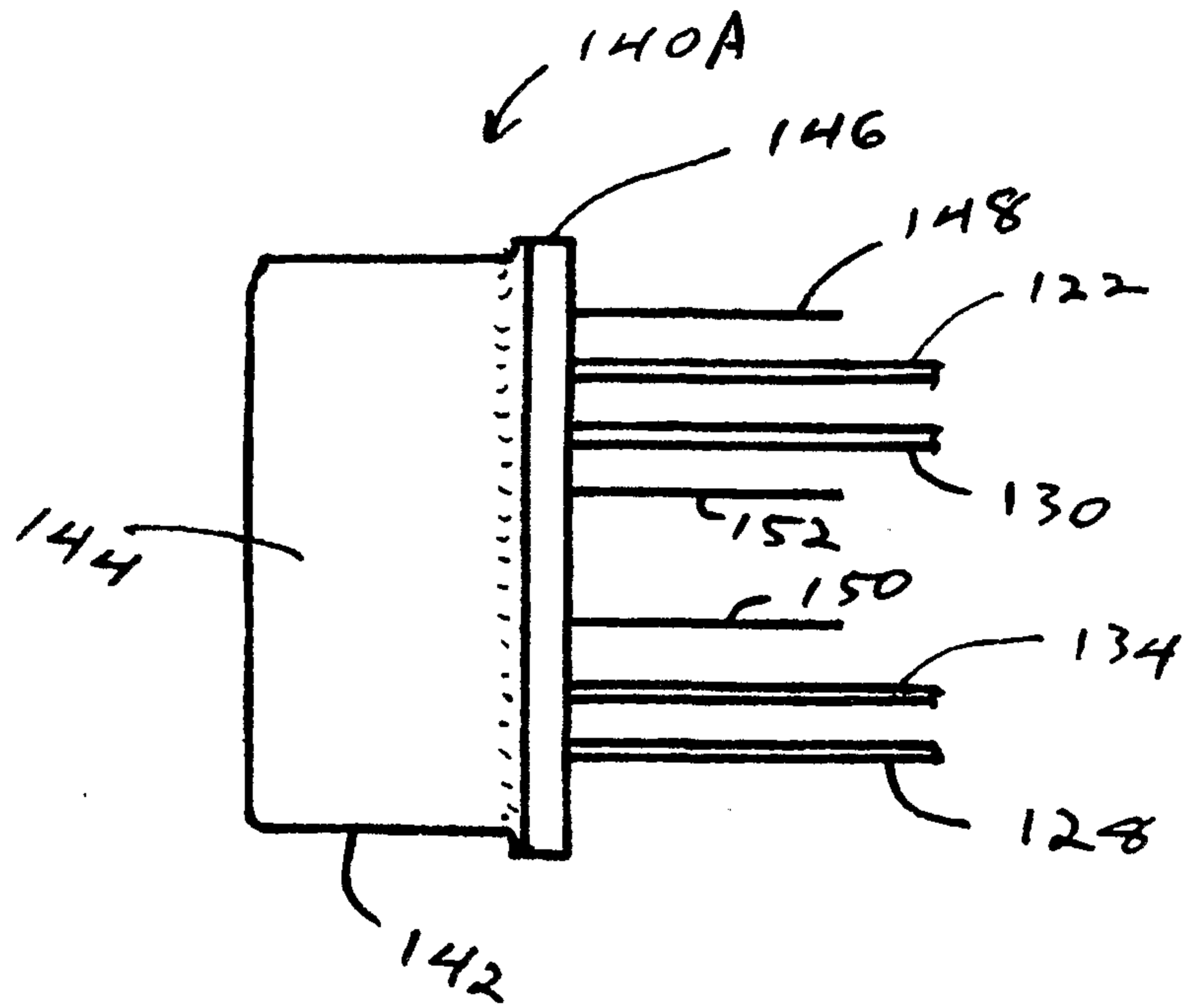
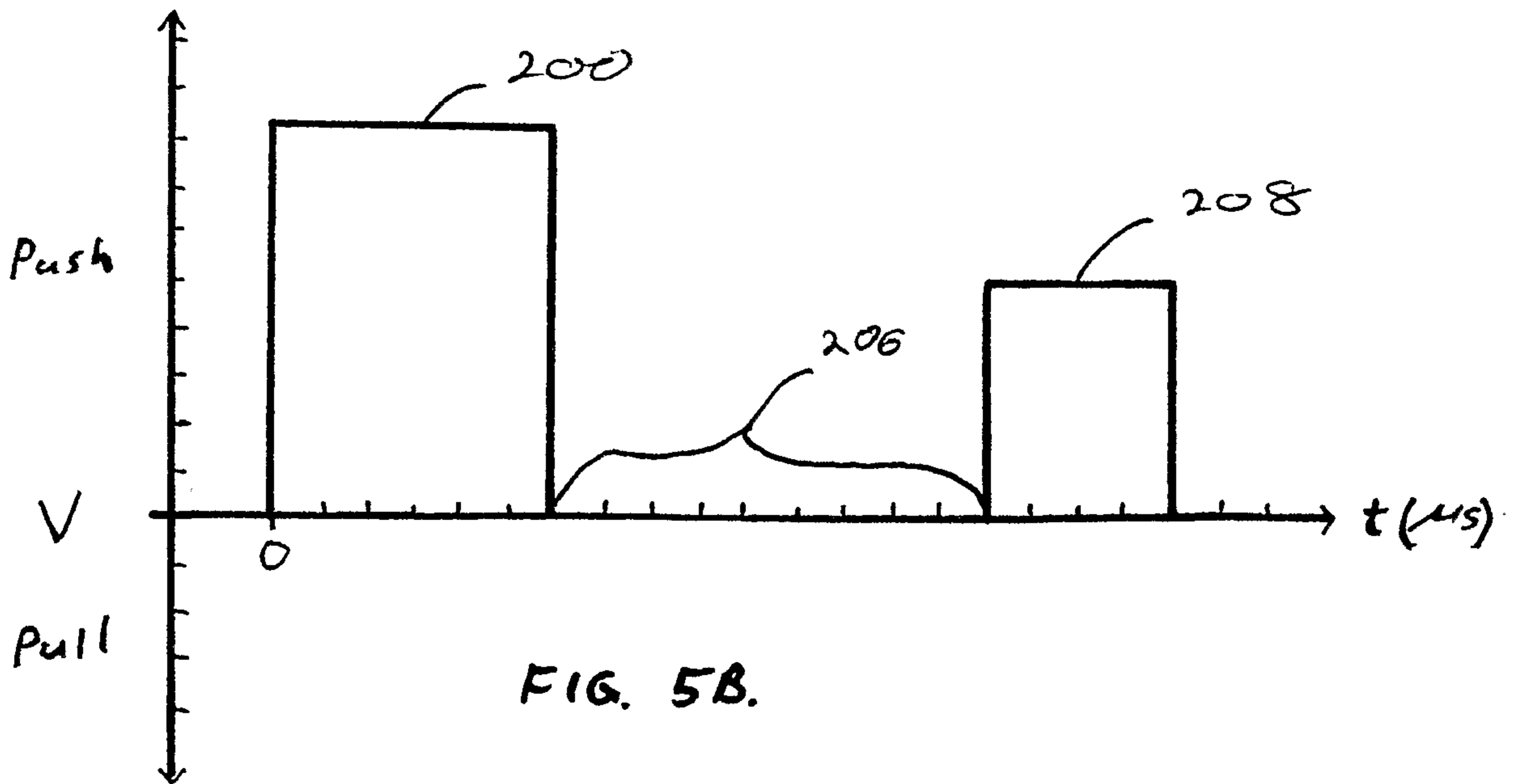
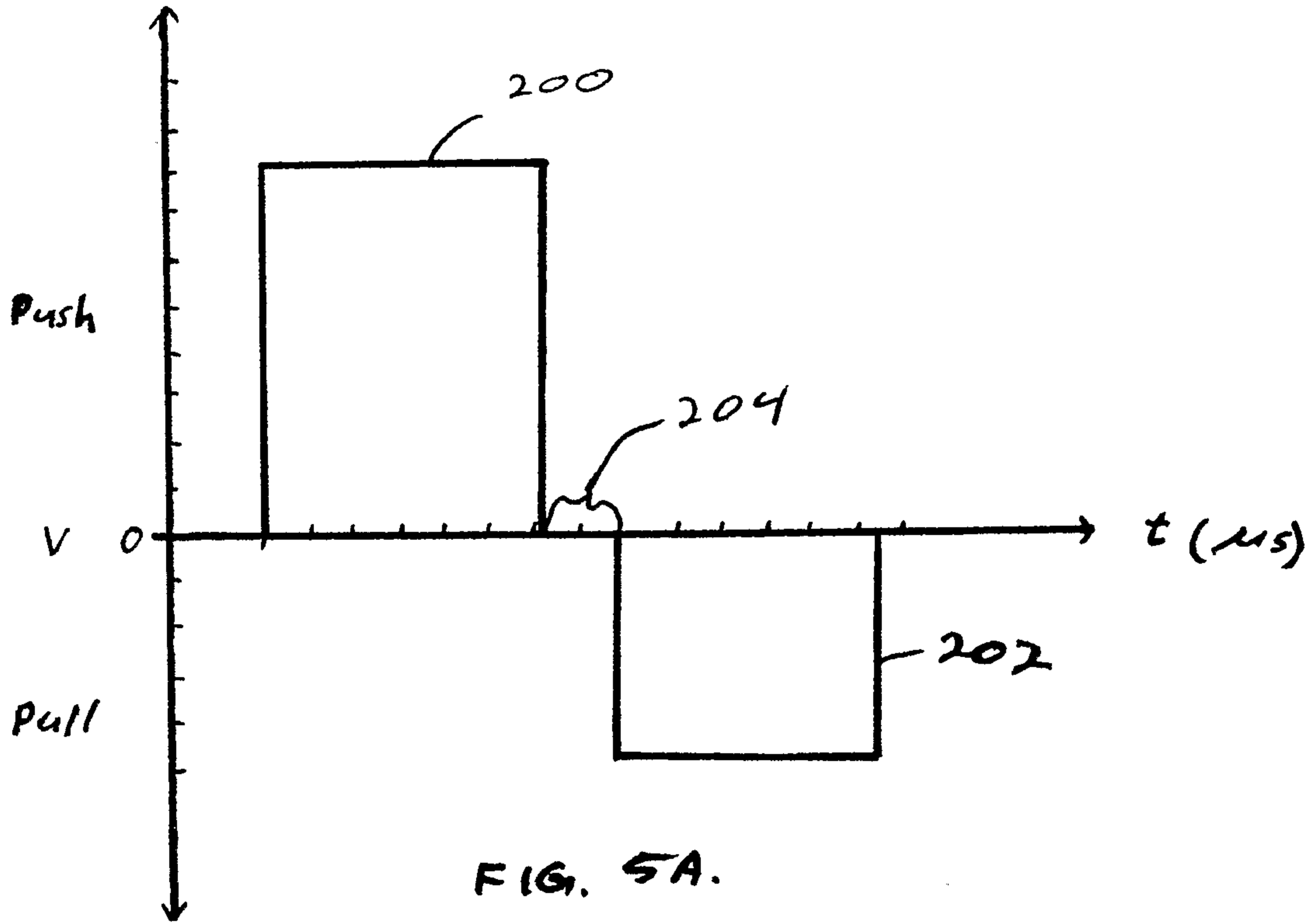

FIG. 4D.



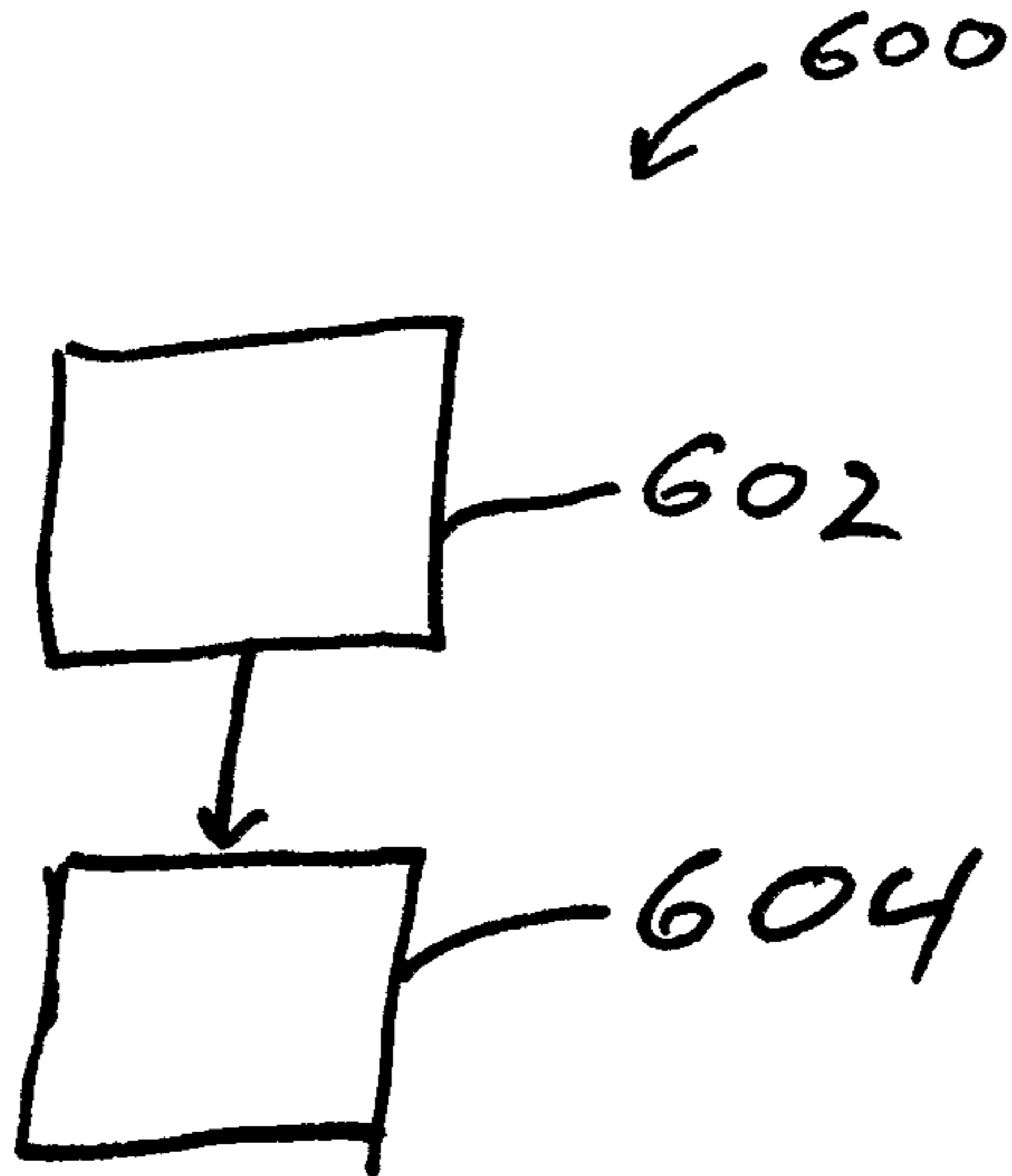

FIG. 6A.

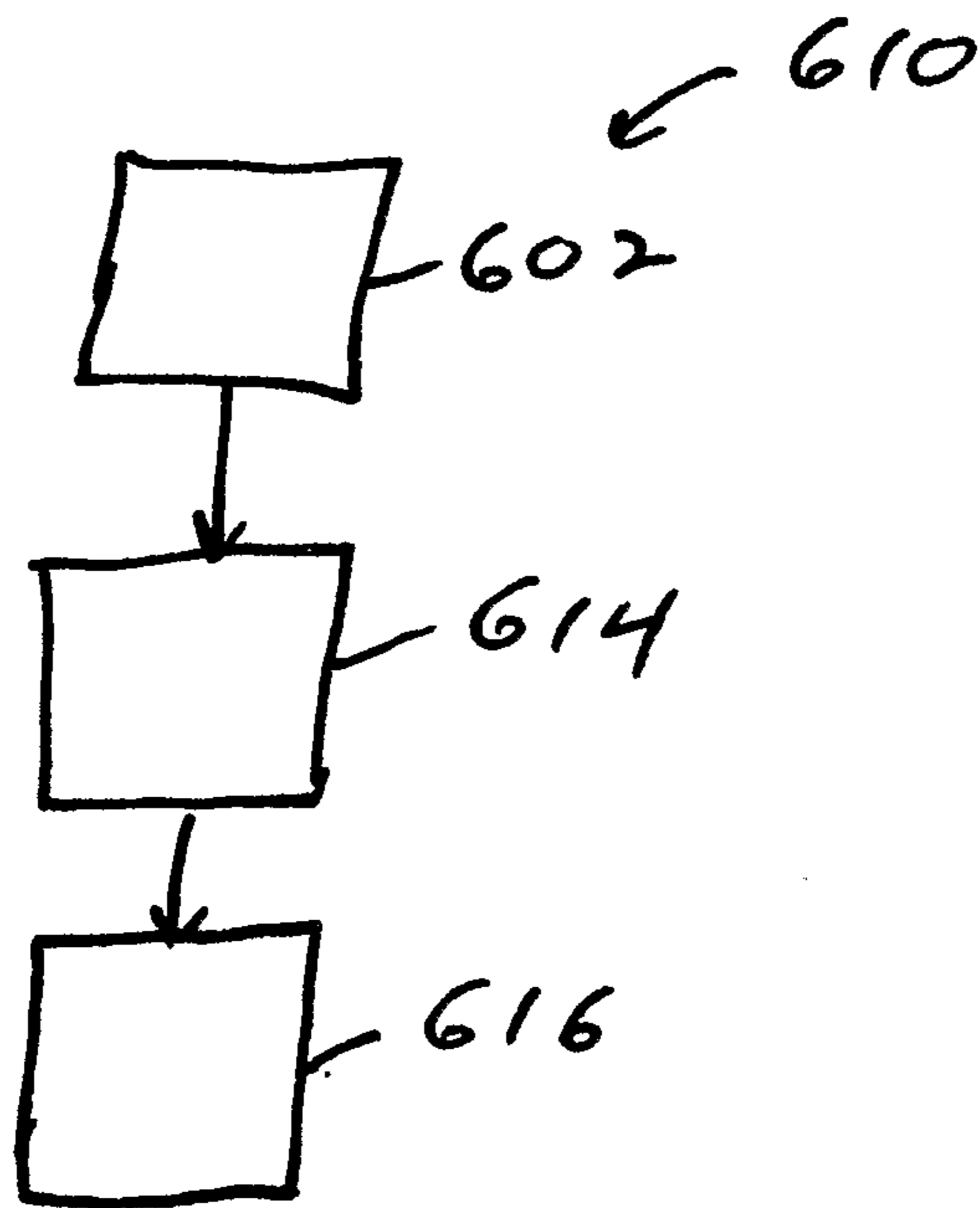

FIG. 6B.

