

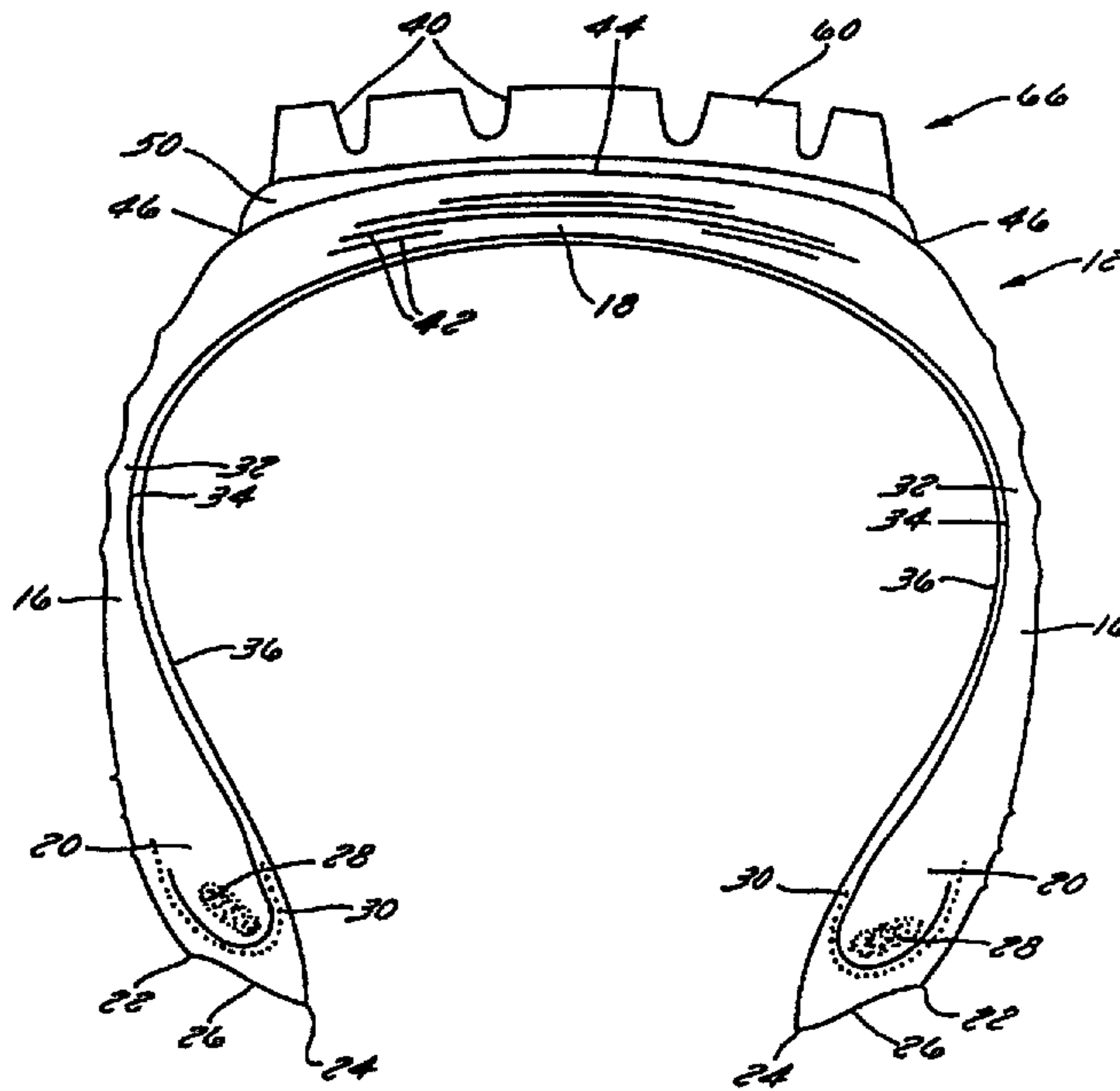

(86) Date de dépôt PCT/PCT Filing Date: 1996/03/08
 (87) Date publication PCT/PCT Publication Date: 1996/09/12
 (45) Date de délivrance/Issue Date: 2005/05/24
 (85) Entrée phase nationale/National Entry: 1997/08/22
 (86) N° demande PCT/PCT Application No.: US 1996/003126
 (87) N° publication PCT/PCT Publication No.: 1996/027493
 (30) Priorité/Priority: 1995/03/08 (08/399,070) US

(51) Cl.Int.⁶/Int.Cl.⁶ B29D 30/56, B60C 11/00
 (72) Inventeurs/Inventors:
 BENDER, DAVID L., US;
 BUNDSCHUH, JAMES E., JR., US;
 CARLSON, LAWRENCE, US;
 LOGSDEN, JOHNATHON LESLIE, US;
 MYERS, FLOYD S., US;
 SCHNEDLER, GARY W., US;
 SEILER, RONALD, US
 (73) Propriétaire/Owner:
 BANDAG LICENSING CORPORATION, US
 (74) Agent: GOWLING LAFLEUR HENDERSON LLP

(54) Titre : PNEUS RECHAPES ET METHODE DE RECHAPAGE SANS COLLE PULVERISEE
 (54) Title: RETREADED TIRES AND METHOD FOR MAKING THE SAME WITHOUT SPRAY CEMENT



(57) **Abrégé/Abstract:**

A retreaded tire assembly (66) and method for making the same is disclosed. The method and assembly provide for the application of new tread (60) to a buffed tire casing (12) with only a layer of cushion gum (50) disposed therebetween. The cushion gum (50) is applied directly to the buffed circumference (44) of a tire casing (12) without the use of conventional spray cement normally applied to the buffed surface (44) of the entire casing.



PCT

WORLD INTELLECTUAL PROPERTY ORGANIZATION
International Bureau

INTERNATIONAL APPLICATION PUBLISHED UNDER THE PATENT COOPERATION TREATY (PCT)

<p>(51) International Patent Classification ⁶ : B29D 30/56, B60C 11/00</p>	<p>A1</p>	<p>(11) International Publication Number: WO 96/27493 (43) International Publication Date: 12 September 1996 (12.09.96)</p>
--	------------------	--

<p>(21) International Application Number: PCT/US96/03126 (22) International Filing Date: 8 March 1996 (08.03.96) (30) Priority Data: 08/399,070 8 March 1995 (08.03.95) US (71) Applicant: BANDAG INCORPORATED [US/US]; 2905 North Highway 61, Muscatine, IA 52761 (US). (72) Inventors: BENDER, David, L.; 2767 Centerview Drive, Muscatine, IA 52761 (US). BUNDSCHUH, James, E., Jr.; 2628 Crystal Creek Court, Davenport, IA 52804 (US). CARLSON, Lawrence; 2903 Fairhaven, Muscatine, IA 52761 (US). LOGSDEN, Johnathon, Leslie; 502 Sycamore, Tipton, IA 52772 (US). MYERS, Floyd, S.; 2295 North Hilltop Drive, Muscatine, IA 52761 (US). SCHNEDLER, Gary, W.; P.O. Box 86, Letts, IA 52754 (US). SEILER, Ronald; 1538 West Acre Drive, Muscatine, IA 52761 (US). (74) Agents: MEYERS, Philip, G. et al.; Foley & Lardner, 35th floor, 777 East Wisconsin Avenue, Milwaukee, WI 53202 (US).</p>	<p>(81) Designated States: AM, AT, AU, BB, BG, BR, BY, CA, CH, CN, CZ, DE, DK, EE, ES, FI, GB, GE, HU, IS, JP, KE, KG, KP, KR, KZ, LK, LR, LT, LU, LV, MD, MG, MN, MW, MX, NO, NZ, PL, PT, RO, RU, SD, SE, SG, SI, SK, TJ, TM, TT, UA, UG, UZ, VN, ARIPO patent (KE, LS, MW, SD, SZ, UG), European patent (AT, BE, CH, DE, DK, ES, FI, FR, GB, GR, IE, IT, LU, MC, NL, PT, SE), OAPI patent (BF, BJ, CF, CG, CI, CM, GA, GN, ML, MR, NE, SN, TD, TG).</p> <p>Published <i>With international search report.</i></p>
---	--

(54) Title: RETREADED TIRES AND METHOD FOR MAKING THE SAME WITHOUT SPRAY CEMENT

(57) Abstract

A retreaded tire assembly (66) and method for making the same is disclosed. The method and assembly provide for the application of new tread (60) to a buffed tire casing (12) with only a layer of cushion gum (50) disposed therebetween. The cushion gum (50) is applied directly to the buffed circumference (44) of a tire casing (12) without the use of conventional spray cement normally applied to the buffed surface (44) of the entire casing.

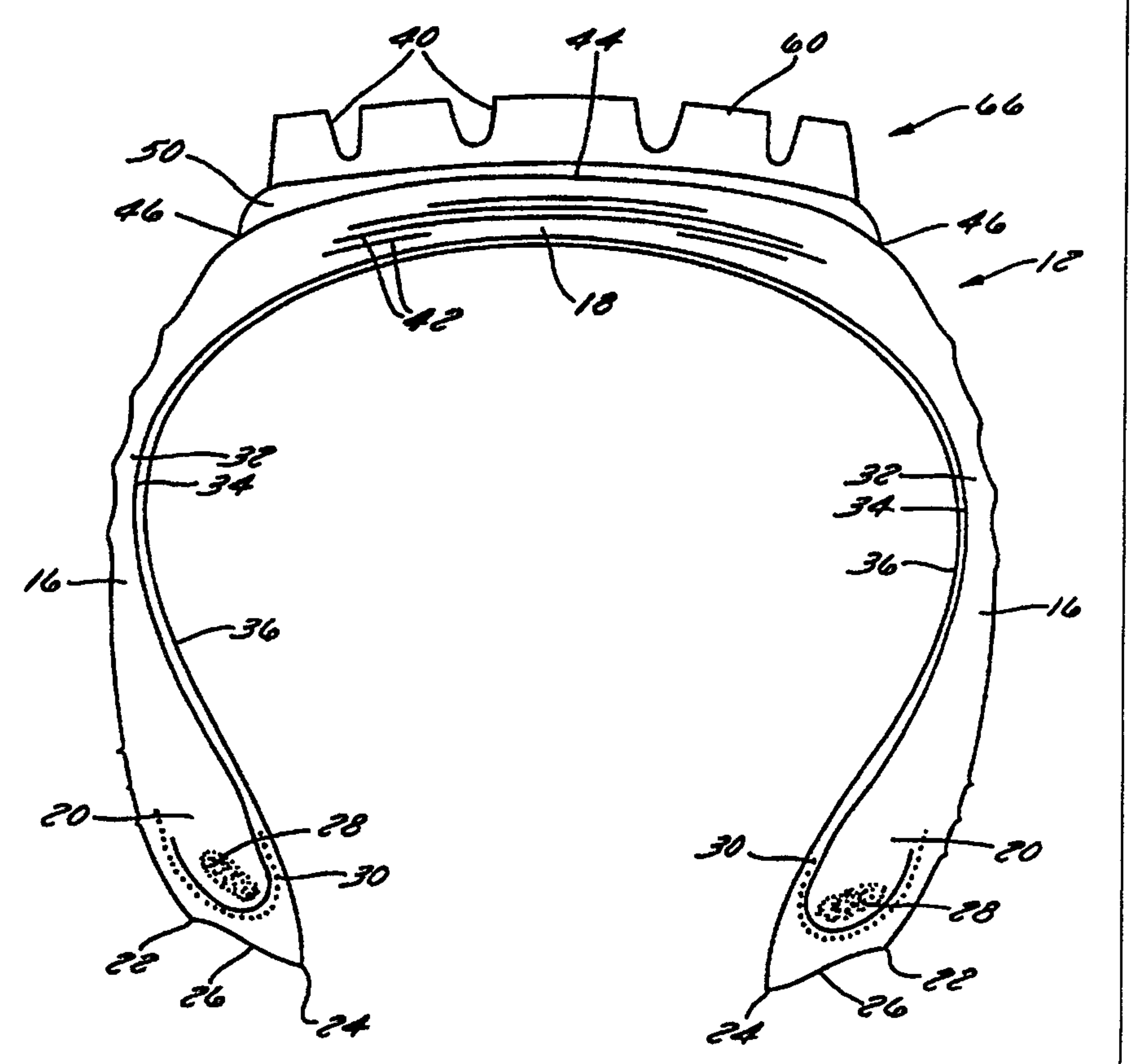

**RETREADED TIRES AND METHOD FOR
MAKING THE SAME WITHOUT SPRAY CEMENT**

TECHNICAL FIELD

5 This invention relates generally to a method for making retreaded tires and particularly to a method for making retreaded tires that eliminates the need for spray cement normally applied to the tire casing.

BACKGROUND OF THE INVENTION

10 Retreaded tires have been available for many years and provide an economical way to gain additional use out of a tire casing after the original tread has become worn. According to one conventional method of retreading, sometimes referred to as cold process retreading, the remaining tread on the used tire is removed by a special
15 buffing machine that grinds away the old tread and leaves a buffed surface to which a new layer of tread may be bonded.

Removal of the old tread from the tire casing provides a generally smooth treadless surface about the circumference of the tire casing. The tire casing may then
20 be examined for injuries, often called skives, which are filled with a repair gum. After completion of the skiving process, the buffed surface is sprayed with a tire cement that provides a tacky surface for application of bonding material and new tread. Then a layer of cushion gum is
25 applied to the back, i.e., the inside surface, of a new layer of tread. The cushion gum and tread are applied in

- 2 -

combination about the circumference of the tire casing to create a retreaded tire assembly ready for curing. The cushion gum forms the bonds between the tread and the tire casing during curing.

5 Following assembly of the tire casing, cement, cushion gum and tread, the overall retreaded tire assembly is placed within a flexible rubber envelope. An airtight seal is created between the envelope and the bead of the tire. The entire enveloped tire assembly is placed within a
10 curing chamber, and subjected to pressure and a raised temperature for a specific period of time. The combination of pressure, temperature and time chemically bonds the layer of cushion gum to both the tire casing and the new tire tread.

15 The above-described method of cold process retreading works well and provides high quality, retreaded tires. However, in certain applications it would be advantageous to eliminate the spray cement. This is particularly true in geographical areas where there is
20 increased regulation of the use of chemicals within spray cement. Generally, available spray cements include either heptane solvent or methyl chloroform. The heptane solvent has been found to contribute to smog formation, and methyl chloroform, although it does not cause smog, has tended to
25 be substantially more expensive than heptane solvent.

 Use of spray cement can also add to the cost of producing retreaded tires due to the product cost and equipment cost. For example, because cementing of the tire casing should only be done in a well ventilated spray booth,
30 retreading shops must purchase appropriate ventilation equipment. Elimination of the spray cement thus eliminates the need to purchase ventilated spray booths.

 A potential solution to smog problems associated with using heptane solvent is the installation of solvent
35 capture equipment at each retreading shop. However, this

- 3 -

solution is disadvantageous due to the cost of the equipment and the operational and maintenance costs. The present invention addresses the drawbacks associated with using spray cement during retreading of tires.

5

SUMMARY OF THE INVENTION

The present invention includes a method for retreading a tire that comprises the steps of removing the tire tread from a tire casing to present a buffed surface. Then, a layer of cushion gum is applied directly to the buffed surface without spraying cement over the buffed surface. A tread layer is wrapped about the layer of cushion gum, and finally, the tire is treated to form bonds between the casing and the layer of cushion gum and between the tread layer and the layer of cushion gum.

10

Another unique aspect of the invention is a retreaded tire assembly prepared for insertion into a pressurized heating chamber. The tire assembly includes a tire casing having a pair of side walls and a radially outer wall spanning the pair of side walls. The radially outer wall has a buffed surface disposed about the outer circumference of the tire casing. A layer of cushion gum is disposed directly against the buffed surface, and a tread layer is disposed against the cushion gum about the outside circumference of the cushion gum. After appropriate heat and pressure treatment, the tire casing, cushion gum and tread layer become bonded into an integral retreaded tire that may be used on an appropriate over-the-road vehicle.

15

20

25

BRIEF DESCRIPTION OF THE DRAWINGS

The invention will hereafter be described with reference to the accompanying drawings, wherein like reference numerals denote like elements, and:

30

Figure 1 is a cross-sectional view of an exemplary original tire;

- 4 -

Figure 2 is a cross-sectional view of the tire of Figure 1 after the tread layer has been removed from the tire casing;

5 Figure 3 is a schematic representation of the layer of cushion gum and the new tread layer being applied to a tire casing;

Figure 4 is a cross-sectional view of the tire casing illustrated in Figure 2 with the addition of the layer of cushion gum and the new tread layer; and

10 Figure 5 is a perspective cross-sectional view of an alternate embodiment of a retreaded tire according to the invention.

DETAILED DESCRIPTION OF THE PREFERRED EMBODIMENT

Referring generally to Figure 1, an original tire 15 10 is shown as having a tire casing 12 from which extends a tire tread 14. The illustrated tire 10 is a radial tire; however, the invention applies equally to other types of tires, such as bias ply tires.

20 More particularly, tire 10 includes a pair of side walls 16 bounded by a generally radially outward wall 18 that spans side walls 16. Each side wall 16 extends radially inward from outer wall 18 and terminates in a bead area 20 designed for mounting on the tire rim (not shown). Bead area 20 may be designed in a variety of configurations 25 depending on, for example, tire type, tire size or rim configuration. In the illustrated embodiment, each bead area 20 includes a bead heel 22, a bead toe 24, and a bead sole 26. Each bead area 20 may also include a bead bundle 28 and a chafer ply 30. Both bead bundle 28 and chafer ply 30 30 may include, for example, metal strands or wires to improve the strength of bead area 20.

Side walls 16 may also include multiple layers, such as a rubber layer 32, a radial ply 34 and an inner liner 36 which cooperate to provide a strong but flexible

- 5 -

side wall. Side walls 16 are joined to radially outward wall 18 and tread 14 through a pair of shoulder areas 38. Shoulder areas 38 extend towards tire tread 14 which, in turn, is disposed radially outwardly from wall 18 of tire casing 12. Tire tread 14 may include a plurality of grooves 40 designed to channel water and provide added traction during certain road conditions. Additionally, outer wall 18 may be strengthened by a plurality of belts or cords 42 extending circumferentially about tire 10 within wall 18 (see Figures 2 and 5).

After tire tread 14 wears beyond a certain limit, tire 10 must either be discarded or retreaded before it should be used on the vehicle for which it was designed. In cold process retreading, the remaining tire tread 14 is removed from tire casing 12 by a buffing machine, such as the Model 8110 buffing machine manufactured by Bandag, Incorporated of Muscatine, Iowa. During the buffing operation, the original tire tread 14 is ground away from tire casing 12, leaving a buffed surface 44 as illustrated in Figure 2. Buffed surface 44 extends circumferentially about tire casing 12 and also extends transversely across the outside of outer radial wall 18 until it terminates at buffed shoulder areas 46.

Following removal of the used tread layer, a process called skiving and filling is performed on tire casing 12. Skiving is the removal of damaged material from a tire prior to making a repair. Often, the tire casing 12 accumulates holes, nicks or tears due to stones or other sharp objects the tire comes in contact with during use. The injured or damaged area is first ground smooth by an appropriate grinding tool and then filled with repair gum, such as Bandag extruder repair rope or repair gum or some other suitable material. It is necessary to fill the injured areas to the level of buffed surface 44 to avoid air pockets between buffed surface 44 and the later applied

- 6 -

tread layer. Trapped air can have negative effects on the longevity of a typical retreaded tire. Following the skiving and filling operation, a building step occurs in which a layer of cushion gum and a new tread layer are wrapped about the circumference of tire casing 12 along buffed surface 44.

As illustrated best in Figure 3, a building machine 48 (shown schematically), such as the Bandag 5110 semiautomatic builder manufactured by Bandag, Incorporated, may be used to apply a layer of cushion gum 50, such as HD30 cushion gum manufactured by Bandag, Incorporated. Although the layer of cushion gum 50 could be applied to tire casing 12 in a variety of ways, the schematic representation of Figure 3 shows a roll of the cushion gum 52 rotatably mounted on building machine 48. The layer of cushion gum 50 moves about a tensioning roller 54 prior to being wrapped circumferentially around buffed surface 44.

Preferably, cushion gum layer 50 is covered by a bottom plastic sheet 56, e.g. a poly sheet, and a similar top plastic sheet 58. As illustrated, bottom sheet 56 is peeled away from cushion gum layer 50 shortly before the cushion gum is wrapped about tire casing 12 along buffed surface 44. Bottom plastic sheet 56 may then be wrapped about tensioning roller 54 as shown in Figure 3.

Cushion gum layer 50 is preferably applied to buffed surface 44 within eight hours of buffing. Additionally, the application has been found to work best when the layer of cushion gum 50 is applied under tension in the circumferential direction. Depending on the application, it may be desirable to slightly stretch the cushion gum layer 50 to achieve better adherence to buffed surface 44. Cushion gum layer 50 is cut transversely and the cut edge is spliced with the leading edge so there is no gap between the beginning and the end of cushion gum layer

- 7 -

50. Any overlap between the leading edge and the trailing cut edge is preferably limited to one-eighth inch or less.

5 After cushion gum layer 50 is applied to tire casing 12, layer 50 is stitched, or in other words pressed, against buffed surface 44 to drive out any air trapped between the cushion layer and buffed surface 44. Following stitching, the top layer of plastic 58 is removed from cushion gum layer 50 to permit a new tread layer 60 to be applied over the cushion gum. The stitching step also helps prevent the cushion from lifting away from buffed surface 44 when plastic layer 58 is removed and tread layer 60 is applied.

15 Preferably, tread layer 60 is also applied with the assistance of building machine 48, although there are a variety of ways to wrap tread layer 60 about the circumference of tire casing 12. When using building machine 48, a tread roll 62 is rotatably mounted thereon, and tread layer 60 is guided onto tire casing 12 against cushion gum layer 50 by guide rollers 64.

20 Tire casing 12 is rotated on building machine 48 until a sufficient length of tread layer 60 is unraveled from tread roll 62 to extend about the circumference of tire casing 12. Tread layer 60 is then cut generally transversely to the circumferential direction, and the cut end is butted up against the leading edge of tread layer 60 to form a splice. The tread layer splice is often held together by a plurality of staples (not shown). It is also preferred that the spliced area of cushion gum layer 50 and the spliced area of tread layer 60 be disposed at different points along buffed surface 44.

30 Although the application of cushion gum layer 50 and tread layer 60 to a tire casing 12 by building machine 48 has been generally known in the industry for many years, the unique aspects of this inventive method of retreading allows the omission of a previous step, namely the

35

- 8 -

application of spray cement to buffed surface 44. Previously, spray cement would be initially applied to buffed surface 44. Then, cushion gum layer 50 would be applied to the inside or lower surface of tread layer 60.

5 The combination of cushion gum layer 50 and tread layer 60 would be wrapped about cement covered buffed surface 44 and spliced together.

The present method permits the elimination of the spray cement which overcomes certain disadvantages described
10 in the background of the invention section above. By first stretching the layer of cushion gum about the circumference of tire casing 12, stitching the cushion gum and then applying tread layer 60 over the combined tire casing 12 and cushion gum layer 50, the necessity of using spray cement
15 has been eliminated. It has been found that retreaded tires made according to the new method have very desirable characteristics without requiring an extra cementing step.

After application of cushion gum layer 50 and tread layer 60, a retreaded tire assembly 66 is created and
20 ready for curing under appropriate heat and pressure conditions. A cross section of the retreaded tire assembly 66 is illustrated best in Figure 4. After assembly, the overall tire assembly is inserted into a rubberized curing envelope, such as the appropriate Bandag, Incorporated curing
25 envelope designed for the particular tire type and size being retreaded.

The retreaded tire assembly 66 is sealed within the curing envelope and placed within a curing chamber, such as the Model 4130 or 4120 curing chamber sold by Bandag,
30 Incorporated. Pressure and heat are applied to the retreaded tire assembly 66 within the curing chamber. The amount of time necessary to cure a given retreaded tire may vary depending on the size of the tire and the materials used. However, the time must be long enough to create
35 sufficient bonding between the tire casing 12 and cushion

- 9 -

gum layer 50 and between the tread layer 60 and cushion gum layer 50. Generally, the bonding results from vulcanization between the tire casing, cushion gum layer and tread layer. The times, pressures and temperatures within the curing chamber would be known by one of ordinary skill in the art. However, exemplary parameters during curing within the curing chamber are temperature: approximately 210° F; pressure: approximately 85 psi; and time: approximately three and one half hours. The above listed temperature, pressure and time parameters are only provided as examples, and are not meant to limit the scope of the invention. As stated previously, the time within the curing chamber may vary depending on the tire size and tire materials. Additionally, other combinations of temperature and pressure can potentially provide satisfactory results. After curing, the retreaded tire may undergo certain minor trimming operations, but otherwise is ready for use on a vehicle.

Another embodiment of retreaded tire assembly 66 is illustrated in Figure 5. The process used for this type of retreaded tire is the same as that described above, except for the addition of a pair of shoulder strips 68 of cushion gum that are added to accommodate arched outer flanges 70 of a slightly different tread layer 72. In this embodiment, tread layer 72 extends about the circumference of tire casing 12 as described above, but the arched outer flanges 70 curve in the transverse direction generally about shoulder areas 46 of tire casing 12. Accordingly, additional cushion gum must be added in the form of shoulder strips that run generally along each shoulder area 46 of tire casing 12 and beneath flanges 70.

Thus, after cushion gum layer 50 is applied to buffed surface 44, and stitched thereto, the top layer of plastic 58 is removed and shoulder strips 68 are applied along shoulder areas 46. The tread layer 72 including its arched outer flanges 70 is applied over cushion gum layer 50

- 10 -

and shoulder strips 68, measured, cut, and spliced similarly to that described above.

The various parameters involved in cementless retreading of tires may vary depending on the overall design of the tire being retreaded and the composition of the retreading materials. However, in general, it is preferred that the temperature of both tire casing 12 and cushion gum layer 50 be at least 65 degrees Fahrenheit when the cushion gum layer is applied to buffed surface 44. Additionally, the cushion should be applied to the uncemented casing within eight hours of buffing or, if the buffed casing is covered with poly, the cushion application should be within 72 hours of buffing. Furthermore, to ensure a high quality retreaded tire, it is preferred that the centerline of cushion layer 50 be aligned with the center line of the buffed casing within plus or minus one eighth inch. When applying the flat style tread illustrated in Figure 4, there should be at least one eighth inch of cushion layer 50 extending transversely past the base of the tread on each side of tread layer 60. Similarly, cushion layer 50 should be applied with enough tension to facilitate conformation to the buffed surface 44, but the tension should not cause the width of cushion layer 50 to be reduced by more than one eighth inch. Generally, the length of cushion layer 50 is approximately 2-8 inches shorter than the circumference of buffed surface 44.

It will be understood that the foregoing description is of the preferred exemplary embodiment of this invention and that the invention is not limited to the specific form shown. For example, the invention is directed to a tire assembly and a method for retreading tires that does not require the use of spray cement, and therefore a wide variety of equipment may be used to apply the layers of cushion gum and tread to the tire casing. Additionally, the invention encompasses a broad variety of tires, materials,

- 11 -

and tread designs that may be assembled according to the invention. The methods of preparing the tire casing and curing the retreaded tire assembly may vary substantially due to differences in materials, equipment and techniques for creating retreaded tires. These and other modifications may be made in the design and arrangement of the elements without departing from the scope of the invention as expressed in the appended claims.

- 12 -

CLAIMS

What is claimed is:

1. A method for retreading a tire, comprising the steps of:
 - removing tire tread from a tire casing to present a buffed tire casing having a buffed surface;
 - applying a layer of cushion gum directly to the buffed surface by stretching the layer of cushion gum between two to eight inches circumferentially about the buffed surface;
 - wrapping a tread layer about the layer of cushion gum;
 - inserting the buffed tire casing, layer of cushion gum and tread layer into a curing envelope; and
 - treating the tire to form bonds between the casing and the layer of cushion gum and between the tread layer and the layer of cushion gum.
2. The method for retreading a tire as recited in claim 1, wherein the step of applying the layer of cushion gum includes the step of pressing the layer of cushion gum against the buffed surface with sufficient pressure to force any air from between the casing and the layer of cushion gum.
3. The method for retreading a tire as recited in claim 1, wherein the step of applying the cushion gum to the buffed surface may be conducted at a temperature as low as sixty-five degrees Fahrenheit.
4. The method for retreading a tire as recited in claim 1, wherein the step of applying the layer of

AMENDED SHEET

- 13 -

cushion gum includes the step of applying a pair of shoulder strips to the buffed surface.

5. The method for retreading a tire as recited in claim 2, wherein the step of applying the layer of cushion gum includes the steps of cutting the layer generally transverse to the circumferential direction and splicing the layer at the cut region.

6. The method for retreading a tire as recited in claim 5, wherein the step of wrapping the tread layer includes the steps of cutting the tread layer generally transverse to the circumferential direction and splicing the tread layer at the cut region.

7. The method for retreading a tire as recited in claim 6, further comprising the steps of heating the tire; applying a vacuum within the envelope; and applying pressure to the outside of the envelope.

8. A method of retreading a tire, comprising the steps of:

removing old tire tread from a tire casing to present a buffed tire casing having a buffed surface;
maintaining the buffed surface free of tire retreading cement;

applying a layer of cushion gum directly to the buffed surface by stretching the layer of cushion gum between two to eight inches circumferentially about the buffed surface to adhere the cushion gum to the buffed surface;

squeezing the layer of cushion gum against the buffed surface;

wrapping a tread layer about the layer of cushion gum;

APPENDED SHEET

- 14 -

inserting the buffed tire casing, layer of cushion gum and tread layer into a curing envelope; and

then uniformly heating the combined buffed tire casing, tread layer and layer of cushion gum to form a vulcanized bond therebetween.

9. The method for retreading a tire as recited in claim 8, wherein the step of removing old tire tread includes grinding the tire tread from the tire casing.

10. The method for retreading a tire as recited in claim 9, wherein the step of maintaining the buffed surface includes removing contaminants from the buffed surface.

11. The method for retreading a tire as recited in claim 8, wherein the step of heating includes the steps of placing the combined tire casing, tread layer and layer of cushion gum within a pressure chamber.

12. The method for retreading a tire as recited in claim 11, wherein the step of inserting the buffed tire casing, layer of cushion gum and tread layer into a curing envelope includes the step of creating a vacuum within the envelope.

13. The method for retreading a tire as recited in claim 12, wherein the step of heating occurs while the combined tire casing, tread layer and layer of cushion gum are in the pressure chamber.

14. The method for retreading a tire as recited in claim 8, wherein the step of applying the cushion gum to the buffed surface may be conducted at a temperature as low as sixty-five degrees Fahrenheit.

- 15 -

15. A method for retreading a tire, comprising the steps of:

removing tire tread from a tire casing to present a buffed tire casing having a buffed surface;

maintaining the buffed surface free of tire retreading cement;

applying a layer of cushion gum directly to the buffed surface by stretching the layer of cushion gum circumferentially about the buffed surface to enhance adherence and conformation of the cushion gum to the buffed surface at a temperature as low as sixty five degrees Fahrenheit;

wrapping a tread layer about the layer of cushion gum;

inserting the buffed tire casing, layer of cushion gum and tread layer into a curing envelope; and

treating the tire to form bonds between the casing and the layer of cushion gum and between the tread layer and the layer of cushion gum.

16. A retreaded tire assembly prepared for insertion into a pressurized heating chamber comprising:

a tire casing having a pair of sidewalls and a radially outer wall spanning the pair of sidewalls, the radially outer wall having a buffed surface disposed about the outer circumference of the tire casing;

a layer of cushion gum disposed directly against the buffed surface; and

a tread layer disposed against the cushion gum; wherein the layer of cushion gum is mounted in tension between two to eight inches about the circumference of the tire casing.

AMENDED SHEET

- 16 -

17. The retreaded tire assembly as recited in claim 16, wherein the layer of cushion gum includes a center strip and a pair of shoulder strips.

18. The retreaded tire assembly as recited in claim 16, wherein the tread layer is arcuate in both the circumferential and the transverse directions.

19. The retreaded tire assembly as recited in claim 16, wherein the tread layer is arcuate only in the circumferential direction.

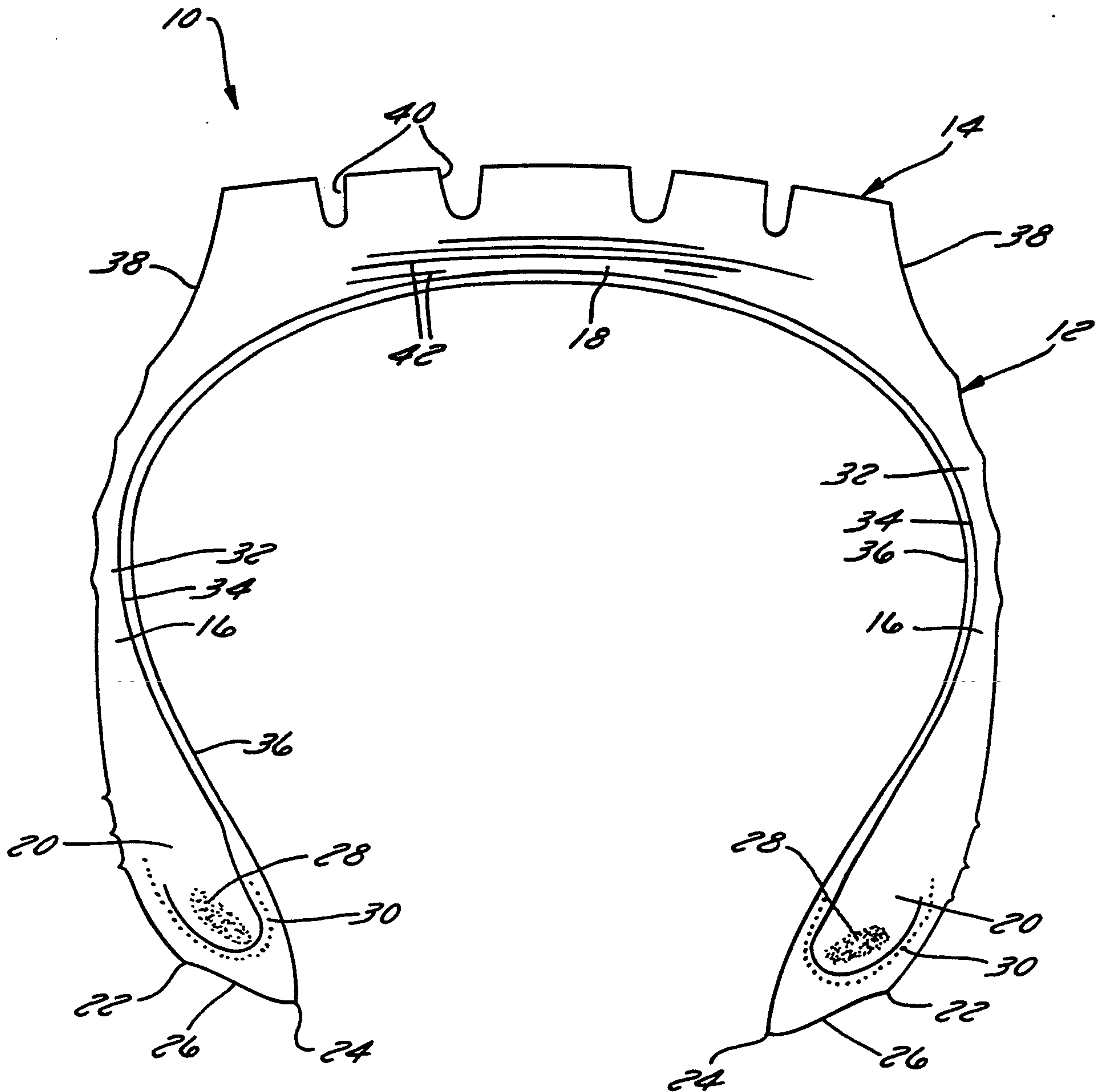

FIG. 1

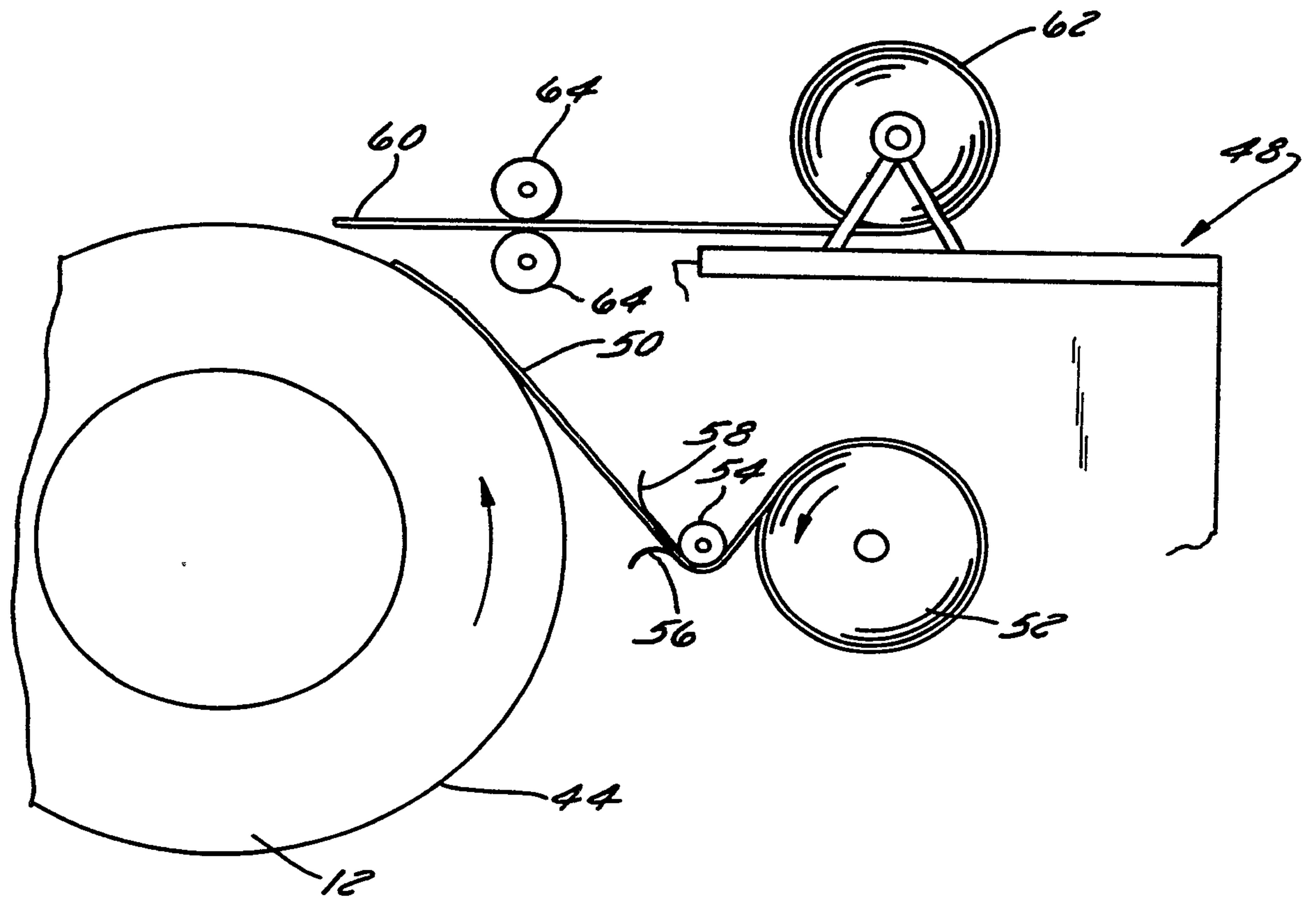

FIG. 3

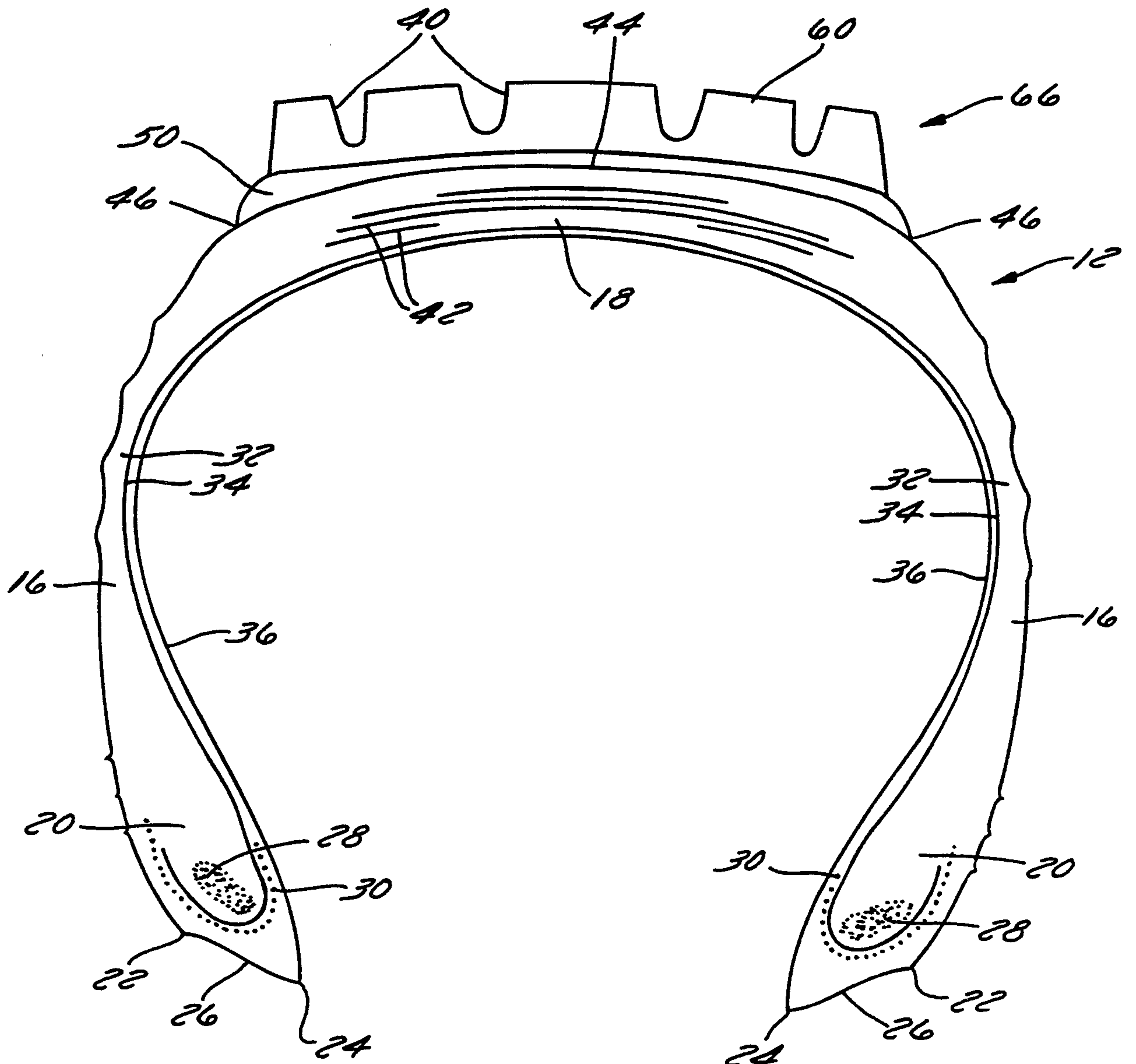

FIG. 4

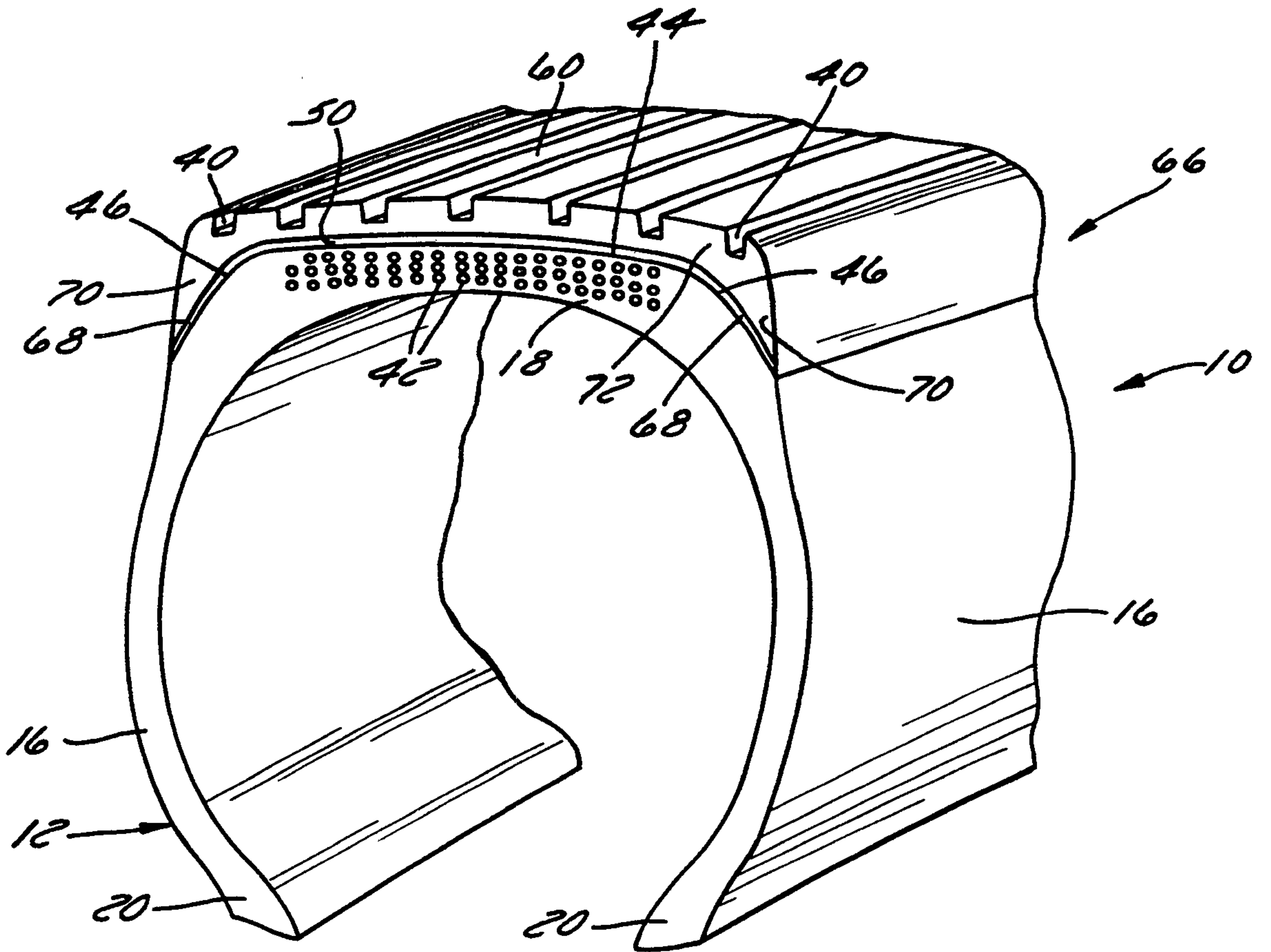

FIG. 5

