

C. M. BOCKOVEN.
CARBURETER.

APPLICATION FILED SEPT. 22, 1902. RENEWED DEC. 14, 1904.

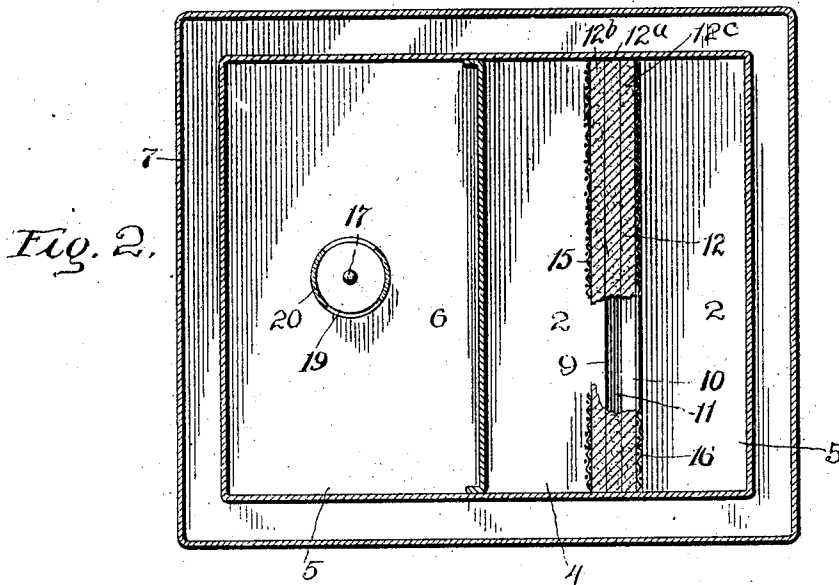
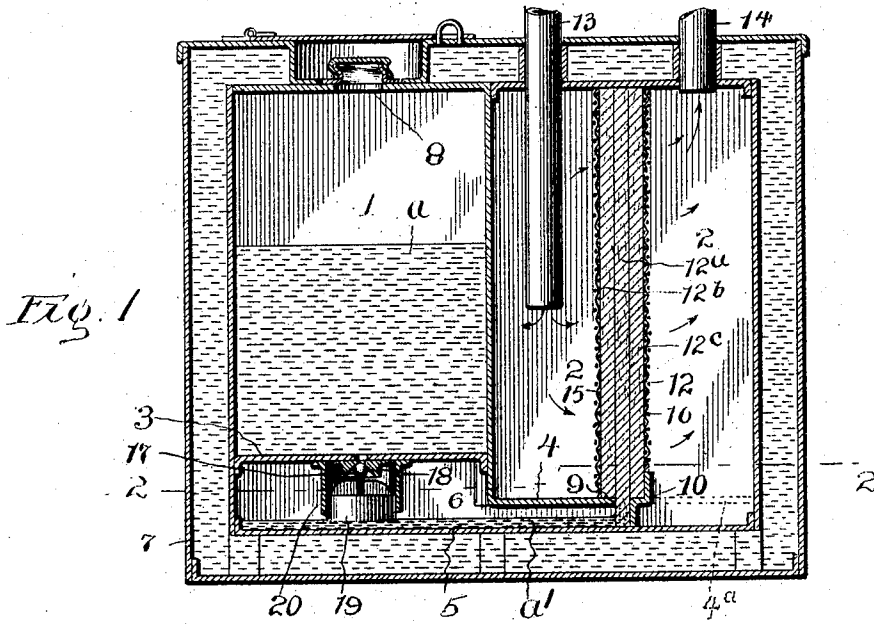
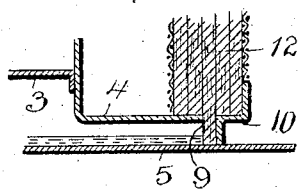

FIG. 3.



Witnesses:
W. A. Bombrough
C. O. Slurvey.

Inventor:
Charles M. Bockoven.

UNITED STATES PATENT OFFICE.

CHARLES M. BOCKOVEN, OF CHICAGO, ILLINOIS.

CARBURETER.

No. 796,557.

Specification of Letters Patent.

Patented Aug. 8, 1905.

Application filed September 22, 1902. Renewed December 14, 1904. Serial No. 236,854.

To all whom it may concern:

Be it known that I, CHARLES M. BOCKOVEN, a citizen of the United States, residing at Chicago, in the county of Cook and State of Illinois, have invented certain new and useful Improvements in Carbureters, of which the following is a specification.

My invention relates to certain improvements in carbureters for producing illuminating gas by the use of a hydrocarbon liquid or for enriching ordinary city gas; and the object of this invention is to produce a device wherein all of the residue will be taken up and the capacity of the apparatus may be increased without altering the size of the device.

To such end the invention consists in certain novel features of construction and arrangement, a description whereof will be found in the following specification and the essential features definitely pointed out in the claims.

In the accompanying drawings, Figure 1 is a central vertical longitudinal section through a carbureter embodying my invention. Fig. 2 is a horizontal section taken in the line 2 2 in Fig. 1, and Fig. 3 is a detail section illustrating the wick or vaporizing-curtain.

As shown in the drawings, the carbureter proper is divided into two main compartments 1 and 2, in both of which are false bottoms 3 4, forming, together with the side walls and bottom 5 of the carbureter proper, a regulating-chamber 6, communicating with both compartments 1 and 2. These compartments are surrounded by a water-jacket 7, serving to cool the device and to retard excessive evaporations. This water-jacket, however, may be dispensed with, if desired. The compartment 1 is the storage-chamber for the hydrocarbon and is provided with a suitable opening 8, by means of which it may be filled, said opening being ordinarily closed by any well-known cap or closure. The compartment 2 is the mixing-chamber and communicates with the storage-chamber through the medium of the regulating-chamber 6. As shown, the false bottom 4 terminates at 9, and adjacent thereto is a partition 10, having between the edge 9 of the false bottom 4 and said partition 10 a slot 11, the purpose of which will be directly explained. The partition 10, if desired, may be omitted and the false bottom carried over to the end wall of the mixing-chamber, as shown by the dotted lines 4^a, allowing the slot 11 to remain at the place shown. The mixing-chamber is divided in

two by a transversely-extending curtain or wick 12, composed of felt or such other fibrous structure capable of absorbing the liquid in the regulating-chamber and diffusing the same through itself. This wick or curtain may be made up of a number of thicknesses placed side by side and in close contact, and certain of these thicknesses are allowed to project down through the slot in the false bottom 4 into the liquid confined in the regulating-chamber, thereby drawing up the same by capillary attraction and spreading or diffusing this semivaporous fluid through the curtain. The false bottom 4 and partition 10 separate the mixing-chamber from the regulating-chamber, leaving the only escape for the liquid through the slot 11. This naturally retards and assists in keeping back any evaporation from chamber 6 except through slot 11. In Figs. 1 and 2 I have shown a central layer 12^a and two layers 12^b 12^c on either side thereof, the middle layer of which alone extends down into the liquid. I have found in actual practice that it is of great advantage to have a portion considerably less than the thickness of the curtain to extend into the liquid, as the section is quite sufficient for the required amount of evaporation. To increase the capacity of the device—that is to say, when it is desired to use a greater number of burners, and, consequently, a greater amount of gas is required—all that is necessary is to increase the number of layers of fibrous material upon the one extending down into the liquid, which evidently absorb more fluid and retard the passage of gas or air through the curtain, allowing the air or gas, however, to absorb more of the vaporized fluid in passing through the curtain. It is of course understood that when more burners are to be used a greater amount of air or gas must be forced through the carbureter. A pipe 13 leads from a suitable compressed-air supply or from the city illuminating-gas supply, and as the gas enters the mixing-chamber it expands and passes through the vaporizing-curtain and passes out through the pipe 14 to the points where the gas is to be used. Two screens or other suitable supports 15 16 hold the layers of the curtain in close contact with each other and support them in an upright position. These screens are secured in the chamber in any suitable manner—as, for instance, by soldering them to the sides thereof. Fig. 3 shows a greater number of thicknesses in proportion to the one extending into the liquid and is the

manner in which they are used to obtain greater capacity. One of the most important requirements in devices of this kind is to prevent the fluid from vaporizing too fast and from being carried off before it is thoroughly vaporized, because of the danger of liquefying again before reaching the points of consumption, and to overcome this difficulty the system of regulation by varying the thickness of the curtain is accomplished, which enables the vaporizing of the fluid to be controlled. The liquid is fed to the curtain through the regulating-chamber by a float-valve, preferably composed of a ball 17, seating upon a tapered seat 18 and connected to a suitable float 19, guided in a casing 20, and adapted to close the valve when raised by the liquid in the regulating-chamber when it reaches a certain predetermined height. Thus it will be seen that as the liquid is absorbed by the vaporizing-curtain and falls below the level into the regulating-chamber the float-valve is opened, permitting a sufficient quantity to flow into the regulating-chamber to keep the liquid therein approximately at the predetermined level. For convenience the liquid in the storage-chamber is lettered *a* and in the regulating-chamber *a'*.

The operation of my carbureter will be readily apparent. Air or other gases is forced into the mixing-chamber through the pipe 13, where it must pass through the vaporizing-curtain 12 before passing out through the escape-pipe 14. It is perfectly obvious that the air or gases in passing through this chamber will take up the vapors of the hydrocarbon liquid and in passing through the curtain will assist in the thorough vaporization. The layer 12^b also forms a filter for the gas and effectually removes any impurities therein. The layer 12^c takes up any hydrocarbon liquid which is drawn up by the central layer and not thoroughly vaporized on the central layer.

As above set forth, the wick or curtain may be of fibrous structure, permitting the passage of air or gas therethrough, and I wish it to be understood that when the term "wick" is used in the claims it refers to a structure capable of absorbing the fluid, but porous enough to permit the air or gas to pass freely through it.

I realize that various alterations and modifications of the various parts are possible, and I do not, therefore, desire to limit myself to their specific construction.

I claim as new and desire to secure by Letters Patent—

1. In a carbureter, a mixing-chamber, a chamber containing the hydrocarbon liquid, and a wick extended across the mixing-chamber and extending into the hydrocarbon liquid, said wick being of greater thickness in the mixing-chamber than in the liquid-chamber.

2. In a carbureter, a mixing-chamber, a chamber for the hydrocarbon liquid, and a wick through which air or gases may be forced to take up the vaporized liquid, said wick being composed of a plurality of thicknesses, a less number of which extend down into the hydrocarbon liquid than are in the mixing-chamber.

3. In a carbureter, a mixing-chamber, a storage-chamber for the hydrocarbon liquid, a regulating-chamber, a float-valve adapted to maintain a predetermined level in the regulating-chamber, and a wick extending across the mixing-chamber having its lower edge immersed in the liquid, the portion extending into the liquid being of less thickness than that within the mixing-chamber.

4. In a carbureter, a mixing-chamber, a wick extending across the same and having one of its edges immersed in a hydrocarbon liquid, the portion of the wick in the mixing-chamber being of greater thickness than that immersed in the fluid, an inlet-pipe entering the mixing-chamber upon one side of the curtain and an exit-pipe upon the other side thereof, whereby air or other gases in passing through said mixing-chamber will take up the vapors of the hydrocarbon liquid.

5. In a carbureter, the combination with a storage-tank and mixing-chamber, of a false bottom in said mixing-chamber, having a slot therein, and a vaporizing-wick extending across said mixing-chamber, said wick being of two or more thicknesses, one of which extends through said slot in the false bottom, into the fluid.

6. In a carbureter, the combination with a storage-tank and a mixing-chamber of false bottoms in said tank and chamber, forming below them a smaller chamber, means for regulating the flow of liquid from the storage-tank to the smaller chamber and a wick extending across the mixing-chamber and having its lower edge extending through a suitable opening in the false bottom into the smaller chamber.

7. In a carbureter, the combination with a mixing-chamber, of a regulating-chamber below the same, means for maintaining a predetermined level of hydrocarbon liquid therein, a wick extending across said mixing-chamber and having its lower edge immersed in said liquid, said lower edge being of less thickness than that in the mixing-chamber.

8. In a carbureter, the combination with a storage-tank and a mixing-chamber, of a regulating-chamber below said mixing-chamber, means for regulating the flow from the tank to the regulating-chamber and maintaining a predetermined level therein, a wick extending across the mixing-chamber and having one of its edges immersed in the liquid in the regulating-chamber, said edge being thinner than the body of the wick above, an inlet-pipe entering the mixing-chamber on one side of the

curtain, and a discharge-pipe opening out on the other side thereof, whereby air or other gases passing through said mixing-chamber may become thoroughly saturated with vapors from the hydrocarbon liquid.

9. In a carbureter, the combination with a mixing-chamber, and means for maintaining a predetermined quantity of hydrocarbon liquid in close proximity thereto, and a wick extending across the mixing-chamber and hav-

ing a portion immersed in the liquid, the thickness of the wick or curtain without the liquid being greater than that within.

In testimony whereof I have signed this specification this 18th day of September, 1902.

CHARLES M. BOCKOVEN.

Witnesses:

MASON A. BAMBOROUGH,
CHARLES O. SHERVEY.