

(12) STANDARD PATENT
(19) AUSTRALIAN PATENT OFFICE

(11) Application No. **AU 2015225964 B2**

(54) Title
High and low frequency sound absorption assembly

(51) International Patent Classification(s)
G10K 11/168 (2006.01) **E04B 9/00** (2006.01)
E04B 1/84 (2006.01)

(21) Application No: **2015225964** (22) Date of Filing: **2015.03.03**

(87) WIPO No: **WO15/132521**

(30) Priority Data

(31) Number	(32) Date	(33) Country
1451735	2014.03.04	FR

(43) Publication Date: **2015.09.11**

(44) Accepted Journal Date: **2020.06.25**

(71) Applicant(s)
Jean-Marc Scherrer

(72) Inventor(s)
Scherrer, Jean-Marc

(74) Agent / Attorney
Pizzeys Patent and Trade Mark Attorneys Pty Ltd, PO Box 291, WODEN, ACT, 2606, AU

(56) Related Art
US 20130148357 A1
US 20090250293 A1

(12) DEMANDE INTERNATIONALE PUBLIÉE EN VERTU DU TRAITÉ DE COOPÉRATION EN MATIÈRE DE BREVETS (PCT)

(19) Organisation Mondiale de la
Propriété Intellectuelle
Bureau international



(43) Date de la publication internationale
11 septembre 2015 (11.09.2015)

WIPO | PCT

(10) Numéro de publication internationale
WO 2015/132521 A1

- (51) Classification internationale des brevets :
G10K 11/168 (2006.01) E04B 9/00 (2006.01)
- (21) Numéro de la demande internationale :
PCT/FR2015/050509
- (22) Date de dépôt international :
3 mars 2015 (03.03.2015)
- (25) Langue de dépôt : français
- (26) Langue de publication : français
- (30) Données relatives à la priorité :
1451735 4 mars 2014 (04.03.2014) FR
- (72) Inventeur; et
- (71) Déposant : SCHERRER, Jean-Marc [FR/FR]; 5A rue du Collège, F-68400 Riedisheim (FR).
- (74) Mandataire : DULOUT, Maryse; Fidal Innovation, Tour Prisma, 4/6 avenue d'Alsace, F-92982 Paris La Défense (FR).
- (81) États désignés (sauf indication contraire, pour tout titre de protection nationale disponible) : AE, AG, AL, AM, AO, AT, AU, AZ, BA, BB, BG, BH, BN, BR, BW, BY, BZ, CA, CH, CL, CN, CO, CR, CU, CZ, DE, DK, DM,

DO, DZ, EC, EE, EG, ES, FI, GB, GD, GE, GH, GM, GT, HN, HR, HU, ID, IL, IN, IR, IS, JP, KE, KG, KN, KP, KR, KZ, LA, LC, LK, LR, LS, LU, LY, MA, MD, ME, MG, MK, MN, MW, MX, MY, MZ, NA, NG, NI, NO, NZ, OM, PA, PE, PG, PH, PL, PT, QA, RO, RS, RU, RW, SA, SC, SD, SE, SG, SK, SL, SM, ST, SV, SY, TH, TJ, TM, TN, TR, TT, TZ, UA, UG, US, UZ, VC, VN, ZA, ZM, ZW.

(84) États désignés (sauf indication contraire, pour tout titre de protection régionale disponible) : ARIPO (BW, GH, GM, KE, LR, LS, MW, MZ, NA, RW, SD, SL, ST, SZ, TZ, UG, ZM, ZW), eurasien (AM, AZ, BY, KG, KZ, RU, TJ, TM), européen (AL, AT, BE, BG, CH, CY, CZ, DE, DK, EE, ES, FI, FR, GB, GR, HR, HU, IE, IS, IT, LT, LU, LV, MC, MK, MT, NL, NO, PL, PT, RO, RS, SE, SI, SK, SM, TR), OAPI (BF, BJ, CF, CG, CI, CM, GA, GN, GQ, GW, KM, ML, MR, NE, SN, TD, TG).

Publiée :

- avec rapport de recherche internationale (Art. 21(3))
- avant l'expiration du délai prévu pour la modification des revendications, sera republiée si des modifications sont reçues (règle 48.2.h)

(54) Title : HIGH AND LOW FREQUENCY SOUND ABSORPTION ASSEMBLY

(54) Titre : ENSEMBLE D'ABSORPTION ACOUSTIQUE A HAUTES ET BASSES FREQUENCES

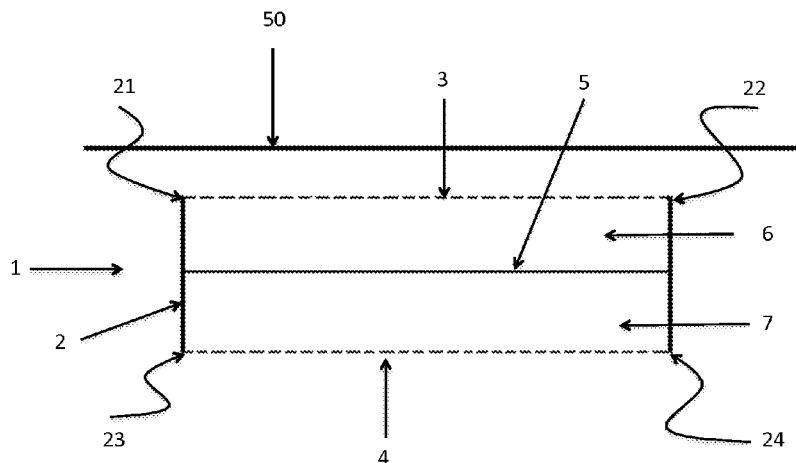

FIG. 1

(57) Abstract : The invention concerns a sound absorption assembly (1) comprising a body (2) having a tubular shape having ends closed respectively by first and second tensioned flexible micro-perforated layers (3, 4), and at least one planar diaphragm disposed inside the tubular body (2), between the flexible micro-perforated layers (3, 4), so as to delimit two spaces (6, 7) between said layers.

(57) Abrégé : L'invention concerne un ensemble d'absorption acoustique (1) comprenant un corps (2) de forme tubulaire présentant des extrémités fermées respectivement par une première et une deuxième nappes souples (3, 4) tendues micro-perforées, et au moins un diaphragme plan disposé à l'intérieur du corps (2) tubulaire, entre les nappes souples (3, 4) micro-perforées, de manière à délimiter deux espaces (6, 7) entre lesdites nappes.



WO 2015/132521 A1

HIGH AND LOW FREQUENCY SOUND ABSORPTION ASSEMBLY

TECHNICAL FIELD OF THE INVENTION

The invention relates to the field of false partitions, and in particular that of false ceilings and false walls. The invention relates more particularly to a sound-absorption assembly intended to be disposed in a room with a view to controlling the acoustic behaviour of the latter.

The sound-absorption assembly is intended in particular, but not exclusively, to be associated with a false partition provided inside a room.

PRIOR ART

Conventionally, false partitions are produced from frames able to be fixed to a wall or ceiling of a room and flexible sheets tensioned on these frames. Despite the increasing use thereof in various environments, false partitions produced with tensioned flexible sheets have a major drawback that is having poor acoustic properties. The tensioned sheets in fact reflect the sound waves, thus giving rise to a significant phenomenon of reverberation (or echo) of the sound waves.

In order to overcome this drawback, providing sound-absorption assemblies comprising flexible sheets provided with microperforations to increase the sound absorption and therefore to attenuate the reflection of

the sound waves is known from the prior art. By way of example, the application WO 2008/07737 can be cited, which describes a sound-absorbent assembly comprising two tensioned sheets provided with microperforations extending substantially parallel to the wall to be covered.

The sound-absorption assemblies of the prior art do however have several drawbacks. First of all, the acoustic assemblies of the prior art are essentially effective for the absorption of sounds at frequencies above 1500 Hz (high frequencies). On the other hand they remain ineffective for absorbing sounds at low frequency (frequencies below 300 Hz). Moreover, the acoustic assemblies of the prior art are fixed directly to the partition to be covered. However, when they are already equipped with false partitions produced with tensioned flexible sheets, it is necessary to remove them in order to allow the installation of the sound-absorption assemblies. The absorption zones therefore remain limited to the number of microperforated sheets.

The invention aims to remedy these problems by proposing a sound-absorption assembly offering satisfactory acoustic properties at both high and low frequencies while offering increased absorption capability compared with the sound-absorption assemblies of the prior art.

The invention also so aims to propose a sound-absorption assembly making it possible to illuminate

the room in which it is placed and/or to offer an aesthetic rendition while ensuring acoustic installation of the room.

SUBJECT MATTER OF THE INVENTION

To this end, and according to a first aspect, the invention proposes a sound-absorption assembly comprising a tubular-shaped body having ends closed respectively by first and second microperforated tensioned flexible sheets, and at least one planar diaphragm disposed inside the tubular body, between the microperforated flexible sheets so as to delimit two spaces between said sheets.

Thus, through the microperforated sheets and a planar diaphragm and the arrangement of these elements with respect to one another, the sound-absorption assembly affords absorption of the high- and low-frequency sounds and offers a sound-absorption zone that is greater than that offered by the sound-absorption assemblies of the prior art.

Low frequencies means frequencies below 300 Hz and high frequencies above 1500 Hz.

Moreover, microperforations means perforations having a diameter of less than 5 millimetres.

According to an advantageous embodiment, the diaphragm is fixed to the body by means of vibration-damping means. This prevents the vibrations to which

the diaphragm is subjected being damped by the damping means, thus preventing the acoustic assembly being subjected to vibrations.

Advantageously, the sound-absorption assembly comprises at least one tensioned internal flexible sheet interposed between at least one of the microperforated flexible sheets and the diaphragm. Depending on the use for which the acoustic assembly is intended, the internal flexible sheet may be either microperforated or devoid of any perforation.

Advantageously, the sound-absorption assembly comprises at least one panel of absorbent porous material or materials interposed between at least one of the flexible sheets (end sheets or internal sheet or sheets) and the diaphragm.

Advantageously, the sound-absorption assembly comprises luminous means provided in one of the spaces.

Advantageously, the diaphragm is a flexible metal plate.

Advantageously, the metal plate is disposed parallel to the flexible sheets (end sheets and internal sheet or sheets).

Advantageously, at least one of the flexible sheets (end sheets and internal sheet or sheets) is translucent.

The sound-absorption assembly is intended advantageously to be mounted on a false partition.

The invention also relates to an installation comprising a false partition and at least one sound-absorption assembly as previously described.

Preferably, said assembly is fixed to the false partition at a distance greater than or equal to a limit value. More particularly, it is a case of placing the acoustic assembly so as to dispose one of the microperforated flexible sheets at a distance greater than or equal to the limit value. The acoustic assembly thus offers a dual entrance for the sound waves, increasing the surface area of absorption of the waves and thus improving the sound insulation of the room in which the system is disposed. According to a particular embodiment, the limit value is around 2 centimetres.

BRIEF DESCRIPTION OF THE FIGURES

Other objects and advantages of the invention will emerge during the following description given with reference to the accompanying drawings, in which:

- figure 1 depicts a schematic view in cross section of a sound-absorption assembly according to a first embodiment, said assembly being shown mounted on a false ceiling;

- figure 2 shows a schematic view in cross section of a sound-absorption assembly according to a

second embodiment, said assembly being shown mounted on a false ceiling;

- figure 3 shows a schematic view in cross section of a sound-absorption assembly according to a third embodiment, said assembly being shown mounted on a false ceiling.

For more clarity, the identical or similar elements in the various embodiments are marked by identical reference signs in all the figures.

DETAILED DESCRIPTION OF THE FIGURES

In relation to figure 1, a sound-absorption assembly 1 according to a first embodiment is described, said assembly being shown mounted on a false ceiling 50. In order to avoid burdening the figures, the means for fixing the sound-absorption assembly to the false ceiling have not been shown. They may comprise any suitable means known to persons skilled in the art such as for example hangers or more elaborate systems such as those described in the patent application FR 2867797.

The sound-absorption assembly 1 comprises a body 2 with a tubular shape (hereinafter referred to as chamber body 2) closed at its ends respectively by first and second microperforated tensioned flexible sheets 3, 4. End sheets 3, 4 will be spoken of hereinafter. The microperforated sheets 3, 4 are intended to absorb the high-frequency sounds.

In the embodiment described, the chamber body 2 has a parallelepipedal form. It is understood that the chamber body 2 is not limited to this form, it being able to adopt any other form without departing from the scope of the invention. To allow fixing of the end sheets 3, 4, the ends of the chamber body 2 are advantageously provided with fixing means used in a conventional manner for fixing tensioned sheets. According to a particular configuration, provision may be made for the chamber body 2 to be formed by a profiled member or a plurality of abutted profile members, each profiled member forming a rail for receiving the attachment means provided at the peripheral rim of the sheets.

The acoustic-absorption assembly 1 also comprises a planar diaphragm 5 absorbing the low-frequency sound. In the embodiment illustrated, the diaphragm is a flexible metal sheet 5. The latter is disposed inside the tubular body 2, between the end sheets, so as to delimit between said sheets two spaces 6, 7, preferably separate. In other words, the spaces 6, 7 do not communicate with each other. Advantageously, the metal plate 5 is disposed parallel to the end sheets 3, 4.

According to a particularly advantageous embodiment, the metal plate 5 is fixed to the chamber body 2 by means of a fixing system provided with vibration-damping means (not shown). The damping means consist of one or more parts produced from a flexible

material so as to afford the absorption of vibrations between the metal plate 5 when the latter vibrates under the action of acoustic waves and the chamber body 2 supporting said plate. The metal plate 5 can thus vibrate and absorb the known frequencies without the acoustic assembly 1 also vibrating. By way of example, the damping means are Silentblocs®.

The metal plate 5 is advantageously situated at equal distances from the end sheets 3, 4.

The acoustic assembly 1 is mounted so as to have one of the end sheets 3, 4 facing the false ceiling 50, the chamber body 2 extending substantially perpendicular to the plane of the false ceiling 50. The acoustic assembly 1 is placed at a certain distance from the false ceiling 50 so as to duplicate the acoustically treated surfaces. This is because, by being placed at a certain distance from the false ceiling 50, the acoustic assembly 1 offers a top surface (corresponding to the end sheet 3) and a bottom surface (corresponding to the end sheet 4), both microperforated, absorbing the high-frequency sounds. So that the acoustic assembly 1 can thus serve as a double acoustic chamber, it is necessary to place the acoustic assembly 1 at a distance of at least 2 centimetres from the false ceiling. Hereinafter, the end sheet closest to the false ceiling 50 will be referred to as the top end sheet 3 and the end sheet situated furthest away from the false ceiling 50 will be referred to as the bottom end sheet 4.

In the embodiment illustrated in figure 2, the acoustic absorption assembly 10 repeats all the features of the previously described element.

The acoustic assembly 10 further comprises luminous means 8 provided in the lower space 7 (the space delimited between the metal plate 5 and the bottom metal plate 4). The luminous means 8 are fixed, directly or indirectly, to the bottom face of the metal plate 5, as well as to the partition portion of the chamber body 2 situated under the metal plate 5. It is of course obvious that the invention is not limited to this configuration, the luminous means 8 being able to be provided solely on the metal plate 5 or solely on the partition portion of the chamber body 2.

Advantageously, the acoustic assembly 10 comprises a flexible internal sheet 9 interposed between the bottom metal plate 4 and the metal plate 5. The internal sheet 9 has no perforation. Depending on the illuminating power of the luminous means 8, the internal sheet 9 will be translucent or not. The internal sheet 9 is disposed parallel to the end sheets 3, 4.

The acoustic assembly 10 further comprises a panel of sound-absorbent porous material or materials 11 interposed between the end sheet 3 and the metal plate 5. This thus improves the acoustic insulation. It is of course evident that, if the absorption assembly does not comprise any luminous means, a panel of

absorbent porous material or materials 11 could also be provided in the bottom space 7 delimited by the metal plate 5 and the bottom end sheet 4, in replacement for or in addition to the one disposed in the top space 6. Moreover, in the embodiment illustrated, the panel of porous material or materials 11 is formed in a single piece and fills the whole of the top acoustic space. It is of course obvious that the panel of porous material or materials 11 could be formed by a plurality of layers of the same or different porous materials and could also have smaller dimensions, in particular in order to limit the weight of the acoustic assembly.

In the embodiment illustrated in figure 3, the sound-absorption assembly 20 repeats all the features of the element described with reference to figure 1.

The sound-absorption assembly 20 further comprises two microperforated flexible internal sheets 12, 13, interposed between the bottom end sheet 4 and the metal plate 5. The internal sheets 12, 13 are disposed parallel to each other and to the metal plate 5. In order to improve the sound insulation, two panels of sound-absorbent porous material or materials 11, 14, one being interposed between the metal plate 5 and the adjacent internal layer 12, the other being interposed between the metal plate 5 and the top end sheet 3. It is of course obvious that the invention is not limited to this configuration. A sound-absorption assembly comprising only one or more than two acoustic (ie microperforated) internal sheets 12, 13 may be

provided, these being able to be placed in one or other or both spaces 6, 7 delimited by the metal plate 5. Moreover, the absorption assembly 20 may be provided without a panel of absorbent porous material or materials or with only one, in this case disposed either in the top space 6 or in the bottom space 7. Moreover, in the embodiment illustrated, the panels of absorbent porous material or materials 11, 12 are formed in a single piece and fill all the acoustic spaces. It is of course obvious that the panels 11, 12 could be formed by a plurality of layers of the same or different absorbent material or materials and could also have smaller dimensions, in particular in order to limit the weight of the acoustic assembly.

In the embodiments described, the end sheets 3, 4 are shown disposed so as to lie in a plane containing the end edges 21, 22, 23, 24 of the chamber body 2. Provision may also be made for these end layers to be disposed at the ends of the chamber body 2 but in a plane slightly offset with respect to the plane passing through the end edges 21, 22, 23, 24 of the chamber body 2.

Moreover, in the embodiments previously described, the diaphragm chosen is a metal plate. It is of course obvious that the above description also applies to diaphragms other than a metal plate.

In the previously described embodiments, the false partition facing which the acoustic assembly is

placed is a false ceiling, the assembly then forming an assembly suspended horizontally. It is of course obvious that the false partition facing which the acoustic assembly is placed may also be a wall, the acoustic assembly then forming an assembly suspended vertically. According to a particular embodiment, an acoustic assembly arranged so as to have one part intended to be placed facing the ceiling and another part placed facing a wall, the acoustic assembly then forming a horizontally and vertically suspended assembly, may also be provided.

Though the mounting of a single acoustic assembly on a false partition is described above, it will be understood clearly that an installation in which the false partition is equipped with a plurality of acoustic assemblies may be provided.

Moreover, in the embodiments described above, the acoustic assembly is associated with a false partition, and in this case a false ceiling. It is of course obvious that the acoustic assembly according to the invention could also be used directly on a ceiling or wall.

The invention is described above by way of example. Naturally a person skilled in the art is in a position to implement different variant embodiments of the invention without departing from the scope of the invention.

CLAIMS

1. A sound-absorption assembly comprising:
a tubular-shaped body having ends closed respectively by first and second microperforated tensioned flexible sheets and at least one low-frequency sound absorbing planar diaphragm disposed inside the tubular body, between the microperforated tensioned flexible sheets, so as to delimit two spaces between said sheets, said diaphragm being configured to be fixed to the body and maintained at a distance from the microperforated tensioned flexible sheets.

2. The sound-absorption assembly according to claim 1, wherein the diaphragm is fixed to the body by means of vibration-damping means.

3. The sound-absorption assembly according to claim 1 or claim 2, wherein said sound-absorption assembly comprises at least one internal flexible sheet interposed between at least one of the microperforated flexible sheets and the diaphragm.

4. The sound-absorption assembly according to claim 3, wherein the internal flexible sheet is microperforated.

5. The sound-absorption assembly according to claim 3, wherein the internal flexible sheet is devoid of perforation.

6. The sound-absorption assembly according to any one of claims 1 to 5, wherein said sound-absorption assembly comprises at least one panel of absorbent porous material or materials interposed between at least one of the flexible sheets and the diaphragm.

7. The sound-absorption assembly according to any one of claims 1 to 6, wherein said sound-absorption assembly comprises luminous means provided in one of the spaces.

8. The sound-absorption assembly according to any one of claims 1 to 7, wherein the diaphragm is a flexible metal plate.

9. The sound-absorption assembly according to claim 8, wherein the metal plate is disposed parallel to the flexible sheets.

10. The sound-absorption assembly according to claim any one of claims 1 to 9, wherein at least one of the flexible sheets is translucent.

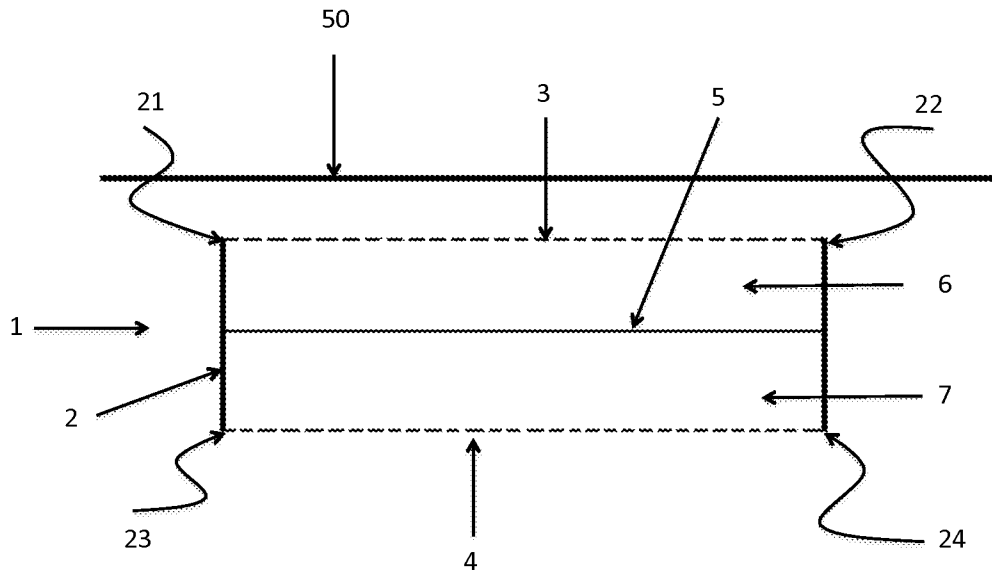

FIG. 1

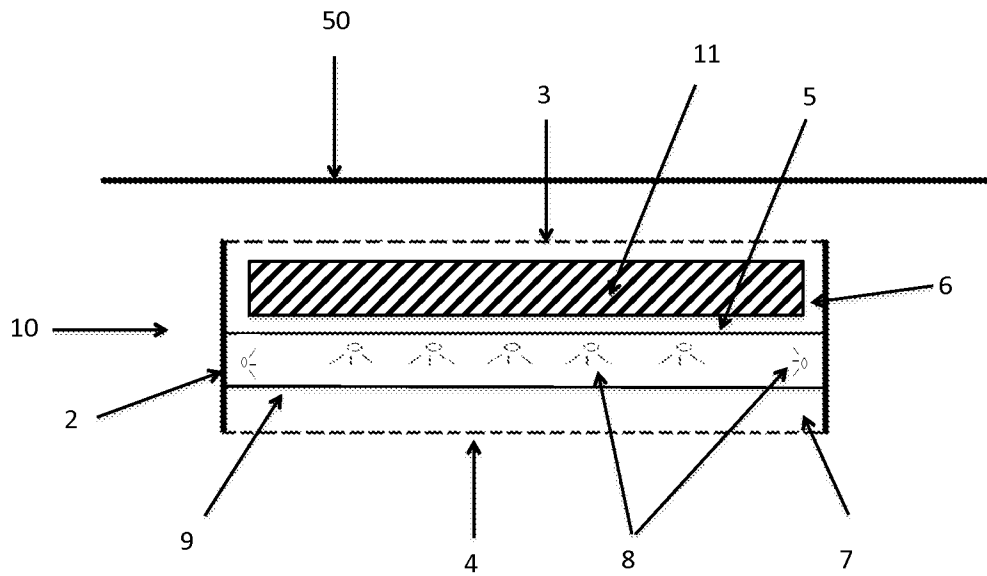

FIG. 2

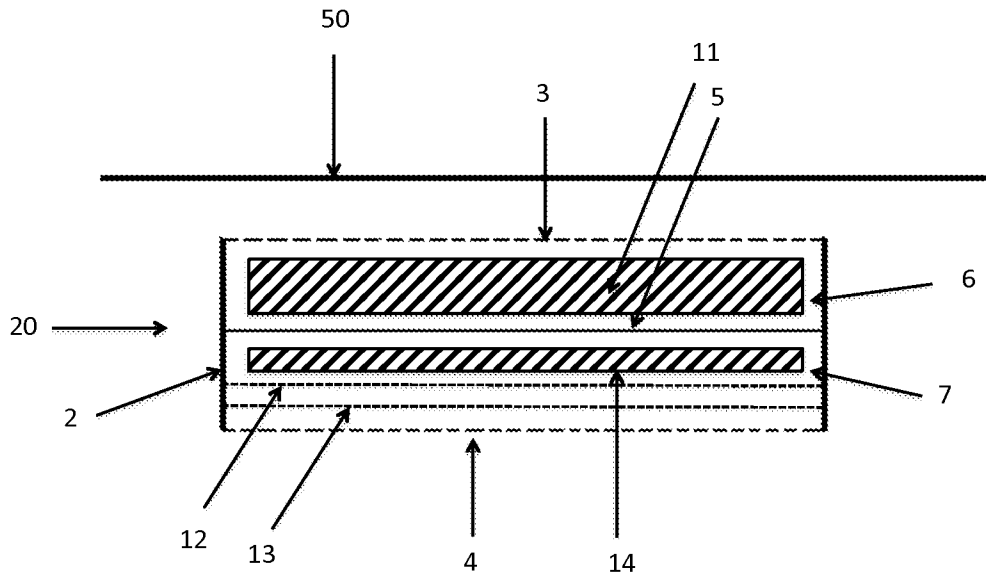

FIG. 3