



INTERNATIONAL APPLICATION PUBLISHED UNDER THE PATENT COOPERATION TREATY (PCT)

<p>(51) International Patent Classification ⁷ : C13D 1/00, A23L 3/3508, C12H 1/00</p>	<p>A1</p>	<p>(11) International Publication Number: WO 00/52212</p> <p>(43) International Publication Date: 8 September 2000 (08.09.00)</p>
<p>(21) International Application Number: PCT/US00/05624</p> <p>(22) International Filing Date: 6 March 2000 (06.03.00)</p> <p>(30) Priority Data: 199 09 832.8 5 March 1999 (05.03.99) DE</p> <p>(71) Applicant (for all designated States except US): HAAS HOP PRODUCTS, INC. [US/US]; 5185 MacArthur Boulevard, N.W., Washington, DC 20016-3341 (US).</p> <p>(72) Inventors; and (75) Inventors/Applicants (for US only): MAYE, John, Paul [US/US]; 5185 MacArthur Boulevard, N.W., Washington, DC 20016-3341 (US). BEDDIE, David [GB/GB]; Eardiston Nr., Tenbury Wells, Worcestershire, Hereford and Worcester WR15 8JJ (GB).</p> <p>(74) Agent: HARRIMAN, Erin, M.; Morgan, Lewis & Bockius LLP, 1800 M. Street, N.W., Washington, DC 20036-5096 (US).</p>	<p>(81) Designated States: AE, AL, AM, AT, AU, AZ, BA, BB, BG, BR, BY, CA, CH, CN, CR, CU, CZ, DE, DK, DM, EE, ES, FI, GB, GD, GE, GH, GM, HR, HU, ID, IL, IN, IS, JP, KE, KG, KP, KR, KZ, LC, LK, LR, LS, LT, LU, LV, MA, MD, MG, MK, MN, MW, MX, NO, NZ, PL, PT, RO, RU, SD, SE, SG, SI, SK, SL, TJ, TM, TR, TT, TZ, UA, UG, US, UZ, VN, YU, ZA, ZW, ARIPO patent (GH, GM, KE, LS, MW, SD, SL, SZ, TZ, UG, ZW), Eurasian patent (AM, AZ, BY, KG, KZ, MD, RU, TJ, TM), European patent (AT, BE, CH, CY, DE, DK, ES, FI, FR, GB, GR, IE, IT, LU, MC, NL, PT, SE), OAPI patent (BF, BJ, CF, CG, CI, CM, GA, GN, GW, ML, MR, NE, SN, TD, TG).</p> <p>Published <i>With international search report. Before the expiration of the time limit for amending the claims and to be republished in the event of the receipt of amendments.</i></p>	
<p>(54) Title: PROCESS FOR CONTROLLING MICRO-ORGANISMS IN AN AQUEOUS PROCESS MEDIUM</p>		
<p>(57) Abstract</p> <p>The invention relates to an improved process for controlling micro-organisms in an aqueous process medium comprising adding a hop acid, characterized in, that the hop acid is dissolved in an aqueous alkaline medium and added to the process medium, wherein the pH of the added, solution is higher than the pH of the process medium and the hop acid passes from the salt form into the free acid form within the process medium. In another embodiment, the invention relates to an improved process for controlling the bacterial growth in a distillery, the improvement comprising adding to the yeast or fermentor feed streams of the distillery an effective antibacterial amount of an isomerized hop acid.</p>		

FOR THE PURPOSES OF INFORMATION ONLY

Codes used to identify States party to the PCT on the front pages of pamphlets publishing international applications under the PCT.

AL	Albania	ES	Spain	LS	Lesotho	SI	Slovenia
AM	Armenia	FI	Finland	LT	Lithuania	SK	Slovakia
AT	Austria	FR	France	LU	Luxembourg	SN	Senegal
AU	Australia	GA	Gabon	LV	Latvia	SZ	Swaziland
AZ	Azerbaijan	GB	United Kingdom	MC	Monaco	TD	Chad
BA	Bosnia and Herzegovina	GE	Georgia	MD	Republic of Moldova	TG	Togo
BB	Barbados	GH	Ghana	MG	Madagascar	TJ	Tajikistan
BE	Belgium	GN	Guinea	MK	The former Yugoslav Republic of Macedonia	TM	Turkmenistan
BF	Burkina Faso	GR	Greece	ML	Mali	TR	Turkey
BG	Bulgaria	HU	Hungary	MN	Mongolia	TT	Trinidad and Tobago
BJ	Benin	IE	Ireland	MR	Mauritania	UA	Ukraine
BR	Brazil	IL	Israel	MW	Malawi	UG	Uganda
BY	Belarus	IS	Iceland	MX	Mexico	US	United States of America
CA	Canada	IT	Italy	NE	Niger	UZ	Uzbekistan
CF	Central African Republic	JP	Japan	NL	Netherlands	VN	Viet Nam
CG	Congo	KE	Kenya	NO	Norway	YU	Yugoslavia
CH	Switzerland	KG	Kyrgyzstan	NZ	New Zealand	ZW	Zimbabwe
CI	Côte d'Ivoire	KP	Democratic People's Republic of Korea	PL	Poland		
CM	Cameroon	KR	Republic of Korea	PT	Portugal		
CN	China	KZ	Kazakstan	RO	Romania		
CU	Cuba	LC	Saint Lucia	RU	Russian Federation		
CZ	Czech Republic	LI	Liechtenstein	SD	Sudan		
DE	Germany	LK	Sri Lanka	SE	Sweden		
DK	Denmark	LR	Liberia	SG	Singapore		
EE	Estonia						

**PROCESS FOR CONTROLLING MICRO-ORGANISMS
IN AN AQUEOUS PROCESS MEDIUM**

5

FIELD OF THE INVENTION

The present invention relates to an improved process for controlling micro-organisms in an aqueous process medium by using hop acids as the active substance. The invention also relates to an improved process for controlling the bacterial growth in a distillery using an isomerized hop acid.

BACKGROUND OF THE INVENTION

It is known that compounds derived from flowers of the hop plant (*Hululus lupulus L.*) contribute a desirable bitter flavor to beer. Commercial processes which extract the active compounds, such as, alpha acids and beta acids, from hops and convert them to the desired hop flavors, e.g., isoalpha acids, rho-isoalpha acids, tetrahydroisoalpha acids and hexahydroisoalpha acids, at relatively high yields. The commercially produced hop product may then be added post-fermentation to maximize utilization and provide consistent hop flavor.

Hops have been used for many years for the purpose of contributing a clean bitter taste to beer. Further, it is known that certain hop acids exhibit anti-bacterial effects in sugar containing aqueous mediums. For example, European Patent Application No. 681 029 A2 discloses a process for inhibiting thermophilic micro-organisms in the presence of sucrose aqueous medium, in which a hop based product is added to a sucrose aqueous medium at temperatures between 50°C and 80°C.

Further, U.S. Patent No. 5,286,506 relates to a process of applying a solution containing beta acids to a solid food product to prevent growth of *Listeria*. According to Arch. Mikrobiol. 94 (1973), p. 159 - 171 beta acids exhibit the highest bacteriostatic

effect in comparison to alpha acids and isoalpha acids, however, because of its poor solubility, certain concentrations of beta-acid cannot be exceeded.

During the manufacturing of spirits, there are many areas where bacteria contamination can occur. This contamination generally originates from the feed material or the material to be fermented. Because the feed material is generally an agricultural product, coming from the field, bacterial contamination is unavoidable. The goal at most distilleries is to perform the fermentation quickly as possible since alcohol itself has a bactericidal effect at above 6 wt%. Unfortunately, distilleries with severe bacteria problems cannot get around this problem and are forced to use antibiotics or sacrifice yield and product quality.

A common area where contamination occurs is in the yeast growing tanks. Because it can take many hours to grow a new lot of yeast for fermentation, the conditions and time periods are ideal for bacterial growth. Once a sufficient amount of yeast is produced it is transferred to an empty fermentor. Over a period of several hours the fermentor is filled with feed material. During this filling time and afterwards the yeast and bacteria start consuming the fermentable sugars. If the bacteria content is high, several problems can occur. One problem is the conversion of sugar into organic acids like lactic acid and acetic acid. This reduces alcohol yield and creates by-products which can effect the quality of the distilled spirit. If the bacteria contamination is extremely high, one can experience yeast flocculation in the fermentor. This can stop a fermentation in its tracks.

Some distilleries purchase whole hops or hop pellets to control bacteria problems. The hops are boiled in a tank to convert the alpha acids to isoalpha acids. The boiled aqueous solution is then poured into the fermentor. Although this will control bacteria growth, it is very inefficient, costly and variable. Specifically, hops are an agricultural product where its components, *e.g.*, alpha acids, beta acids, uncharacterized resins and hop oils vary year to year, lot to lot and field to field. Further, the required boiling to isomerize the alpha acids into isoalpha acids is variable. Accordingly, there remains a need to provide a convenient and effective method for treating distilleries to control bacteria growth. The present invention answers this need.

SUMMARY OF INVENTION

It has been discovered that when an aqueous alkaline solution of hop acid is added to a process medium having a pH less than the pH of the alkaline hop acid solution, the hop acid is especially effective at controlling micro-organisms. Indeed, the overall usage of hop acid for obtaining the desired effect can be enormously reduced. Accordingly, the invention relates to a process for controlling micro-organisms in an aqueous process medium comprising adding an aqueous alkaline solution of a hop acid to the process medium, wherein the pH of the aqueous alkaline hop solution is higher than the pH of the process medium.

10 As a result of the low dosage quantity of added solution compared to the process medium, the solution adapts almost entirely the pH of the process medium when added to the process medium and the hop acid passes from the disassociated form (salt form) to the associated (free acid), anti-bacterial effective, form. Surprisingly, hop acid is especially effective as an anti-bacterial agent when used in this manner. In addition
15 different forms of hop acids can be used which could otherwise not be used or could only be used at low effectiveness.

It has also been discovered that, isomerized hop acids are particularly effective at controlling the bacterial growth in the process streams of distilleries. Indeed, by using a standardized solution of isomerized hop acids, one is able to accurately dose the exact
20 amount of hop acid required to control bacterial growth.

BRIEF DESCRIPTION OF THE DRAWINGS

Figure 1 is a diagram of the preferred process sequence for preparing an aqueous alkaline beta acid solution used in the process of the invention.

25 Figure 2 is a diagram of a preferred embodiment of the invention for controlling the bacterial growth in a distillery where the fermentable solution is stored as a concentrate and the isomerized hop acid is dosed into the feed streams going to the yeast growing tanks and fermentors immediately after dilution.

Figure 3 is a diagram showing the dilution of concentrated molasses in the
30 distillery treated in accordance with Example 5.

Figure 4 is a diagram demonstrating how the yeast in the yeast growing tanks were grown in the distillery treated in accordance with Example 5.

DETAILED DESCRIPTION

5 The invention relates to a process for controlling micro-organisms in an aqueous process medium comprising adding an aqueous alkaline solution of a hop acid to the process medium, wherein the pH of the aqueous alkaline hop solution is higher than the pH of the process medium.

10 The hop acid is a natural hop acid or a derivative thereof, such as, alpha acid, beta acid, tetrahydroalpha acid (THAA), or hexahydrobeta acid (HHBA), or mixtures thereof; an isomerized hop acid or a derivative thereof, such as, isoalpha acid (IAA), rhoiso alpha acid (RIAA), tetrahydro isoalpha acid (THIAA) or hexahydro isoalpha acid (HHIAA) or mixtures thereof. Alpha acids contained in the hop acid may be transformed into isoalpha acids during the preparation of the hop acid solution and maintain their anti-
15 bacterial effect.

 Depending on the hop acid product, the concentration of hop acid in the aqueous solution will vary. For example, the concentration of tetrahydroisoalpha acid in aqueous solution is generally 10 wt.% while the concentration of isoalpha acid can be as high as 30 wt.%. Generally, the final concentration of acid in the solution ranges from about 2 to
20 about 40 wt.%, in some cases from about 5 to about 20 wt. %, or from about 10 to about 15 wt. %. Higher concentrations may be appropriate where longer transport times are required.

 Generally, hop acids in their acid form exhibit low solubility in water. However, hop acids can be mixed with an alkali metal hydroxide, such as, potassium hydroxide, to
25 make a water soluble alkali metal salt of the hop acid. Accordingly, in the process for controlling micro-organisms according to the invention, it is advantageous to use alkali hydroxides, specifically potassium hydroxide or sodium hydroxide or a mixture thereof as the alkaline medium. The concentrations of the alkaline medium preferably ranges from about 1 to about 4 wt. %, more preferably from about 2 to about 3 wt. %.

As discussed above, the pH of the aqueous alkaline hop solution is higher than the pH of the process medium. As a result of the low dosage quantity of added solution compared to the process medium, the solution adapts almost entirely the pH of the process medium when added to the process medium and the hop acid passes from the disassociated form (salt form) to the associated (free acid), anti-bacterial effective, form. Preferably, the pH of the aqueous alkaline hop acid solution added to the process medium ranges from about 7.5 to about 13.0, more preferably from about 9.5 to about 11.0. A high bactericidal efficiency is achieved by using the solution in this range. The solution can be added without the danger of seriously damaging human skin. Furthermore, the solution does not create unpleasant or injurious vapors, unlike other chemical agents.

In a preferred embodiment, the aqueous alkaline solution of hop acid is prepared according to the following steps:

- a) provide an aqueous medium;
- b) heat;
- 15 c) adding a hop acid, preferably, melted hop acid, such that the final concentration of the hop acid is within a predefined range of concentration;
- d) adding an aqueous alkaline medium to obtain a pre-defined pH;
- e) mixing the alkaline medium with the added hop acid;
- f) maintaining the mixture in a raised temperature range within a predefined time
- 20 period;
- g) separating the solution of hop acid from the mixture and
- h) cooling-down the solution of hop acid.

Figure 1 is a diagram of the preferred process sequence for preparing an aqueous alkaline beta acid solution used in the process of the invention. In a preferred embodiment, an aqueous solution of potassium hydroxide is heated to about 60 to about 80°C, preferably from about 65 to 75°C, most preferably from about 70 to about 75°C and the hop acid, *e.g.*, melted beta acid, is added into to the potassium hydroxide solution. The temperature of the mixture is subsequently maintained for about 15 to 30 minutes or until the mixture separates into a clear, alkaline beta acid solution and an oil containing components. The clear, alkaline beta acid solution generally having a pH of

about 10 to about 10.5 is separated from the mixture and is then cooled to a temperature below room temperature, preferably to about 2 to about 7°C. This is subsequently dosed into the process medium discontinuously, *e.g.*, by using shock dosage or continuously.

This process of preparing the aqueous alkaline solution of hop acid, enables the preparation of a solution, which can be stored and/or transported at higher concentrations of hop acids over longer periods. Under these conditions these solutions are very stable. Further, its composition means that the solution can be dosed by pouring it in manually through hatches since it will not damage human skin, nor does the alkaline solution create unpleasant or injurious vapors unlike other chemical agents. Such solution provides appropriate characteristics for transport, the way to apply the solution and storage because of alkaline behavior. The process also provides a reduction of the amount of hop acid used in comparison to the processes according to the prior art. Also the pH of the solution is selected to ensure the highest possible increase in effect when it is used directly. The solution can also be dosed through the closed dosage systems for the emission free dosage of common anti-bacterial substances. The procedural steps are able to be changed in their sequence in time. The aforementioned sequence provides a very accurate definition of the pH of the aqueous alkaline hop acid solution.

In the process for controlling micro-organisms of the invention, the aqueous alkaline hop acid solution can be added to the process medium continuously or discontinuously, *e.g.*, using shock dosage. For example, for shock dosage, the aqueous alkaline hop solution is periodically added to the process medium, *e.g.*, the dosage is made at defined times within very short time intervals at which locally and for a short time interval high concentrations can be adapted. The high local concentrations achieved by this kind of dosing avoid the adaptation of the micro-organisms. The solution may be manually dosed into the process medium. Alternatively, the solution may be added to the process medium through closed dosing systems. That means that control of micro-organisms may be done under the use of the process installations (closed dosing systems) already available.

Generally, the temperature of the process medium to be treated is below 100°C, preferably below 50°C most preferably below 30°C. The concentrations of hop acid used

in the process medium is preferably in the range of about 0.1 to about 50 ppm, more preferably in the range of about 1.0 to about 35 ppm, most preferably from about 2 to about 4 ppm. As discussed above, in the process medium the aqueous alkaline hop acid solution mixes with the slightly acid or at least less alkaline reacting process medium. As
5 a result of the low dosage quantities of the highly concentrated hop acid solution, *e.g.*, beta acid or alpha acid solution, it adapts almost entirely to pH of the process medium, where upon the hop acid transforms from its salt form into the anti-bacterially effective free acid form.

In another embodiment, melted, commercial hop acids, such as beta acids, can be
10 directly added to the process medium. In such a process the melt is mixed with alkaline solution at an increased temperature shortly before a shock dosing. After the melt is dissolved, the entire mixture is dosed as a single shock. For short periods, strong alkaline conditions, which would lead to a loss of hop acids during interim storage, can be chosen.

The process for controlling micro-organisms according to the invention can be
15 automated by the use of time controls for the dosing pumps and valves. In this case, too, an increase of efficiency occurs. The improved effect means that the overall concentration of active ingredients can be reduced, which produces a number of advantages. Either reduced costs are achieved through lower dosing or the same dosing produces a better effect. For hop acids with the same concentration the transport volume
20 is reduced, because of the greater efficiency.

The process for controlling micro-organisms according to the invention can be applied in an advantageous way in distilleries for the production of non-beer alcoholic drinks, specifically of spirits or in the production process of wine and wine containing drinks, further in the production of natural ethanol and pharmaceutical drugs. The
25 invention can also be used in the production of all kinds of dairy products, yeast, fruit juices and tinned foods in aqueous solution. Furthermore the process may be used in the formulation of cosmetic and detergent compositions.

It has also been discovered that, isomerized hop acids and derivatives thereof are particularly effective at controlling the bacterial growth of distilleries. The isomerized
30 hop acids are easier to use than traditional hops. Indeed, by using a standardized solution

of isomerized hop acids, one is able to accurately dose the exact amount of hop acid required to control bacterial growth.

Accordingly, in another embodiment, the invention relates to a process for controlling the bacterial growth in a distillery comprising adding an effective
5 antibacterial amount of an isomerized hop acid to the process streams, *e.g.*, yeast and/or fermentor streams of the distillery. In a preferred embodiment, the process streams are treated with an alkaline aqueous solution of isomerized hop acid. Isomerized hop acids at concentrations as low as 2 ppm in the process medium can effectively control bacterial growth. Preferably, the concentration of hop acid ranges from about 1 to about 20 ppm,
10 more preferably from about 2 to about 4 ppm in the process medium. Because isomerized hop acids are very insoluble at concentration at about 100 ppm, one should avoid localized high concentrations. Accordingly, the isomerized hop acid is preferably metered into the process very slowly, for example, by the use of small dosing pumps.

Figure 2 demonstrates an example where the fermentable solution is stored as a
15 concentrate and the isomerized hop acid is dosed into the feed streams going to the yeast growing tanks and fermentors immediately after dilution. At very high concentrations >80 brix no bacterial growth occurs, although the bacteria are still present in the feed material. After diluting the feed material to a fermentable concentration of about 25 brix bacterial growth can occur. By adding the isomerized hop acid at this point in the
20 process one can inhibit bacteria growth right from the start.

An alternative to dosing the isomerized hop acid to both the yeast growing tanks as well as the fermentors is to dose a higher concentration of the hop acid just into the yeast growing tanks. Following yeast growth the yeast solution, containing the isomerized hop acid, is transferred to an empty fermentor. As the fermentor is being
25 filled, fermentation is taking place and the hop acid concentration is being diluted. If the correct amount of isomerized hop acid is added to the yeast growing tanks dilution in the fermentor will provide a final isomerized hop acid concentration of about 2 to about 4 ppm. At this concentration the isomerized hop acid can still control bacteria growth.

Suitable isomerized hop acids useful in the process of the invention include
30 isomerized hop acids and derivatives thereof, such as, isoalpha acids (IAA), rhoiso alpha

acids (RIAA), tetrahydro isoalpha acids (THIAA), hexahydro isoalpha acid (HHIAA) or mixtures thereof. THIAA and HHIAA are particularly effective at controlling bacteria growth.

There are many advantages to using isomerized hop acids as antimicrobial agents for the distilling industry. First, hop acids are natural products which are used to bitter beer consumed by millions of people every day. Clearly, they are safe for human consumption. Further, because these hop acids have boiling points over 200°C one never needs to be concerned with contaminating the distilled product with hops and therefore one can consider the use of hop acids as a processing aid. Finally, the dosing of isomerized hop acids is cost effective.

EXAMPLES

The following Examples are intended to illustrate, but not limit, the scope of this invention.

15

EXAMPLE 1

Potassium hydroxide (30 kg) is added to a stirred solution of beta fraction (containing 55 % α -acids) and water (900 liters) at 70°C until pH 10.5 is reached. After stirring for two hours, the oil and aqueous layers are allowed to separate. The aqueous layer is removed and cooled to 5°C. The precipitate is removed to yield the aqueous β -acid solution (1000 liters), which is dosed into the process medium of a milk production after pasteurization to control the growth of heat resistant spores or any other thermophilic bacteria which are not controlled by pasteurization.

EXAMPLE 2

A solution is made as in Example 1, which is dosed to aqueous milk products in order to control bacteria such as lactic acid bacteria which would cause undesired fermentation.

30

EXAMPLE 3

A solution is created as in example 1 and added to vegetables in aqueous solution before they are packed in tins. Heat resistant spores and bacteria resulting from them causing a deterioration of the flavor are effectively controlled. As a result the shelf life of such products is extended.

EXAMPLE 4

An alkaline solution of isoalpha acid is dosed to the fermentation stage of a distillery in a concentration of about 10 to about 20 ppm. The temperature of the fermentation stage is below 30°C and the pH is below 6.

EXAMPLE 5

Two peristaltic pumps were calibrated using deionized water to deliver 20 ppm of isoalpha acids to two 28 °C molasses streams. One pump dosed ISOHOP® (a 30 %wt. solution of the potassium salt of isoalpha acid commercially available from Haas Hop Product, Inc.) to a dilute molasses stream, 20 brix (20% solids) feeding three yeast growing tanks. The other pump dosed ISOHOP® to a dilute molasses stream, 26 brix, feeding the 8 fermentors. These two streams ran constantly and the distillery ran essentially semi-continuous. Dip-tubes and valves were welded to the two pipes which delivered these two molasses streams. Figure 3 is a diagram showing how the concentrated molasses is first diluted to about 50 to about 55 brix and pH adjusted to about 6.2 at 60 °C. The dilutions took about 45-60 minutes and were further diluted downstream and cooled to 30 °C prior to ISOHOP® addition and introduction into the yeast growing tank and the fermentor. The concentrated molasses contains some bacteria, however, at 80 brix there is not enough water for the bacteria to grow, therefore, it remains dormant. Once diluted, however, the bacteria has an opportunity to grow. Therefore, ISOHOP® was introduced into the diluted molasses solution as soon as possible. Because the dilution tanks were small, dilutions were constantly being performed and sent forward to their appropriate tanks. It takes about 4 hours to fill each yeast growing tank, about 16 hours to fill the fermentation tank with molasses and

fermentation took an additional 48 hours.

The yeast growing solution and the “wine” from the fermentation were loaded with lactobacillus. Analytical analysis showed the bacteria count to be 3 million bacteria cells/mL. These two solutions were also analyzed for residual sugar, alcohol yield and total organic acids, such as lactic acid, acetic acid etc.

Figure 4 is a diagram demonstrating the growth of yeast in the yeast growing tanks. At time zero there were two yeast growing tanks which hold a total volume of 100 HL each. Each tank contained about 40 HL of yeast and molasses feed and was constantly aerated. The molasses feed was constantly added to two yeast growing tanks at a flow rate of 20 HL per hour. It takes four hours to fill these two tanks to a volume of 80 HL each. After each tank reached a total volume of 80 HL, one tank was transferred to an empty fermentor while half of the other tank was pumped into the third empty yeast growing tank to continue the process of growing more yeast.

After the 80 HL of yeast solution was sent to an empty fermentor 120 HL of molasses ~ 26 brix was added to this fermentation tank. The addition of this molasses solution took about 16 hours and 48 hours after molasses addition the fermentation was complete. The combined 200 HL of molasses/yeast/alcohol etc was pumped to the distillation towers to isolate the ethanol.

After dosing for about 20 hours 15 ppm of ISOHOP® was added to the molasses feed going into the fermentor and about 13 ppm of ISOHOP® was added to the molasses feeding the yeast solution. Microscopic inspection of the yeast solution and fermentation solutions indicated a lowering of the bacteria.

40 hours after dosing it was clear that the bacteria count in the yeast growing solution was down significantly and the fermenting solution looked about normal. The first fermentation with ISOHOP® was complete. Samples of the wine were analyzed which showed that the amount of organic acid was reduced by about 0.4% vs. before ISOHOP® addition. The residual sugar in the wine measured 130 ppm and distillation of this material produced a normal ethanol yield. The yeast cells in the fermentor showed no flocculation indicating that bacteria contamination was low.

After three days of dosing 11 ppm of ISOHOP® into the yeast growing solution

and 15 ppm into the fermentor, microscopic inspection of the yeast growing showed little to no lactobacillus bacteria and the fermentation solutions looked normal. Based on the fact that the antibiotic Virginiamycin reduces the bacteria count by only 50% it appears that ISOHOP® works better than Virginiamycin.

5 On day four dosing of ISOHOP® into the fermentor stopped and 11 ppm of ISOHOP® was dosed into the yeast growing solution for the next 48 hours. This 11 ppm solution was diluted to 4 ppm once the molasses solution was added to the fermentor. Analysis of the yeast growing solution showed little to no lactobacillus and only few cocci bacteria and the fermentor solutions showed little to no difference between those
10 fermentations which had 15 ppm of ISOHOP® and those currently receiving 4 ppm ISOHOP® via the yeast growing tank.

WHAT IS CLAIMED IS:

1. An improved process for controlling micro-organisms in an aqueous process medium comprising adding a hop acid, characterized in, that the process
5 comprises:
 - (a) dissolving the hop acid in an aqueous alkaline medium to form an aqueous alkaline hop acid solution; and
 - (b) adding an effective amount of the aqueous hop acid solution to the aqueous
10 process medium, wherein the pH of the aqueous hop acid solution is higher than the pH of the process medium and wherein the hop acid is in free acid form.
2. A process according to claim 1, wherein the aqueous alkaline hop acid solution is added to the process medium continuously.
15
3. A process according to claim 1, wherein the aqueous alkaline hop acid solution contains from about 2 to about 40 wt. % of hop acid.
4. A process according to claim 1, wherein the pH of the aqueous alkaline hop acid
20 solution ranges from about 7.5 to about 13.0.
5. A process according to claim 1, wherein the hop acid is a natural hop acid or derivative thereof; an isomerized hop acid or derivative thereof; or mixtures thereof.
25
6. A process according to claim 5, wherein the natural hop acid or derivative thereof is alpha acid, beta acid, tetrahydroalpha acid, hexahydrobeta acid, or mixtures thereof.

7. A process according to claim 5, wherein the isomerized hop acid or derivative thereof is isoalpha acid, rhoisoalpha acid, tetrahydroisoalpha acid, hexahydroisoalpha acid, or mixtures thereof.
- 5 8. A process according to claim 1, wherein the alkaline medium comprises from about 1 to about 5 wt. % of potassium hydroxide, sodium hydroxide or mixtures thereof.
9. A process according claim 1, wherein the temperature of the process medium is
10 lower than 100°C.
10. A process according to claim 1, wherein the concentrations of the hop acid within the process medium is in the range of 0.1 - 50 ppm.
- 15 11. A process according to claim 1, wherein the process medium is selected from a fermentation medium in the course of the preparation of spirits or wine-containing beverages; a fermentation medium in the course of the dairy production; a process medium in a juice production process; a process medium in a yeast production process, a process medium in a detergent or cosmetic production
20 process; a process medium in the processing of aqueous solutions of tinned foods.
12. A process according to claim 1, wherein the aqueous alkaline solution of hop acid is prepared according to the following process:
- a) heating an aqueous medium;
- 25 b) adding a hop acid to the heated aqueous medium wherein the final concentration of the hop acid is within a predefined range of concentration;
- c) adding an alkaline medium to obtain a pre-defined pH;
- d) mixing the alkaline medium with the hop acid aqueous medium;

- e) keeping the mixture in a raised temperature range within a pre-defined time period;
- f) separating the solution of hop acid from the mixture; and
- g) cooling the solution of hop acid to a temperature below about 20°C.

5

13. A process according to claim 12, wherein the solution of hop acid is cooled to a temperature below 10°C.
14. An improved process for controlling the bacterial growth in a distillery comprising a yeast growing tank and a fermentor tank containing a fermentable solution, the improvement comprising adding to the yeast and fermentor streams of the distillery an effective antibacterial amount of an isoalpha acid or derivative thereof.
15. A process according to claim 14 wherein, the isomerized hop acid or derivative thereof is isoalpha acid, rhoisoalpha acid, tetrahydroisoalpha acid, hexahydroisoalpha acid, or mixtures thereof.
16. A process according to claim 14 wherein, the fermentable solution is stored as a concentrate and the isomerized hop acid is dosed into the yeast or fermentor feed streams immediately after dilution as an aqueous solution.
17. A process according to claim 16 wherein, the pH of the aqueous solution comprising the isomerized hop acid is greater than the pH of the yeast or fermentor streams.
18. A process according to claim 14 wherein, the concentration of isomerized hop acid or derivative thereof in the yeast and fermentor streams ranges from about 1 to about 20 ppm.
19. A process according to claim 18 wherein, the concentration of isomerized hop acid or derivative thereof in the yeast and fermentor streams ranges from about 2 to about 4 ppm.

1/4

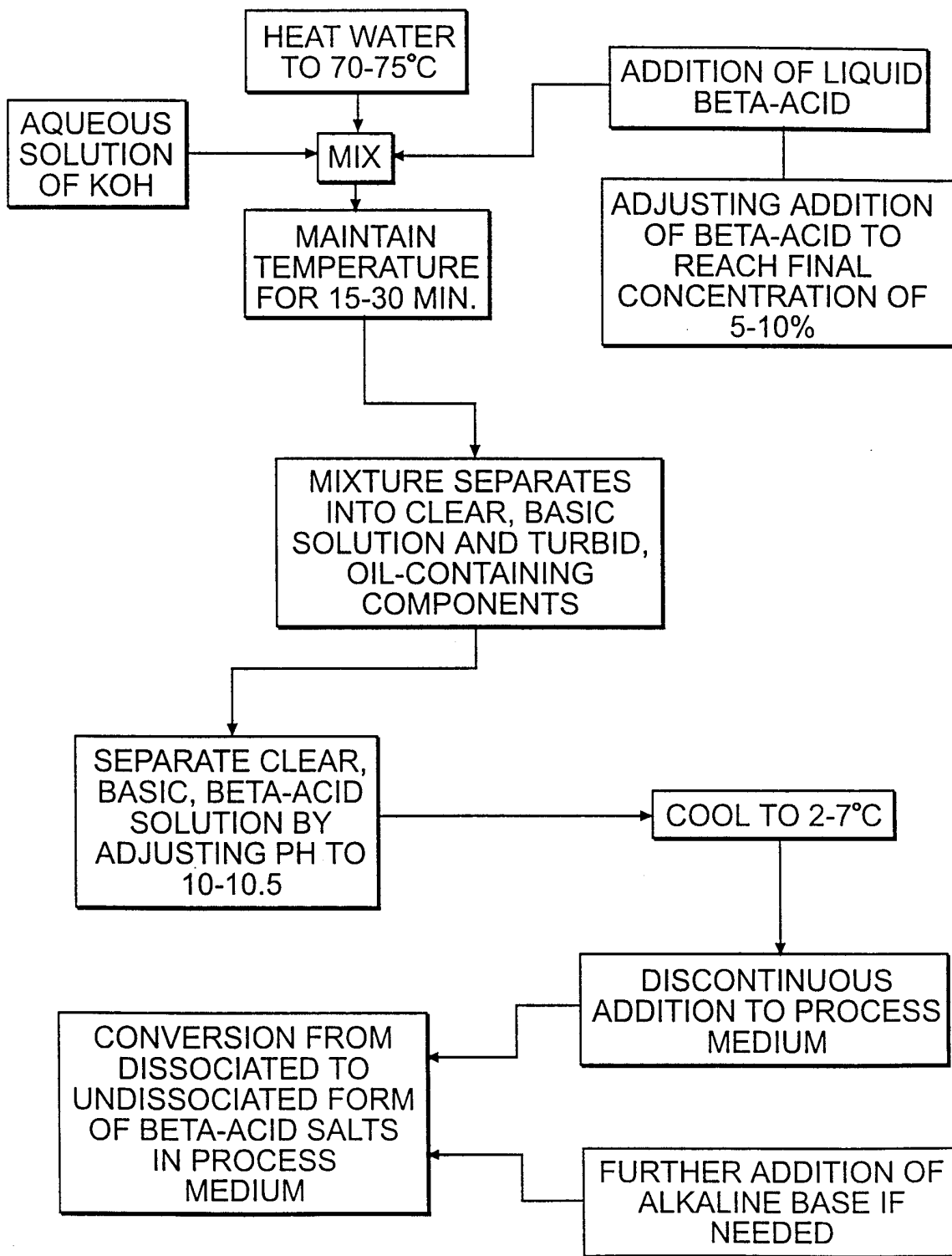

FIG. 1

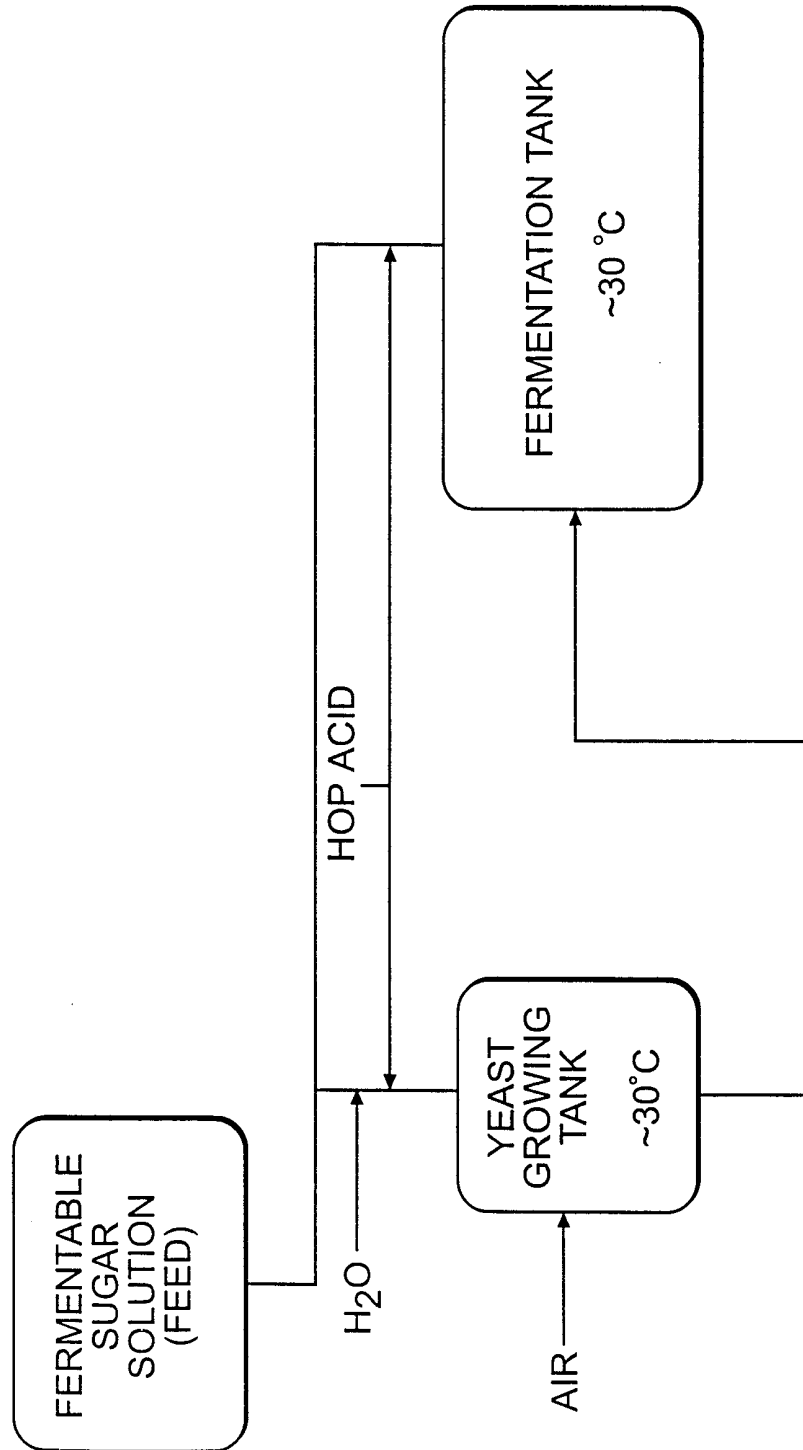

FIG. 2

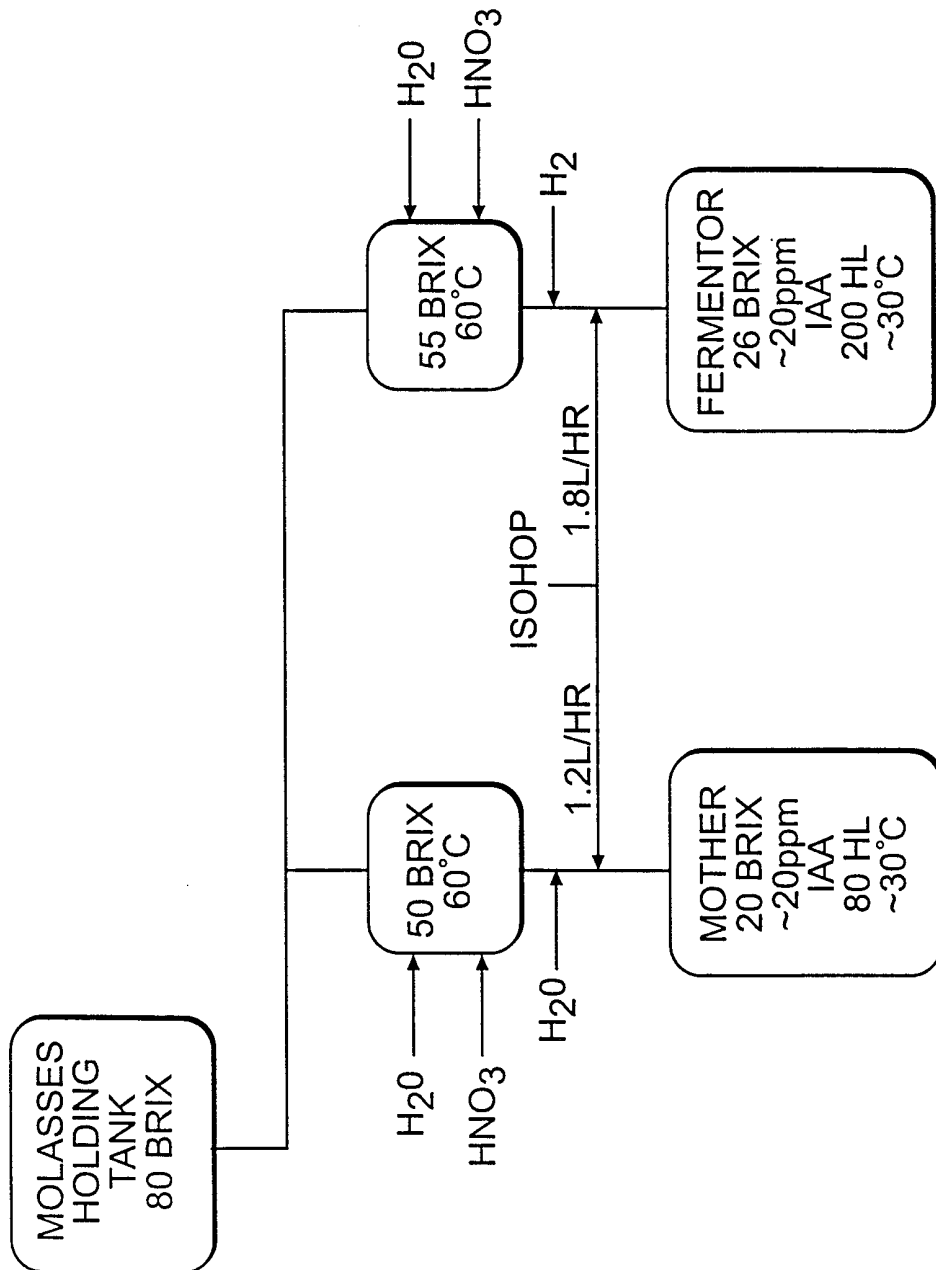

FIG. 3

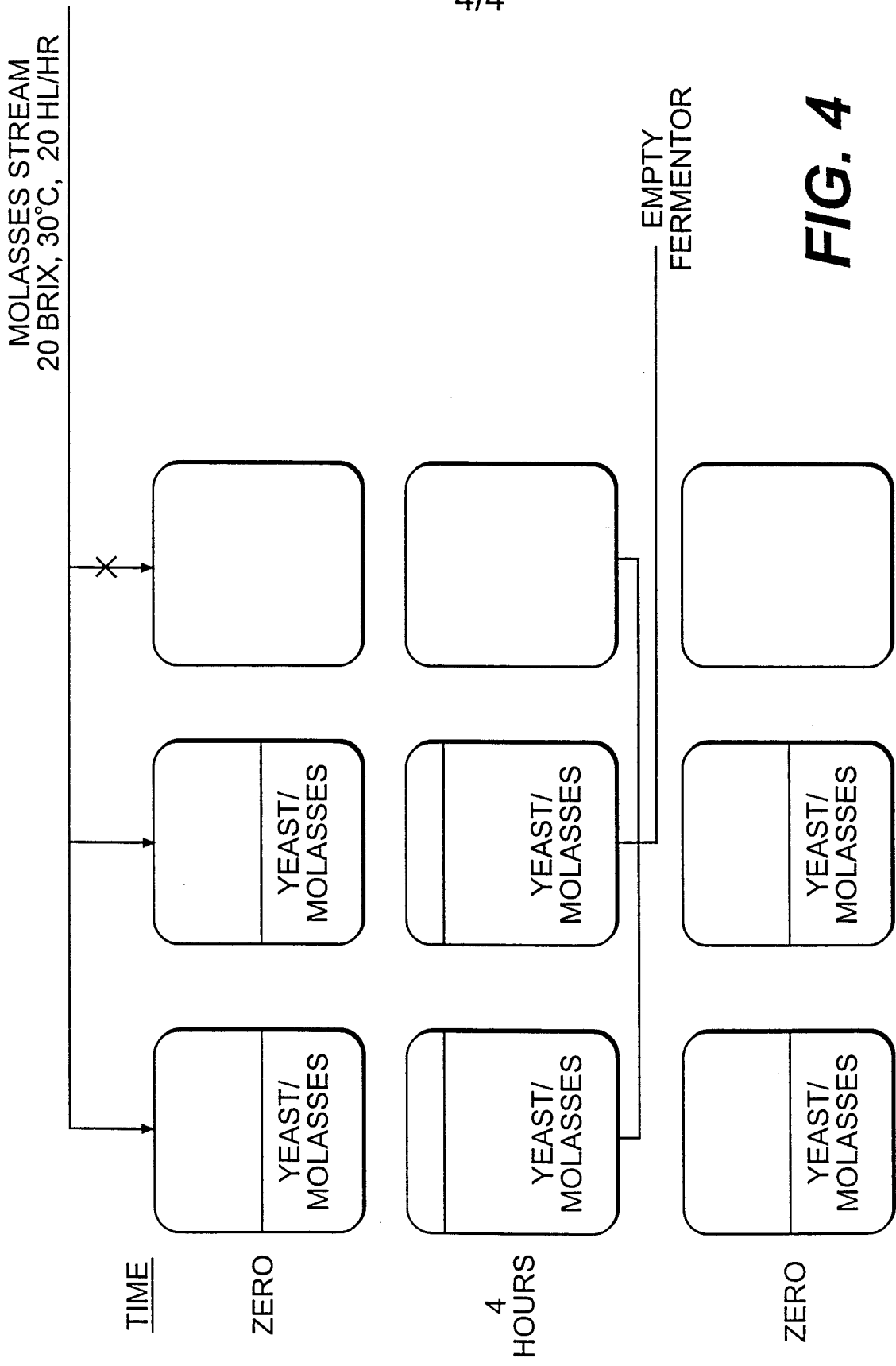

FIG. 4

INTERNATIONAL SEARCH REPORT

Inte onal Application No
PCT/US 00/05624

A. CLASSIFICATION OF SUBJECT MATTER
 IPC 7 C13D1/00 A23L3/3508 C12H1/00

According to International Patent Classification (IPC) or to both national classification and IPC

B. FIELDS SEARCHED

Minimum documentation searched (classification system followed by classification symbols)
 IPC 7 C13D A23L C12H C12C

Documentation searched other than minimum documentation to the extent that such documents are included in the fields searched

Electronic data base consulted during the international search (name of data base and, where practical, search terms used)

C. DOCUMENTS CONSIDERED TO BE RELEVANT

Category °	Citation of document, with indication, where appropriate, of the relevant passages	Relevant to claim No.
X A	WO 97 33971 A (KALAMAZOO HOLDINGS INC) 18 September 1997 (1997-09-18) page 3, line 34 -page 5, line 11 page 5, line 31 -page 6, line 28 page 7, line 4-33 claims 1,4-7,10,17,18; examples 1-5,7-9 ---	1,3-5,7, 9-12 14-19
X A	US 5 166 449 A (TODD JR PAUL H ET AL) 24 November 1992 (1992-11-24) column 1, line 16-23 column 2, line 21-29,35 -column 3, line 23,43-46 examples 5,6 --- -/---	1,3-6,8, 9,11 14-19

Further documents are listed in the continuation of box C. Patent family members are listed in annex.

° Special categories of cited documents :

"A" document defining the general state of the art which is not considered to be of particular relevance "E" earlier document but published on or after the international filing date "L" document which may throw doubts on priority claim(s) or which is cited to establish the publication date of another citation or other special reason (as specified) "O" document referring to an oral disclosure, use, exhibition or other means "P" document published prior to the international filing date but later than the priority date claimed	"T" later document published after the international filing date or priority date and not in conflict with the application but cited to understand the principle or theory underlying the invention "X" document of particular relevance; the claimed invention cannot be considered novel or cannot be considered to involve an inventive step when the document is taken alone "Y" document of particular relevance; the claimed invention cannot be considered to involve an inventive step when the document is combined with one or more other such documents, such combination being obvious to a person skilled in the art. "&" document member of the same patent family
---	---

Date of the actual completion of the international search 31 May 2000	Date of mailing of the international search report 28/06/2000
---	---

Name and mailing address of the ISA European Patent Office, P.B. 5818 Patentlaan 2 NL - 2280 HV Rijswijk Tel. (+31-70) 340-2040, Tx. 31 651 epo nl, Fax: (+31-70) 340-3016	Authorized officer Tallgren, A
--	--

INTERNATIONAL SEARCH REPORT

International Application No

PCT/US 00/05624

C.(Continuation) DOCUMENTS CONSIDERED TO BE RELEVANT		
Category °	Citation of document, with indication, where appropriate, of the relevant passages	Relevant to claim No.
X A	EP 0 339 147 A (MILLER BREWING) 2 November 1989 (1989-11-02) page 1, line 1-12,17-21 page 2, line 34-49 examples 2,3 -----	1-3,6,7, 11-13 14-19
X A	GB 1 058 975 A (STEINER INC) ----- page 1, line 76 -page 2, line 60 page 2, line 107 -page 3, line 31 page 7, line 53-87 page 8, line 14-20 claims 1,2,10,12,14-17,22,23,29; examples 1-3 -----	1,2,4-7, 9,11-13 14-19
X	WO 94 09759 A (BIO TECH RESOURCES) 11 May 1994 (1994-05-11) page 1, line 30-34 page 2, line 36 -page 3, line 12,21-29 examples 3,4 -----	1,4-6,9, 11

INTERNATIONAL SEARCH REPORT

information on patent family members

International Application No

PCT/US 00/05624

Patent document cited in search report	Publication date	Patent family member(s)	Publication date
WO 9733971 A	18-09-1997	AU 2212397 A	01-10-1997
US 5166449 A	24-11-1992	US 4918240 A US 5082975 A AU 619143 B AU 3958889 A BE 1004239 A CA 1315804 A DE 3926332 A GB 2222160 A,B NL 8902050 A ZA 8906186 A	17-04-1990 21-01-1992 16-01-1992 15-02-1990 20-10-1992 06-04-1993 22-02-1990 28-02-1990 01-03-1990 24-04-1991
EP 0339147 A	02-11-1989	AT 102245 T DE 3888165 D DE 3888165 T US 4759941 A	15-03-1994 07-04-1994 21-07-1994 26-07-1988
GB 1058975 A		DE 1442159 A SE 319740 B US 3364265 A	11-12-1969 26-01-1970 16-01-1968
WO 9409759 A	11-05-1994	US 5286506 A AU 5411194 A CA 2147646 A,C EP 0668756 A JP 2731632 B JP 8502887 T KR 153063 B NZ 257479 A	15-02-1994 24-05-1994 11-05-1994 30-08-1995 25-03-1998 02-04-1996 01-10-1998 21-12-1995