

(19) World Intellectual Property Organization
International Bureau



(43) International Publication Date
18 June 2009 (18.06.2009)

PCT

(10) International Publication Number
WO 2009/076038 A4

- (51) **International Patent Classification:**
F16K 17/04 (2006.01) F16K 1/36 (2006.01)
F16K 1/52 (2006.01)
- (21) **International Application Number:**
PCT/US2008/084313
- (22) **International Filing Date:**
21 November 2008 (21.11.2008)
- (25) **Filing Language:** English
- (26) **Publication Language:** English
- (30) **Priority Data:**
11/951,550 6 December 2007 (06.12.2007) US
- (71) **Applicant (for all designated States except US):** **BAKER HUGHES INCORPORATED** [US/US]; P.O. Box 4740, Houston, TX 77210-4740 (US).
- (72) **Inventors; and**
- (75) **Inventors/Applicants (for US only):** **GAUDETTE, Sean, L.** [US/US]; 23322 Dunhill Court, Katy, TX 77494 (US). **HOLMES, Kevin, C.** [US/US]; 4110 Whitman Street, Houston, TX 77027 (US).
- (74) **Agents:** **DUPHORNE, Darin, H.** et al.; Baker Oil Tools Division - Baker Hughes Inc., Division Intellectual Property Counsel, P.O. Box 4740, Houston, TX 77210-4740 (US).
- (81) **Designated States (unless otherwise indicated, for every kind of national protection available):** AE, AG, AL, AM,

AO, AT, AU, AZ, BA, BB, BG, BH, BR, BW, BY, BZ, CA, CH, CN, CO, CR, CU, CZ, DE, DK, DM, DO, DZ, EC, EE, EG, ES, FI, GB, GD, GE, GH, GM, GT, HN, HR, HU, ID, IL, IN, IS, JP, KE, KG, KM, KN, KP, KR, KZ, LA, LC, LK, LR, LS, LT, LU, LY, MA, MD, ME, MG, MK, MN, MW, MX, MY, MZ, NA, NG, NI, NO, NZ, OM, PG, PH, PL, PT, RO, RS, RU, SC, SD, SE, SG, SK, SL, SM, ST, SV, SY, TJ, TM, TN, TR, TT, TZ, UA, UG, US, UZ, VC, VN, ZA, ZM, ZW.

(84) **Designated States (unless otherwise indicated, for every kind of regional protection available):** ARIPO (BW, GH, GM, KE, LS, MW, MZ, NA, SD, SL, SZ, TZ, UG, ZM, ZW), Eurasian (AM, AZ, BY, KG, KZ, MD, RU, TJ, TM), European (AT, BE, BG, CH, CY, CZ, DE, DK, EE, ES, FI, FR, GB, GR, HR, HU, IE, IS, IT, LT, LU, LV, MC, MT, NL, NO, PL, PT, RO, SE, SI, SK, TR), OAPI (BF, BJ, CF, CG, CI, CM, GA, GN, GQ, GW, ML, MR, NE, SN, TD, TG).

Published:

- with international search report (Art. 21(3))
- with amended claims (Art. 19(1))

(88) **Date of publication of the international search report:**
3 September 2009

Date of publication of the amended claims: 22 October 2009

(54) **Title:** VALVE RESPONSIVE TO FLUID PROPERTIES

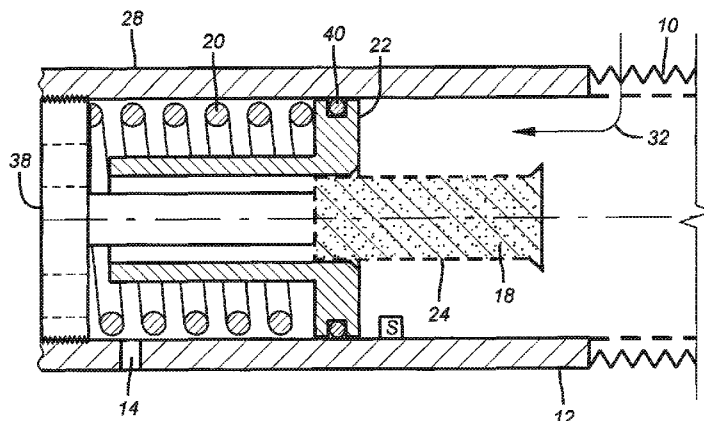

FIG. 3

(57) **Abstract:** A valve for downhole use has the ability to throttle between fully open and closed and is fully variable in positions in between. The valve is preferably responsive to flowing fluid viscosity and uses a three dimensional flow through restrictor in combination with a relatively movable cover. At a given flow, a higher viscosity fluid will create a greater relative movement and make it possible for flowing fluid to bypass more of the flow through member. In a particular application involving production from a zone, an array of such valves can allow more production where the viscosity is higher and less production where the viscosity drops due to, for example, water production.



WO 2009/076038 A4

AMENDED CLAIMS**received by the International Bureau on 25 August 2009 (25.08.2009)**

1. A valve assembly for subterranean use, comprising:
 - at least one housing;
 - at least one screen mounted to said housing;
 - a pourous valve member in said housing for regulating flow that has passed through said screen therethrough, said flow passing through said valve member in multi-planar intersecting axes;
 - relative movement between said valve member and said housing regulates flow in at least one of said directions, the amount of said relative movement is automatically responsive to changes in a physical property of said fluid.
2. The assembly of claim 1, wherein:
 - flow in one of said directions is restricted independently of flow in another direction.
3. Canceled
4. Canceled
5. The assembly of claim 1, wherein:
 - said physical property comprises viscosity.
6. The assembly of claim 1, wherein:
 - said valve member comprises a longitudinal axis and an elongated exterior surface surrounding said axis: and
 - said directions for said flow comprise flow paths extending substantially along said longitudinal axis and other paths entering said valve member through said exterior surface.
7. The assembly of claim 6, wherein:
 - said relative movement selectively covers said exterior surface.
8. The assembly of claim 7, wherein:
 - the amount of said relative movement for a predetermined flow rate is determined by a physical property of the flowing fluid.
9. The assembly of claim 8, wherein:
 - said relative movement is resisted by bias force acting in a direction to cover said exterior surface.
10. The assembly of claim 9, wherein:
 - said physical property comprises viscosity such that the force exerted by said flow against said bias is increased to expose more of said exterior surface when the viscosity rises for

a predetermined flow rate and decreases to expose less of said exterior surface for that flow rate when the viscosity decreases.

11. The assembly of claim 10, wherein:

said relative movement occurs without measurement of said viscosity.

12. The assembly of claim 11, wherein:

said valve member increasing resistance to flow therethrough from relative movement induced by flow of water as opposed to a more viscous hydrocarbon.

13. The assembly of claim 12, wherein:

said assembly comprises a plurality of valves situated adjacent spaced openings in a base pipe of a screen assembly;

said valves that experience a reduction in viscosity of the flow increasing resistance to flow as compared to other valves where the viscosity of the flow is higher.

14. The assembly of claim 13, wherein:

said valve members having an impervious inlet end surface adjacent said exterior surface for selectively restricting flow through said valve member when said exterior surface is covered by said housing.

15. The assembly of claim 1, wherein:

said valve member is movable with respect to said housing.

16. The assembly of claim 1, wherein:

a portion of said housing is movable with respect to a stationary valve member.

17. Canceled

18. The assembly of claim 1, wherein:

said valve member is made of a pack of beads or a sintered metal.

19. The assembly of claim 18, wherein:

said valve member is one of a cylindrical or annular shape.

20. The assembly of claim 3, wherein:

said assembly further comprises a control system to sense a physical property of said flow and create relative movement between said valve member and said housing responsive to said sensed physical property.