



June 27, 1939.

A. EFRON

2,164,133

FILING BOX

Filed Nov. 16, 1938

2 Sheets-Sheet 2

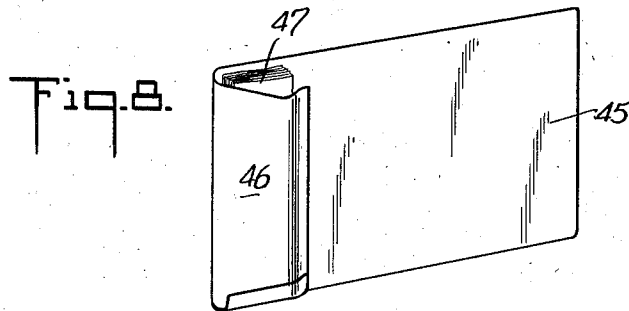
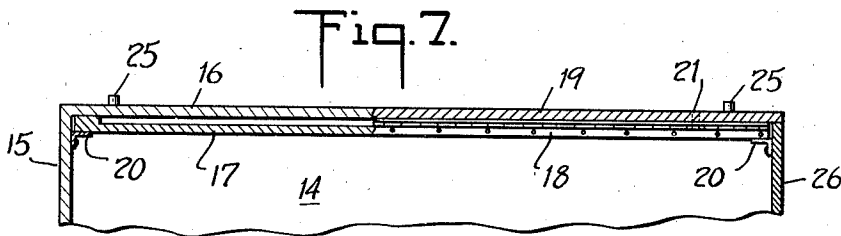
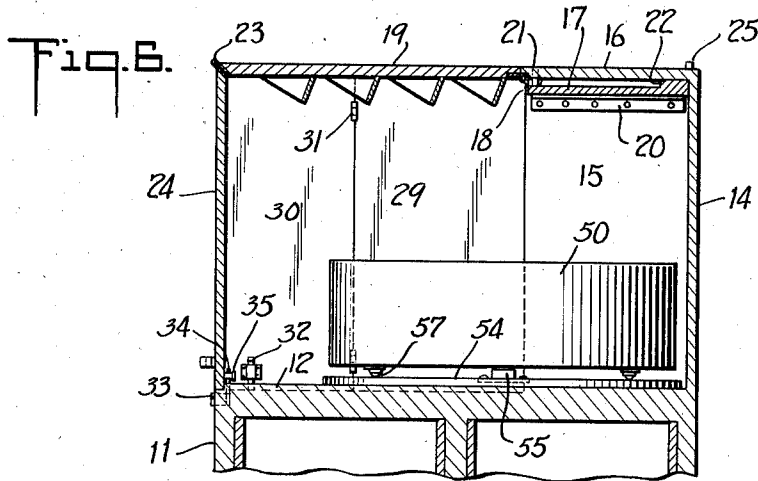

INVENTOR  
ALEXANDER EFRON  
BY  
*Bluck & Breitenfeld*  
ATTORNEYS

# UNITED STATES PATENT OFFICE

2,164,133

## FILING BOX

Alexander Efron, New York, N. Y., assignor to  
Checkmaster Plan, Inc., New York, N. Y., a cor-  
poration of New York

Application November 16, 1938, Serial No. 240,607

9 Claims. (Cl. 45—3)

My present invention relates generally to filing devices and has particular reference to a new type of filing box and filing cabinet.

The subject matter of this invention is primarily intended for use in banks, and the general object of the invention is not only to provide an efficient and compact storage space for ledger sheets, statement sheets, and vouchers, but also to provide a group of elements which are so combined and associated with one another that the bookkeeping procedure is greatly facilitated and simplified.

It will be understood however that the invention is not strictly limited to banking, and that its features are equally applicable to other institutions, such as department stores or the like, wherever the bookkeeping involves a correlation between vouchers and postings onto ledger or statement sheets.

The bookkeeping which is necessary in conducting a conventional banking business is typical of that which is facilitated and simplified by means of the present invention. Briefly, this involves the accumulation and sorting of the checks that are drawn by the bank's customers during a certain time interval, the posting of suitable corresponding entries onto each customer's ledger sheet and statement sheet, and the ultimate submission to each customer of a statement sheet, together with the vouchers to which the entries on the statement appertain.

This work must not only be painstaking, accurate and timely but it must be carried on in a manner which safeguards all the records, especially the vouchers, against fire, theft and misplacement. This work, as usually practiced, is quite cumbersome, inefficient, and relatively expensive, and frequently involves as many as five or more separate sorting and filing instrumentalities.

It is a general object of my present invention to simplify this procedure, to minimize the likelihood of errors and delays, to unite the sorting and filing instrumentalities into a compact unit, and generally to increase the efficiency and reduce the expense of conducting a business of the character described.

One feature of my invention lies in combining into a single unit, the means for filing a group of ledger sheets, a corresponding group of statement sheets, and an accumulation of vouchers that relate to the entries on such sheets.

Another feature of the invention lies in the provision of an improved type of voucher-sorting rack, and while this rack has novel and useful

characteristics, independent of the filing unit as a whole, my invention provides for an efficient union of this rack with the filing means.

Briefly, a filing cabinet of the present character includes a supporting base, at least one filing box accommodated on top of the base, an enclosure for the space above the base, the enclosure comprising side walls and a top wall, and means for moving said walls aside so as to uncover the filing box and the space above the base, so that it is freely accessible.

In accordance with my invention, the supporting base accommodates within itself at least one additional filing compartment and a closure therefor; and I provide a common locking means for the entire unit so that everything within the unit is safely enclosed and protected during non-working periods.

In carrying out the bookkeeping procedure, I prefer to employ statement sheets of the character illustrated and described in my earlier patent, Number 2,134,112, in which each statement sheet is provided with a pocket adapted to accommodate a bundle of vouchers appertaining to the entries on the statement sheet. However, I have found that the use of these statement sheets presents certain difficulties when ordinary rectangular filing boxes are sought to be used, because the bundle of vouchers makes the sheet of unequal thickness, and makes it unfeasible to stack such sheets, one behind the other, in an ordinary rectangular filing box.

It is therefore a further feature of my present invention to provide a novel type of filing box especially intended for use with statement sheets of this character. Here too, while the novel characteristics of this box make it independently useful, the present invention provides a means for efficiently uniting this particular filing box with the other elements of a unitary structure.

The new filing box consists essentially of a bottom wall, a substantially circular side wall, and a series of upright partitions which extend outwardly from the midportion of the box, each partition being arranged in a plane whose intersection with the bottom wall is tangential to a circle concentric with the center of the box.

Various other features of the invention are illustrated in the accompanying drawings and will be more fully appreciated after this specification has been read.

I achieve the foregoing objects and such other objects as may hereinafter appear or be pointed

out, in the manner illustratively exemplified in the accompanying drawings in which:

Figure 1 is a perspective view of a conventional filing cabinet of the present character;

5 Figure 2 is a perspective view of the same cabinet, on a larger scale, showing the cabinet partially open for use;

10 Figure 3 is a fragmentary cross-sectional view taken substantially along the line 3—3 of Figure 2 showing some of the details of the voucher-sorting rack;

Figure 4 is a plan view of the new filing box by itself;

15 Figure 5 is a cross-sectional view taken substantially along the line 5—5 of Figure 4;

Figure 6 is a fragmentary cross-sectional view taken substantially along the line 6—6 of Figure 1;

20 Figure 7 is a fragmentary cross-sectional view taken substantially along the line 7—7 of Figure 1; and

Figure 8 is a perspective view, from the rear, of a statement sheet adapted to be accommodated within the box of Figures 4 and 5.

25 The cabinet which I have chosen to illustrate is a substantially rectangular structure preferably mounted on rollers 10, to permit it to be moved about. It is preferably composed of metal or fire-resistant wood, and it will be understood that this and other various structural details, well known per se to those skilled in the art, are not herein illustrated nor described.

30 The supporting base 11 has a permanently closed top wall 12. At the front and along portions of the sides this wall provides a shoulder 13 which cooperates with the movable walls presently to be described. The rear wall of the base 11, designated by the reference numeral 14, extends above the top wall 12, and joins at the sides and top with the permanent side wall portions 15 and the permanent top wall portion 16.

35 Slidably mounted beneath the top wall portion 16 is a supporting strip 17 whose forward edge carries a hinge 18 to which the movable top wall 19 is attached. The parts are so arranged that when the device is entirely closed, the movable top wall 19 forms a substantially smooth forward continuation of the permanent top wall 16.

40 The slidability of the strip 17 is preferably provided for by mounting it upon brackets 20 secured to the permanent side walls 15. The rearward sliding of the strip 17 is limited by the rear wall 14, as shown in Figure 6; and the forward sliding is preferably limited in extent by stop pins 21 carried by the permanent top wall 16 and positioned to be encountered by the shoulder 22 near the rear end of the strip 17, as shown most clearly in Figure 3.

45 At the forward edge of the top wall 19 I provide a hinge 23 which is attached to the wall 24 which is substantially parallel to the rear wall 14 when the device is closed. The hinge 23 is of such a character that the wall 24 may be swung upwardly and rearwardly to an extent sufficient to position it ultimately behind the top wall 19, and in bracing relation to the latter as shown most clearly in Figures 2 and 3. The hinge 18 is also of suitable character to permit this movement to be effected, and it will thus be observed that the top wall 19 can be swung upwardly and rearwardly into a rearwardly inclined position exposing the undersurface of the top wall 19. Preferably, pins or equivalent abutment means 25 are arranged near the rear edge of the top wall 16 to

brace the free edge of the wall 24 as shown in Figures 2 and 3.

5 The strip 17 permits the wall 19 to be moved forwardly and rearwardly through a limited distance when it is in the inclined position.

10 The walls 19 and 24 form part of an openable enclosure for the space above the top wall 12 of the supporting base 11. This space is enclosed, on top, by the wall 19, and is enclosed on the sides by the front side wall 24, and by two lateral side walls. One of these lateral side walls is shown most clearly in Figures 1 and 2 and consists of a rear portion 26 and a front portion 27. These portions are hinged together so that they be brought into superposed relation as shown in Figure 2, and the rear portion 26 is hinged as at 28 to the permanent side wall 15 so that the entire lateral side wall may be swung outwardly and rearwardly into the position shown in Figure 2.

20 The other lateral side wall is similar, and is shown most clearly in Figure 6, consisting of the rear portion 29 and the front portion 30, hinged together as at 31.

25 When the side walls are closed, their lower edges abut against the shoulder 13. To lock them in this closed position each of the side wall portions 27 and 30 is provided with a suitable bolt, or its equivalent as shown at 32 in Figure 6. This bolt may operate for example by manually lifting it when the device is to be opened and by manually pressing it down into a suitable recess in the top wall 12 when the device is closed. When the front side wall 24 is closed it is preferably locked by means of a key or similar locking instrumentality, and I have illustratively shown a lock barrel 33 whose rotation, under the action of a key, swings a hook 34 into locking and releasing relationship with respect to a pin 35 carried by the wall 24. Obviously, this is merely illustrative and any desired locking instrumentality, known per se, may be employed for this purpose.

30 It will be noted that the locking of the wall 24 makes access to the bolts 32 impossible. The lock 33, therefore, controls the opening and closing of the entire enclosure for the space above the supporting base 11. As a matter of fact, the lock 33 also controls the opening and closing of the one or more compartments accommodated within the supporting base itself.

35 For illustrative purposes, I have shown three filing compartments, in the form of drawers, in the right hand portion of the supporting base 11. The front walls of these drawers serve as closures for these compartments, and these front walls are designated by the reference numerals 36, 37 and 38. When the cabinet is closed, a bar 39 assumes the position shown in Figure 1, in which at least a portion of the bar lies over at least a portion of each drawer cover. This prevents opening of any of the drawers. The upper end of the bar has a turned-in flange which is accommodated in a recess in the wall 12, and this recess is covered by the lateral side wall portion 26 when the cabinet is closed.

40 In other words, the bar 39 serves as a lock which cannot be opened except when the walls 24, 27, 26, and the other walls constituting the main enclosure, are swung aside.

45 Merely as a matter of convenience, the bar 39 may be provided with a longitudinal slot 40 which engages over a pin 41 and allows the bar 39 to be swung out of its normal axis when it is lifted into the position of Figure 2. To hold the

5

10

15

20

25

30

35

40

45

50

55

60

65

70

75

bar 39 out of the way the slot 40 may be hooked over a pin 42 provided on the wall 26.

It will be understood that similar drawers or filing compartments may be arranged within the left hand portion of the supporting base 11, and that they may be provided with closures and with a locking means of similar character. It will also be obvious that these compartments need not be in the form of drawers, and may simply have a sliding or swinging door or closure which keeps them enclosed when not in use. Also, if these compartments or drawers are to be accessible from the front of the cabinet it will be understood that they may be caused to open through the front wall of the supporting base 11, without altering either their essential character or their mode of locking.

The top wall 12 of the supporting base 11 is adapted to accommodate one or more filing boxes, and I have illustratively shown an ordinary rectangular filing box 43, and a specially designed filing box which is shown most clearly in Figures 4 and 5. The box 43 is adapted to accommodate a series of ordinary rectangular ledger sheets 44, and may be of any suitable or desired type or construction, either loosely or permanently mounted on the wall 12.

The special filing box is intended to accommodate statement sheets of the character illustrated most clearly in Figure 8. In this figure I have shown the rear of a statement sheet 45, which is substantially rectangular and which has one edge turned back upon itself to define a pocket 46. This pocket is intended to accommodate one or more vouchers 47. The extra thickness which is thus produced at one end of the statement sheet makes it difficult to arrange these sheets, one behind the other in the ordinary rectangular filing box. A plurality of these units, however, as shown by the reference numeral 48 in Figure 4, may be conveniently and efficiently filed in a box which has a bottom wall 49 and a substantially circular side wall 50. Arranged within this box are a series of upright partitions 51 which extend outwardly from the midportion of the box, dividing the box into sectoral compartments in which the sheets may be accommodated with their bulky ends outward. Each partition is arranged in a plane and may for example consist of a substantially rectangular sheet of cardboard, metal or the like. Each partition is mounted for swinging movement about a horizontal axis and I have illustratively shown each partition hinged as at 52 to the bottom wall 49. The outer edge 53 of each partition is arranged close to but spaced from the side wall 50, and in this way the angle through which the partition may swing is limited by the contact of the edge 53 with the side wall 50. This is indicated by the dot-and-dash lines in Figure 4.

In accordance with my invention, each partition is arranged in a plane whose line of intersection with the bottom wall 49 is not accurately radial, but is deliberately tangential to a circle concentric with the center of the box. The reason for this is that the statement sheets do not assume accurate radial positions, as they rest one upon the other, but usually come to rest in the somewhat askew relation, indicated in Figure 4. By arranging the partitions in the particular manner shown and described the statement sheets are supported in convenient groups which may be readily thumbed through for the

purpose of withdrawing and subsequently replacing any selected sheet or sheets.

The partitions, as will be understood, are intended to facilitate the accommodation of the sheets in groups, when the box is less than full; i. e., each partition serves as a back support for the stack of sheets in the sectoral compartment in front of it and the swinging of the partitions is desirable to facilitate the procedure of thumbing through the sheets for withdrawal or replacement, or for the addition of new sheets.

The entire procedure is facilitated further by mounting the box upon a base 54 which may be in the form of a plate or disc loosely or permanently arranged on the wall 12. The base 54 is preferably provided with a socket 55 adapted to accommodate a removable pivot 56 which extends up through an opening in the center of the bottom wall 49. Also, the wall 49 is retained in spaced relation from the base 54 by antifric-tion means such as the rollers 57 supported in sockets carried on the underside of the wall 49. This permits the entire box to be freely rotated about its axis, and enables the operator to have easy access to all portions of the box. The removable pivot permits the operator, if it is deemed desirable, to separate the box completely from the base 54, and by removing the base 54 entirely the box may then be caused to roll freely in all directions upon the wall 12.

Obviously, this filing box, either with or without the base 54, is independently useful, and under certain circumstances it may be permanently or rotatively mounted on any other suitable type of stand or pedestal. The side wall need not necessarily be accurately circular and may obviously be of equivalent polygonal shape. The term "circular" as used in the appended claims is therefore intended to include within its scope any equivalent polygonal shape.

As an additional feature of the invention, I construct the top wall 19 as a panel adapted to serve as a voucher-sorting rack. With this object in view, I provide on the undersurface of the wall 19 (i. e., on the surface that is exposed when the wall is inclined as in Figure 2) a series of superposed horizontal voucher-sorting elements 57. Each element preferably comprises a flat strip of metal or the like arranged substantially perpendicular to the panel 19. On the upper surface of each strip I provide a series of substantially vertical partitions 58, preferably beveled rearwardly toward their free ends. These strips and partitions define a plurality of upwardly-open compartments which are purposely of such a shape and size that they may accommodate vouchers in visible face-up positions. It will be understood that the vouchers are not laid on the strip 57, but are laid directly upon the panel 19, with only their lower edges resting upon the strip 57.

This voucher-sorting rack may also find independent utility, as a convenient and efficient device for sorting vouchers or the like into a number of categories.

While the advantages of the present invention are believed to be obvious from the description hereinbefore given, it may be pertinent to stress the compactness and convenience of the present filing cabinet in the conduct of an ordinary commercial banking business. The entire cabinet is moved close to the operator who is seated at the posting machine. Such sorting of vouchers as he or she may be called upon to do may be accomplished with speed and accuracy upon the

sorting rack, and the movability of this rack permits the operator to bring it closer, or move it further away, to suit his or her convenience.

The vouchers, of course, serve as the basis for the bookkeeping entries to be made. Those entries which are to be made on ledger sheets are quickly taken care of by withdrawing the desired sheet from the box 43, placing it into the posting machine, making the entry, and then returning it to its place. The entries which are to be made on the statement sheets are conveniently made in a similar manner; and where the statement sheets are of the character illustrated in Figure 8, each voucher is thereupon immediately placed into the pocket carried by the corresponding statement sheet.

When there is no more room on a statement sheet for further entries, the sheet is removed, rolled or folded into a compact bundle and filed into one of the compartments in the supporting base.

At the end of a given period of time, each statement sheet is similarly rolled or folded into a compact bundle and delivered or mailed to the customer.

The foregoing procedure is one which has heretofore required a much more complicated series of steps, often necessitating the use of separate and widely spaced filing cabinets and the like, and much similar inefficiency.

During periods of non-use, the present cabinet is completely closed and locked with great ease, and the records are thus maintained in protected condition.

In general, it will be understood that changes in the details, herein described and illustrated for the purpose of explaining the nature of my invention, may be made by those skilled in the art without departing from the spirit and scope of the invention as expressed in the appended claims. It is, therefore, intended that these details be interpreted as illustrative, and not in a limiting sense.

Having thus described my invention, and illustrated its use, what I claim as new and desire to secure by Letters Patent is:

1. A filing box for rectangular sheets of the character described, comprising a bottom wall, a substantially circular side wall, a series of upright partitions extending outwardly from the midportion of the box, each partition being arranged in a plane whose line of intersection with the bottom wall is tangential to a circle concentric with the center of the box, and means for mounting each partition for swinging movement about a horizontal axis.

2. A filing box for rectangular sheets of the character described, comprising a bottom wall, a substantially circular side wall, a series of upright partitions extending outwardly from the midportion of the box, each partition being arranged in a plane whose line of intersection with the bottom wall is tangential to a circle concentric with the center of the box, means for mounting each partition for swinging movement about a horizontal axis, and means for limiting the angle through which the partition may swing.

3. A filing box for rectangular sheets of the character described, comprising a bottom wall, a substantially circular side wall, a series of upright partitions extending outwardly from the midportion of the box, each partition being arranged in a plane whose line of intersection with the bottom wall is tangential to a circle concentric with the center of the box, means for

mounting each partition for swinging movement about a horizontal axis, and each partition having its outer edge arranged close to but spaced from said side wall, whereby the angle through which the partition may swing is limited by the contact of said edge with the side wall.

4. A filing box for rectangular sheets of the character described, comprising a bottom wall, a substantially circular side wall, a series of upright partitions extending outwardly from the midportion of the box, each partition being arranged in a plane whose line of intersection with the bottom wall is tangential to a circle concentric with the center of the box, and means for mounting each partition for swinging movement about said line of intersection as an axis.

5. A filing box for rectangular sheets of the character described, comprising a bottom wall, a substantially circular side wall, a series of upright partitions extending outwardly from the midportion of the box, each partition being arranged in a plane whose line of intersection with the bottom wall is tangential to a circle concentric with the center of the box, and means for mounting each partition for swinging movement about said line of intersection as an axis, said means comprising a hinge securing the bottom edge of the partition to the bottom wall of the box.

6. A filing box for rectangular sheets of the character described, comprising a bottom wall, a substantially circular side wall, a series of upright partitions extending outwardly from the midportion of the box, each partition being arranged in a plane whose line of intersection with the bottom wall is tangential to a circle concentric with the center of the box, and means supporting said bottom wall for rotative movement about said center.

7. A filing box for rectangular sheets of the character described, comprising a bottom wall, a substantially circular side wall, a series of upright partitions extending outwardly from the midportion of the box, each partition being arranged in a plane whose line of intersection with the bottom wall is tangential to a circle concentric with the center of the box, and means supporting said bottom wall for rotative movement about said center, said means comprising a base, a pivot between the base and the bottom wall, and anti-friction means between the underside of the bottom wall and said base.

8. A filing box for rectangular sheets of the character described, comprising a bottom wall, a substantially circular side wall, a series of upright partitions extending outwardly from the midportion of the box, each partition being arranged in a plane whose line of intersection with the bottom wall is tangential to a circle concentric with the center of the box, and means supporting said bottom wall for rotative movement about said center, a base, an upstanding pivot pin extending from the base up through the center of the bottom wall, anti-friction means secured to the underside of the bottom wall and maintaining the latter spaced from said base, and means for removing said pivot pin to permit free movement of said box on said base.

9. A filing box for rectangular sheets having increased bulk at one end, comprising a bottom wall upon which the sheets are adapted to rest in substantially upright positions, a substantially circular side wall confining the sheets against outward radial movement, and a series of upright partitions extending outwardly from

the midportion of the box to divide the box into sectoral compartments in which the sheets may be accommodated with their bulky ends outward, each partition serving as a back support for the stack of sheets in the sectoral compartment in front of it, each partition being ar-

ranged in a plane whose intersection with the bottom wall is tangential to a circle concentric with the center of the box, thereby allowing for the shifting of the sheets out of true radial positions due to their bulky outer ends.

ALEXANDER EFRON.