

July 29, 1969

D. WILLIAMS ET AL

3,458,673

CRUSH SWITCH

Filed May 3, 1968

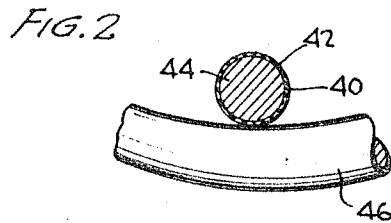
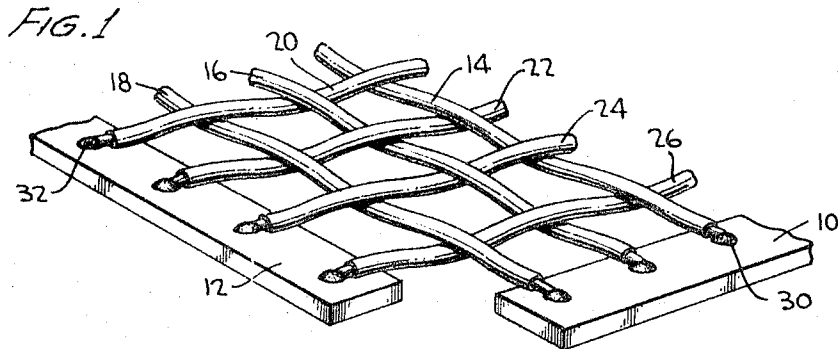

INVENTORS,
DAVID WILLIAMS
GEORGE K. LUCEY, JR.
BY Harry M. Saragovitz,
Edward J. Kelly, Herbert Berl
& Gerald L. Lett
ATTORNEYS

1

3,458,673

CRUSH SWITCH

David Williams, Bethesda, and George K. Lucey, Jr.,
Silver Spring, Md., assignors to the United States of
America as represented by the Secretary of the Army
Filed May 3, 1968, Ser. No. 726,353
Int. Cl. H01h 25/00; F42b 23/28
U.S. Cl. 200—61.08

4 Claims

ABSTRACT OF THE DISCLOSURE

A switch designed to operate upon deformation, the switch comprising vertical insulated wires interwoven with horizontal insulated wires. The ends of the vertical and horizontal wires are attached to connectors which are adapted to make contact with external circuits. When the switch is deformed, the insulation between the wires will be broken at least at one of the cross-over points between the vertical and horizontal wires and the wires will make electrical contact.

The invention described herein may be manufactured, used, and licensed by or for the Government for governmental purposes without the payment to me of any royalty thereon.

Background of the invention

One of the several well known methods of initiating detonation of a projectile is to use a crush switch to trigger the firing circuit. When the projectile in which the fuze employing a crush switch impacts with the ground, the switch becomes deformed causing switch closure. The switch closure is adapted to trigger the firing circuit.

Previous crush switches consist of a point contact sitting under a metal hat which is in the front of the projectile. When the fuze deforms on contact, some of the fuze structure pushes into the metal hat pushing it down against the metal point and closing the switch. The problem with this type of switch has been that the external leads to the switch broke up before the closure signal fired the detonator. Point contact switches are also sensitive to the fuze G forces and this sometimes leads to premature detonation. They are also expensive to manufacture and take up an undue amount of space within the projectile structure.

It is therefore an object of this invention to provide a crush switch which will operate on minimal deformation of the switch structure.

An additional object of the invention is to provide a crush switch that will not be sensitive to high gravity forces.

Another object of the invention is to provide a crush switch that is inexpensive, easy to manufacture and requires little space.

Summary of the invention

The crushable switch of my invention uses a screen type woven wire mesh as the basic switch assembly. The switch is made up of vertical insulated wires interwoven with horizontal insulated wires. The potential contact of switching points occur wherever a vertical wire crosses a horizontal wire. The area of the switch is large and is designed to extend over most of the cross-section of the forward part of the projectile.

Brief description of the drawings

The specific nature of the invention, as well as other objects, aspects, uses and advantages thereof, will clearly appear from the following description and from the accompanying drawing, in which:

2

FIGURE 1 illustrates a crush switch in accordance with my invention.

FIGURE 2 shows a cross-over point in the crush switch of FIGURE 1.

Description of the preferred embodiment

The switch shown in FIGURE 1 comprises vertical insulated wires 20, 22, 24 and 26 which are interwoven with horizontal insulated wires 14, 16 and 18. The horizontal wires are soldered to a connector 10 at points 30. The vertical wires are soldered to a connector 12 at points 32. The connectors are adapted for connection to external circuits. The potential contact or switching points occur wherever one of the vertical wires crosses a horizontal wire as shown in the drawing. The area covered by the woven wire mesh should normally extend over most of the cross-section of the fuze so that deformation will occur immediately upon impact. The switch, while shown in the drawing as having four vertical wires and three horizontal wires, may be expanded in both directions to include as many or as few wires as is necessary for the particular application. The spacing between wires can also be varied.

In FIGURE 2 a cross-over point is shown with a vertical wire 42 crossing a horizontal wire 46. The vertical wire 42 has a conductor portion 44 and an insulation 40 covering the conductor. In general the wire from which the switch is woven should be hard while the insulation should be soft or frangible. Upon deformation of the mesh the insulation will break away from the wires at some cross-over point and switch closure will occur between the vertical and horizontal wires at that point.

In this switch there are many cross-over points to insure that the closure signal fires the detonator before leads external to the switch break up. Additionally one can also perform logic functions with this switch by connecting the many wires leading from the switch so that the switch closures in different areas will initiate different events.

Because of the fact that the contact areas are already insulated the switch may also be foam potted. Closure of the switch will occur on extremely small movements and minimum deformation because of the fact that the spacing between the potential contact area is small; only about twice the original insulation on the wire. Additionally the switch will not be sensitive to G forces on the fuze but only to external deformation forces and fuze switch operation will have wide angle sensitivity.

The cost of assembling the switch described is minimal because conventional wire weaving machines may be utilized in their manufacture. The insulated wires may be manufactured by a standard anodizing method or a brittle lacquer method. Both processes are simple and inexpensive.

We claim as our invention:

1. An electrical crush switch which will close upon deformation comprising:

- (a) a first plurality of wires;
- (b) a second plurality of wires interwoven with and electrically insulated from said first plurality of wires, at least one wire of each of said first and second plurality of wires making contact with the other upon switch deformation;
- (c) said first and second plurality of wires each adapted to be connected to an external circuit respectively.

2. The switch of claim 1 wherein each wire of said first and second plurality of wires is covered with an electrical insulating material, the insulating material becoming broken upon switch deformation at least at one

3

cross-over point between said first and second plurality of wires so that electrical contact is made between said first and second plurality of wires.

3. The switch of claim 2 wherein said first and second plurality of wires have the ends of the wires connected to a first and second external circuit connector respectively.

4. The switch of claim 3 wherein the first and second plurality of wires each have a plurality of individual wires aligned in parallel, said first and second plurality of wires being at approximately right angles to each other.

5

10

2,587,458
3,396,252
3,398,397

4

References Cited

UNITED STATES PATENTS

2/1952 Fritts.
8/1968 Serizawa et al. ----- 200—86
8/1968 O'Connell ----- 200—86

H. O. JONES, Primary Examiner

U.S. Cl. X.R.

102—8