

(No Model.)

B. F. JONES.
MOP WRINGER.

No. 512,830.

Patented Jan. 16, 1894.

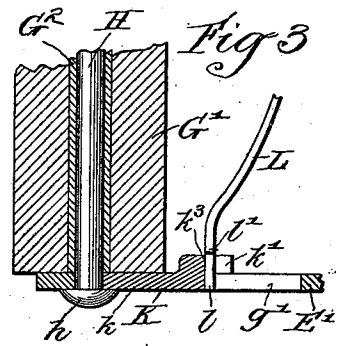
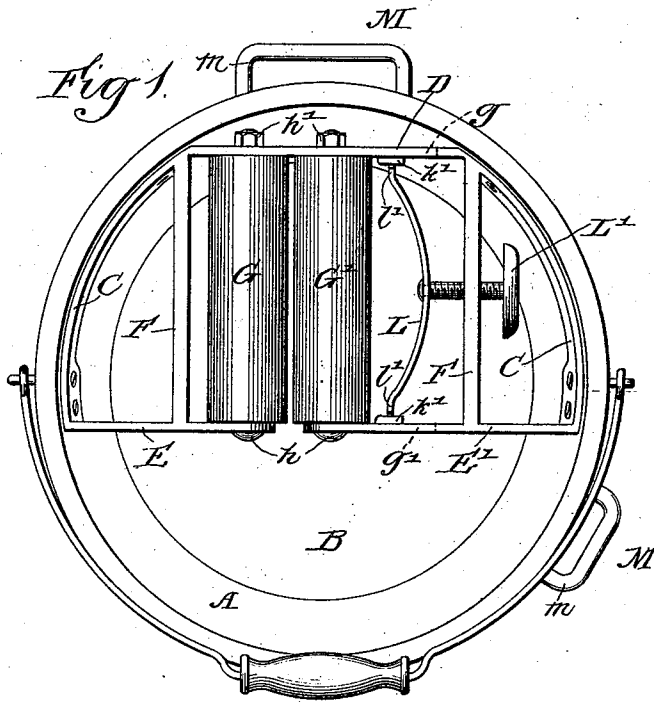

Fig 4

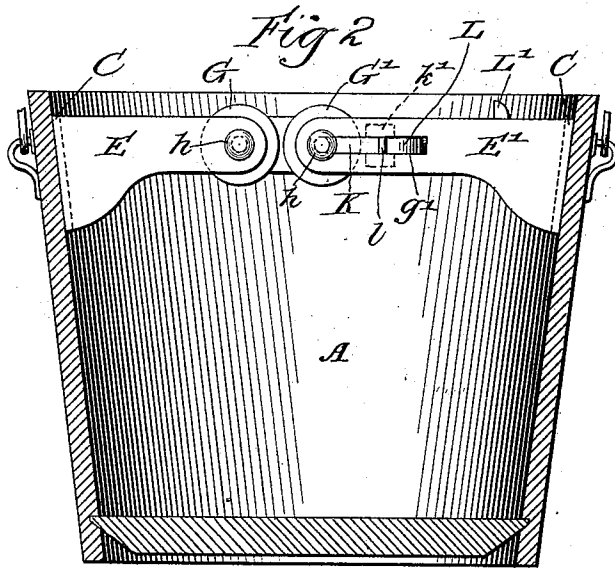
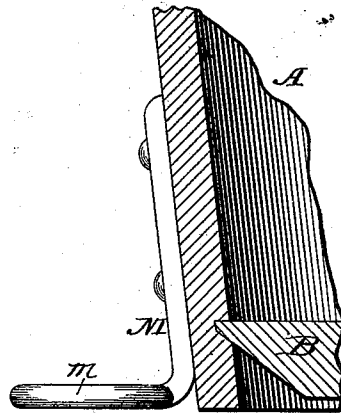
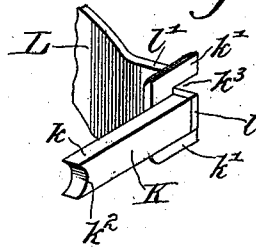

Fig 5.



Witnesses
 Wm. F. Heming
 Geo. M. Pheasant

Inventor
 Benjamin F. Jones
 By Joseph G. Robinson
 Atty.

UNITED STATES PATENT OFFICE.

BENJAMIN F. JONES, OF CHICAGO, ILLINOIS.

MOP-WRINGER.

SPECIFICATION forming part of Letters Patent No. 512,830, dated January 16, 1894.

Application filed May 2, 1893. Serial No. 472,700. (No model)

To all whom it may concern:

Be it known that I, BENJAMIN F. JONES, a citizen of the United States, residing at Chicago, in the county of Cook and State of Illinois, have invented certain new and useful Improvements in Mop-Wringers, of which the following is a specification.

This invention relates to mop-wringer attachments for pails in which two wringing rolls are supported within the pail itself in such manner that the mop may be introduced between one end of the pair; and it consists in a novel construction of the frame for supporting said rolls; in constructing the rolls, and in various combinations and details of construction hereinafter pointed out and claimed.

In the drawings: Figure 1 is a top plan view of a mop-pail provided with a wringing attachment embodying my invention. Fig. 2 is a vertical section through said pail on the correspondingly numbered line in the preceding figure. Fig. 3 is an enlarged detail of one of the wringing rollers in central, longitudinal section; Fig. 4, an enlarged detail showing one of the foot-rests; and Fig. 5, a perspective view of one of the sliding boxes or pillow-blocks.

A represents the mop-pail, in which is a wringer-frame preferably cast in a single piece, and comprising two curved end-bars or bands, C, adapted to the outline of the pail, that is to say, described on the same radius as the surface against which they are to sit and flaring to suit the flare of the pail. These end-bars are united at one side by the lateral bar, D, which is so short that it comes very close to one side of the pail. The opposite side of the frame, however, near the center of the pail, is represented by two opposing inseting arms or bars, E, E', parallel with the bar forming the short side and nearly, but not quite, meeting each other at their ends at a point adjacent to the transverse diameter of the pail. Cross-bars or braces, F, extend from the angle where the shorter lateral uniting bar meets the curved end-bars, to the inseting arms forming the opposite side, and hold them rigidly, and tie the frame against springing.

Mounted in fixed bearings in one of the inseting arms, E, and in the short lateral bar

is one of the wringing rollers, G, which extends parallel with the cross-bar or brace at that side of the pail, and the periphery of which projects slightly beyond the end of the inseting arm in which it has its bearing, as shown in the second figure of the drawings. The opposite arm is slotted longitudinally as at *g*, and a corresponding slot, *g'*, is formed in the side bar, E', to receive the axle of the yielding roller, G', the periphery of which also projects beyond this end-bar to meet the stationary roller, but not to come quite in contact with it.

The wringing-rollers it is proposed to form of wood, but as this is liable to warp, I bore them axially and in this central chamber secure a tightly fitting sleeve or brass, G², of suitable metal. Axle bolts, H, having heads, *h*, at one end and confining nuts, *h'*, at the other pass loosely through the sleeve and serve to connect the rollers to the frame, the nuts, *h'*, holding them permanently in place after once in position.

In order to apply spring-pressure to the yielding-roll I make use of a sliding-block, K, the tongue, *k*, of which enters and fits in the slots in the lateral bars, while the inner face of the wings, *k'*, rests upon the inner face of said bars and the seat, *k²*, fits against the ends of the axle and is confined against escape between the head thereof and the end of the roller. In the slot, *k³*, between the wings of the sliding-block rests the shouldered end, *l*, of a semi-elliptic spring, L, the shoulders, *l'*, of which hold these wings against the inner face of the corresponding lateral bar. A hand-screw, L', threaded through one of the cross-braces or transverse-bars at that side of the pair of wringing-rolls, passes loosely through the center of the spring and is headed thereover so that it revolves freely therein and the spring will be advanced or retracted as the screw is turned in the cross-bar, thereby increasing or decreasing the pressure upon the yielding roller.

The attachment when set into the pail will be secured therein by screws passing through the curved end-bars or bands.

In order to hold the pail firmly while the mop is being forcibly withdrawn from between the rolls, I apply foot-rests, M, at the bottom of the pail, each having a projecting

step, *m*, which rests upon the floor. One of these foot-rests will be applied at that side of the pail at which the mop is introduced and in line, or nearly so, with the axis of the movable roll, while the other rest will be applied near the end of the transverse diameter of the pail on the same side as this movable roller.

With this construction it is evident that the mop will be introduced into the pail through the open space between the side of the pail and the two inseting arms of the wringer-frame and will be passed between the ends of those arms into the space between the rolls, wedging the movable roll away from the fixed roll until fully introduced and then will be drawn out between these rolls in the usual manner, the pail being held firmly by the pressure of the feet upon the foot rests.

I claim—

1. The wringer-frame cast in one piece, composed of the curved end-bars or bands described on the internal radius of the pail, the short lateral bar uniting them at one side, the two inseting arms or bars at the other side and the braces or cross-bars extending from these inseting arms to the opposite side or lateral bar.

2. The combination, with the wringer-frame having curved end-bars described on the internal radius of the pail, the short lateral bar uniting the end-bars at one side, the inseting arms from said end-bars at the other side, and the bracing cross-bars leading to said inseting arms from the opposite side, or lateral bar, of the stationary roller mounted in the side-bar and one of the inseting arms, the yielding roller mounted in slots in the side-bar and the other inseting-arm, the spring pressing upon the sliding-boxes of the yielding roller, and the adjustment screw mounted in the corresponding brace or cross-bar.

3. The combination, with the wringer-frame as described, of the stationary roller, the movable roller and its headed axle, the sliding-blocks formed with wings to rest on the inner faces of the frame-bars, and with a tongue confined between the axle-head and the end of the roller, and the shouldered spring sitting into and against said wings to retain them in place.

BENJAMIN F. JONES.

Witnesses:

A. S. WELLS,
M. E. SHIELDS.