

June 20, 1961

H. BROSS

2,989,032

WRITING INSTRUMENT, PARTICULARLY OF THE BALL POINT TYPE

Filed March 8, 1956

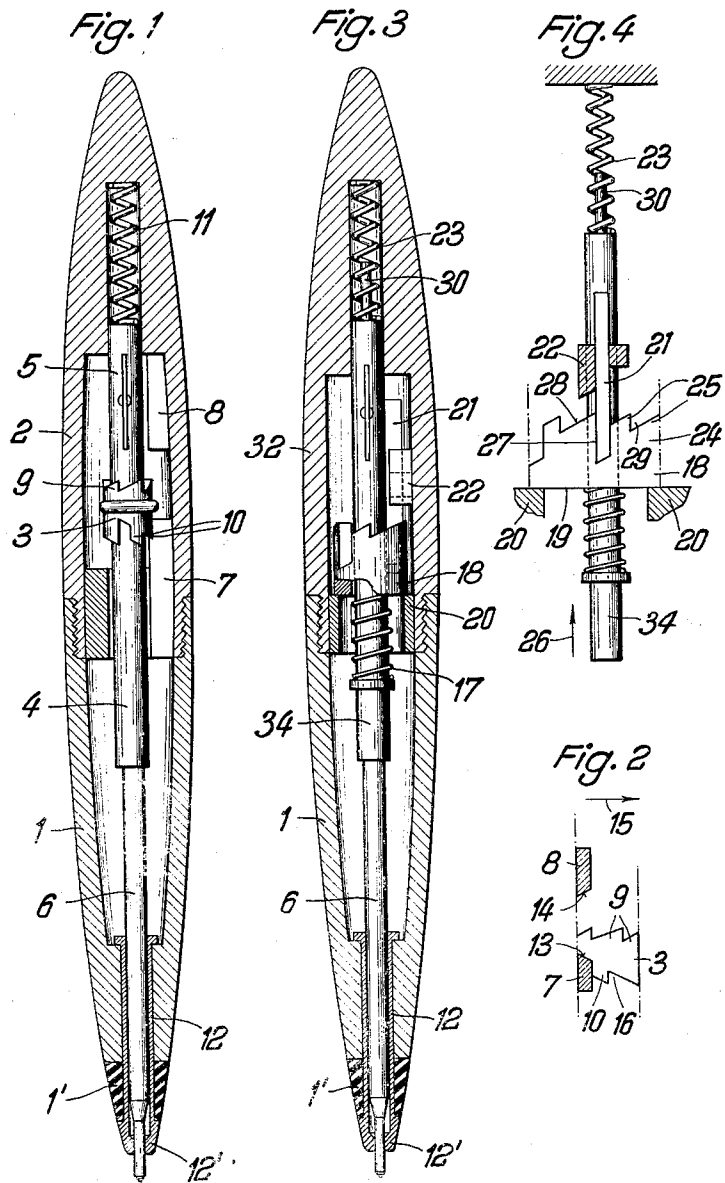

Inventor:
H. BROSS
By *Glasgow, Downing & Reebolt*
Attys.

1

2,989,032

WRITING INSTRUMENT, PARTICULARLY OF THE BALL POINT TYPE

Helmut Bross, Braunschweig, Germany, assignor, by mesne assignments, to Frank T. Johann, Berkeley Heights, N.J.

Filed Mar. 8, 1956, Ser. No. 570,330

Claims priority, application Germany Mar. 25, 1955

12 Claims. (Cl. 120—42.03)

The present invention relates to a writing instrument having a slidable writing means carrier, particularly a ball point type refill, which is under the influence of a spring force resisting the writing pressure, which writing instrument, by urging the entire stem or casing thereof against a suitable support, may be brought into an operative position in which the writing point of said carrier or refill is advanced for use, and which writing instrument may be brought back into an inoperative position by again using the entire stem thereof to urge the said writing point against the said support. The operation of the mechanism of known writing instruments of this type is a function of pressure, and proper operation requires a certain amount of skill on the part of the user, rendering malfunctioning unavoidable.

It is one object of the present invention to provide improvements in a writing instrument of the type indicated as regards both its construction and its operation. An essential feature of the writing instrument of the present invention resides in the provision of a positively operating indexing or shifting and locking mechanism comprising suitable means, such as rigid stops, which serve to limit the operative stroke length required for withdrawing and advancing, respectively, the said writing means carrier. Since the length of the said operative stroke substantially corresponds to the largest possible distance traveled by the respective part or parts, the operation of the writing instrument is extremely simple and requires no particular skill on the part of the user.

According to still another feature of the invention, even the movement of the writing means may be limited by a fixed stop.

Furthermore, the invention is concerned with other details of the design of the casing or stem as well as the locking mechanism.

Other objects, features and advantages of the present invention will be readily apparent from the following detailed description of a preferred embodiment thereof taken in conjunction with the accompanying drawings, in which:

FIG. 1 is a longitudinal sectional view, partly in elevation, of the ball point pen of the invention, of which the pressure-exerting tubular member has fixedly attached thereto a toothed sleeve member;

FIG. 2 is a development of the advancing and withdrawing mechanism used in the embodiment of FIG. 1;

FIG. 3 is a longitudinal view, partly in section, of a modified embodiment in which a pressure-exerting tubular member carries a sleeve member provided with teeth on one end only and both slidable and rotatable relative to said tubular member; and

FIG. 4 is a schematic representation, partly developed into the drawing plane, of the withdrawing and locking mechanism provided in the embodiment of FIG. 3.

Referring now more in particular to the drawings, in FIG. 1 the reference numeral 1 indicates the front portion and 2 the rear portion of a rigid two-piece stem or sleeve of a ball point writing utensil. A style actuating or pressure-exerting member 4 of tubular shape carries between its ends a fixed shifting sleeve 3 and, near one of its ends, a clamping means 5 which serves to grip an

2

elongate cylindrical writing style or ball point pen refill 6 inserted into the pressure-exerting tubular member. Provided on the inside of the rigid stem or casing 1, 2 are two rail-like projections or pawls 7 and 8, each of which cooperates with one of the toothed end faces of the ratchet element or shifting sleeve 3. On its rear end the said shifting sleeve carries a plurality of ratchet teeth or sawteeth 9 of uniform depth, and provided on the front end face of said sleeve are projections, the number of which is half that of the said sawteeth, the end faces of the said projections each carrying two sawteeth 10. The pressure-exerting tubular member 4 is subjected to the action of a compression spring 11 adapted to withstand the writing pressure. The front portion of the stem or casing 1, 2 carries a compressible member 1' the external contour of which merges into the curved or cambered contour of the entire writing utensil; disposed interiorly of said compressible member 1' is a centrally apertured point or slidable supporting tube 12 which, while preventing the compressible member from being distorted by bending, forms a hard point 12'.

With the ball point refill 6 in the writing position shown in FIG. 1, the actuator or pressure-exerting tubular member 4, which is acted upon by the spring 11, rests with a longer interspace 13 (FIG. 2) between the projections 10 against the fixed shifting rail 7. Upon the writing point of the writing utensil being urged against a support, the ball pen refill, together with the pressure-exerting tubular member and its shifting sleeve, is urged inwardly until one of the teeth 9 strikes the upper shifting rail 8. The inclination 14 of the rail 8 cooperating with the slanting faces of the teeth 9 produces a rotation of the shifting sleeve 3, together with the tubular member 4, this rotation, according to the depth of the teeth, amounting to one-half tooth spacing and occurring in the direction of the arrow 15 in FIG. 2. When the tubular member, upon the operating pressure being removed, is again advanced by the spring 11, the shifting rail 7, while producing a further rotation by one-half tooth space, engages in the space 16 between the two sawteeth 10. This locked position corresponds to the withdrawn position of the tubular member and the ball pen refill. Upon a further operation by urging the writing point against a support, causing also the point members 1', 12 and 12' to be urged inwardly by a small amount, the shifting operations will occur in a similar manner, causing the space 13 of the shifting sleeve 3 again to assume a position above the shifting rail 7. This position corresponds to the writing position in which the various parts are again in the positions indicated in FIGS. 1 and 2. Also during this operation, the shifting rail 8 constitutes the fixed stop limiting the motion of the ball pen refill.

Shown in FIGS. 3 and 4 is a ball point pen incorporating a modified form of back pressure and locking mechanism in which the tubular member will not be rotated and which affords greater dependability in operation. Slidably and rotatably supported on the tubular member 34 is a shifting sleeve 18 which is provided with teeth on its rear end face, and which is urged rearwardly by a compression spring 17 disposed between the said shifting sleeve and a collar formed on the tubular member. Associated with the flat front end face 19 of the shifting sleeve is a stop 20 carried by the inner wall of the casing of the writing utensil. The toothed rear end face of the shifting sleeve cooperates with a shifting rail 21 projecting from the tubular member and with another shifting rail 22 provided on the inside of the said casing 32. The tubular member 34 is slidably mounted but is held against rotation, and it is acted upon by a compression spring 23 the force of which is greater than that of the spring 17. The movable shifting sleeve has formed on its rear end a

plurality of projections 24, the end faces of each projection carrying two rearwardly oriented sawteeth 25. The beveled rails 21 and 22 are arranged in close proximity to one another.

In the illustrated position of the various parts, the tubular member 34 is in a position in which the ball point refill 6 is in its advanced writing position. When the tubular member 34 is moved in the direction of arrow 26 in FIG. 4 by urging the ball pen refill located therein in the same direction, the shifting sleeve 18 is retained by the rail 22 provided on the inside of the casing member 32, whereas the tubular member 34 carrying the rail 21 continues to move inwardly. Upon the rail 21 emerging from the long slot 27 of the shifting sleeve, the latter is released in the direction of rotation and is rotated by one-half shifting space by the beveled surfaces 28, causing the rail 21 of the tubular member 4 to move into the space 29 between the two sawteeth 25, the rail 21, by way of the shifting sleeve 18, resting against the stop 20 in a position which corresponds to the withdrawn position of the ball pen refill. Upon the mechanism being operated again, the various parts thereof will again assume their original positions shown in FIG. 3. The withdrawing and operating mechanism just described also constitutes a single-step mechanism in which the operating stroke may always be of the same magnitude, being selectively limited by a fixed limiting stop. The said limiting stop may, for example, be provided in the form of a pin-shaped extension 30 of the tubular member, which extension, when in its operative position, engages the inner end face of the rear end of the casing member 32. It will be appreciated that the length of stroke may also be limited by the extent to which the compressible member 1' of the front section 1 of the casing can be compressed, in which case the said pin-shaped extension 30 may be dispensed with.

It will be understood that modifications and variations may be effected without departing from the spirit and scope of the novel concepts of the present invention.

I claim:

1. A writing instrument comprising: a tubular casing defining first and second ends; a centrally apertured point having an outer end projecting beyond a first end of said casing and having its inner end slidably mounted in said casing for movement from a relatively extended position to a relatively retracted position with reference to said casing; first resilient means normally biasing said point to its relatively extended position; an elongate cylindrical writing style defining a writing tip and a base end and slidably mounted within said tubular casing between an extended position with its writing tip end slidably projected through said centrally apertured point and a retracted position with said end telescoped within said point; a style actuating member mounted longitudinally slidably in said casing in engagement with the base end of said style; second resilient means bearing against said actuating member biasing said member and said style to its extended position, said point, actuating member, and style being retractable together in said casing against the combined forces of said first and second resilient means under influence of axial retractive thrust applied to said writing tip and point; a ratchet element mounted in said casing adjacent said actuating member and having first and second ratchet teeth of respectively shorter and longer root depths; a pawl element, one of said elements being mounted in fixed position in said casing and the other of said elements being carried by said actuating member, with said first and second teeth limiting the extent of slidable extended movement of said actuating member and style movable therewith following each succeeding release of retractive axial thrust, said pawl when engaged in the root of said first ratchet tooth being operable to retain said member and style movable therewith in their retracted positions, said pawl when engaged in the root of said second ratchet tooth being operable to

allow said member and style to move to their fully extended positions under influence of said second resilient means.

2. A writing instrument according to claim 1 which includes aligning means including said first and second ratchet teeth and second resilient means for alternately aligning said pawl for engagement within the respective root depths of said first and second ratchet teeth following each succeeding release of retractive axial thrust.

3. A writing instrument having a positively operating shifting and locking mechanism comprising: a tubular casing defining first and second ends; a centrally apertured point member having an outer end projecting beyond a first end of said casing and having its inner end slidably mounted in said casing for movement from a relatively extended position to a relatively retracted position with reference to said casing; first resilient means associated with said point member and normally biasing said point member to its relatively extended position; an elongate cylindrical writing style member defining a writing tip and slidably movable within said tubular casing between an extended position with its writing tip slidably projected through said centrally apertured point member and a retracted position with said tip telescoped within said point member; an actuator in engagement with one of said members for conjoint movement therewith; second resilient means associated with said style member biasing said style member to an extended position, said point member, actuator and style member being retractable together in said casing against the combined forces of said first and second resilient means under influence of axial retractive thrust applied to said writing tip and point member; a ratchet unit in said casing adjacent said actuator and having first and second ratchet teeth of respectively shorter and longer root depths; and a pawl unit; one of said units being held by said actuator and the other of said units being held by said casing whereby said ratchet unit and said pawl unit are longitudinally movable relative to one another upon the application and release of retractive axial thrust, said pawl unit when within the root of said first ratchet tooth being operable to retain said actuator and member movable therewith in their retracted positions, said pawl unit when within the root of said second ratchet tooth being operable to allow said actuator and member movable therewith to move to their fully extended positions under influence of the resilient means associated with said movable member.

4. A writing instrument according to claim 3, wherein said actuator is carried by said style member.

5. A writing instrument according to claim 4, wherein said pawl unit is held by said actuator, said ratchet unit is defined by a sleeve encircling said actuator, a third resilient means within said casing engaging said sleeve and urging it into normal engagement with said pawl unit and a stop fixed to said casing and engageable with said ratchet unit, said stop being so positioned to permit the disengagement and relative longitudinal movement of said pawl unit and said ratchet unit upon the application of said axial retractive thrust.

6. A writing instrument according to claim 4, wherein said pawl unit is held by said casing, said ratchet unit is held by said actuator, and wherein said ratchet teeth are in circumferentially spaced relationship to each other.

7. A writing instrument according to claim 4, which includes aligning means for alternately aligning said pawl unit for engagement within the respective root depths of said first and second ratchet teeth following each succeeding release of retractive axial thrust, said aligning means including said first and second ratchet teeth and said second resilient means.

8. A writing instrument having a positively operating shifting and locking mechanism comprising: a tubular casing defining first and second ends; a centrally apertured point member carried by said casing having an outer end projecting beyond a first end of said casing, the

5

outer end of said point member being movable between a relatively extended position and a relatively retracted position with reference to said casing; an elongate cylindrical writing style member defining a writing tip and mounted within said tubular casing for slidable movement between an extended position with its writing tip slidably projected through said centrally apertured point member and a retracted position with said tip telescoped within said point member; resilient means within said casing adapted to engage said style member to bias said style member to an extended position; said point member and style member being retractable together in said casing against the force of said resilient means under influence of axial retractive thrust applied to said writing tip and point member; a ratchet unit in said casing defining first and second ratchet teeth of respectively shorter and longer root depths; and a pawl unit; one of said units being carried by said casing and the other of said units being carried by said style member whereby said ratchet unit and said pawl unit are longitudinally movable relative one another upon the application and release of retractive axial thrust, said pawl unit when within the root of said first ratchet tooth being operable to retain said style member in its retracted position, said pawl unit when within the root of said second ratchet tooth being operable to allow said style member to move to its fully extended position under influence of the resilient means associated with said style member.

9. A writing instrument according to claim 8, wherein said first and second ratchet teeth define a first set of ratchet teeth, a second set of ratchet teeth defined by said ratchet unit, said second set of teeth being in spaced and opposed relationship to said first set of ratchet teeth, said pawl unit being alternately engageable with said second and first set of ratchet teeth upon the application and release of said retractive axial thrust to direct said pawl unit into engagement within the root of said first ratchet tooth, said pawl unit being alternately engageable with said second and first set of ratchet teeth upon a succeeding application and release of said retractive axial thrust to direct said pawl unit into engagement within the root of said second ratchet tooth.

10. A writing instrument having a positively operating shifting and locking mechanism, comprising: a tubular casing defining first and second ends; a centrally apertured point member having an outer end projecting beyond a first end of said casing and having its inner end slidably mounted in said casing for movement from a relatively extended position to a relatively retracted posi-

6

tion with reference to said casing; first resilient means associated with said point member and normally biasing said point member to its relatively extended position; an elongate cylindrical writing style member defining a writing tip and slidably movable within said tubular casing between an extended position with its writing tip slidably projected through said centrally apertured point member and a retracted position with said tip telescoped within said point member; an actuator in engagement with one of said members and longitudinally movable therewith; second resilient means associated with said style member biasing said style member to an extended position; said point member, actuator and style member being retractable together in said casing against the combined forces of said first and second resilient means under influence of axial retractive thrust applied to said writing tip and point member; a sleeve unit in said casing adjacent said actuator and having first and second teeth defining first and second abutments, respectively, said abutments being longitudinally spaced relative to one another; and a pawl unit; one of said units being carried by said actuator and the other of said units being carried by said casing whereby said sleeve unit and said pawl unit are longitudinally movable relative to one another upon the application and release of retractive axial thrust, said pawl unit when engaging said first abutment being operable to retain said actuator and member movable therewith in their retracted positions, said pawl unit when engaging said second abutment being operable to allow said actuator and member movable therewith to move to their fully extended positions under influence of the resilient means associated with said movable member.

11. A writing instrument according to claim 10, wherein said actuator is carried on said style member, wherein said sleeve unit is carried by said actuator and wherein said pawl unit is carried by said casing.

12. A writing instrument according to claim 10, wherein said actuator is carried by said style member and wherein said sleeve unit is fixed to said casing.

References Cited in the file of this patent

FOREIGN PATENTS

80,470	Germany	Apr. 2, 1895
88,655	Germany	Nov. 26, 1895
706,734	France	Mar. 31, 1931
178,251	Switzerland	Feb. 17, 1936
635,144	Great Britain	Apr. 5, 1950